

the lumbar load transducer or its structural replacement to the pelvis weldment (drawing 210-4510) as shown in Figure P5 of this subpart.

(ii) Position the matching end of the rigid pelvis attachment fixture around the lumbar spine and align it over the four bolt holes.

(iii) Secure the fixture to the dummy with the four ¼-20×¾" bolts and attach the fixture to the table. Tighten the mountings so that the pelvis-lumbar joining surface is horizontal within ±1 deg and the buttocks and upper legs of the seated dummy are in contact with the test surface.

(iv) Attach the loading adapter bracket to the upper part of the torso as shown in Figure P5 of this subpart and zip up the torso jacket.

(v) Point the upper arms vertically downward and the lower arms forward.

(3)(i) Flex the thorax forward three times from vertical until the torso reference plane reaches 30 ±2 degrees from vertical. The torso reference plane, as shown in figure P5 of this subpart, is defined by the transverse plane tangent to the posterior surface of the upper backplate of the spine box weldment (drawing 210-8020).

(ii) Remove all externally applied flexion forces and support the upper torso half in a vertical orientation for 30 minutes to prevent it from drooping.

(4) Remove the external support and after two minutes measure the initial orientation angle of the upper torso reference plane of the seated, unsupported dummy as shown in Figure P5 of this subpart. The initial orientation of the torso reference plane may not exceed 15 degrees.

(5) Attach the pull cable at the point of load application on the adaptor bracket while maintaining the initial torso orientation. Apply a pulling force in the midsagittal plane, as shown in Figure P5 of this subpart, at any upper torso flexion rate between 0.5 and 1.5 degrees per second, until the torso reference plane reaches 45 ±0.5 degrees of flexion relative to the vertical transverse plane.

(6) Continue to apply a force sufficient to maintain 45 ±0.5 degrees of flexion for 10 seconds, and record the highest applied force during the 10-second period.

(7) [Reserved]

(8) Release all force at the loading adaptor bracket as rapidly as possible and measure the return angle with respect to the initial angle reference plane as defined in paragraph (c)(4) of this section 3 to 4 minutes after the release.

**§ 572.146 Test conditions and instrumentation.**

(a) The test probe for thoracic impacts, except for attachments, shall be of rigid metallic construction and concentric about its longitudinal axis. Any attachments to the impactor such as suspension hardware, and impact vanes, must meet the requirements of § 572.144(c)(7) of this part. The impactor shall have a mass of 1.70 ±0.02 kg (3.75 ±0.05 lb) and a minimum mass moment of inertia 164 kg-cm<sup>2</sup> (0.145 lb-in-sec<sup>2</sup>) in yaw and pitch about the CG of the probe. One-third (1/3) of the weight of suspension cables and any attachments to the impact probe must be included in the calculation of mass, and such components may not exceed five percent of the total weight of the test probe. The impacting end of the probe, perpendicular to and concentric with the longitudinal axis of the probe, has a flat, continuous, and non-deformable 50.8 ±0.25 mm (2.00 ±0.01 inch) diameter face with an edge radius of 7.6/12.7 mm (0.3/0.5 in). The impactor shall have a 53.3 mm (2.1 in) dia. cylindrical surface extending for a minimum of 25.4 mm (1.0 in) to the rear from the impact face. The probe's end opposite to the impact face has provisions for mounting an accelerometer with its sensitive axis collinear with the longitudinal axis of the probe. The impact probe has a free air resonant frequency not less than 1000 Hz limited to the direction of the longitudinal axis of the impactor.

(b) Head accelerometers shall have the dimensions, response characteristics, and sensitive mass locations specified in drawing SA 572-S4 and be mounted in the head as shown in drawing 210-0000.

(c) The neck force-moment transducer shall have the dimensions, response characteristics, and sensitive axis locations specified in drawing SA 572-S19 and be mounted at the upper neck transducer location as shown in

**§ 572.146**

**49 CFR Ch. V (10–1–04 Edition)**

drawing 210-0000. A lower neck transducer as specified in drawing SA 572-S19 is allowed to be mounted as optional instrumentation in place of part No. ATD6204, as shown in drawing 210-0000.

(d) The shoulder force transducers shall have the dimensions and response characteristics specified in drawing SA 572-S21 and be allowed to be mounted as optional instrumentation in place of part No. 210-3800 in the torso assembly as shown in drawing 210-0000.

(e) The thorax accelerometers shall have the dimensions, response characteristics, and sensitive mass locations specified in drawing SA 572-S4 and be mounted in the torso assembly in triaxial configuration at the T4 location, as shown in drawing 210-0000. Triaxial accelerometers may be mounted as optional instrumentation at T1, and T12, and in uniaxial configuration on the sternum at the midpoint level of ribs No. 1 and No. 3 and on the spine coinciding with the midpoint level of No. 3 rib, as shown in drawing 210-0000. If used, the accelerometers must conform to SA-572-S4.

(f) The chest deflection potentiometer shall have the dimensions and response characteristics specified in drawing SA-572-S50 and be mounted in the torso assembly as shown drawing 210-0000.

(g) The lumbar spine force/moment transducer may be mounted in the torso assembly as shown in drawing 210-0000 as optional instrumentation in place of part No. 210-4150. If used, the transducer shall have the dimensions and response characteristics specified in drawing SA-572-S20.

(h) The pubic force transducer may be mounted in the torso assembly as shown in drawing 210-0000 as optional instrumentation in place of part No. 921-0022-036. If used, the transducer shall have the dimensions and response characteristics specified in drawing SA-572-S18.

(i) The acetabulum force transducers may be mounted in the torso assembly as shown in drawing 210-0000 as optional instrumentation in place of part No. 210-4522. If used, the transducer shall have the dimensions and response characteristics specified in drawing SA-572-S22.

(j) The anterior-superior iliac spine transducers may be mounted in the torso assembly as shown in drawing 210-0000 as optional instrumentation in place of part No. 210-4540-1, -2. If used, the transducers shall have the dimensions and response characteristics specified in drawing SA-572-S17.

(k) The pelvis accelerometers may be mounted in the pelvis in triaxial configuration as shown in drawing 210-0000 as optional instrumentation. If used, the accelerometers shall have the dimensions and response characteristics specified in drawing SA-572-S4.

(l) The outputs of acceleration and force-sensing devices installed in the dummy and in the test apparatus specified by this part shall be recorded in individual data channels that conform to the requirements of SAE Recommended Practice J211/1, Rev. Mar 95 "Instrumentation for Impact Tests—Part 1-Electronic Instrumentation" (refer to § 572.140(a)(3)), with channel classes as follows:

- (1) Head acceleration—Class 1000
- (2) Neck
  - (i) Force—Class 1000
  - (ii) Moments—Class 600
  - (iii) Pendulum acceleration—Class 180
  - (iv) Rotation potentiometer response (if used)—CFC 60.
- (3) Thorax:
  - (i) Rib/sternum acceleration—Class 1000
  - (ii) Spine and pendulum accelerations—Class 180
  - (iii) Sternum deflection—Class 600
  - (iv) Shoulder force—Class 180
- (4) Lumbar:
  - (i) Forces—Class 1000
  - (ii) Moments—Class 600
  - (iii) Torso flexion pulling force—Class 60 if data channel is used
- (5) Pelvis
  - (i) Accelerations—Class 1000
  - (ii) Acetabulum, pubic symphysis—Class 1000,
  - (iii) Iliac wing forces—Class 180
  - (m) Coordinate signs for instrumentation polarity shall conform to the Sign Convention For Vehicle Crash Testing, Surface Vehicle Information Report, SAE J1733, 1994-12 (refer to § 572.140(a)(4)).
- (n) The mountings for sensing devices shall have no resonance frequency less

**Nat'l Highway Traffic Safety Admin., DOT**

**§ 572.146**

than 3 times the frequency range of the applicable channel class.

(o) Limb joints shall be set at 1G, barely restraining the weight of the limbs when they are extended horizontally. The force required to move a limb segment shall not exceed 2G throughout the range of limb motion.

(p) Performance tests of the same component, segment, assembly, or

fully assembled dummy shall be separated in time by a period of not less than 30 minutes unless otherwise noted.

(q) Surfaces of dummy components are not painted except as specified in this part or in drawings subtended by this part.

FIGURES TO SUBPART P OF PART 572

Figure P1  
HEAD DROP TEST SET-UP SPECIFICATIONS

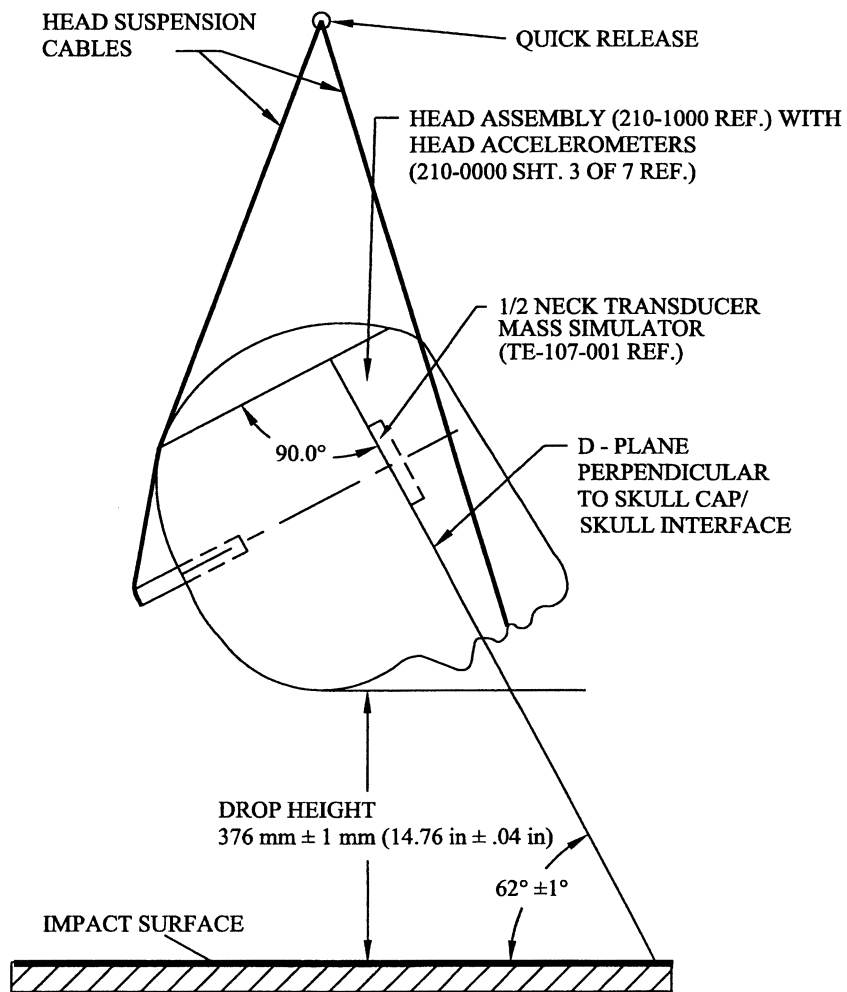
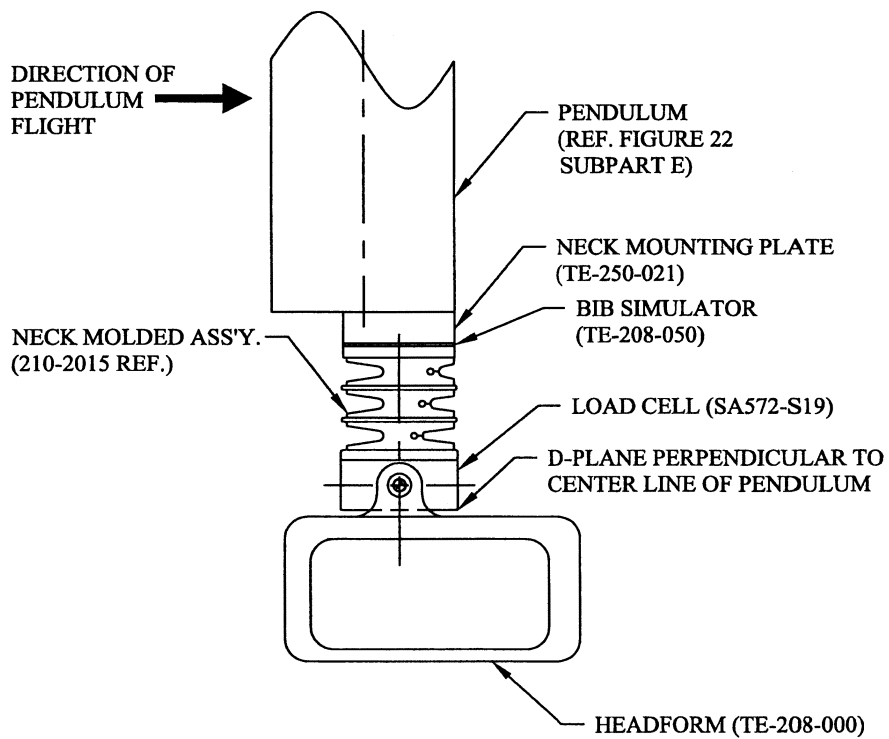
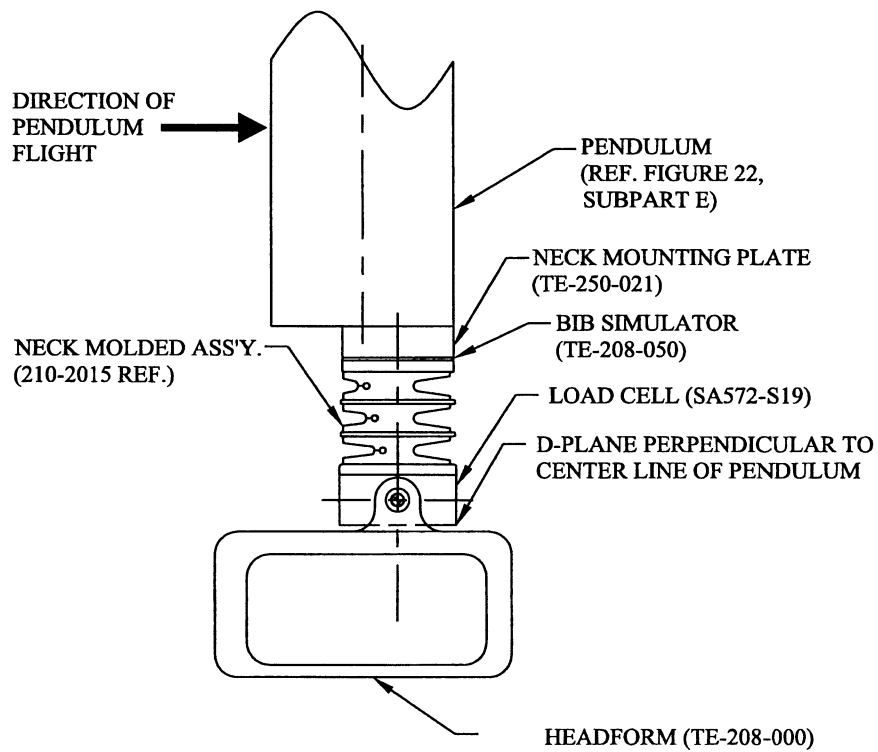

Figure P2  
NECK FLEXION TEST SET-UP SPECIFICATIONS



NOTE: MOUNT NECK AT LEADING EDGE OF PENDULUM TO AVOID INTERFERENCE WITH HEADFORM MOTION. PENDULUM SHOWN IN VERTICAL ORIENTATION.

Figure P3  
NECK EXTENSION TEST SET-UP SPECIFICATIONS



NOTE: MOUNT NECK AT LEADING EDGE OF PENDULUM TO AVOID  
INTERFERENCE WITH HEADFORM MOTION.  
PENDULUM SHOWN IN VERTICAL ORIENTATION.

Figure P4

**THORAX IMPACT TEST SET-UP SPECIFICATIONS**

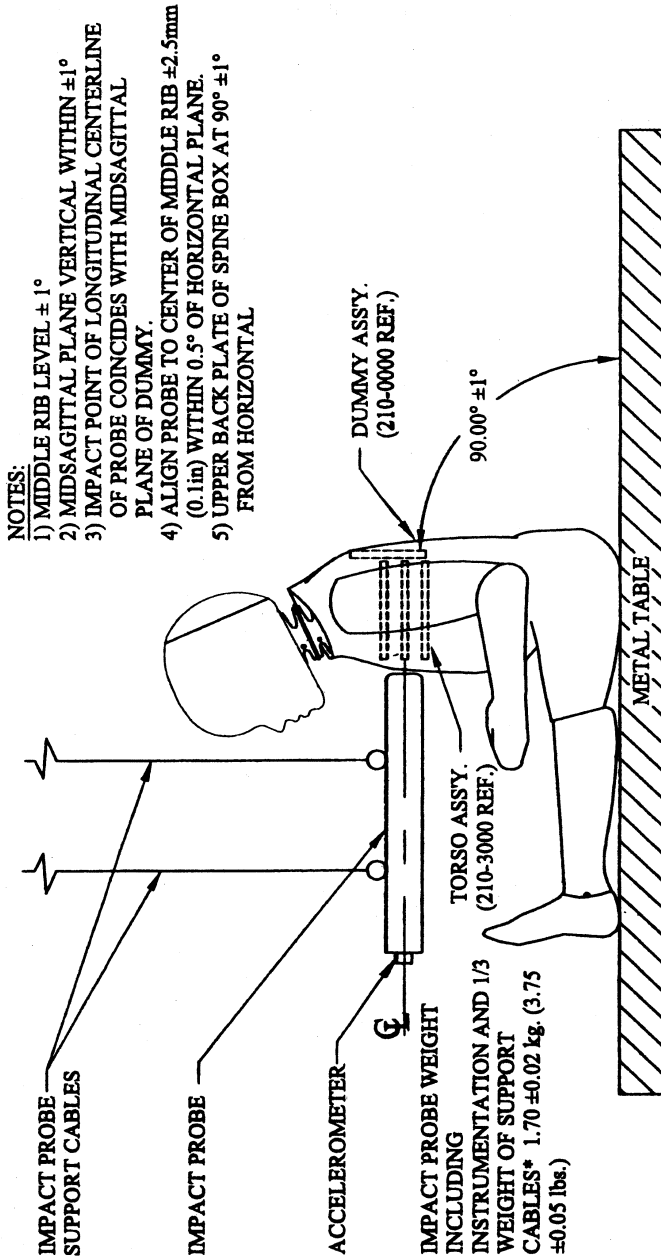

**NOTES:**

- 1) MIDDLE RIB LEVEL  $\pm 1^\circ$
- 2) MIDSAGITTAL PLANE VERTICAL WITHIN  $\pm 1^\circ$
- 3) IMPACT POINT OF LONGITUDINAL CENTERLINE OF PROBE COINCIDES WITH MIDSAGITTAL PLANE OF DUMMY.
- 4) ALIGN PROBE TO CENTER OF MIDDLE RIB  $\pm 2.5\text{mm}$  (0.1in) WITHIN  $0.5^\circ$  OF HORIZONTAL PLANE.
- 5) UPPER BACK PLATE OF SPINE BOX AT  $90^\circ \pm 1^\circ$  FROM HORIZONTAL

\* 1/3 WEIGHT OF PROBE SUPPORT CABLES AND THEIR ATTACHMENTS TO THE IMPACT PROBE NOT TO EXCEED 5% OF THE TOTAL IMPACT PROBE WEIGHT.

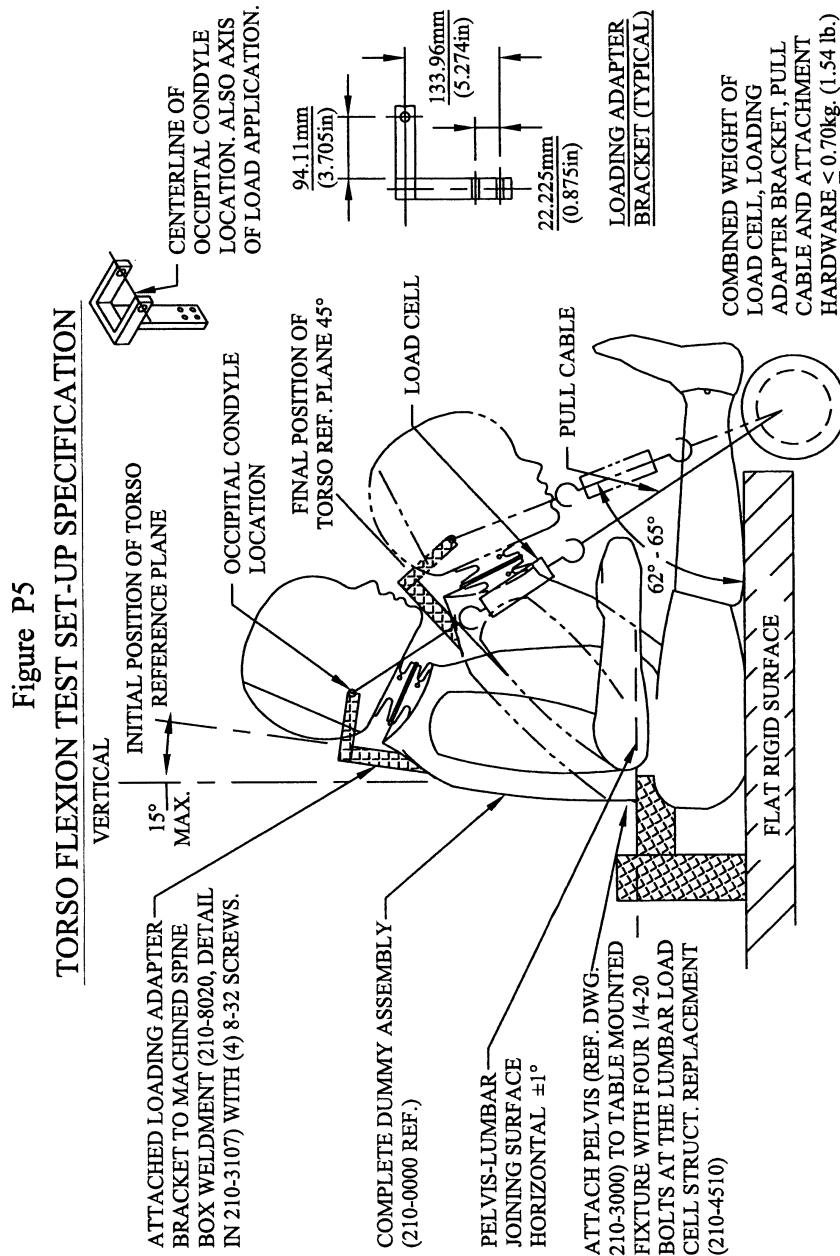

[65 FR 15262, Mar. 22, 2000, as amended at 66 FR 64376, Dec. 13, 2001]