

TABLE II - STOPPING DISTANCES

Vehicle Test Speed (miles per hour)	Stopping Distance in feet for tests indicated															
	I-1st (preburnished) & 4th effectiveness; spike effectiveness check				II-2d effectiveness				III-3d (lightly loaded vehicles) effectiveness				IV-Inoperative brake power and power assist unit; partial failure			
	(a)	(b)	(c)	(d)	(a)	(b) & (c)	(d)	(e)	(a)	(b)	(c)	(d)	(e)	(a)	(b) & (c)	(d) & (e)
30.....	'57	'65	'469 (1st) '465 (4th and spike) '72	88	'54	'57	78	'70	51	57	65	84	70	114	130	170
35.....	74	83	91	132	70	74	106	96	67	74	83	114	96	155	176	225
40.....	96	108	119	173	91	96	138	124	87	96	108	149	124	202	229	288
45.....	121	137	150	218	115	121	175	158	110	121	137	189	158	257	291	358
50.....	150	169	185	264	142	150	216	195	135	150	169	233	195	317	359	435
55.....	181	204	224	326	172	181	261	236	163	181	204	281	236	383	433	530
60.....	'216	'242	'267	388	'204	'216	'310	'280	'194	'216	'242	'335	'280	'456	'517	'613
80.....	'405	'459	'510	NA	'383	NA	NA	NA	NA	NA	NA	NA	NA	NA	NA	NA
95.....	'607	NA	NA	NA	NA	NA	NA	NA	NA	NA	NA	NA	NA	NA	NA	NA
100.....	'673	NA	NA	NA	NA	NA	NA	NA	NA	NA	NA	NA	NA	NA	NA	NA

¹ Distance for specified tests. ² Applicable to school buses only. NA=Not applicable
 Note: (a) Passenger cars; (b) vehicles other than passenger cars with GVWR of less than 8,000 lbs; (c) Vehicles with GVWR of not less than 8,000 lbs and not more than 10,000 lbs; (d) vehicles, other than buses, with GVWR greater than 10,000 lbs; (e) buses, including school buses, with GVWR greater than 10,000 lbs.

TABLE III—INOPERATIVE BRAKE POWER ASSIST AND BRAKE POWER UNITS

Stop No.	Average deceleration, FPSPS				Equivalent stopping distance, feet			
	Column 1—brake power assist		Column 2—brake power unit		Column 3—brake power assist		Column 4—brake power unit	
	(a)	(b) and (c)	(a)	(b) and (c)	(a)	(b) and (c)	(a)	(b) and (c)
1	16.0	14.0	16.0	13.0	242	277	242	298
2	12.0	12.0	13.0	11.0	323	323	298	352
3	10.0	10.0	12.0	10.0	388	388	323	388
4	9.0	8.5	11.0	9.5	431	456	352	409
5	8.0	7.5	10.0	9.0	484	517	388	431
6	7.5	6.7	9.5	8.5	517	580	409	456
7	¹ 7.0	¹ 6.0	9.0	8.0	554	646	431	484
8	NA	NA	8.5	7.5	NA	NA	456	517
9	NA	NA	8.0	7.0	NA	NA	484	554
10	NA	NA	7.5	6.5	NA	NA	517	596
11	NA	NA	¹ 7.0	¹ 6.0	NA	NA	554	646

¹ Depleted. (a) Passenger cars; (b) vehicles other than passenger cars with GVWR of 10,000 lbs or less; (c) vehicles with GVWR greater than 10,000 lbs; NA=Not applicable.

[41 FR 29696, July 19, 1976]

EDITORIAL NOTE: For FEDERAL REGISTER citations affecting § 571.106 see the List of CFR Sections Affected which appears in the Finding Aids section of the printed volume and on GPO Access.

§ 571.106 Standard No. 106; Brake hoses.

S1. *Scope.* This standard specifies labeling and performance requirements for motor vehicle brake hose, brake hose assemblies, and brake hose end fittings.

S2. *Purpose.* The purpose of this standard is to reduce deaths and injuries occurring as a result of brake system failure from pressure or vacuum loss due to hose or hose assembly rupture.

S3. *Application.* This standard applies to passenger cars, multipurpose passenger vehicles, trucks, buses, trailers, and motorcycles, and to hydraulic, air, and vacuum brake hose, brake hose assemblies, and brake hose end fittings for use in those vehicles.

S4. *Definitions.*
A armor means protective material installed on a brake hose to increase the resistance of the hose or hose assembly to abrasion or impact damage.

Brake hose means a flexible conduit, other than a vacuum tubing connector,

manufactured for use in a brake system to transmit or contain the fluid pressure or vacuum used to apply force to a vehicle's brakes. For hose, a dimensional description such as "¼-inch hose" refers to the nominal inside diameter. For tubing, a dimensional description such as "¼-in tubing" refers to the nominal outside diameter.

Brake hose assembly means a brake hose, with or without armor, equipped with end fittings for use in a brake system, but does not include an air or vacuum assembly prepared by the owner or operator of a used vehicle, by his employee, or by a repair facility, for installation in that used vehicle.

Brake hose end fitting means a coupler, other than a clamp, designed for attachment to the end of a brake hose.

Free length means the linear measurement of hose exposed between the end fittings of a hose assembly in a straight position.

Permanently attached end fitting means an end fitting that is attached by deformation of the fitting about the hose by crimping or swaging, or an end fitting that is attached by use of a sacrificial sleeve or ferrule that requires replacement each time a hose assembly is rebuilt.

Preformed means a brake hose that is manufactured with permanent bends and is shaped to fit a specific vehicle without further bending.

Rupture means any failure that results in separation of a brake hose from its end fitting or in leakage.

Vacuum tubing connector means a flexible conduit of vacuum that (i) connects metal tubing to metal tubing in a brake system, (ii) is attached without end fittings, and (iii) when installed, has an unsupported length less than the total length of those portions that cover the metal tubing.

S5. *Requirements—hydraulic brake hose, brake hose assemblies, and brake hose end fittings.*

S5.1 *Construction.* (a) Each hydraulic brake hose assembly shall have permanently attached brake hose end fittings which are attached by deformation of the fitting about the hose by crimping or swaging.

(b) Each hydraulic brake hose assembly that is equipped with a permanent supplemental support integrally at-

tached to the assembly and is manufactured as a replacement for use on a vehicle not equipped, as an integral part of the vehicle's original design, with a means of attaching the support to the vehicle shall be equipped with a bracket that is integrally attached to the supplemental support and that adapts the vehicle to properly accept this type of brake hose assembly.

S5.2 *Labeling.*

S5.2.1 Each hydraulic brake hose, except hose sold as part of a motor vehicle, shall have at least two clearly identifiable stripes of at least one-sixteenth of an inch in width, placed on opposite sides of the brake hose parallel to its longitudinal axis. One stripe may be interrupted by the information required by S5.2.2, and the other stripe may be interrupted by additional information at the manufacturer's option. However, hydraulic brake hose manufactured for use only in an assembly whose end fittings prevent its installation in a twisted orientation in either side of the vehicle, need not meet the requirements of S5.2.1.

S5.2.2 Each hydraulic brake hose shall be labeled, or cut from bulk hose that is labeled, at intervals of not more than 6 inches, measured from the end of one legend to the beginning of the next, in block capital letters and numerals at least one-eighth of an inch high, with the information listed in paragraphs (a) through (e) of this section. The information need not be present on hose that is sold as part of a brake hose assembly or a motor vehicle.

(a) The symbol DOT, constituting a certification by the hose manufacturer that the hose conforms to all applicable motor vehicle safety standards.

(b) A designation that identifies the manufacturer of the hose, which shall be filed in writing with: Office of Vehicle Safety Compliance, Equipment Division NVS-222, National Highway Traffic Safety Administration, 400 Seventh St. SW., Washington, DC 20590. The marking may consist of a designation other than block capital letters required by S5.2.2.

(c) The month, day, and year, or the month and year, of manufacture, expressed in numerals. For example, 10/1/96 means October 1, 1996.

(d) The nominal inside diameter of the hose expressed in inches or fractions of inches, or in millimeters followed by the abbreviation "mm."

(e) Either "HR" to indicate that the hose is regular expansion hydraulic hose or "HL" to indicate that the hose is low expansion hydraulic hose.

S5.2.3 *Package labeling for brake hose assemblies designed to be used with a supplemental support.* (a) Each hydraulic brake hose assembly that is equipped with a permanent supplemental support integrally attached to the assembly and is manufactured as a replacement assembly for a vehicle equipped, as an integral part of the vehicle's original design, with a means of attaching the support to the vehicle shall be sold in a package that is marked or labeled as follows: "FOR USE ON [insert *Manufacturer, Model Name*] ONLY";

(b) Each hydraulic brake hose assembly that is equipped with a permanent supplemental support integrally attached to the assembly and is manufactured as a replacement for use on a vehicle not equipped, as an integral part of the vehicle's original design, with a means of attaching the support to the vehicle shall comply with paragraphs (a) (1) and (2) of this section:

(1) Be sold in a package that is marked or labeled as follows: "FOR USE ONLY WITH A SUPPLEMENTAL SUPPORT."

(2) Be accompanied by clear, detailed instructions explaining the proper installation of the brake hose and the supplemental support bracket to the vehicle and the consequences of not attaching the supplemental support bracket to the vehicle. The instructions shall be printed on or included in the package specified in paragraph (a)(1) of this section.

S5.2.4 Each hydraulic brake hose assembly, except those sold as part of a motor vehicle, shall be labeled by means of a band around the brake hose assembly as specified in this paragraph or, at the option of the manufacturer, by means of labeling as specified in S5.2.4.1. The band may at the manufacturer's option be attached so as to move freely along the length of the assembly, as long as it is retained by the end fittings. The band shall be etched,

embossed, or stamped in block capital letters, numerals or symbols at least one-eighth of an inch high, with the following information:

(a) The symbol DOT constituting certification by the hose assembler that the hose assembly conforms to all applicable motor vehicle safety standards.

(b) A designation that identifies the manufacturer of the hose assembly, which shall be filed in writing with: Office of Vehicle Safety Compliance, Equipment Division NVS-222, National Highway Traffic Safety Administration, 400 Seventh St. SW., Washington, DC 20590. The designation may consist of block capital letters, numerals or a symbol.

S5.2.4.1 At least one end fitting of a hydraulic brake hose assembly shall be etched, stamped or embossed with a designation at least one-sixteenth of an inch high that identifies the manufacturer of the hose assembly and is filed in accordance with S5.2.4(b).

S5.3 *Test requirements.* A hydraulic brake hose assembly or appropriate part thereof shall be capable of meeting any of the requirements set forth under this heading, when tested under the conditions of S13 and the applicable procedures of S6. However, a particular hose assembly or appropriate part thereof need not meet further requirements after having been subjected to and having met the constriction requirement (S5.3.1) and any one of the requirements specified in S5.3.2 through S5.3.13.

S5.3.1 *Constriction.* Except for that part of an end fitting which does not contain hose, every inside diameter of any section of a hydraulic brake hose assembly shall be not less than 64 percent of the nominal inside diameter of the brake hose (S6.12).

S5.3.2 *Expansion and burst strength.* The maximum expansion of a hydraulic brake hose assembly at 1,000 psi, 1,500 psi and 2,900 psi shall not exceed the values specified in Table I (S6.1), except that a brake hose larger than $\frac{3}{16}$ inch or 5 mm is not subject to the 2,900 psi expansion test requirements. The hydraulic brake hose assembly shall then withstand water pressure of 4,000 psi for 2 minutes without rupture, and then shall not rupture at less than 7,000

psi for a 1/8 inch, 3 mm, or smaller diameter hose, or at less than 5,000 psi for a hose with a diameter larger than 1/8 inch or 3 mm (S6.2).

TABLE I—MAXIMUM EXPANSION OF FREE LENGTH BRAKE HOSE, CC/FT

Hydraulic brake hose, inside diameter	Test pressure					
	1,000 psi		1,500 psi		2,900 psi	
	Regular expansion hose	Low expansion hose	Low expansion hose	Regular expansion hose	Regular expansion hose	Low expansion hose
1/8 inch, or 3mm, or less	0.66	0.33	0.79	0.42	1.21	0.61
> 1/8 inch or 3mm, to 3/16 inch or 5 mm	0.86	0.55	1.02	0.72	1.67	0.91
> 3/16 inch or 5 mm	1.04	0.82	1.30	1.17	*	*

S5.3.3 *Whip resistance.* A hydraulic brake hose assembly shall not rupture when run continuously on a flexing machine for 35 hours (S6.3).

S5.3.4 *Tensile strength.* A hydraulic brake hose assembly shall withstand a pull of 325 pounds without separation of the hose from its end fittings during a slow pull test, and shall withstand a pull of 370 pounds without separation of the hose from its end fittings during a fast pull test (S6.4).

S5.3.5 *Water absorption and burst strength.* A hydraulic brake hose assembly, after immersion in water for 70 hours (S6.5), shall withstand water pressure of 4,000 psi for 2 minutes, and then shall not rupture at less than 5,000 psi (S6.2).

S5.3.6 *Water absorption and tensile strength.* A hydraulic brake hose assembly, after immersion in water for 70 hours (S6.5), shall withstand a pull of 325 pounds without separation of the hose from its end fittings during a slow pull test, and shall withstand a pull of 370 pounds without separation of the hose from its end fittings during a fast pull test (S6.4).

S5.3.7 *Water absorption and whip resistance.* A hydraulic brake hose assembly, after immersion in water for 70 hours (S6.5), shall not rupture when run continuously on a flexing machine for 35 hours (S6.3).

S5.3.8 *Low-temperature resistance.* A hydraulic brake hose conditioned at a temperature between minus 49 degrees Fahrenheit (minus 45 degrees Celsius) and minus 54 degrees Fahrenheit (minus 48 degrees Celsius) for 70 hours shall not show cracks visible without magnification when bent around a cylinder as specified in S6.6 (S6.6).

S5.3.9 *Brake fluid compatibility, constriction, and burst strength.* Except for brake hose assemblies designed for use with mineral or petroleum-based brake fluids, a hydraulic brake hose assembly shall meet the constriction requirement of S5.3.1 after having been subjected to a temperature of 248 degrees Fahrenheit (120 degrees Celsius) for 70 hours while filled with SAE RM-66-04 “Compatibility Fluid,” as described in appendix B of SAE Standard J1703, revised JAN 1995, “Motor Vehicle Brake Fluid.” This incorporation by reference was approved by the Director of the Federal Register in accordance with 5 U.S.C. 552(a) and 1 CFR part 51. Copies may be obtained from the Society of Automotive Engineers, Inc., 400 Commonwealth Drive, Warrendale, PA 15096-0001. Copies may be inspected at the National Highway Traffic Safety Administration, Technical Information Services, 400 Seventh Street, SW., Plaza Level, Room 403, Washington, DC 20590, or at the National Archives and Records Administration (NARA). For information on the availability of this material at NARA, call 202-741-6030, or go to: http://www.archives.gov/federal_register/code_of_federal_regulations/ibr_locations.html. It shall then withstand water pressure of 4,000 psi for 2 minutes and thereafter shall not rupture at less than 5,000 psi (S6.2 except all sizes of hose are tested at 5,000 psi).

S5.3.10 *Ozone resistance.* A hydraulic brake hose shall not show cracks visible under 7-power magnification after exposure to ozone for 70 hours at 104 °F. (S6.8).

S5.3.12 *High temperature impulse test.* A brake hose assembly tested under the conditions in S6.10:

(a) Shall withstand pressure cycling for 150 cycles, at 295 degrees Fahrenheit (146 degrees Celsius) without leakage;

(b) Shall not rupture during a 2-minute, 4,000 psi pressure hold test, and;

(c) Shall not burst at a pressure less than 5,000 psi.

S5.3.13 *End fitting corrosion resistance.* After 24 hours of exposure to salt spray, a hydraulic brake hose end fitting shall show no base metal corrosion on the end fitting surface except where crimping or the application of labeling information has caused displacement of the protective coating (S6.11).

S6. *Test procedures—Hydraulic brake hose, brake hose assemblies, and brake hose end fittings.*

S6.1. *Expansion test.*

S6.1.1 *Apparatus.* Utilize a test apparatus (as shown in Figure 1) which consists of:

- (a) Source for required fluid pressure;
- (b) Test fluid of water without any additives and free of gases;
- (c) Reservoir for test fluid;
- (d) Pressure gauges;
- (e) Brake hose end fittings in which to mount the hose vertically; and
- (f) Graduate burette with 0.05 cc increments.

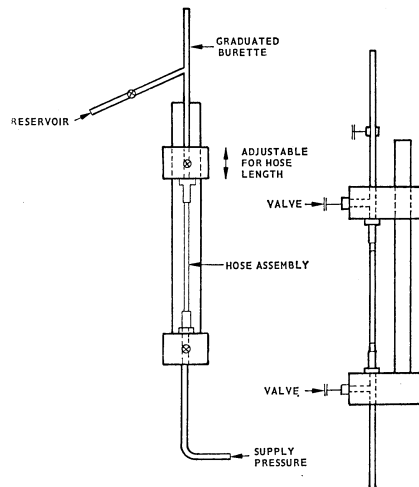

FIG. 1—EXPANSION TEST APPARATUS

S6.1.2 *Preparation.* (a) Measure the free length of the hose assembly.

(b) Mount the hose so that it is in a vertical straight position without tension when pressure is applied.

(c) Fill the hose with test fluid and bleed all gases from the system.

(d) Close the valve to the burette and apply 1,500 psi for 10 seconds; then release pressure.

S6.1.3 *Calculation of expansion at 1,000 and 1,500 psi.* (a) Adjust the fluid level in the burette to zero.

(b) Close the valve to the burette, apply pressure at the rate of 15,000 psi per minute, and seal 1,000 psi in the hose (1,500 psi in the second series, and 2,900 psi in the third series).

(c) After 3 seconds open the valve to the burette for 10 seconds and allow the fluid in the expanded hose to rise into the burette.

(d) Repeat the procedure in steps (b) and (c) twice. Measure the amount of test fluid which has accumulated in the burette as a result of the three applications of pressure.

(e) Calculate the volumetric expansion per foot by dividing the total accumulated test fluid by 3 and further dividing by the free length of the hose in feet.

S6.2 *Burst strength test.* (a) Connect the brake hose to a pressure system

and fill it completely with water, allowing all gases to escape.

(b) Apply water pressure of 4,000 psi at a rate of 15,000 psi per minute.

(c) After 2 minutes at 4,000 psi, increase the pressure at the rate of 15,000 psi per minute until the pressure exceeds 5,000 psi for a brake hose larger than 1/8 inch or 3 mm diameter, or until the pressure exceeds 7,000 psi for a brake hose of 1/8 inch, 3 mm, or smaller diameter.

S6.3 *Whip resistance test.*

S6.3.1 *Apparatus.* Utilize test apparatus that is dynamically balanced and includes:

(a) A movable header consisting of a horizontal bar equipped with capped end fittings and mounted through bearings at each end to points 4 inches from the center of two vertically rotating disks whose edges are in the same vertical plane;

(b) An adjustable stationary header parallel to the movable header in the same horizontal plane as the centers of the disks, and fitted with open end fittings;

(c) An elapsed time indicator; and

(d) A source of water pressure connected to the open end fittings.

S6.3.2 *Preparation.* (a) Except for the supplemental support specified in S6.3.2(d), remove all external appendages including, but not limited to, hose armor, chafing collars, mounting brackets, date band and spring guards.

(b) Measure the hose free length.

(c) Mount the hose in the whip test machine, introducing slack as specified in Table II for the size hose tested, measuring the projected length parallel to the axis of the rotating disks. The manufacturer may, at his option, adapt the fitting attachment points to permit mounting hose assemblies equipped with angled or other special fittings in the same orientation as hose assemblies equipped with straight fittings.

(d) In the case of a brake hose assembly equipped with a permanent supplemental support integrally attached to the assembly, the assembly may be mounted using the supplemental support and associated means of simulating its attachment to the vehicle. Mount the supplemental support in the same vertical and horizontal planes as

the stationary header end of the whip test fixture described in S6.3.1(b). Mount or attach the supplemental support so that it is positioned in accordance with the recommendation of the assembly manufacturer for attaching the supplemental support on a vehicle.

TABLE II—HOSE LENGTHS

Free length between end fittings, inches	Slack, inches	
	1/8 inch or 3 mm hose or less	More than 1/8 inch or 3 mm hose
8 to 15½, inclusive	1.750
10 to 15½, inclusive	1,000
Over 15½ to 19 inclusive	1.250
Over 19 to 24, inclusive	0.750

S6.3.3 *Operation.* (a) Apply 235 psi water pressure and bleed all gases from the system.

(b) Drive the movable head at 800 rpm.

S6.4 *Tensile strength test.* Utilize a tension testing machine conforming to the requirements of American Society for Testing and Materials (ASTM) E4-03, “Standard Practices for Force Verification of Testing Machines,” and provided with a recording device to measure the force applied. This incorporation by reference was approved by the Director of the Federal Register in accordance with 5 U.S.C. 552(a) and 1 CFR part 51. Copies may be obtained from the American Society for Testing and Materials (ASTM) International, 100 Barr Harbor Drive, P.O. Box C700, West Conshohocken, PA 19428-2959. Copies may be inspected at the National Highway Traffic Safety Administration, Technical Information Services, 400 Seventh St., S.W., Plaza Level, Room 403, Washington, D.C. 20590, or at the National Archives and Records Administration (NARA). For information on the availability of this material at NARA, call 202-741-6030, or go to: http://www.archives.gov/federal_register/code_of_federal_regulations/ibr_locations.html.

S6.4.1 *Preparation.* Mount the hose assembly to ensure straight, evenly distributed machine pull.

S6.4.2 *Operation.* (a) Conduct the slow pull test by applying tension at a rate of 1 inch per minute travel of the moving head until separation occurs.

(b) Conduct the fast pull test by applying tension at a rate of 2 inches per minute travel of the moving head until separation occurs.

S6.5 Water absorption sequence tests.

(a) Prepare three brake hose assemblies and measure the free length of the hose assemblies.

(b) Immerse the brake hose assemblies in distilled water at 185 degrees Fahrenheit (85 degrees Celsius) for 70 hours. Remove the brake hose assemblies from the water and condition in air at room temperature for 30 minutes.

(c) Conduct the tests in S6.2, S6.3, and S6.4, using a different hose for each sequence.

S6.6 Low temperature resistance test.

S6.6.1 Preparation. (a) Remove hose armor, if any, and condition the hose in a straight position in air at a temperature between minus 49 degrees Fahrenheit and minus 54 degrees Fahrenheit (minus 45 degrees Celsius and minus 48 degrees Celsius) for 70 hours.

(b) Condition a cylinder in air at a temperature between minus 49 degrees Fahrenheit and minus 54 degrees Fahrenheit (minus 45 degrees Celsius and minus 48 degrees Celsius) for 70 hours, using a cylinder of 2½ inches in diameter for tests of hose less than ½ inch or 3mm, 3 inches in diameter for tests of ½ inch or 3 mm hose, 3½ inches in diameter for tests of ¾ to 1 inch hose or 4 mm to 6 mm hose, and 4 inches in diameter for tests of hose greater than ¾ inch or 6 mm in diameter.

S6.6.2 Flexibility testing. Bend the conditioned hose 180 degrees around the conditioned cylinder at a steady rate in a period of 3 to 5 seconds. Examine without magnification for cracks.

S6.7 Brake fluid compatibility test.

S6.7.1 Preparation. (a) Attach a hose assembly below a 1-pint reservoir filled with 100 ml. of SAE RM-66-04 Compatibility Fluid as shown in Figure 2. (SAE RM-66-03 Compatibility Fluid, as described in appendix A of SAE Standard J1703 NOV83, "Motor Vehicle Brake Fluid," November 1983, may be used in place of SAE RM-66-04 until January 1, 1995.)

(b) Fill the hose assembly with brake fluid, seal the lower end, and place the

test assembly in an oven in a vertical position.

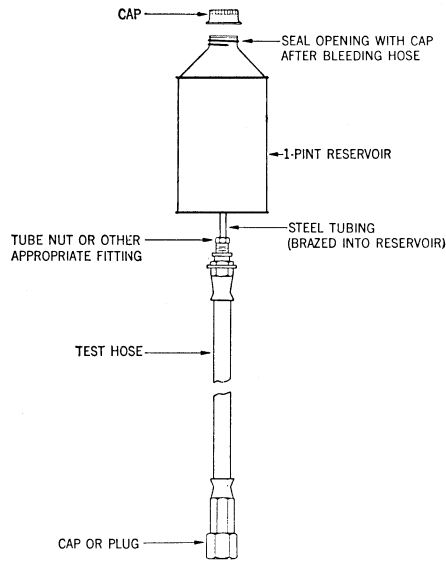

FIG. 2. BRAKE FLUID COMPATIBILITY APPARATUS

S6.7.2 Oven treatment. (a) Condition the hose assembly at 200 °F. for 70 hours.

(b) Cool the hose assembly at room temperature for 30 minutes.

(c) Drain the brake hose assembly, immediately determine that every inside diameter of any section of the hose assembly, except for that part of an end fitting which does not contain hose, is not less than 64 percent of the nominal inside diameter of the hose, and conduct the test specified in S6.2.

S6.8 Ozone resistance test. Utilize a cylinder with a diameter eight times the nominal outside diameter of the brake hose excluding armor.

S6.8.1 Preparation. After removing any armor, bind a hydraulic brake hose 360° around the cylinder. In the case of hose shorter than the circumference of the cylinder, bend the hose so that as much of its length as possible is in contact.

S6.8.2 Exposure to ozone. (a) Condition the hose on the cylinder in air at room temperature for 24 hours.

(b) Immediately thereafter, condition the hose on the cylinder for 70 hours in

§571.106

49 CFR Ch. V (10-1-10 Edition)

an exposure chamber having an ambient air temperature of 104 degrees Fahrenheit (40 degrees Celsius) during the test and containing air mixed with ozone in the proportion of 100 parts of ozone per 100 million parts of air by volume.

(c) Examine the hose for cracks under 7-power magnification, ignoring areas immediately adjacent to or within the area covered by binding.

S6.9 *End fitting corrosion resistance test.* Utilize the apparatus described in ASTM B117-64, "Salt Spray (Fog) Testing".

S6.9 *Dynamic ozone test.*

S6.9.1 *Apparatus.* Utilize a test apparatus shown in Figure 3 which is constructed so that:

(a) It has a fixed pin with a vertical orientation over which one end of the brake hose is installed.

(b) It has a movable pin that is oriented 30 degrees from vertical, with the top of the movable pin angled towards the fixed pin. The moveable pin maintains its orientation to the fixed pin throughout its travel in the horizontal plane. The other end of the brake hose is installed on the movable pin.

Figure 3. Dynamic Ozone Test Apparatus

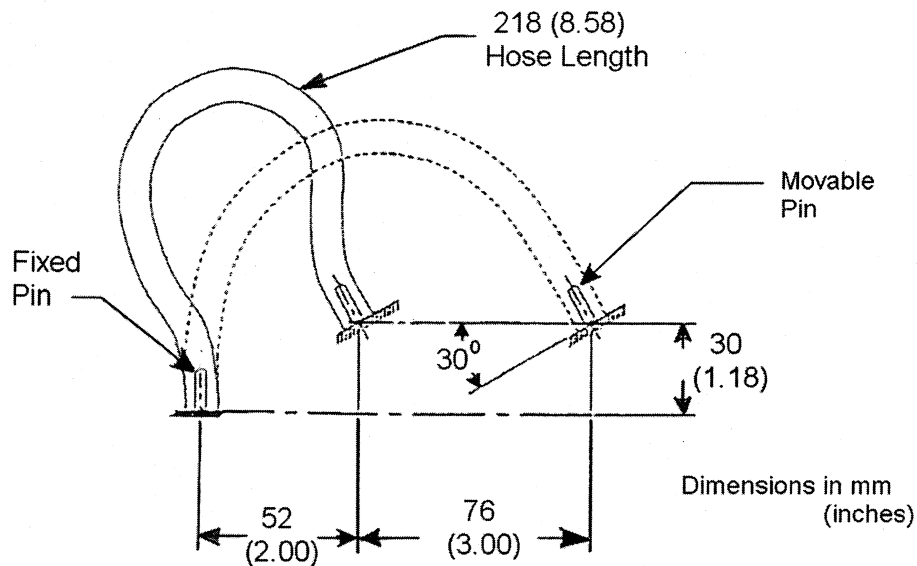

S6.9.2 *Preparation.* (a) Precondition the hose assembly by laying it on a flat surface in an unstressed condition, at room temperature, for 24 hours.

(b) Cut the brake hose assembly to a length of 8.6 inches (218 mm), such that no end fittings remain on the cut hose.

(c) Mount the brake hose onto the test fixture by fully inserting the fixture pins into each end of the hose. Secure the hose to the fixture pins using a band clamp at each end of the hose.

(d) Place the test fixture into an ozone chamber

(e) Stabilize the atmosphere in the ozone chamber so that the ambient temperature is 104 °F (40 degrees Celsius) and the air mixture contains air mixed with ozone in the proportion of 100 parts of ozone per 100 million parts of air by volume. This atmosphere is to remain stable throughout the remainder of the test.

(f) Begin cycling the movable pin at a rate of 0.3 Hz. Continue the cycling for 48 hours.

(g) At the completion of 48 hours of cycling, remove the test fixture from the ozone chamber. Without removing the hose from the test fixture, visually examine the hose for cracks without magnification, ignoring areas immediately adjacent to or within the area covered by the band clamps. Examine the hose with the movable pin at any point along its travel.

S6.10 *High temperature impulse test.*

S6.10.1 *Apparatus.* (a) A pressure cycling machine to which one end of the brake hose assembly can be attached, with the entire hose assembly installed vertically inside of a circulating air oven. The machine shall be capable of increasing the pressure in the hose from zero psi to 1600 psi, and decreasing the pressure in the hose from 1600 psi to zero psi, within 2 seconds.

(b) A circulating air oven that can reach a temperature of 295 degrees Fahrenheit (146 degrees Celsius) within 30 minutes, and that can maintain a constant 295 degrees F (146 degrees Celsius) thereafter, with the brake hose assembly inside of the oven and attached to the pressure cycling machine.

(c) A burst test apparatus to conduct testing specified in S6.2

S6.10.2 *Preparation.* (a) Connect one end of the hose assembly to the pressure cycling machine and plug the other end of the hose. Fill the pressure cycling machine and hose assembly with SAE RM-66-04 "Compatibility Fluid," as described in appendix B of SAE Standard J1703, revised JAN 1995

"Motor Vehicle Brake Fluid," and bleed all gases from the system.

(b) Place the brake hose assembly inside of the circulating air oven in a vertical position. Increase the oven temperature to 295 degrees F (146 degrees Celsius) and maintain this temperature throughout the pressure cycling test.

(c) During each pressure cycle, the pressure in the hose is increased from zero psi to 1600 psi and held constant for 1 minute, then the pressure is decreased from 1600 psi to zero psi and held constant for 1 minute. Perform 150 pressure cycles on the brake hose assembly.

(d) Remove the brake hose assembly from the oven, disconnect it from the pressure cycling machine, and drain the fluid from the hose. Cool the brake hose assembly at room temperature for 45 minutes.

(e) Wipe the brake hose using acetone to remove residual Compatibility Fluid. Conduct the burst strength test in S6.2, except all sizes of hose are tested at 5,000 psi.

S6.11 *End fitting corrosion test.* Utilize the apparatus described in ASTM B117-03, "Standard Practice for Operating Salt Spray (Fog) Apparatus". This incorporation by reference was approved by the Director of the Federal Register in accordance with 5 U.S.C. 552(a) and 1 CFR Part 51. Copies may be obtained from the American Society for Testing and Materials (ASTM) International, 100 Barr Harbor Drive, P.O. Box C700, West Conshohocken, PA 19428-2959. Copies may be inspected at the National Highway Traffic Safety Administration, Technical Information Services, 400 Seventh St., SW., Plaza Level, Room 403, Washington, DC 20590, or at the National Archives and Records Administration (NARA). For information on the availability of this material at NARA, call (202) 741-6030, or go to: http://www.archives.gov/federal_register/code_of_federal_regulations/ibr_locations.html.

S6.11.1 *Construction.* Construct the salt spray chamber so that:

(a) The construction material does not affect the corrosiveness of the fog.

(b) The hose assembly is supported or suspended 30 degrees from the vertical

and parallel to the principal direction of the horizontal flow of fog through the chamber.

(c) The hose assembly does not contact any metallic material or any material capable of acting as a wick

(d) Condensation which falls from the assembly does not return to the solution reservoir for respraying.

(e) Condensation from any source does not fall on the brake hose assemblies or the solution collectors.

(f) Spray from the nozzles is not directed onto the hose assembly.

S6.11.2 *Preparation.* (a) Plug each end of the hose assembly.

(b) Mix a salt solution five parts by weight of sodium chloride to 95 parts of distilled water, using sodium chloride substantially free of nickel and copper, and containing on a dry basis not more than 0.1 percent of sodium iodide and not more than 0.3 percent total impurities. Ensure that the solution is free of suspended solids before the solution is atomized.

(c) After atomization at 95 degrees Fahrenheit (35 degrees Celsius), ensure that the collected solution is in the PH range of 6.5 to 7.2. Make the PH measurements at 77 degrees Fahrenheit (28 degrees Celsius).

(d) Maintain a compressed air supply to the nozzle or nozzles free of oil and dirt and between 10 and 25 psi.

S6.11.3 *Operation.* Subject the brake hose assembly to the salt spray continuously for 24 hours.

(a) Regulate the mixture so that each collector will collect from 1 to 2 milliliters of solution per hour for each 80 square centimeters of horizontal collecting area.

(b) Maintain exposure zone temperature at 95 degrees Fahrenheit (35 degrees Celsius).

(c) Upon completion, remove the salt deposit from the surface of the hose by washing gently or dipping in clean running water not warmer than 100 degrees Fahrenheit (38 degrees Celsius) and then drying immediately.

S6.12 *Constriction test.* Brake hose constriction test requirements shall be met using at least one of the methods specified in S6.12.1, S6.12.2, or S6.12.3.

S6.12.1 *Plug gauge.* (a) Utilize a plug gauge as shown in Figure 4. Diameter "A" is equal to 64 percent of the nomi-

nal inside diameter of the hydraulic brake hose being tested.

(b) Brake hose assemblies that are to be used for additional testing have constriction testing only at each end fitting. Other brake hose assemblies may be cut into 3-inch lengths to permit constriction testing of the entire assembly. Hose assemblies with end fittings that do not permit entry of the gauge (*e.g.*, restrictive orifice or banjo fitting) are cut 3 inches from the point at which the hose terminates in the end fitting and then tested from the cut end.

(c) Hold the brake hose in a straight position and vertical orientation.

(d) Place the spherical end of the plug gauge just inside the hose or end fitting. If the spherical end will not enter the hose or end fitting using no more force than gravity acting on the plug gauge, this constitutes failure of the constriction test.

(e) Release the plug gauge. Within 3 seconds, the plug gauge shall fall under the force of gravity alone up to the handle of the gauge. If the plug gauge does not fully enter the hose up to the handle of the gauge within three seconds, this constitutes failure of the constriction test.

S6.12.2 *Extended plug gauge.* (a) The test in 6.12.1 may be conducted with an extended plug gauge to enable testing of the entire brake hose from one end fitting, without cutting the brake hose. The extended plug gauge weight and spherical diameter specifications are as shown in Figure 4, but the handle portion of the gauge may be deleted and the gauge length may be greater than 3 inches.

(b) The required performance of the extended plug gauge in S6.12.1(e) is that after the plug gauge is released, the extended plug gauge shall fall under the force of gravity alone at an average rate of 1 inch per second until the spherical diameter of the extended gauge passes through all portions of the brake hose assembly containing hose. If the extended plug gauge does not pass through all portions of the brake hose assembly containing hose at an average rate of 1 inch per second, this constitutes failure of the constriction test.

FIGURE 4. CONSTRICTION TEST PLUG GAUGE

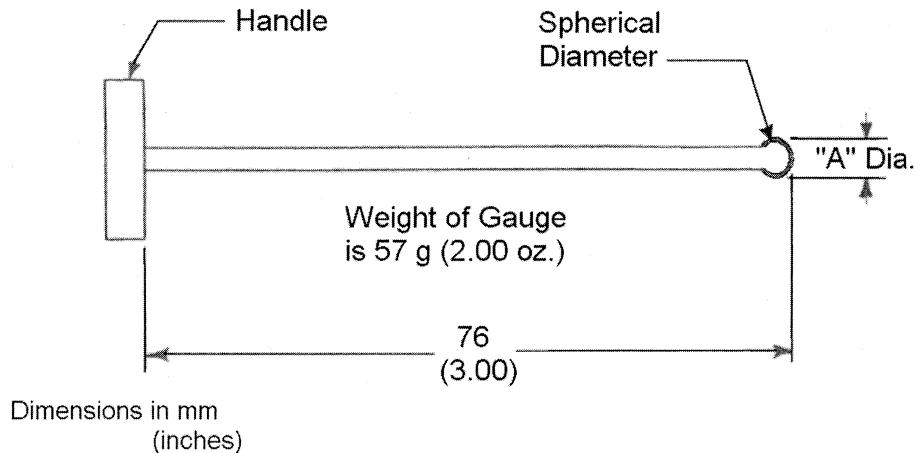

S6.12.3 *Drop ball test.* (a) Utilize a rigid spherical ball with a diameter equal to 64 percent of the nominal inside diameter of the hydraulic brake hose being tested. The weight of the spherical ball shall not exceed 2 ounces (57 grams).

(b) Hold the brake hose in a straight position and vertical orientation.

(c) Hold the ball just above the end fitting.

(d) Release the ball. The ball shall fall under the force of gravity alone completely through all portions of the brake hose assembly containing hose, at an average rate of 1 inch per second. Failure of the ball to pass completely through all portions of the brake hose assembly containing hose, at an average rate of 1 inch per second, constitutes failure of the constriction test.

S7. *Requirements—Air brake hose, brake hose assemblies, and brake hose end fittings.*

S7.1 *Construction.* Each air brake hose assembly shall be equipped with permanently attached brake hose end fittings or reusable brake hose end fittings. Each air brake hose constructed of synthetic or natural elastomeric rubber shall conform to the dimensional requirements specified in Table

III, except for brake hose manufactured in metric sizes.

S7.2 *Labeling*

S7.2.1 *Hose.* Each air brake hose shall be labeled, or cut from bulk hose that is labeled, at intervals of not more than 6 inches, measured from the end of one legend to the beginning of the next, in block capital letters and numerals at least one-eighth of an inch high, with the information listed in paragraphs (a) through (e) of this section. The information need not be present on hose that is sold as part of a brake hose assembly or a motor vehicle.

(a) The symbol DOT, constituting a certification by the hose manufacturer that the hose conforms to all applicable motor vehicle safety standards.

(b) A designation that identifies the manufacturer of the hose, which shall be filed in writing with: Office of Vehicle Safety Compliance, Equipment Division NVS-222, National Highway Traffic Safety Administration, 400 Seventh St. SW., Washington, DC 20590. The designation may consist of block capital letters, numerals, or a symbol.

§ 571.106

49 CFR Ch. V (10–1–10 Edition)

(c) The month, day, and year, or the month and year, of manufacture, expressed in numerals. For example, 10/1/96 means October 1, 1996.

(d) The nominal inside diameter of the hose expressed in inches or fractions of inches or in millimeters. The abbreviation “mm” shall follow hose sizes that are expressed in millimeters. (Examples: 3/8, 1/2 (1/2SP in the case of 1/2

inch special air brake hose), 4mm, 6mm.)

(e) The type designation corresponding to the brake hose dimensions in Table III. Type A shall be labeled with the letter “A”, Type AI shall be labeled with the letters “AI”, and type AII shall be labeled with the letters “AII”. Metric air brake hose shall be labeled with the letter “A.”

TABLE III—AIR BRAKE HOSE DIMENSIONS—INSIDE DIAMETER (ID) AND OUTSIDE DIAMETER (OD) DIMENSIONS IN INCHES (MILLIMETERS)

	Type AI ⁽²⁾ —Hose Size—Nominal Inside Diameter					
	3/16	1/4	5/16	13/32	1/2	5/8
Min. I.D.	0.227 (5.8)	0.289 (7.3)	0.352 (8.9)	0.407 (10.3)	0.469 (11.9)	0.594 (15.1)
Max. I.D.	0.273 (6.9)	0.335 (8.5)	0.398 (10.1)	0.469 (11.9)	0.531 (13.5)	0.656 (16.7)
Min. O.D.	0.594 (15.1)	0.656 (16.7)	0.719 (18.3)	0.781 (19.8)	0.844 (21.4)	1.031 (26.2)
Max. O.D.	0.656 (16.7)	0.719 (18.3)	0.781 (19.8)	0.843 (21.4)	0.906 (23.0)	1.094 (27.8)
	Type AII ⁽²⁾ —Hose Size—Nominal Inside Diameter					
	3/16	1/4	5/16	13/32	1/2	5/8
Min. I.D.	0.188 (4.8)	0.250 (6.4)	0.312 (7.9)	0.406 (10.3)	0.500 (12.7)	0.625 (15.9)
Max. I.D.	0.214 (5.4)	0.281 (7.1)	0.343 (8.7)	0.437 (11.1)	0.539 (13.7)	0.667 (16.9)
Min. O.D.	0.472 (12.0)	0.535 (13.6)	0.598 (15.1)	0.714 (18.1)	0.808 (20.5)	0.933 (23.7)
Max. O.D.	0.510 (13.0)	0.573 (14.6)	0.636 (16.2)	0.760 (19.3)	0.854 (21.7)	0.979 (24.9)
	Type AII ⁽²⁾ —Hose Size—Nominal Inside Diameter					
	3/16	1/4	5/16	13/32	1/2	5/8
Min. I.D.	0.188 (4.8)	0.250 (6.4)	0.312 (7.9)	0.406 (10.3)	0.500 (12.7)	0.625 (15.9)
Max. I.D.	0.214 (5.4)	0.281 (7.1)	0.343 (8.7)	0.437 (11.1)	0.539 (13.7)	0.667 (16.9)
Min. O.D.	0.500 (12.7)	0.562 (14.3)	0.656 (16.7)	0.742 (18.8)	0.898 (22.8)	1.054 (26.8)
Max. O.D.	0.539 (13.7)	0.602 (15.3)	0.695 (17.7)	0.789 (20.1)	0.945 (24.0)	1.101 (27.9)

⁽¹⁾Notes: Type A, sizes 3/8, 7/16, and 1/2 Special can be assembled with reusable end fittings. All sizes can be assembled using permanently-attached (crimped) end fittings.

⁽²⁾Types AI and AII, all sizes, can be assembled with reusable or permanently-attached (crimped) end fittings.

S7.2.2 *End fittings.* Except for an end fitting that is attached by deformation of the fitting about a hose by crimping or swaging, at least one component of each air brake hose fitting shall be etched, embossed, or stamped in block

capital letters and numerals at least one-sixteenth of an inch high with the following information:

(a) The symbol DOT, constituting a certification by the manufacturer of that component that the component

conforms to all applicable motor vehicle safety standards.

(b) A designation that identifies the manufacturer of that component of the fitting, which shall be filed in writing with: Office of Vehicle Safety Compliance, Equipment Division NVS-222, National Highway Traffic Safety Administration, 400 Seventh St. S.W., Washington, DC 20590. The designation may consist of block capital letters, numerals, or a symbol.

(c) The letter "A" shall indicate intended use in air brake systems. In the case of an end fitting intended for use in a reusable assembly with brake hose subject to Table III, "AI" or "AII" shall indicate use with Type I or Type II hose, respectively.

(d) The nominal inside diameter of the hose to which the fitting is properly attached expressed in inches or fractions of inches or in millimeters. (See examples in S7.2.1 (d).) The abbreviation "mm" shall follow hose sizes that are expressed in millimeters.

S7.2.3 *Assemblies.* Each air brake hose assembly made with end fittings that are attached by crimping or swaging, except those sold as part of a motor vehicle, shall be labeled by means of a band around the brake hose assembly as specified in this paragraph or, at the option of the manufacturer, by means of labeling as specified in S7.2.3.1. The band may at the manufacturer's option be attached so as to move freely along the length of the assembly, as long as it is retained by the end fittings. The band shall be etched, embossed, or stamped in block capital letters, numerals or symbols at least one-eighth of an inch high, with the following information:

(a) The symbol DOT, constituting certification by the hose assembler that the hose assembly conforms to all applicable motor vehicle safety standards.

(b) A designation that identifies the manufacturer of the hose assembly, which shall be filed in writing with: Office of Crash Avoidance Standards, Ve-

hicle Dynamics Division, National Highway Traffic Safety Administration, 400 Seventh Street SW., Washington, DC 20590. The designation may consist of block capital letters, numerals or a symbol.

S7.2.3.1 At least one end fitting of an air brake hose assembly made with end fittings that are attached by crimping or swaging shall be etched, stamped or embossed with a designation at least one-sixteenth of an inch high that identifies the manufacturer of the hose assembly and is filed in accordance with S7.2.3(b).

S7.3 *Test requirements.* Each air brake hose assembly or appropriate part thereof shall be capable of meeting any of the requirements set forth under this heading, when tested under the conditions of S13 and the applicable procedures of S8. However, a particular hose assembly or appropriate part thereof need not meet further requirements after having met the constriction requirement (S7.3.1) and then having been subjected to any one of the requirements specified in S7.3.2 through S7.3.13.

S7.3.1 *Constriction.* Every inside diameter of any section of an air brake hose assembly shall not be less than 66 percent of the nominal inside diameter of the brake hose. (S8.14)

S7.3.2 *High temperature resistance.* An air brake hose shall not show external or internal cracks, charring, or disintegration visible without magnification when straightened after being bent for 70 hours at 212 degrees Fahrenheit (100 degrees Celsius) over a small test cylinder having the radius specified in Table IV for the size of hose tested. (S8.1)

S7.3.3 *Low temperature resistance.* The inside and outside surfaces of an air brake hose shall not show cracks as a result of conditioning at minus 40 degrees Fahrenheit (minus 40 degrees Celsius) for 70 hours when bent around a large test cylinder having the radius specified in Table IV for the size of hose tested (S8.2).

TABLE IV—AIR BRAKE HOSE DIAMETERS AND TEST CYLINDER RADII

Nominal hose inside diameter, inches ¹	3/16	1/4	5/16	3/8	13/32	7/16, 1/2	5/8
---	------	-----	------	-----	-------	-----------	-----

TABLE IV—AIR BRAKE HOSE DIAMETERS AND TEST CYLINDER RADII—Continued

Nominal hose inside diameter, millimeters ¹	4, 5	6	8	10	12	16
Small test cylinder, radius in inches (millimeters) ²	1 (25)	1½ (38)	1¾ (45)	1¾ (45)	1⅞ (48)	2 (51)	2½ (64)
Large test cylinder, radius in inches (millimeters) ³	2 (51)	2½ (64)	3 (76)	3½ (89)	3½ (89)	4 (102)	4½ (114)

Notes:
¹These sizes are listed to provide test cylinder radii for brake hoses manufactured in these sizes. They do not represent conversions.
²Small test cylinders are used for the high temperature resistance test.
³Large test cylinders are used for the low temperature resistance, ozone resistance, and adhesion of wire-reinforced hose tests.

S7.3.4 *Oil resistance.* After immersion in ASTM No. 3 oil for 70 hours at 212 °F. the volume of a specimen prepared from the inner tube and cover of an air brake hose shall not increase more than 100 percent (S8.3).

S7.3.5 *Ozone resistance.* An air brake hose assembly shall not show cracks visible under 7-power magnification after exposure to ozone for 70 hours at 104 degrees Fahrenheit (40 degrees Celsius) when bent around a test cylinder of the radius specified in Table IV for the size of hose tested (S8.4).

S7.3.6 *Length change.* An air brake hose shall not contract in length more than 7 percent nor elongate more than 5 percent when subjected to air pressure of 200 psi (S8.5).

S7.3.7 *Adhesion.* (a) Except for hose reinforced by wire, an air brake hose shall withstand a tensile force of 8 pounds per inch of length before separation of adjacent layers (S8.6).

(b) An air brake hose reinforced by wire shall permit a steel ball to roll freely along the entire length of the inside of the hose when the hose is subjected to a vacuum of 25 inches of Hg and bent around a test cylinder (S8.13).

S7.3.8 *Flex strength and air pressure leakage.* An air brake hose assembly of the length specified in the table accompanying Figure 5, when subjected to a flex test and internal pressure cycling, shall be capable of having its internal pressure increased from zero to 140 psi within 2 minutes with pressurized air supplied through an orifice (S8.7).

S7.3.9 *Corrosion resistance and burst strength.* An air brake hose assembly exposed to salt spray shall not rupture when exposed to hydrostatic pressure of 900 psi (S8.8).

S7.3.10 *Tensile strength.* An air brake hose assembly designed for use between a frame and axle or between a towed and towing vehicle shall withstand, without separation of the hose from its end fittings, a pull of 250 pounds if it is ¼ inch, 6 mm, or less in nominal inside diameter, or a pull of 325 pounds if it is larger than ¼ inch or 6 mm in nominal inside diameter. An air brake hose assembly designed for use in any other application shall withstand, without separation of the hose from its end fittings, a pull of 50 pounds if it is ¼ inch, 6 mm, or less in nominal inside diameter, 150 pounds if it is larger than ¼ inch or 6 mm and equal to or smaller than ½ inch or 12 mm in nominal inside diameter, or 325 pounds if it is larger than ½ inch or 12 mm in nominal inside diameter (S8.9).

S7.3.11 *Water absorption and tensile strength.* After immersion in distilled water for 70 hours, an air brake hose assembly designed for use between a frame and axle or between a towed and a towing vehicle shall withstand, without separation of the hose from its end fittings, a pull of 250 pounds if it is ¼ inch or less or 6 mm or less in nominal inside diameter, or a pull of 325 pounds if it is larger than ¼ inch or 6 mm in nominal inside diameter. After immersion in distilled water for 70 hours, an air brake hose assembly designed for

use in any other application shall withstand, without separation of the hose from its end fittings, a pull of 50 pounds if it is ¼ inch or 6 mm or less in nominal inside diameter, 150 pounds if it is larger than ¼ inch or 6 mm and equal to or smaller than ½ inch or 12 mm in nominal inside diameter, or 325 pounds if it is larger than ½ inch or 12 mm in nominal inside diameter. (S8.10)

S7.3.12 *Zinc chloride resistance.* The outer cover of an air brake hose shall not show cracks visible under 7-power magnification after immersion in a 50 percent zinc chloride aqueous solution for 200 hours (S8.11).

S7.3.13 *End fitting corrosion resistance.* After 24 hours of exposure to salt spray, air brake hose end fittings shall show no base metal corrosion on the end fitting surface except where crimping or the application of labeling information causes a displacement of the protective coating.

S8. *Test procedures—Air brake hose, brake hose assemblies, and brake hose end fittings.*

S8.1 *High temperature resistance test.*

(a) Utilize a small test cylinder with a radius specified in Table IV for the size of hose tested.

(b) Bind the hose around the cylinder and condition it in an air oven for 70 hours at 212 degrees Fahrenheit (100 degrees Celsius).

(c) Cool the hose to room temperature, remove it from the cylinder and straighten it.

(d) Without magnification, examine the hose externally and cut the hose lengthwise and examine the inner tube.

S8.2 *Low temperature resistance test.*

(a) Utilize a large test cylinder with a radius specified in Table IV for the size of hose tested.

(b) Condition the cylinder and the brake hose, in a straight position, in a cold box at minus 40 °F. for 70 hours.

(c) With the hose and cylinder at minus 40 degrees Fahrenheit (minus 40 degrees Celsius), bend the hose 180 degrees around the cylinder at a steady rate in a period of 3 to 5 seconds. Remove the hose from the test cylinder and visibly examine the exterior of the hose for cracks without magnification.

(d) Allow the hose to warm at room temperature for 2 hours. All reusable end fittings are removed from the hose.

All permanently-attached end fittings are cut away from the hose. Cut through one wall of the hose longitudinally along its entire length. Unfold the hose to permit examination of the interior surface. Visibly examine the interior of the hose for cracks without magnification.

S8.3 *Oil resistance test.* Utilize three test specimens and average the results.

S8.3.1 *Preparation.* Fashion a test specimen by cutting a rectangular block 2 inches long and not less than one-third of an inch in width, having a thickness of not more than one-sixteenth inch, from the brake hose and buff the specimen on both faces to ensure smooth surfaces.

S8.3.2 *Measurement.* (a) Weigh each specimen to the nearest milligram in air (W1) and in distilled water (W2) at room temperature. If wetting is necessary to remove air bubbles, dip the specimen in acetone and thoroughly rinse it with distilled water.

(b) Immerse each specimen in ASTM IRM 903 oil for 70 hours at 212 degrees Fahrenheit (100 degrees Celsius) and then cool in ASTM IRM 903 oil at room temperature for 30 to 60 minutes.

(c) Dip the specimen quickly in acetone and blot it lightly with filter paper.

(d) Weigh each specimen in a tared weighing bottle (W3) and in distilled water (W4) within five minutes of removal from the cooling liquid.

(e) Calculate the percentage increase in volume follows:

$$\text{Percent of increase} = \frac{[(W_3 - W_4) - (W_1 - W_2)]}{(W_1 - W_2)} \times 100$$

S8.4 *Ozone resistance test.* Conduct the test specified in S6.8, using air brake hose, except use the large test cylinder specified in Table IV for the size of hose tested.

S8.5 *Length change test.* (a) Position a test hose in a straight, horizontal position, and apply air pressure of 10 psi thereto.

(b) Measure the hose to determine original free length.

(c) Without releasing the 10 psi, raise the air pressure to the test hose to 200 psi.

(d) Measure the hose under 200 psi to determine final free length. An elongation or contraction is an increase or

§571.106

49 CFR Ch. V (10–1–10 Edition)

decrease, respectively, in the final free length from the original free length of the hose.

S8.6 *Adhesion test for air brake hose not reinforced by wire.*

S8.6.1 *Apparatus.* A tension testing machine that is power-driven and that applies a constant rate of extension is used for measuring the force required to separate the layers of the test specimen. The apparatus is constructed so that:

(a) The recording head includes a freely rotating form with an outside diameter substantially the same as the inside diameter of the hose specimen to be placed on it.

(b) The freely rotating form is mounted so that its axis of rotation is in the plane of the ply being separated from the specimen and so that the applied force is perpendicular to the tangent of the specimen circumference at the line of separation.

(c) The rate of travel of the power-actuated grip is a uniform one inch per minute and the capacity of the machine is such that maximum applied tension during the test is not more than 85 percent nor less than 15 percent of the machine's rated capacity.

(d) The machine produces a chart with separation as one coordinate and applied tension as the other.

S8.6.2 *Preparation.* (a) Cut a test specimen of 1 inch or more in length from the hose to be tested and cut the layer to be tested of that test specimen longitudinally along its entire length to the level of contact with the adjacent layer.

(b) Peel the layer to be tested from the adjacent layer to create a flap large enough to permit attachment of the power-actuated clamp of the apparatus.

(c) Mount the test specimen on the freely rotating form with the separated layer attached to the power-actuated clamp.

S8.6.3 [Reserved]

S8.6.4 *Calculations.* (a) The adhesion value shall be the minimum force recorded on the chart excluding that portion of the chart which corresponds to the initial and final 20 percent portion along the displacement axis.

(b) Express the force in pounds per inch of length.

S8.7 *Flex strength and air pressure test.*

S8.7.1 *Apparatus.* A flex testing machine with a fixed hose assembly attachment point and a movable hose assembly attachment point, which meets the dimensional requirements of Figure 5 for the size of hose being tested. The attachment points connect to the end fittings on the hose assembly without leakage and, after the hose assembly has been installed for the flex test, are restrained from rotation. The movable end has a linear travel of 6 inches and a cycle rate of 100 cycles per minute. The machine is capable of increasing the air pressure in the hose assembly from zero to 150 psi within 2 seconds, and decreasing the air pressure in the hose assembly from 150 to zero psi within 2 seconds.

FIGURE 5. FLEX TEST APPARATUS

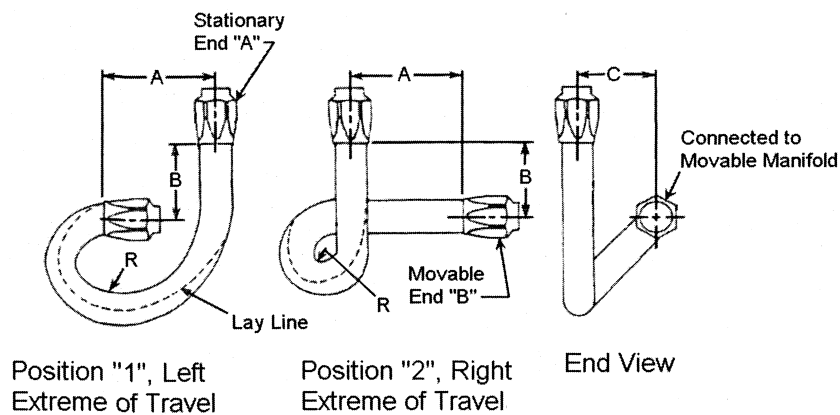

TABLE ACCOMPANYING FIGURE 5—DIMENSIONS IN INCHES (MILLIMETERS)

Free hose length	Nominal hose inside diameter	Dimensions							
		Position "1"				Position "2"			
		A	B	C	R ⁽¹⁾	A	B	C	R ⁽¹⁾
10.00 (254)	3/16, 1/4	3.00 (76)	2.75 (70)	3.75 (95)	1.40 (34)	3.00 (76)	2.75 (70)	3.75 (95)	1.20 (30)
11.00 (279)	5/16, 3/8, 13/32	3.00 (76)	3.50 (89)	4.50 (114)	1.70 (43)	3.00 (76)	3.50 (89)	4.50 (114)	1.30 (33)
14.00 (355)	7/16, 1/2, 5/8	3.00 (76)	4.00 (102)	5.00 (127)	2.20 (56)	3.00 (76)	4.00 (102)	5.00 (127)	1.80 (46)

Note (1): This is an approximate average radius.

S8.7.2 Preparation. (a) Lay the hose material on a flat surface in an unstressed condition. Apply a permanent marking line along the centerline of the hose on the uppermost surface.

(b) Prepare the hose assembly with a free length as shown in the table accompanying Figure 5. The end fittings shall be attached according to the end fitting manufacturer's instructions.

(c) Plug the ends of the hose assembly and conduct the salt spray test in S6.11 using an air brake hose assembly. Remove the plugs from the end fittings.

(d) Within 168 hours of completion of the salt spray test, expose the hose assembly to an air temperature of 212 de-

grees Fahrenheit (100 degrees Celsius) for 70 hours, with the hose in a straight position. Remove the hose and cool it at room temperature for 2 hours. Within 166 hours, subject the hose to the flexure test in S8.7.2(e).

(e) Install the hose assembly on the flex testing machine as follows. With the movable hose attachment point at the mid point of its travel, attach one end of the hose to the movable attachment point with the marked line on the hose in the uppermost position. Attach the other end of the hose to the fixed attachment point allowing the hose to follow its natural curvature.

(f) Cycle the air pressure in the hose by increasing the pressure in the hose

from zero psi to 150 psi and holding constant for one minute, then decreasing the pressure from 150 psi to zero psi and holding constant for one minute. Continue the pressure cycling for the duration of the flex testing. Begin the flex testing by cycling the movable attachment point through 6 inches of travel at a rate of 100 cycles per minute. Stop the flex testing and pressure cycling after one million flex cycles have been completed.

(g) Install an orifice with a hole diameter of 0.0625 inches and a thickness of 0.032 inches in the air pressure supply line to the hose assembly. Provide a gauge or other means to measure air pressure in the hose assembly. Regulate the supply air pressure to the orifice to 150 psi.

(h) Apply 150 psi air pressure to the orifice. After 2 minutes have elapsed, measure the air pressure in the brake hose assembly, while pressurized air continues to be supplied through the orifice.

S8.8 *Corrosion resistance and burst strength test.* (a) Conduct the test specified in S6.11 using an air brake hose assembly. Remove the plugs from the ends of the hose assembly.

(b) Fill the hose assembly with water, allowing all gases to escape. Apply water pressure at a uniform rate of increase of approximately 1,000 psi per minute until the hose ruptures.

S8.9 *Tensile strength test.* Utilize a tension testing machine conforming to the requirements of American Society for Testing and Materials (ASTM) E4-03 "Standard Practices for Force Verification of Testing Machines," and provided with a recording device to measure the force applied.

(a) Attach an air brake hose assembly to the testing machine to permit straight, even, machine pull on the hose. Use adapters to mount hose assemblies equipped with angled end fittings so that the hose is in a straight position when installed on the machine.

(b) Apply tension at a rate of 1 inch per minute travel of the moving head until separation occurs.

S8.10 *Water Absorption and tensile strength test.* Immerse an air brake hose assembly in distilled water at room temperature for 70 hours. Thirty min-

utes after removal from the water, conduct the test specified in S8.9.

S8.11 *Zinc chloride resistance test.* Immerse an air brake hose in a 50 percent zinc chloride aqueous solution at room temperature for 200 hours. Remove it from the solution and examine it under 7-power magnification for cracks.

S8.12 *End fitting corrosion resistance test.* Conduct the test specified in S6.11 using an air brake hose assembly.

S8.13 *Adhesion test for air brake hose reinforced by wire.* (a) Place a steel ball with a diameter equal to 73 percent of the nominal inside diameter of the hose being tested inside of the hose. Plug one end of the hose. Attach the other end of the hose to a source of vacuum.

(b) Subject the hose to a vacuum of 25 inches of Hg for five minutes. With the vacuum still applied to the hose, bend the hose 180 degrees around a large test cylinder with a radius specified in Table IV for the size of hose tested. At the location of this bend, bend the hose 180 degrees around the test cylinder in the opposite direction.

(c) With the vacuum still applied to the hose, return the hose to a straight position. Attempt to roll the ball inside the hose using gravity from one end of the hose to the other end.

S8.14 *Constriction test.* Perform the constriction test in S6.12 using an air brake hose, except that the spherical diameter "A" of the plug gauge in Figure 4, or the diameter of the rigid spherical ball in S6.12.3(a), shall be 66 percent of the nominal inside diameter of the air brake hose being tested.

S9. *Requirements—vacuum brake hose, brake hose assemblies, and brake hose end fittings.*

S9.1 *Labeling.*

S9.1.1 *Hose.* Each vacuum brake hose shall be labeled, or cut from bulk hose that is labeled, at intervals of not more than 6 inches, measured from the end of one legend to the beginning of the next, in block capital letters and numerals at least one-eighth of an inch high, with the information listed in paragraphs (a) through (e) of this section. The information need not be present on hose that is sold as part of a brake hose assembly or a motor vehicle. (a) The symbol DOT, constituting a certification by the hose manufacturer

that the hose conforms to all applicable motor vehicle safety standards.

(b) A designation that identifies the manufacturer of the hose, which shall be filed in writing with: Office of Crash Avoidance Standards, Vehicle Dynamics Division, National Highway Traffic Safety Administration, 400 Seventh Street, SW., Washington, DC 20590. The designation may consist of block capital letters, numerals or a symbol.

(c) The month, day, and year, or the month and year, of manufacture, expressed in numerals. For example, 10/1/96 means October 1, 1996.

(d) The nominal inside diameter of the hose expressed in inches or fractions of inches or in millimeters, or the nominal outside diameter of plastic tubing expressed in inches or fractions of inches or in millimeters followed by the letters OD. The abbreviation "mm" shall follow hose sizes that are expressed in millimeters. (Example of inside diameter: $\frac{7}{32}$, $\frac{1}{4}$, 4 mm. Example of outside diameter: $\frac{1}{4}$ OD, 12 mm OD.)

(e) The letters "VL" or "VH" shall indicate that the component is a light-duty vacuum brake hose or heavy-duty vacuum brake hose, respectively.

S9.1.2 End fittings. Except for an end fitting that is attached by heat shrinking or by interference fit with plastic vacuum hose or that is attached by deformation of the fitting about a hose by crimping or swaging, at least one component of each vacuum brake hose fitting shall be etched, embossed, or stamped in block capital letters and numerals at least one-sixteenth of an inch high with the following information:

(a) The symbol DOT, constituting a certification by the manufacturer of that component that the component conforms to all applicable motor vehicle safety standards.

(b) A designation that identifies the manufacturer of that component of the fitting, which shall be filed in writing with: Office of Crash Avoidance Standards, Vehicle Dynamics Division, National Highway Traffic Safety Administration, 400 Seventh Street, SW., Washington, DC 20590. The designation may consist of block capital letters, numerals or a symbol.

(c) The letters "VL" or "VH" shall indicate that the end fitting is in-

tended for use in a light-duty or heavy-duty vacuum brake system, respectively.

(d) The nominal inside diameter of the hose to which the fitting is properly attached expressed in inches or fractions of inches or in millimeters, or the outside diameter of the plastic tubing to which the fitting is properly attached expressed in inches or fraction of inches or in millimeters followed by the letter OD (See examples in S9.1.1(d)). The abbreviation "mm" shall follow hose sizes that are expressed in millimeters.

S9.1.3 Assemblies. Each vacuum brake hose assembly made with end fittings that are attached by crimping or swaging and each plastic tube assembly made with end fittings that are attached by heat shrinking or dimensional interference fit, except those sold as part of a motor vehicle, shall be labeled by means of a band around the brake hose assembly as specified in this paragraph or, at the option of the manufacturer, by means of labeling as specified in S9.1.3.1. The band may at the manufacturer's option be attached so as to move freely along the length of the assembly, as long as it is retained by the end fittings. The band shall be etched, embossed, or stamped in block capital letters, numerals or symbols at least one-eighth of an inch high, with the following information:

(a) The symbol DOT, constituting certification by the hose assembler that the hose assembly conforms to all applicable motor vehicle safety standards.

(b) A designation that identifies the manufacturer of the hose assembly, which shall be filed in writing with: Office of Crash Avoidance Standards, Vehicle Dynamics Division, National Highway Traffic Safety Administration, 400 Seventh Street SW., Washington, DC 20590. The designation may consist of block capital letters, numerals or a symbol.

S9.1.3.1 At least one end fitting of a vacuum brake hose assembly made with end fittings that are attached by crimping or swaging, or of a plastic tubing assembly made with end fittings that are attached by heat shrinking or dimensional interference fit shall be etched, stamped or embossed with a

designation at least one-sixteenth of an inch high that identifies the manufacturer of the hose assembly and is filed in accordance with S9.1.3(b).

S9.2 *Test requirements.* Each vacuum brake hose assembly or appropriate part thereof shall be capable of meeting any of the requirements set forth under this heading, when tested under the conditions of S13 and the applicable procedures of S10. However, a particular hose assembly or appropriate part thereof need not meet further requirements after having met the constrictor requirement (S9.2.1) and then having been subjected to any one of the requirements specified in S9.2.2 through S9.2.10.

S9.2.1 *Constriction.* Except for that part of an end fitting which does not contain hose, every inside diameter of any section of a vacuum brake hose assembly shall not be less than 75 percent of the nominal inside diameter of the hose if for heavy duty, or 70 percent of the nominal inside diameter of the hose if for light duty (S10.11).

S9.2.2 *High temperature resistance.* A vacuum brake hose tested under the conditions specified in S10.1:

(a) Shall not have collapse of the outside diameter exceeding 10 percent of the initial outside diameter for a heavy-duty vacuum brake hose, or exceeding 15 percent of the initial outside diameter for a light-duty vacuum brake hose;

(b) Shall not show external cracks, charring, or disintegration visible without magnification, and;

(c) Shall not leak when subjected to a hydrostatic pressure test.

S9.2.3 *Low temperature resistance.* A vacuum brake hose tested under the conditions specified in S10.2 shall:

(a) Not show cracks visible without magnification after conditioning at minus 40 degrees Fahrenheit (minus 40 degrees Celsius) for 70 hours when bent around a cylinder having the radius specified in Table V for the size hose tested; and

(b) Not leak when subjected to a hydrostatic pressure test (S10.1(e)).

S9.2.4 *Ozone resistance.* A vacuum brake hose shall not show cracks visible under 7-power magnification after exposure to ozone for 70 hours (S10.3).

S9.2.5 *Burst strength.* A vacuum brake hose shall not rupture under hydrostatic pressure of 350 psi (S10.4).

S9.2.6 *Vacuum.* The collapse of the outside diameter of a vacuum brake hose under internal vacuum of 26 inches of Hg. for five minutes shall not exceed one-sixteenth of an inch (S10.5).

S9.2.7 *Bend.* The collapse of the outside diameter of a vacuum brake hose, other than a preformed vacuum brake hose, at the middle point of the test length when bent until the ends touch shall not exceed the values given in Table V for the size of hose tested (S10.6).

TABLE V—VACUUM BRAKE HOSE TEST REQUIREMENTS

Hose inside diameter*		High temperature resistance		Low temperature resistance		Bend		Deformation—collapsed inside diameter (dimension D), inches
Inches	Millimeters	Hose length, inches	Radius of cylinder, inches	Hose length, inches	Radius of cylinder, inches	Hose length, inches	Maximum collapse of outside diameter, inches	
7/32	5	8	1½	17½	3	7	1¼	3/64
¼	6	9	1½	17½	3	8	3/32	1/16
9/32	9	1¾	19	3½	9	12/64	4/64
11/32	8	9	1¾	19	3½	11	13/64	5/64
3/8	10	10	1¾	19	3½	12	5/32	3/32
7/16	11	2	20½	4	14	17/64	5/64
15/32	11	2	20½	4	14	17/64	5/64
½	12	11	2	20½	4	16	7/32	1/8
5/8	16	12	2¼	22	4½	22	7/32	5/32
¾	14	2½	24	5	28	7/32	3/16
1	16	3¼	28½	6½	36	9/32	¼

*These sizes are listed to provide test values for brake hoses manufactured in these sizes. They do not represent conversions.

S9.2.8 *Swell and adhesion.* Following exposure to Reference Fuel B, every in-

side diameter of any section of a vacuum brake hose shall not be less than 75

percent of the nominal inside diameter of the hose if for heavy duty, or 70 percent of the nominal inside diameter of the hose if for light duty. The vacuum brake hose shall show no leakage in a vacuum test of 26 inches of Hg for 10 minutes. A vacuum hose that is constructed of two or more layers shall withstand a force of 6 pounds per inch of length before separation of adjacent layers. (S10.7).

S9.2.9 *Deformation.* A vacuum brake hose shall return to 90 percent of its original outside diameter within 60 seconds after five applications of force as specified in S10.8, except that a wire-reinforced hose need only return to 85 percent of its original outside diameter. In the case of a heavy duty hose, the first application of force shall not exceed a peak value of 70 pounds, and the fifth application of force shall reach a peak value of at least 40 pounds. In the case of light duty hose the first application of force shall not exceed a peak value of 50 pounds, and the fifth application of force shall reach a peak value of at least 20 pounds (S10.9).

S9.2.10 *End fitting corrosion resistance.* After 24 hours of exposure to salt spray, vacuum brake hose end fittings shall show no base metal corrosion of the end fitting surface except where crimping or the application of labeling information has caused displacement of the protective coating. (S10.10).

S10. *Test procedures—Vacuum brake hose, brake hose assemblies, and brake hose end fittings.*

S10.1 *High temperature resistance test.* (a) Measure the initial outside diameter of the hose.

(b) Subject the hose to an internal vacuum of 26 inches of Hg at an ambient temperature of 257 degrees Fahrenheit (125 degrees Celsius) for a period of 96 hours. Remove the hose to room temperature and atmospheric pressure.

(c) Within 5 minutes of completion of the conditioning in S10.1(b), measure the outside diameter at the point of greatest collapse and calculate the percentage collapse based on the initial outside diameter.

(d) Cool the hose at room temperature for 5 hours. Bend the hose around a mandrel with a diameter equal to five times the initial outside diameter of

the hose. Examine the exterior of the hose for cracks, charring, or disintegration visible without magnification. Remove the hose from the mandrel.

(e) Fill the hose assembly with water, allowing all gases to escape. Apply water pressure in the hose of 175 psi within 10 seconds. Maintain an internal hydrostatic pressure of 175 psi for one minute and examine the hose for visible leakage.

S10.2 *Low temperature resistance test.* (a) Conduct the test specified in S8.2(a) through (c) using vacuum brake hose with the cylinder radius specified in Table V for the size of hose tested.

(b) Remove the hose from the test cylinder, warm the hose at room temperature for 5 hours, and conduct the hydrostatic pressure test in S10.1(e).

S10.3 *Ozone resistance test.* Conduct the test specified in S6.8 using vacuum brake hose.

S10.4 *Burst strength test.* Conduct the test specified in S8.8 using vacuum brake hose.

S10.5 *Vacuum test.* Utilize a 12-inch vacuum brake hose assembly sealed at one end. (a) Measure the hose outside diameter.

(b) Attach the hose to a source of vacuum and subject it to a vacuum of 26 inches of Hg for 5 minutes.

(c) Measure the hose to determine the minimum outside diameter while the hose is still subject to vacuum.

S10.6 *Bend test.* (a) Bend a vacuum brake hose, of the length prescribed in Table V, in the direction of its normal curvature until the ends just touch as shown in Figure 6.

(b) Measure the outside diameter of the specimen at point A before and after bending.

(c) The difference between the two measurements is the collapse of the hose outside diameter on bending.

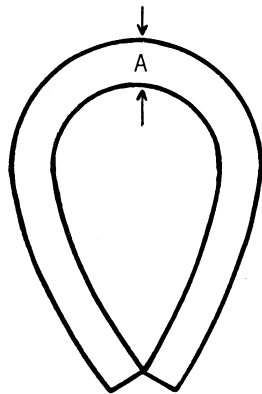

FIG. 6—BEND TEST OF VACUUM BRAKE HOSE.

S10.7 *Swell and adhesion test.* (a) Fill a specimen of vacuum brake hose 12 inches long with ASTM Reference Fuel B as described in ASTM D471–98^{e1} Standard Test Method for Rubber Property—Effect of Liquids. This incorporation by reference was approved by the Director of the Federal Register in accordance with 5 U.S.C. 552(a) and 1 CFR part 51. Copies may be obtained from the American Society for Testing and Materials (ASTM) International, 100 Barr Harbor Drive, P.O. Box C700, West Conshohocken, PA 19428–2959. Copies may be inspected at the National Highway Traffic Safety Administration, Technical Information Services, 400 Seventh St., SW., Plaza Level, Room 403, Washington, DC 20590, or at the National Archives and Records Administration (NARA). For information on the availability of this material at NARA, call 202–741–6030, or go to: http://www.archives.gov/federal_register/code_of_federal_regulations/ibr_locations.html.

(b) Maintain reference fuel in the hose under atmospheric pressure at room temperature for 48 hours.

(c) Remove fuel and conduct the constriction test in S10.11.

(d) Attach the hose to a source of vacuum and subject it to a vacuum of 26 inches of Hg for 10 minutes. Remove the hose from the vacuum source.

(e) For a vacuum brake hose constructed of two or more layers, conduct the test specified in S8.6 using the vacuum brake hose.

S10.8 [Reserved]

S10.9 *Deformation test.* Table VI specifies the test specimen dimensions.

S10.9.1 *Apparatus.* Utilize a compression device, equipped to measure force of at least 100 pounds, and feeler gages of sufficient length to be passed completely through the test specimen.

S10.9.2 *Operation.* (a) Position the test specimen longitudinally in the compression device with the fabric laps not in the line of the applied pressure.

TABLE VI—DIMENSIONS OF TEST SPECIMEN AND FEELER GAGE FOR DEFORMATION TEST

Hose inside diameter*		Specimen dimensions (see Fig. 7)		Feeler gage dimensions	
in.	mm	Depth (inch)	Length (inch)	Width (inch)	Thickness (inch)
7/32	5	3/64	1	1/8	3/64
1/4	6	1/16	1	1/8	1/16
9/32	1/16	1	1/8	1/16
11/32	8	5/64	1	3/16	5/64
3/8	10	3/32	1	3/16	3/32
7/16	5/64	1	1/4	5/64
15/32	5/64	1	1/4	5/64
1/2	12	1/8	1	1/4	1/8
5/8	16	5/32	1	1/4	5/32
3/4	3/16	1	1/4	3/16
1	1/4	1	1/4	1/4

*These sizes are listed to provide test values for brake hoses manufactured in these sizes. They do not represent conversions.

(b) Apply gradually increasing force to the test specimen to compress its inside diameter to that specified in Table VI (dimension D of Figure 7) for the size of hose tested.

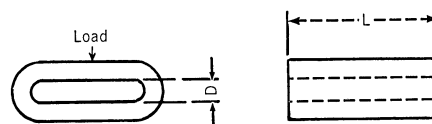

FIG. 7—DEFORMED SPECIMEN OF VACUUM BRAKE HOSE

(c) After 5 seconds release the force and record the peak load applied.

(d) Repeat the procedure four times permitting a 10-second recovery period between load applications.

S10.10 *End fitting corrosion resistance test.* Conduct the test specified in S6.11 using a vacuum brake hose assembly.

S10.11 *Constriction test.* Perform the constriction test in S6.12 using a vacuum brake hose, except that the spherical diameter “A” of the plug gauge in Figure 4, or the diameter of the rigid

spherical ball in S6.12.3(a), shall be 75 percent of the nominal inside diameter of the vacuum brake hose if it is heavy duty, or 70 percent of the nominal inside diameter of the vacuum brake hose if it is light duty.

S11. *Requirements—Plastic air brake tubing, plastic air brake tubing assem-*

blies, and plastic air brake tubing end fittings.

11.1 *Construction.* Each plastic air brake tubing assembly shall be equipped with permanently attached end fittings or reusable end fittings. Plastic air brake tubing shall conform to the dimensional requirements specified in Table VII. (S12.1)

TABLE VII—PLASTIC AIR BRAKE TUBING DIMENSIONS

Nominal tubing outside diameter	Maximum outside diameter		Minimum outside diameter		Nominal inside diameter		Nominal wall thickness		Wall thickness tolerance	
	mm	inches	mm	inches	mm	inches	mm	inches	mm	inches
1/8 inch	3.25	0.128	3.10	0.122	2.01	0.079	0.58	0.023	0.08	0.003
5/32 inch	4.04	0.159	3.89	0.153	2.34	0.092	0.81	0.032	0.08	0.003
3/16 inch	4.83	0.190	4.67	0.184	2.97	0.117	0.89	0.035	0.08	0.003
1/4 inch	6.43	0.253	6.27	0.247	4.32	0.170	1.02	0.040	0.08	0.003
5/16 inch	8.03	0.316	7.82	0.308	5.89	0.232	1.02	0.040	0.10	0.004
3/8 inch	9.63	0.379	9.42	0.371	6.38	0.251	1.57	0.062	0.10	0.004
1/2 inch	12.83	0.505	12.57	0.495	9.55	0.376	1.57	0.062	0.10	0.004
5/8 inch	16.00	0.630	15.75	0.620	11.20	0.441	2.34	0.092	0.13	0.005
3/4 inch	19.18	0.755	18.92	0.745	14.38	0.566	2.34	0.092	0.13	0.005
6 mm	6.10	0.240	5.90	0.232	4.00	0.157	1.00	0.039	0.10	0.004
8 mm	8.10	0.319	7.90	0.311	6.00	0.236	1.00	0.039	0.10	0.004
10 mm	10.13	0.399	9.87	0.389	7.00	0.276	1.50	0.059	0.10	0.004
12 mm	12.13	0.478	11.87	0.467	9.00	0.354	1.50	0.059	0.10	0.004
16 mm	16.13	0.635	15.87	0.625	12.00	0.472	2.00	0.079	0.13	0.005

S11.2 *Labeling.*

S11.2.1 *Plastic air brake tubing.* Plastic air brake tubing shall be labeled, or cut from bulk tubing that is labeled, at intervals of not more than 6 inches, measured from the end of one legend to the beginning of the next, in block capital letters and numerals at least one-eighth of an inch high, with the information listed in paragraphs (a) through (e) of this section. The information need not be present on tubing that is sold as part of a motor vehicle.

(a) The symbol DOT, constituting a certification by the hose manufacturer that the hose conforms to all applicable motor vehicle safety standards.

(b) A designation that identifies the manufacturer of the tubing, which shall be filed in writing with: Office of Vehicle Safety Compliance, Equipment Division NVS-222, National Highway Traffic Safety Administration, 400 Seventh St. SW., Washington, DC 20590. The designation may consist of block capital letters, numerals, or a symbol.

(c) The month, day, and year, or the month and year, of manufacture, expressed in numerals. For example, 10/1/96 means October 1, 1996.

(d) The nominal outside diameter expressed in inches or fractions of inches or in millimeters followed by the letters OD. The abbreviation "mm" shall follow tubing sizes that are expressed in millimeters. (Examples: 3/8 OD, 6 mm OD.)

(e) The letter "A" shall indicate intended use in air brake systems.

S11.2.2 *End fittings.* Except for an end fitting that is attached by deformation of the fitting about the tubing by crimping or swaging, at least one component of each plastic air brake tubing end fitting shall be etched, embossed, or stamped in block capital letters and numerals at least one-sixteenth of an inch high with the following information:

(a) The symbol DOT, constituting a certification by the manufacturer that the end fitting conforms to all applicable motor vehicle safety standards.

(b) A designation that identifies the manufacturer of the end fitting, which shall be filed in writing with: Office of Vehicle Safety Compliance, Equipment Division NVS-222, National Highway Traffic Safety Administration, 400 Seventh St. SW., Washington, DC 20590.

The designation may consist of block capital letters, numerals, or a symbol.

(c) The letter “A” shall indicate intended use in air brake systems.

(d) The nominal outside diameter of the plastic tubing to which the fitting is properly attached expressed in inches or fractions of inches or in millimeters followed by the letters OD. The abbreviation “mm” shall follow tubing sizes that are expressed in millimeters. (Examples: 3/8 OD, 6 mm OD)

S11.2.3. *Assemblies.* Each plastic air brake tubing assembly made with end fittings that are attached by crimping or swaging, except those sold as part of a motor vehicle, shall be labeled by means of a band around the brake tubing assembly as specified in this paragraph or, at the option of the manufacturer, by means of labeling as specified in S11.2.3.1. The band may at the manufacturer’s option be attached so as to move freely along the length of the assembly, as long as it is retained by the end fittings. The band shall be etched, embossed, or stamped in block capital letters, numerals or symbols at least one-eighth of an inch high, with the following information:

(a) The symbol DOT, constituting certification by the tubing assembler that the tubing assembly conforms to all applicable motor vehicle safety standards.

(b) A designation that identifies the manufacturer of the hose assembly, which shall be filed in writing with: Office of Vehicle Safety Compliance, Equipment Division NVS–222, National Highway Traffic Safety Administration, 400 Seventh St. SW., Washington, DC 20590. The designation may consist of block capital letters, numerals, or a symbol.

S11.2.3.1 At least one end fitting of a plastic air brake tubing assembly made with end fittings that are attached by crimping or swaging shall be etched, stamped, or embossed with a designation at least one-sixteenth of an inch

high that identifies the manufacturer of the tubing assembly and is filed in accordance with S11.2.3(b).

S11.3 *Test requirements.* Each plastic air brake tubing assembly or appropriate part thereof shall be capable of meeting any of the requirements set forth under this heading, when tested under the conditions of S13 and the applicable procedures of S12. However, a particular tubing assembly or appropriate part thereof need not meet further requirements after having met the constriction requirement (S11.3.1) and then having been subjected to any one of the requirements specified in S11.3.2 through S11.3.24. Unless otherwise specified, testing is conducted on a sample of tubing 12 inches in length.

S11.3.1 *Constriction.* Every inside diameter of any section of a plastic air brake tubing assembly shall not be less than 66 percent of the nominal inside diameter of the brake tubing. (S12.2)

S11.3.2 *High temperature conditioning and dimensional stability.* Plastic air brake tubing shall conform to the dimensions in Table VII after conditioning in air at 230 degrees Fahrenheit (110 degrees Celsius) for four hours. (S12.3)

S11.3.3 *Boiling water conditioning and dimensional stability.* Plastic air brake tubing shall conform to the dimensions in Table VII after conditioning in boiling water for two hours. (S12.4)

S11.3.4 *Burst Strength.* Plastic air brake tubing shall not rupture when subjected to the burst strength pressure in Table VIII for the size of tubing being tested. (S12.5)

S11.3.5 *Moisture absorption and burst strength.* Plastic air brake tubing shall not rupture when subjected to 80 percent of the burst strength pressure in Table VIII, after the tubing has been dried in an oven and then conditioned in a 100 percent relative humidity atmosphere at 75 degrees Fahrenheit (24 degrees Celsius) for 100 hours. (S12.6)

TABLE VIII—PLASTIC AIR BRAKE TUBING MECHANICAL PROPERTIES

Nominal tubing OD	Burst strength pressure		Supported bend radius ¹		Unsupported bend radius ²		Conditioned tensile load	
	kPa	Psi	Mm	inches	mm	inches	N	lbf
1/8 inch	6900	1000	9.4	0.37	9.4	0.37	156	35
5/32 inch	8300	1200	12.7	0.50	12.7	0.50	178	40
3/16 inch	8300	1200	19.1	0.75	19.1	0.75	222	50

TABLE VIII—PLASTIC AIR BRAKE TUBING MECHANICAL PROPERTIES—Continued

Nominal tubing OD	Burst strength pressure		Supported bend radius ¹		Unsupported bend radius ²		Conditioned tensile load	
	kPa	Psi	Mm	inches	mm	inches	N	lbf
¼ inch	8300	1200	25.4	1.00	25.4	1.00	222	50
⅜ inch	6900	1000	31.8	1.25	38.1	1.50	334	75
½ inch	9700	1400	38.1	1.50	38.1	1.50	667	150
⅝ inch	6600	950	50.8	2.00	63.5	2.50	890	200
¾ inch	6200	900	63.5	2.50	76.2	3.00	1446	325
1 inch	5500	800	76.2	3.00	88.9	3.50	1557	350
6 mm	7600	1100	20.0	0.75	25.4	1.00	222	50
8 mm	6200	900	31.8	1.25	38.1	1.50	334	75
10 mm	8200	1200	38.1	1.50	38.1	1.50	667	150
12 mm	6900	1000	44.5	1.75	63.5	2.50	890	200
16 mm	6000	875	69.9	2.75	76.2	3.00	1446	325

NOTES: (1) Supported bend radius for tests specifying cylinders around which the tubing is bent. (2) Unsupported bend radius for the collapse resistance test in which the tubing is not supported by a cylinder during bending.

S11.3.6 *Ultraviolet light resistance.* Plastic air brake tubing shall not rupture when subjected to 80 percent of the burst strength pressure in Table VIII for the size of tubing being tested, after being exposed to ultraviolet light for 300 hours and then impacted with a one pound weight dropped from a height of 12 inches. (S12.7)

S11.3.7 *Low temperature flexibility.* The outer surface of plastic air brake tubing shall not show cracks visible without magnification as a result of conditioning in air at 230 degrees Fahrenheit (110 degrees Celsius) for 24 hours, and then conditioning in air at minus 40 degrees Fahrenheit (minus 40 degrees Celsius) for four hours, and then bending the tubing 180 degrees around a test cylinder having a radius equal to six times the nominal outside diameter of the tubing. (S12.8)

S11.3.8 *High temperature flexibility.* Plastic air brake tubing shall not rupture or burst when subjected to 80 percent of the burst strength pressure in Table VIII for the size of tubing being tested, after the tubing has been:

- (a) Conditioned in air at 230 degrees Fahrenheit (110 degrees Celsius) for 72 hours while bent 180 degrees around a cylinder having a radius equal to the supported bend radius in Table VIII for the size of tubing being tested; and
- (b) Cooled to room temperature while remaining on the cylinder, then straightened; and
- (c) Bent 180 degrees around the cylinder in the opposite direction of the first bending. (S12.9)

S11.3.9 *High temperature resistance.* Plastic air brake tubing shall not rupture or burst when subjected to 80 percent of the burst strength pressure in Table VIII for the size of tubing being tested, after the tubing has been conditioned in air at 230 degrees Fahrenheit (110 degrees Celsius) for 72 hours. (S12.10)

S11.3.10 *High temperature conditioning, low temperature impact resistance.* Plastic air brake tubing shall not rupture or burst when subjected to 80 percent of the burst strength pressure in Table VIII for the size of tubing being tested, after the tubing has been conditioned in air at 230 degrees Fahrenheit (110 degrees Celsius) for 24 hours, then conditioned in air at minus 40 degrees Fahrenheit (minus 40 degrees Celsius) for 4 hours and impacted with a one pound weight dropped from a height of 12 inches. (S12.11)

S11.3.11 *Boiling water conditioning, low temperature impact resistance.* Plastic air brake tubing shall not rupture when subjected to 80 percent of the burst strength pressure in Table VIII for the size of tubing being tested, after the tubing has been conditioned in boiling water for two hours, then conditioned in air at minus 40 degrees Fahrenheit (minus 40 degrees Celsius) for 4 hours, and then impacted with a one pound weight dropped from a height of 12 inches. (S12.12)

S11.3.12 *Zinc chloride resistance.* The outer surface of plastic air brake tubing shall not show cracks visible under 7-power magnification after immersion in a 50 percent zinc chloride aqueous

solution for 200 hours while bent around a cylinder having a radius equal to the supported bend radius in Table VIII for the size of tubing tested. (S12.13)

S11.3.13 *Methyl alcohol resistance.* The outer surface of plastic air brake tubing shall not show cracks visible under 7-power magnification after immersion in a 95 percent methyl alcohol aqueous solution for 200 hours while bent around a cylinder having a radius equal to the supported bend radius in Table VIII for the size of tubing tested. (S12.14)

S11.3.14 *High temperature conditioning and collapse resistance.* The collapse of the outside diameter of plastic air brake tubing shall not exceed twenty percent of the original outside diameter when bent 180 degrees on a holding fixture to the unsupported bend radius specified in Table VIII and conditioned in air at 200 degrees Fahrenheit (93 degrees Celsius) for 24 hours. (S12.15)

S11.3.15 *Ozone resistance.* The outer surface of plastic air brake tubing shall not show cracks visible under 7-power magnification after exposure to ozone for 70 hours at 104 degrees Fahrenheit (40 degrees Celsius). (S12.16)

S11.3.16 *Oil resistance.* Plastic air brake tubing shall not rupture when subjected to 80 percent of the burst strength pressure in Table VIII for the size of tubing being tested, after the tubing has been conditioned in ASTM IRM 903 oil at 212 degrees Fahrenheit (100 degrees Celsius) for 70 hours. (S12.17)

S11.3.17 *Tensile strength.* A plastic air brake tubing assembly designed for use between frame and axle or between a towed and a towing vehicle shall withstand, without separation of the tubing from its end fittings, a pull of 250 pounds if it is $\frac{3}{8}$ inch, 10 mm, or less in nominal outside diameter, or a pull of 325 pounds if it is larger than $\frac{3}{8}$ inch or 10 mm in nominal outside diameter. A plastic air brake tubing assembly designed for use in any other application shall withstand, without separation of the hose from its end fittings, a pull of 35 pounds if it is $\frac{1}{8}$ inch, 3 mm, or less in nominal outside diameter, 40 pounds if it is $\frac{5}{32}$ inch or 4 mm in nominal outside diameter, 50

pounds if it is $\frac{3}{16}$ to $\frac{3}{8}$ inch or 5 mm to 10 mm in nominal outside diameter, 150 pounds if it is $\frac{1}{2}$ to $\frac{5}{8}$ inch or 11 mm to 16 mm in nominal outside diameter, or 325 pounds if it is larger than $\frac{5}{8}$ inch or 16 mm in nominal outside diameter. (S12.18)

S11.3.18 *Boiling water conditioning and tensile strength.* A plastic air brake tubing assembly when subjected to a tensile pull test shall either elongate 50 percent or withstand the conditioned tensile load in Table VIII without separation from its end fittings, with one end of the assembly conditioned in boiling water for 5 minutes. (S12.19)

S11.3.19 *Thermal conditioning and tensile strength.* A plastic air brake tubing assembly when subjected to a tensile pull test shall either elongate 50 percent or withstand the conditioned tensile load in Table VIII without separation from its end fittings after the assembly has been subjected to four cycles of conditioning in air at minus 40 degrees Fahrenheit (minus 40 degrees Celsius) for thirty minutes, normalizing at room temperature, conditioning in boiling water for 15 minutes, and normalizing at room temperature. (S12.20)

S11.3.20 *Vibration resistance.* A plastic air brake tubing assembly with an internal air pressure of 120 psig shall not rupture or leak more than 50 cm³ per minute at a temperature of minus 40 degrees Fahrenheit (minus 40 degrees Celsius) and 25 cm³ per minute at a temperature of 75 degrees Fahrenheit (24 degrees Celsius), after the assembly has been subjected to 1,000,000 cycles of vibration testing with one end of the assembly fixed and the other end stroked $\frac{1}{2}$ -inch at 600 cycles per minute. In addition, end fittings that use a threaded retention nut shall retain at least 20 percent of the original retention nut tightening torque upon completion of the vibration testing. The vibration test shall be conducted in an environmental chamber and the air temperature shall be cycled between minus 40 degrees Fahrenheit (minus 40 degrees Celsius) and 220 degrees Fahrenheit (104 degrees Celsius) during the test. (S12.21)

S11.3.21 *End fitting retention.* The end fittings of a plastic air brake tubing assembly shall not rupture when the assembly is filled with water and pressurized to the burst strength pressure in Table VIII. (S12.22)

S11.3.22 *Thermal conditioning and end fitting retention.* The end fittings of a plastic air brake tubing assembly shall not rupture when the tubing assembly is filled with ASTM IRM 903 oil and:

(a) Conditioning in air at 200 degrees Fahrenheit (93 degrees Celsius) for 24 hours with atmospheric pressure inside the tubing assembly; and

(b) Increasing the pressure inside the tubing assembly to 450 psi, and holding this pressure for five minutes while maintaining an air temperature of 200 degrees Fahrenheit (93 degrees Celsius); and

(c) Reducing the pressure inside the tubing assembly to atmospheric and permitting the tubing assembly to cool at 75 degrees Fahrenheit (24 degrees Celsius) for 1 hour; and

(d) Conditioning the tubing assembly in air at minus 40 degrees Fahrenheit (minus 40 degrees Celsius) for 24 hours with atmospheric pressure inside the tubing assembly; and

(e) Increasing the pressure inside the tubing assembly to 450 psi, and holding this pressure for five minutes while maintaining an air temperature of minus 40 degrees Fahrenheit (minus 40 degrees Celsius). (S12.23)

S11.3.23 *End fitting serviceability.* A plastic air brake end fitting that uses a threaded retention nut shall not rupture or leak more than 25 cm³ per minute when pressurized to 120 psi after five assembly cycles. (S12.24)

S11.3.24 *End fitting corrosion resistance.* After 24 hours of exposure to salt spray, air brake hose end fittings shall show no base metal corrosion on the end fitting surface except where crimping or the application of labeling information causes a displacement of the protective coating. (S12.25)

S12. *Test procedures—Plastic air brake tubing, plastic air brake tubing assemblies, plastic air brake tubing end fittings.*

S12.1 *Air brake tubing dimensions.* Measure the tubing dimensions including wall thickness, inside diameter, and outside diameter, using appropriate metrology apparatus such as mi-

croimeters, dial indicators and gauges, or optical comparators. To account for slight out-of-round conditions, diameter measurements may be calculated using the average of the major and minor diameters.

S12.2 *Constriction test.* Perform the constriction test in S6.12 using an air brake tubing assembly, except that the spherical diameter "A" of the plug gauge in Figure 4, or the diameter of the rigid spherical ball in S6.12.3(a), shall be 66 percent of the nominal inside diameter of the tubing as specified in Table VII.

S12.3 *High temperature conditioning and dimensional stability test.* (a) Condition the tubing at 230 degrees Fahrenheit (110 degrees Celsius) for 4 hours in an air oven.

(b) Remove the tubing from the oven and allow to cool at room temperature for 30 minutes.

(c) Measure the dimensions of the tubing using the procedure in S12.1.

S12.4 *Boiling water conditioning and dimensional stability test.* (a) Utilize a container constructed of a non-reactive material large enough so that the tubing to be tested does not touch any surface of the container. Fill container with distilled water.

(b) Slip the tubing over a stainless steel wire for positioning it in the pot.

(c) Bring the water to a boil. Place the tubing in the water and position it so that it does not touch the container. Boil the tubing for two hours. Replenish the water as necessary, adding it slowly so that the water in the pot boils continuously.

(d) Remove the tubing from the water and allow to cool at room temperature for 30 minutes. Wipe off any water that remains on the tubing.

(e) Measure the dimensions of the tubing using the procedure in S12.1.

S12.5 *Burst strength test.* (a) Utilize an air brake tubing assembly or prepare a 12 inch length of tubing and install end fittings according to the end fitting manufacturer's instructions.

(b) Plug one end of the assembly, fill it with water, and connect the other end to a source of water pressure. Bleed any air from the assembly and water pressure system.

(c) Increase the water pressure inside the tubing assembly at a rate of 3,000

psi per minute to the burst strength pressure for the size of tubing being tested as specified in Table VIII.

S12.6 *Moisture absorption and burst strength.* (a) Prepare a sample of tubing twelve inches in length.

(b) Condition the tubing at 230 degrees Fahrenheit (110 degrees Celsius) for 24 hours in an air oven. Remove the tubing from the oven and within 30 seconds, and weigh it to establish the initial weight. The weight shall be measured with a resolution of 0.01 gram; if the scale has a higher resolution, then values of 0.005 gram and above shall be rounded to the nearest 0.01 gram and values below 0.005 gram shall be truncated.

(c) Place the tubing in an environmental chamber and condition it for 100 hours at 100 percent relative humidity and a temperature of 75 degrees Fahrenheit (24 degrees Celsius).

(d) Remove the tubing from the chamber and within a period of 5 minutes, remove all surface moisture from the tubing using cloth and weigh the tubing to establish the conditioned weight. Weight shall be measured to the nearest 0.01 gram as in S12.6(b).

(e) Calculate percentage of moisture absorption as follows:

$$\frac{([\text{Conditioned Weight} - \text{Initial Weight}] \div [\text{Initial Weight}]) \times 100}{}$$

(f) Install end fittings according to the end fitting manufacturers instructions.

(g) Conduct the burst strength test in S12.5 except use 80 percent of the burst strength pressure for the size of tubing being tested as specified in Table VIII.

S12.7 *Ultraviolet light resistance test.*

(a) *Apparatus.* An accelerated weathering test machine for ultraviolet light conditioning of plastic air brake tubing. The machine shall be equipped with fluorescent UVA-340 light bulbs and automatic irradiance control. Also utilize an impact test apparatus as shown in Figure 8.

(b) *Test standards.* The testing is in accordance with American Society for Testing and Materials (ASTM) G154-00 "Standard Practice for Operating Fluorescent Light Apparatus for UV Exposure of Nonmetallic Materials;" ASTM G151-97 "Standard Practice for Exposing Nonmetallic Materials in Accelerated Test Devices that Use Laboratory

Light Sources," and; ASTM D4329-99 "Standard Practice for Fluorescent UV Exposure of Plastics." These incorporations by reference were approved by the Director of the Federal Register in accordance with 5 U.S.C. 552(a) and 1 CFR Part 51. Copies may be obtained from the American Society for Testing and Materials (ASTM) International, 100 Barr Harbor Drive, P.O. Box C700, West Conshohocken, PA 19428-2959. Copies may be inspected at the National Highway Traffic Safety Administration, Technical Information Services, 400 Seventh St., SW., Plaza Level, Room 403, Washington, DC 20590, or at the National Archives and Records Administration (NARA). For information on the availability of this material at NARA, call (202) 741-6030, or go to: http://www.archives.gov/federal_register/code_of_federal_regulations/ibr_locations.html.

(c) *Preparation.* (1) Utilize a 12 inch length of plastic air brake tubing. Mask 1 inch of each end of the tubing where end fittings will be attached using opaque tape.

(2) Attach the tubing to the test rack of the machine, securing it at the ends along the masked sections. Wipe the outside surface of the tubing with acetone to remove any surface contaminants. Place the tubing and rack in the accelerated weathering test machine so that the center of the tubing assembly is approximately in the center of the UV light exposure area of the test machine. (If multiple plastic brake tubing assemblies are tested, then their position in the machine should be rotated according to ASTM D4329-99 S7.4.1, except the rotation shall be each 96 hours instead of weekly.) The distance from the light bulb to the tubing shall be approximately 2 inches. Set the UV irradiance to 0.85 watts per square meter at 340 nm and maintain this level during the testing. Maintain a temperature inside the test chamber of 113 degrees Fahrenheit (45 degrees Celsius), and use only atmospheric humidity. Expose the tubing at this UV irradiance level for 300 hours continuously. Remove the tubing from the test chamber.

(3) Place the tubing inside the impact test apparatus, and drop the impacter

onto the tubing from a height of 12 inches.

(4) Remove the masking material from the ends of the tubing. Install end fittings according to the end fitting

manufacturer's instructions. Conduct the burst strength test in S12.5 except use 80 percent of the burst strength pressure for the size of tubing being tested as specified in Table VIII.

FIGURE 8. IMPACT TEST APPARATUS

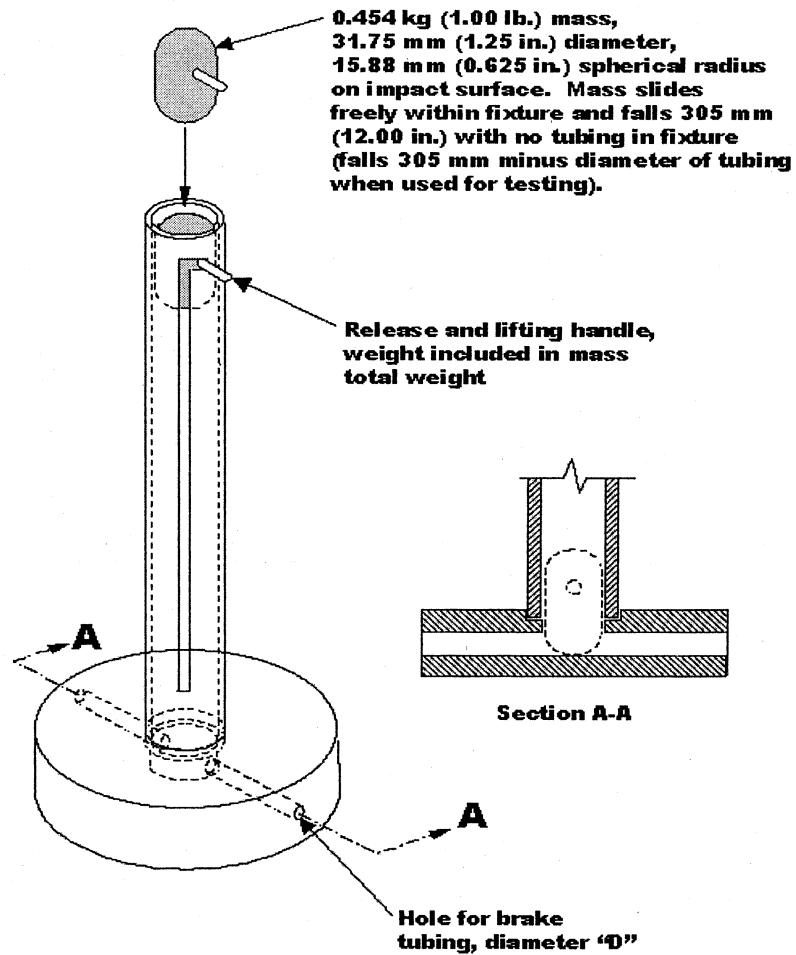

TABLE ACCOMPANYING FIGURE 8

Nominal tubing outside diameter	Hole diameter "D"	
	mm	Inches
1/8 inch	3.96	0.156
9/32 inch	4.75	0.187
3/16 inch	5.54	0.218
1/4 inch	7.14	0.281
5/16 inch	8.71	0.343
3/8 inch	10.31	0.406
1/2 inch	13.49	0.531
5/8 inch	16.66	0.656
3/4 inch	20.32	0.800
6 mm	6.80	0.268
8 mm	8.80	0.346
10 mm	10.80	0.425
12 mm	12.80	0.504
16 mm	16.80	0.661

S12.8 *Low temperature flexibility test.*
 (a) Utilize a cylinder having a radius of six times the nominal outside diameter of the tubing.

(b) Condition the tubing in an air oven at 230 degrees Fahrenheit (110 degrees Celsius) for 24 hours. Remove from the oven and cool at room temperature for 30 minutes.

(c) Condition the cylinder and the tubing in an environmental chamber at minus 40 degrees Fahrenheit (minus 40 degrees Celsius) for four hours.

(d) With the tubing and test cylinder at minus 40 degrees Fahrenheit (minus 40 degrees Celsius), bend the tubing 180 degrees around the cylinder at a steady rate in a period of 4 to 8 seconds.

S12.9 *High temperature flexibility test.*
 (a) Utilize a cylinder having a radius equal to the supported bend radius in Table VIII for the size of tubing being tested.

(b) Bend the tubing 180 degrees around the cylinder and hold in place with a clamp or other suitable support, applying only enough force on the tubing to hold it in position.

(c) Condition the tubing and cylinder in an air oven at 230 degrees Fahrenheit (110 degrees Celsius) for 72 hours. Remove the tubing and cylinder from the oven and cool at room temperature for two hours.

(d) Remove the clamps or supports from the tubing and straighten the tubing at a steady rate in a period of 4 to 8 seconds.

(e) Rebend the tubing 180 degrees around the cylinder, at the same point but in the opposite direction of the

bending in S12.9(b), at a steady rate in a period of 4 to 8 seconds.

(f) Conduct the burst strength test in S12.5 except use 80 percent of the burst strength pressure for the size of tubing being tested as specified in Table VIII.

S12.10 *High temperature resistance test.* Condition the tubing in an air oven at 230 degrees Fahrenheit (110 degrees Celsius) for 72 hours. Remove the tubing and allow to cool at room temperature for 30 minutes. Conduct the burst strength test in S12.5 except use 80 percent of the burst strength pressure for the size of tubing being tested as specified in Table VIII.

S12.11 *High temperature conditioning, low temperature impact resistance test.* (a) *Apparatus.* Utilize an impact test apparatus as shown in Figure 8.

(b) Condition the tubing in an air oven at 230 degrees Fahrenheit (110 degrees Celsius) for 72 hours. Remove the tubing and allow to cool at room temperature for 30 minutes.

(c) Condition the tubing and the impact test apparatus in an environmental chamber at minus 40 degrees Fahrenheit (minus 40 degrees Celsius) for 4 hours.

(d) With the tubing and impact test apparatus at minus 40 degrees Fahrenheit (minus 40 degrees Celsius), place the tubing inside the apparatus and drop the impacter onto the tubing from a height of 12 inches. Remove the tubing from the chamber and allow to warm at room temperature for one hour.

(e) Conduct the burst strength test in S12.5 except use 80 percent of the burst strength pressure for the size of tubing being tested as specified in Table VIII.

S12.12 *Boiling water conditioning, low temperature impact resistance test.* (a) *Apparatus.* Utilize an impact test apparatus as shown in Figure 8.

(b) Condition the tubing in boiling water using the test in S12.4 (a) through (d), except that the length of tubing shall be 12 inches.

(c) Condition the tubing and the impact test apparatus in an environmental chamber at minus 40 degrees Fahrenheit (minus 40 degrees Celsius) for 4 hours.

(d) With the tubing and impact test apparatus at minus 40 degrees Fahrenheit (minus 40 degrees Celsius), place

the tubing inside the apparatus and drop the impacter onto the tubing from a height of 12 inches. Remove the tubing from the chamber and allow to warm at room temperature for one hour.

(e) Conduct the burst strength test in S12.5 except use 80 percent of the burst strength pressure for the size of tubing being tested as specified in Table VIII.

S12.13 *Zinc chloride resistance test.* (a) Utilize a cylinder having a radius equal to the supported bend radius in Table VIII for the size of tubing being tested. The cylinder is constructed of a non-reactive material or coated to prevent chemical reaction with zinc chloride. The length of the tubing sample is long enough so that its ends will not be submerged during the immersion in zinc chloride, or the ends of the tubing are plugged to keep the zinc chloride from entering the tubing.

(b) Bend the tubing 180 degrees around the cylinder and hold in place with a clamp or other suitable support constructed of non-reactive materials, applying only enough force on the tubing to hold it in position.

(c) Immerse the tubing and cylinder in a 50 percent zinc chloride aqueous solution at room temperature for 200 hours.

(d) Remove the tubing and cylinder from the solution. While still on the test cylinder, inspect the tubing under 7-power magnification for cracks.

S12.14 *Methyl alcohol resistance.* (a) Utilize a cylinder having a radius equal to the supported bend radius in Table VIII for the size of tubing being tested. The cylinder is constructed of a non-reactive material or coated to prevent chemical reaction with methyl alcohol.

(b) Bend the tubing 180 degrees around the cylinder and hold in place with a clamp or other suitable support constructed of non-reactive materials, applying only enough force on the tubing to hold it in position. The ends of the tubing may be shortened so that they will be fully submerged in the methyl alcohol.

(c) Immerse the tubing and cylinder in a 95 percent methyl alcohol aqueous solution at room temperature for 200 hours.

(d) Remove the tubing and cylinder from the solution. While still on the

test cylinder, inspect the tubing under 7-power magnification for cracks.

S12.15 *High temperature conditioning and collapse resistance test.* (a) *Apparatus.* A holding device consisting of two vertical pins affixed to a flat, horizontal plate. Each pin projects 1 inch above the top surface of the plate. The diameter of each pin is approximately equal to the inside diameter of the tubing being tested. Using the unsupported bend radius for the size of tubing being tested from Table VIII, the distance between the pin centerlines is equal to:

$[2 \times \text{unsupported bend radius}] + [\text{nominal OD of tubing}]$

(b) *Preparation.* (1) Use the unsupported bend radius for the size of tubing being tested from Table VIII and cut the tubing to the following length:

$[3.14 \times [\text{unsupported bend radius}]] + [10 \times [\text{nominal tubing OD}]] + 2 \text{ inches}$

or

$[3.14 \times [\text{unsupported bend radius}]] + [10 \times [\text{nominal tubing OD}]] + 50 \text{ mm}$

(2) Place a reference mark at the center of the sample. At this mark, measure the initial outside diameter of the tubing. If the tubing is slightly out-of-round, use the elliptical minor diameter as the initial outside diameter.

(3) Install the tubing completely over the pins of the holding device so that the tubing is bent 180 degrees. If the tubing has a natural curvature, the tubing shall be bent in the direction of the natural curvature.

(4) Condition the holding device and tubing in an air oven at 200 degrees Fahrenheit (93 degrees Celsius) for 24 hours. Remove the holding device and tubing and allow to cool at room temperature for thirty minutes.

(5) With the tubing still mounted to the holding device, measure the elliptical minor diameter of the tubing at the reference mark to determine the final outside diameter.

(c) *Calculation.* Calculate the percentage collapse of the outside diameter of the tubing as follows: $([\text{Initial Outside Diameter} - \text{Final Outside Diameter}] \div [\text{Initial Outside Diameter}]) \times 100$

S12.16 *Ozone resistance test.* Conduct the test specified in S6.8 using plastic air brake tubing.

S12.17 *Oil resistance test.* (a) Utilize a plastic air brake tubing assembly or prepare a 12 inch length of tubing and install end fittings according to the end fitting manufacturer's instructions.

(b) Immerse the tubing in ASTM IRM 903 oil at 212 degrees Fahrenheit (100 degrees Celsius) for 70 hours. Remove and allow to cool at room temperature for 30 minutes. Wipe any excess oil from the tubing assembly.

(c) Conduct the burst strength test in S12.5 except use 80 percent of the burst strength pressure for the size of tubing being tested as specified in Table VIII and, at the manufacturer's option, oil may be used as the test medium instead of water.

S12.18 *Tensile strength test.* Conduct the test in S8.9 using a plastic air brake tubing assembly or an assembly prepared from a 12 inch length of air brake tubing with end fittings installed according to the end fitting manufacturer's instructions.

S12.19 *Boiling water conditioning and tensile strength.* (a) *Apparatus.* Use a tension testing machine as specified in S8.9. The lower attachment point of the machine is equipped with a heated, open-top container that is water tight. The inside of the container (lower attachment point) and upper attachment point of the machine have provisions to quickly attach a brake hose assembly for tensile testing.

(b) *Preparation.* Prepare an air brake tubing assembly with a free length of 6 inches (six inches of exposed tubing between the end fittings), with the end fittings installed in accordance with the end fitting manufacturer's instructions. If necessary install adapters on the end fittings to permit quick attachment to the machine, to keep water from entering the tubing assembly, and to ensure that the tubing assembly is in a straight position when installed on the machine. Fill the container with distilled water such that the lower 4 inches of exposed tubing will be submerged when the brake tubing assembly is installed on the machine. Heat the water until it boils. Then quickly install the plastic air brake tubing assembly on the machine with the lower end of the tubing assembly in the boiling water. After the

water has boiled continuously for 5 minutes, apply tension to the tubing assembly at a rate of 1 inch per minute travel of the moving head until either the conditioned tensile load in Table VIII for the size of tubing being tested is reached or the free length of the tubing assembly reaches 9 inches, whichever occurs first.

S12.20 *Thermal conditioning and tensile strength—(a) Apparatus.* Use a tension testing machine as specified in S8.9.

(b) *Preparation.* Prepare an air brake tubing assembly with a free length of 6 inches (six inches of exposed tubing between the end fittings), with the end fittings installed in accordance with the end fitting manufacturer's instructions. If necessary install adapters on the end fittings to permit attachment to the machine, to keep water from entering the tubing assembly, and/or to ensure that the tubing assembly is in a straight position when installed on the machine. Subject the tubing assembly to four complete cycles of the following sequence:

(1) Condition the tubing assembly in an environmental chamber at minus 40 degrees Fahrenheit (minus 40 degrees Celsius) for 30 minutes. Remove from the chamber and allow to warm at room temperature for 30 minutes.

(2) Condition the tubing assembly by submerging it in boiling water for 15 minutes. Remove and allow to cool at room temperature for 30 minutes. Install the tubing assembly on the tension testing machine and apply tension to the tubing assembly at a rate of one inch per minute travel of the moving head until either the conditioned tensile load in Table VIII for the size of tubing being tested is reached or the free length of the tubing assembly reaches 9 inches, whichever occurs first.

S12.21 *Vibration resistance test.* (a) *Apparatus.* A vibration testing machine that supports a brake tubing assembly by its end fittings in approximately a straight line and includes the following features:

(1) One tubing assembly attachment point is fixed and the other moves in a plane perpendicular to a line projected between the attachment points. The movable attachment point moves in a

linear direction and travels $\frac{1}{2}$ inch total and at its midpoint of travel falls on a line projected between the attachment points. The movable attachment point has a cycle rate of 600 cycles per minute.

(2) The distance between the attachment points is adjustable to compensate for varying lengths of brake tubing assemblies.

(3) The actuating mechanism for the movable attachment point is balanced to prevent introduction of machine vibration into the brake tubing assembly.

(4) The machine has a compressed air supply system that pressurizes the air brake tubing assembly through one fitting while the other fitting is plugged. The machine's compressed air supply system includes a pressure gauge or monitoring system and an air flow meter.

(5) The machine is constructed so that an air brake tubing assembly mounted on it can be conditioned in an environmental test chamber.

(b) *Preparation.* (1) Prepare an air brake tubing assembly with a free length of 18 inches (18 inches of exposed tubing between the end fittings), with the end fittings installed in accordance with the end fitting manufacturer's instructions. Record the initial tightening torque for an end fitting that uses a threaded retaining nut.

(2) Install the air brake tubing assembly on the vibration testing machine and, with the movable attachment point at the midpoint of its travel, adjust the distance between the attachment points so that they are $\frac{1}{2}$ inch closer together than the distance at which the tubing assembly is taut.

(3) With the tubing assembly inside the environmental chamber, apply compressed air to the tubing assembly at a regulated pressure of 120 psi and maintain the supply of air to the tubing assembly for the duration of the test. Set the temperature of the environmental chamber to 220 degrees Fahrenheit (104 degrees Celsius) and initiate cycling of the movable attachment point. After 250,000 cycles, set the temperature of the environmental chamber to minus 40 degrees Fahrenheit (minus 40 degrees Celsius). After 500,000 cycles, set the temperature of

the environmental chamber to 220 degrees Fahrenheit (104 degrees Celsius). After 750,000 cycles, set the temperature of the environmental chamber to minus 40 degrees Fahrenheit (minus 40 degrees Celsius). Measure the air flow rate just prior to 1,000,000 cycles and if the compressed air flow rate supplied to the air brake tubing assembly exceeds 50 cubic centimeters per minute this constitutes failure of the test. Stop the cycling at 1,000,000 cycles and set the environmental chamber temperature to 75 degrees Fahrenheit (24 degrees Celsius), while air pressure is still supplied to the air brake tubing assembly. After one hour, measure the compressed air flow rate supplied to the air brake tubing assembly and if the rate exceeds 25 cubic centimeters per minute this constitutes failure of the test.

(4) For end fittings that use a threaded retaining nut, apply 20 percent of the original tightening torque as recorded in S12.21(b)(1). If the retention nut visibly moves, this constitutes a failure of the test.

S12.22 *End fitting retention test.* (a) Utilize an air brake tubing assembly or prepare a 12 inch length of tubing and install end fittings according to the end fitting manufacturer's instructions.

(b) Plug one end of the assembly, fill it with water, and connect the other end to a source of water pressure. Bleed any air from the assembly and water pressure system.

(c) Increase the pressure inside the tubing assembly at a rate of 3,000 psi per minute to 50 percent of the burst strength pressure for the size of tubing being tested as specified in Table VIII. Hold the pressure constant for 30 seconds.

(d) Increase the pressure inside the tubing assembly at a rate of 3,000 psi per minute to the burst strength pressure for the size of tubing being tested as specified in Table VIII.

S12.23 *Thermal conditioning and end fitting retention test—(a) Apparatus.* A source of hydraulic pressure that includes a pressure gauge or monitoring system, uses ASTM IRM 903 oil, and is constructed so that an air brake tubing

§571.107

assembly mounted to it can be conditioned in an environmental test chamber.

(b) *Preparation.* Utilize an air brake tubing assembly or prepare a 12 inch length of tubing and install end fittings according to the end fitting manufacturer's instructions. Attach one end of the assembly to the hydraulic pressure supply and plug the other end of the assembly, fill the assembly with ASTM IRM 903 oil and bleed any air from the assembly, and place the tubing assembly inside an environmental chamber. Conduct the following tests:

(1) With atmospheric pressure applied to the oil inside the tubing assembly, set the environmental chamber temperature to 200 degrees Fahrenheit (93 degrees Celsius) and condition the tubing assembly for 24 hours.

(2) With the temperature maintained at 200 degrees Fahrenheit (93 degrees Celsius), increase the oil pressure inside the tubing assembly at a rate of 3,000 psi per minute to 450 psi, and hold this pressure for 5 minutes.

(3) Decrease the oil pressure inside the tubing assembly at a rate of 3,000 psi per minute to atmospheric pressure and set the temperature of the environmental chamber to 75 degrees Fahrenheit (24 degrees Celsius). Condition the tubing assembly at this temperature for 1 hour.

(4) Set the temperature of the environmental chamber to minus 40 degrees Fahrenheit (minus 40 degrees Celsius) and condition the tubing assembly for 24 hours.

(5) With the temperature maintained at minus 40 degrees Fahrenheit (minus 40 degrees Celsius), increase the hydraulic pressure inside the tubing assembly at a rate of 3,000 psi per minute to 450 psi, and hold this pressure for 5 minutes.

S12.24 *End fitting serviceability—(a) Apparatus.* A source of air pressure that includes a pressure gauge or monitoring system and is equipped with a mass air flow meter.

(b) *Preparation.* Prepare a 12-inch length of tubing and plug one end. Assemble the end fitting with the threaded retention nut on the other end of the tubing according to the end fitting manufacturer's instructions, then disassemble the fitting. Repeat the assem-

49 CFR Ch. V (10–1–10 Edition)

bly and disassembly sequence three more times, and then reassemble the end fitting (five total assembly steps).

(c) Attach the end fitting with the threaded retention nut to the source of air pressure. Pressurize the tubing at a rate of 3,000 psi per minute to a pressure of 120 psi. If the end fitting leaks, measure and record the leakage rate using the mass air flow meter.

S12.25 *End fitting corrosion resistance.* Utilize an air brake tubing assembly or prepare a 12-inch length of tubing and install end fittings according to the end fitting manufacturer's instructions. Conduct the test specified in S6.11 using a plastic air brake tubing assembly.

S13. *Test Conditions.* Each hose assembly or appropriate part thereof shall be able to meet the requirements of S5, S7, S9, and S11, under the following conditions.

S13.1 The temperature of the testing room is 75 degrees Fahrenheit (24 degrees Celsius).

S13.2 The brake hoses and brake hose assemblies are at least 24 hours old, and unused.

S13.3 Specified test pressures are gauge pressures (psig).

[38 FR 31303, Nov. 13, 1973]

EDITORIAL NOTE: For FEDERAL REGISTER citations affecting §571.106, see the List of CFR Sections Affected, which appears in the Finding Aids section of the printed volume and on GPO Access.

§571.107 [Reserved]

§571.108, Nt. Standard No. 108; Lamps, reflective devices, and associated equipment.

S1. *Scope.* This standard specifies requirements for original and replacement lamps, reflective devices, and associated equipment.

S2. *Purpose.* The purpose of this standard is to reduce traffic accidents and deaths and injuries resulting from traffic accidents, by providing adequate illumination of the roadway, and by enhancing the conspicuity of motor vehicles on the public roads so that their presence is perceived and their signals understood, both in daylight and in darkness or other conditions of reduced visibility.