



# FEDERAL REGISTER

---

Vol. 87

Thursday

No. 23

February 3, 2022

Pages 6017–6402

OFFICE OF THE FEDERAL REGISTER



The **FEDERAL REGISTER** (ISSN 0097-6326) is published daily, Monday through Friday, except official holidays, by the Office of the Federal Register, National Archives and Records Administration, under the Federal Register Act (44 U.S.C. Ch. 15) and the regulations of the Administrative Committee of the Federal Register (1 CFR Ch. I). The Superintendent of Documents, U.S. Government Publishing Office, is the exclusive distributor of the official edition. Periodicals postage is paid at Washington, DC.

The **FEDERAL REGISTER** provides a uniform system for making available to the public regulations and legal notices issued by Federal agencies. These include Presidential proclamations and Executive Orders, Federal agency documents having general applicability and legal effect, documents required to be published by act of Congress, and other Federal agency documents of public interest.

Documents are on file for public inspection in the Office of the Federal Register the day before they are published, unless the issuing agency requests earlier filing. For a list of documents currently on file for public inspection, see [www.federalregister.gov](http://www.federalregister.gov).

The seal of the National Archives and Records Administration authenticates the **Federal Register** as the official serial publication established under the Federal Register Act. Under 44 U.S.C. 1507, the contents of the **Federal Register** shall be judicially noticed.

The **Federal Register** is published in paper and on 24x microfiche. It is also available online at no charge at [www.govinfo.gov](http://www.govinfo.gov), a service of the U.S. Government Publishing Office.

The online edition of the **Federal Register** is issued under the authority of the Administrative Committee of the Federal Register as the official legal equivalent of the paper and microfiche editions (44 U.S.C. 4101 and 1 CFR 5.10). It is updated by 6:00 a.m. each day the **Federal Register** is published and includes both text and graphics from Volume 1, 1 (March 14, 1936) forward. For more information, contact the GPO Customer Contact Center, U.S. Government Publishing Office. Phone 202-512-1800 or 866-512-1800 (toll free). E-mail, [gpocusthelp.com](mailto:gpocusthelp.com).

The annual subscription price for the **Federal Register** paper edition is \$860 plus postage, or \$929, for a combined **Federal Register**, **Federal Register** Index and List of CFR Sections Affected (LSA) subscription; the microfiche edition of the **Federal Register** including the **Federal Register** Index and LSA is \$330, plus postage. Six month subscriptions are available for one-half the annual rate. The prevailing postal rates will be applied to orders according to the delivery method requested. The price of a single copy of the daily **Federal Register**, including postage, is based on the number of pages: \$11 for an issue containing less than 200 pages; \$22 for an issue containing 200 to 400 pages; and \$33 for an issue containing more than 400 pages. Single issues of the microfiche edition may be purchased for \$3 per copy, including postage. Remit check or money order, made payable to the Superintendent of Documents, or charge to your GPO Deposit Account, VISA, MasterCard, American Express, or Discover. Mail to: U.S. Government Publishing Office—New Orders, P.O. Box 979050, St. Louis, MO 63197-9000; or call toll free 1-866-512-1800, DC area 202-512-1800; or go to the U.S. Government Online Bookstore site, see [bookstore.gpo.gov](http://bookstore.gpo.gov).

There are no restrictions on the republication of material appearing in the **Federal Register**.

**How To Cite This Publication:** Use the volume number and the page number. Example: 87 FR 12345.

**Postmaster:** Send address changes to the Superintendent of Documents, Federal Register, U.S. Government Publishing Office, Washington, DC 20402, along with the entire mailing label from the last issue received.

## SUBSCRIPTIONS AND COPIES

### PUBLIC

#### Subscriptions:

Paper or fiche	202-512-1800
Assistance with public subscriptions	202-512-1806

**General online information** 202-512-1530; 1-888-293-6498

#### Single copies/back copies:

Paper or fiche	202-512-1800
Assistance with public single copies	1-866-512-1800 (Toll-Free)

### FEDERAL AGENCIES

#### Subscriptions:

Assistance with Federal agency subscriptions:

Email	<a href="mailto:FRSubscriptions@nara.gov">FRSubscriptions@nara.gov</a>
Phone	202-741-6000

The Federal Register Printing Savings Act of 2017 (Pub. L. 115-120) placed restrictions on distribution of official printed copies of the daily **Federal Register** to members of Congress and Federal offices. Under this Act, the Director of the Government Publishing Office may not provide printed copies of the daily **Federal Register** unless a Member or other Federal office requests a specific issue or a subscription to the print edition. For more information on how to subscribe use the following website link: <https://www.gpo.gov/frsubs>.



# Contents

**Federal Register**

Vol. 87, No. 23

Thursday, February 3, 2022

## **Agriculture Department**

*See Foreign Agricultural Service*

*See Forest Service*

### **NOTICES**

Agency Information Collection Activities; Proposals, Submissions, and Approvals, 6131–6132

Meetings:

National Agricultural Research, Extension, Education, and Economics Advisory Board, 6131

## **Architectural and Transportation Barriers Compliance Board**

### **RULES**

Standards for Accessible Medical Diagnostic Equipment, 6037–6038

## **Centers for Medicare & Medicaid Services**

### **NOTICES**

Agency Information Collection Activities; Proposals, Submissions, and Approvals, 6175–6176

## **Children and Families Administration**

### **NOTICES**

Agency Information Collection Activities; Proposals, Submissions, and Approvals:  
Uniform Project Description, 6176–6177

## **Coast Guard**

### **RULES**

Safety Zone:

Coast Guard Sector Ohio Valley Annual and Recurring Safety Zones Update, 6031–6036

Special Local Regulation:

Sector Ohio Valley Annual and Recurring Special Local Regulations, Update, 6026–6031

## **Commerce Department**

*See Foreign-Trade Zones Board*

*See Industry and Security Bureau*

*See International Trade Administration*

*See National Oceanic and Atmospheric Administration*

## **Comptroller of the Currency**

### **NOTICES**

Agency Information Collection Activities; Proposals, Submissions, and Approvals:

Guidelines Establishing Standards for Recovery Planning by Certain Large Insured National Banks, Large Insured Federal Savings Associations, and Large Insured Federal Branches, 6238–6239

## **Consumer Product Safety Commission**

### **PROPOSED RULES**

Safety Standard for Clothing Storage Units, 6246–6322

### **NOTICES**

Settlement Agreement:

Core Health and Fitness, LLC, 6148–6151

## **Drug Enforcement Administration**

### **NOTICES**

Decision and Order:

Daniel R. Nevarre, MD, 6203

## **Education Department**

### **NOTICES**

Agency Information Collection Activities; Proposals, Submissions, and Approvals:

Application Forms and Instructions for the Fulbright-Hays Seminars Abroad Program, 6151–6152

Supplemental Support under the American Rescue Plan Application, 6154

Application Deadline:

Small, Rural School Achievement Program, 6152–6154

Applications for New Awards:

Supplemental Support under the American Rescue Plan, 6154–6160

Requests for Applications:

Proprietary Institution Grant Funds for Students Program under the Higher Education Emergency Relief Fund; American Rescue Plan Act, 6160–6161

## **Employment and Training Administration**

### **RULES**

Exercise of Time-Limited Authority to Increase the Fiscal Year 2022 Numerical Limitation for the H–2B

Temporary Nonagricultural Worker Program and

Portability Flexibility for H–2B Workers Seeking to

Change Employers, 6017

## **Energy Department**

*See Federal Energy Regulatory Commission*

## **Environmental Protection Agency**

### **RULES**

Tolerance Exemption:

Poly(oxy-1,2-ethanediyl)-a-hydro-w-hydroxy-, polymer with poly(isocyanatoalkyl) benzene, alkylol-blocked, 6039–6042

### **PROPOSED RULES**

Air Quality State Implementation Plans; Approvals and Promulgations:

Montana; 2015 Ozone National Ambient Air Quality Standards Interstate Transport Requirements, 6095–6100

Control of Air Pollution from Aircraft Engines:

Emission Standards and Test Procedures, 6324–6362

### **NOTICES**

Agency Information Collection Activities; Proposals, Submissions, and Approvals:

National Pollutant Discharge Elimination System Program; Renewal, 6170–6171

Meetings:

Local Government Advisory Committee, 6173

Pesticide Registration Review:

Draft Human Health and/or Ecological Risk Assessments for Several Pesticides, 6171–6173

Interim Decision; Correction, 6168–6169

Proposed Interim Decisions for Several Pesticides, 6169–6170

## **Federal Aviation Administration**

### **RULES**

Special Conditions:

Dassault Aviation Model Falcon 6X Airplane; Electronic-System Security Protection from Unauthorized External Access, 6017–6019

Standard Instrument Approach Procedures, and Takeoff Minimums and Obstacle Departure Procedures, 6019–6022

**PROPOSED RULES**

Airworthiness Directives:

- Bombardier, Inc. Airplanes, 6082–6086
- Leonardo S.p.a. Helicopters, 6091–6094
- Pilatus Aircraft Ltd. Airplanes, 6087–6089
- Piper Aircraft, Inc., Airplanes, 6089–6091

**NOTICES**

Agency Information Collection Activities; Proposals, Submissions, and Approvals:  
Proposed Construction or Alteration, Actual Construction or Alteration, 6228–6229  
Flight Path Management Advisory Circular, 6228

**Federal Communications Commission**

**RULES**

Television Broadcasting Services:  
Hazard, KY, 6043–6044

**PROPOSED RULES**

Television Broadcasting Services:  
Vernon, AL, 6100–6101

**Federal Emergency Management Agency**

**NOTICES**

Agency Information Collection Activities; Proposals, Submissions, and Approvals:  
Pandemic Personnel Facility Access, 6192–6193  
Disaster or Emergency Declaration and Related Determination:  
Alabama, 6193–6194  
Alabama; Amendment No. 1, 6190  
Arkansas, 6179  
California; Amendment No. 2, 6184  
California; Amendment No. 3, 6188  
Colorado, 6184  
Colorado; Amendment No. 8, 6182–6183  
Confederated Tribes of the Colville Reservation, 6182  
Illinois, 6191  
Kentucky, 6179–6182  
Kentucky; Amendment No. 1, 6185–6186  
Kentucky; Amendment No. 2, 6187–6189  
Kentucky; Amendment No. 3, 6194  
Kentucky; Amendment No. 4, 6190–6191  
Kentucky; Amendment No. 5, 6188  
Kentucky; Amendment No. 6, 6187  
Kentucky; Amendment No. 7, 6180  
Louisiana; Amendment No. 5, 6181  
Mississippi; Amendment No. 2, 6181, 6195  
Mississippi; Amendment No. 4, 6186  
Missouri, 6189–6190  
New Hampshire; Amendment No. 1, 6193  
North Carolina; Amendment No. 1, 6180–6181  
North Carolina; Amendment No. 14, 6180  
North Carolina; Amendment No. 2, 6184, 6186  
North Carolina; Amendment No. 4, 6185  
North Dakota; Amendment No. 8, 6189  
Tennessee, 6189  
Utah; Amendment No. 8, 6194–6195  
Washington, 6187  
Alaska; Amendment No. 2, 6185  
Montana; Amendment No. 8, 6191–6192  
South Dakota; Amendment No. 8, 6193  
Meetings:  
Technical Mapping Advisory Council, 6183–6184

**Federal Energy Regulatory Commission**

**NOTICES**

Application:  
Cameron LNG, LLC, 6163–6165  
Domtar Paper Co., LLC, 6161–6162  
Combined Filings, 6166–6168  
Environmental Assessments; Availability, etc.:  
Great River Hydro, LLC, 6167  
Texas Eastern Transmission, LP; Holbrook Compressor Units Replacement Project, 6165–6166  
Request under Blanket Authorization:  
Eastern Shore Natural Gas, 6162–6163

**Federal Maritime Commission**

**NOTICES**

Request for Comments:  
Investigation into Conditions Created by Canadian Ballast Water Regulations in the United States/Canada Great Lakes Trade, 6173–6175

**Federal Motor Carrier Safety Administration**

**RULES**

Commercial Driver's License Standards:  
Guidance Concerning Third Party Testers Conducting the Knowledge Test, 6045–6046

**NOTICES**

Exemption Application:  
Qualification of Drivers; Epilepsy and Seizure Disorders, 6231–6234  
Qualification of Drivers; Hearing, 6234–6236  
Qualification of Drivers; Vision, 6229–6231

**Federal Transit Administration**

**NOTICES**

Limitation on Claims Against Proposed Public Transportation Projects:  
TEXRail Extension Project and Richmond Highway Bus Rapid Transit Project, 6236–6237

**Fish and Wildlife Service**

**RULES**

Endangered and Threatened Species:  
Reclassification of Morro Shoulderband Snail, 6063–6077  
Removing San Benito Evening-Primrose (*Camissonia benitensis*), 6046–6063

**PROPOSED RULES**

Endangered and Threatened Species:  
Designation of Critical Habitat for Tiehm's Buckwheat, 6101–6118  
Reclassification of the Red-Cockaded Woodpecker, 6118–6130

**Foreign Agricultural Service**

**NOTICES**

Agency Information Collection Activities; Proposals, Submissions, and Approvals, 6132–6133

**Foreign Assets Control Office**

**NOTICES**

Sanctions Actions, 6239–6243

**Foreign-Trade Zones Board**

**NOTICES**

Approval of Subzone Status:  
Valbruna Stainless, Inc., Pompton Lakes, NJ, 6137

**Forest Service****NOTICES**

## Meetings:

- Dixie Resource Advisory Committee, 6134–6135
  - El Dorado County Resource Advisory Committee, 6133–6134
  - Yavapai Resource Advisory Committee, 6135
- Requests for Nominations:
- Collaborative Forest Landscape Restoration Advisory Panel, 6135–6136

**General Services Administration****RULES**

## Acquisition Regulations:

- References to Individuals with Disabilities, 6044–6045
- Federal Management Regulation; Personal Property; Multiple Repeal or Replace Regulatory Actions; Multiple Parts, 6042–6043

**Great Lakes St. Lawrence Seaway Development Corporation****NOTICES**

## Meetings:

- Advisory Board, 6237–6238

**Health and Human Services Department**

- See Centers for Medicare & Medicaid Services
- See Children and Families Administration
- See National Institutes of Health

**NOTICES**

## Meetings:

- Presidential Advisory Council on Combating Antibiotic-Resistant Bacteria, 6177

**Homeland Security Department**

See Coast Guard

See Federal Emergency Management Agency

**RULES**

- Exercise of Time-Limited Authority to Increase the Fiscal Year 2022 Numerical Limitation for the H–2B Temporary Nonagricultural Worker Program and Portability Flexibility for H–2B Workers Seeking to Change Employers, 6017

**NOTICES**

## Charter Establishment:

- Cyber Safety Review Board, 6195

**Housing and Urban Development Department****NOTICES**

- Allocations and Implementation of Consolidated Waivers and Alternative Requirements, 6364–6392

**Indian Affairs Bureau****NOTICES**

## Meetings:

- Advisory Board of Exceptional Children, 6196

**Industry and Security Bureau****RULES**

## Foreign-Direct Product Rules:

- Organization, Clarification, and Correction, 6022–6026

**Interior Department**

- See Fish and Wildlife Service
- See Indian Affairs Bureau
- See National Park Service
- See Reclamation Bureau

**International Trade Administration****NOTICES**

## Antidumping or Countervailing Duty Investigations, Orders, or Reviews:

- Certain Hardwood Plywood Products from the People's Republic of China, 6137–6139
- Certain Steel Nails from the Republic of Korea; Correction, 6140
- U.S. Section Member Appointments to the United States-Brazil CEO Forum, 6139–6140

**International Trade Commission****NOTICES**

## Complaint, 6201–6202

## Investigations; Determinations, Modifications, and Rulings, etc.:

- Certain Video Processing Devices, Components Thereof, and Digital Smart Televisions Containing the Same II, 6200–6201
- Uncoated Paper from Australia, Brazil, China, Indonesia, and Portugal, 6203

**Justice Department**

See Drug Enforcement Administration

**Labor Department**

- See Employment and Training Administration
- See Workers Compensation Programs Office

**National Aeronautics and Space Administration****NOTICES**

## Meetings:

- Advisory Council; Science, Technology, Engineering and Mathematics Engagement Committee, 6204

**National Credit Union Administration****PROPOSED RULES**

- Succession Planning, 6078–6082

**National Institutes of Health****NOTICES**

## Meetings:

- Center for Scientific Review, 6177–6178

**National Oceanic and Atmospheric Administration****NOTICES**

## Endangered and Threatened Species:

- 5-Year Review for North Atlantic Right Whale, 6146–6147

## Meetings:

- Caribbean Fishery Management Council, 6147–6148
- Fisheries of the Gulf of Mexico; Southeast Data, Assessment, and Review, 6145–6146
- Mid-Atlantic Fishery Management Council, 6140, 6146
- Pacific Fishery Management Council, 6144–6145
- Permits; Applications, Issuances, etc.:
  - Commercial Fishing Operations; Taking of Threatened or Endangered Marine Mammals, 6140–6144
- Takes of Marine Mammals Incidental to Specified Activities:
  - United States Navy Construction at Naval Station Newport, RI, 6145

**National Park Service****NOTICES**

- Privacy Act; Systems of Records, 6196–6199

**Nuclear Regulatory Commission****NOTICES**

Guide for Assessing, Monitoring, and Mitigating Aging Effects on Electrical Equipment Used in Nuclear Power Generating Stations, 6204–6205

**Postal Regulatory Commission****NOTICES**

New Postal Products, 6205–6206

**Presidential Documents****PROCLAMATIONS**

Special Observances:

- American Heart Month (Proc. 10336), 6393–6396
- National Black History Month (Proc. 10337), 6397–6399
- National Teen Dating Violence Awareness and Prevention Month (Proc. 10338), 6401–6402

**Railroad Retirement Board****PROPOSED RULES**

Consultative Examinations, 6094–6095

**Reclamation Bureau****NOTICES**

Agency Information Collection Activities; Proposals, Submissions, and Approvals:  
 Technical Service Center Summer Intern Program Application, 6200

Change in Discount Rate for Water Resources Planning, 6199–6200

**Securities and Exchange Commission****NOTICES**

Applications for Deregistration under the Investment Company Act, 6211–6212

Self-Regulatory Organizations; Proposed Rule Changes:  
 Cboe BZX Exchange, Inc., 6206–6211  
 NYSE American, LLC, 6212–6216  
 NYSE Arca, Inc., 6216–6218  
 The Nasdaq Stock Market, LLC, 6218–6223

**Small Business Administration****NOTICES**

Disaster Declaration:  
 Hawaii, 6223  
 Washington, 6223–6224

Major Disaster Declaration:  
 Washington, 6224

Military Reservist Economic Injury Disaster Loans:  
 Interest Rate for Second Quarter FY 2022, 6224

Surrender of License of Small Business Investment Company:  
 Eagle Fund II, LP, 6223

**State Department****NOTICES**

Culturally Significant Objects Imported for Exhibition:  
 Persia: Ancient Iran and the Classical World, 6227–6228

Privacy Act; Systems of Records, 6224–6227

Request for Membership Applications:  
 Defense Trade Advisory Group, 6227

**Transportation Department**

See Federal Aviation Administration  
 See Federal Motor Carrier Safety Administration  
 See Federal Transit Administration  
 See Great Lakes St. Lawrence Seaway Development Corporation

**Treasury Department**

See Comptroller of the Currency  
 See Foreign Assets Control Office

**U.S.-China Economic and Security Review Commission****NOTICES**

Meetings:  
 Public Hearing, 6243

**Veterans Affairs Department****RULES**

Extension of the Presumptive Period for Compensation for Gulf War Veterans, 6038–6039

**NOTICES**

Meetings:  
 Advisory Committee on the Readjustment of Veterans, 6243–6244

**Workers Compensation Programs Office****NOTICES**

Agency Information Collection Activities; Proposals, Submissions, and Approvals, 6203–6204

**Separate Parts In This Issue****Part II**

Consumer Product Safety Commission, 6246–6322

**Part III**

Environmental Protection Agency, 6324–6362

**Part IV**

Housing and Urban Development Department, 6364–6392

**Part V**

Presidential Documents, 6393–6399, 6401–6402

**Reader Aids**

Consult the Reader Aids section at the end of this issue for phone numbers, online resources, finding aids, and notice of recently enacted public laws.

To subscribe to the Federal Register Table of Contents electronic mailing list, go to <https://public.govdelivery.com/accounts/USGPOOFR/subscriber/new>, enter your e-mail address, then follow the instructions to join, leave, or manage your subscription.

**CFR PARTS AFFECTED IN THIS ISSUE**

A cumulative list of the parts affected this month can be found in the Reader Aids section at the end of this issue.

**3 CFR****Proclamations:**

10336.....6395  
10337.....6397  
10338.....6401

**8 CFR**

214.....6017  
274a.....6017

**12 CFR****Proposed Rules:**

701.....6078

**14 CFR**

25.....6017  
97 (2 documents) ...6019, 6021

**Proposed Rules:**

39 (4 documents) ...6082, 6087,  
6089, 6091

**15 CFR**

734.....6022  
736.....6022  
744.....6022  
774.....6022

**16 CFR****Proposed Rules:**

1112.....6246  
1261.....6246

**20 CFR**

655.....6017

**Proposed Rules:**

220.....6094

**33 CFR**

100.....6026  
165.....6031

**36 CFR**

1195.....6037

**38 CFR**

3.....6038

**40 CFR**

180.....6039

**Proposed Rules:**

52.....6095  
87.....6324  
1030.....6324  
1031.....6324

**41 CFR**

102-5.....6042  
102-37.....6042

**47 CFR**

73.....6043

**Proposed Rules:**

73.....6100

**48 CFR**

538.....6044  
552.....6044

**49 CFR**

383.....6045

**50 CFR**

17 (2 documents) ...6046, 6063

**Proposed Rules:**

17 (2 documents) ...6101, 6118

# Rules and Regulations

Federal Register

Vol. 87, No. 23

Thursday, February 3, 2022

This section of the FEDERAL REGISTER contains regulatory documents having general applicability and legal effect, most of which are keyed to and codified in the Code of Federal Regulations, which is published under 50 titles pursuant to 44 U.S.C. 1510.

The Code of Federal Regulations is sold by the Superintendent of Documents.

## DEPARTMENT OF HOMELAND SECURITY

### 8 CFR Parts 214 and 274a

[CIS No. 2708–21]

RIN 1615–AC77

## DEPARTMENT OF LABOR

### Employment and Training Administration

### 20 CFR Part 655

[DOL Docket No. ETA–2022–0001]

RIN 1205–AC09

### Exercise of Time-Limited Authority To Increase the Fiscal Year 2022 Numerical Limitation for the H–2B Temporary Nonagricultural Worker Program and Portability Flexibility for H–2B Workers Seeking To Change Employers

#### Correction

In rule document 2022–01866, appearing on pages 4722 through 4762 in the issue of Friday, January 28, 2022, make the following correction:

#### § 655.64 Special application filing and eligibility provisions for Fiscal Year 2022 under the January 28, 2022 supplemental cap increase. [Corrected]

■ On page 4761, in the second column, in the second paragraph, on the first line, “January 27, 2022” should read, “January 28, 2022”.

[FR Doc. C1–2022–01866 Filed 2–2–22; 8:45 am]

BILLING CODE 0099–10–D

## DEPARTMENT OF TRANSPORTATION

### Federal Aviation Administration

#### 14 CFR Part 25

[Docket No. FAA–2021–0897; Special Conditions No. 25–797–SC]

#### Special Conditions: Dassault Aviation Model Falcon 6X Airplane; Electronic System Security Protection From Unauthorized External Access

**AGENCY:** Federal Aviation Administration (FAA), DOT.

**ACTION:** Final special conditions; request for comments.

**SUMMARY:** These special conditions are issued for the Dassault Aviation (Dassault) Model Falcon 6X airplane. This airplane will have a novel or unusual design feature when compared to the state of technology envisioned in the airworthiness standards for transport-category airplanes. This design feature is the installation of an electronic network system architecture that allows connection to airplane electronic systems and networks, and access from airplane external sources (e.g., operator networks, wireless devices, internet connectivity, service provider satellite communications, electronic flight bags, etc.) to the previously isolated airplane electronic assets (networks, systems, and databases). The applicable airworthiness regulations do not contain adequate or appropriate safety standards for this design feature. These special conditions contain the additional safety standards that the Administrator considers necessary to establish a level of safety equivalent to that established by the existing airworthiness standards.

**DATES:** This action is effective on Dassault on February 3, 2022. Send comments on or before March 21, 2022.

**ADDRESSES:** Send comments identified by Docket No. FAA–2021–0897 using any of the following methods:

- *Federal eRegulations Portal:* Go to <https://www.regulations.gov/> and follow the online instructions for sending your comments electronically.

- *Mail:* Send comments to Docket Operations, M–30, U.S. Department of Transportation (DOT), 1200 New Jersey Avenue SE, Room W12–140, West Building Ground Floor, Washington, DC 20590–0001.

- *Hand Delivery or Courier:* Take comments to Docket Operations in Room W12–140 of the West Building Ground Floor at 1200 New Jersey Avenue SE, Washington, DC, between 9 a.m. and 5 p.m., Monday through Friday, except Federal holidays.

- *Fax:* Fax comments to Docket Operations at 202–493–2251.

*Privacy:* Except for Confidential Business Information (CBI) as described in the following paragraph, and other information as described in 14 CFR 11.35, the FAA will post all comments received without change to <https://www.regulations.gov/>, including any personal information you provide. The FAA will also post a report summarizing each substantive verbal contact received about these special conditions.

*Confidential Business Information:* Confidential Business Information (CBI) is commercial or financial information that is both customarily and actually treated as private by its owner. Under the Freedom of Information Act (FOIA) (5 U.S.C. 552), CBI is exempt from public disclosure. If your comments responsive to these special conditions, contain commercial or financial information that is customarily treated as private, that you actually treat as private, and that is relevant or responsive to these special conditions. Notice, it is important that you clearly designate the submitted comments as CBI. Please mark each page of your submission containing CBI as “PROPIN.” The FAA will treat such marked submissions as confidential under the FOIA, and the indicated comments will not be placed in the public docket of these special conditions. Send submissions containing CBI to the Information Contact below. Comments the FAA receives, which are not specifically designated as CBI, will be placed in the public docket for this rulemaking.

*Docket:* Background documents or comments received may be read at <https://www.regulations.gov/> at any time. Follow the online instructions for accessing the docket or go to Docket Operations in Room W12–140 of the West Building Ground Floor at 1200 New Jersey Avenue SE, Washington, DC, between 9 a.m. and 5 p.m., Monday through Friday, except Federal holidays.

**FOR FURTHER INFORMATION CONTACT:** Thuan T. Nguyen, Aircraft Information



Systems, AIR-622, Technical Innovation Policy Branch, Policy and Innovation Division, Aircraft Certification Service, Federal Aviation Administration, 2200 South 216th Street, Des Moines, Washington 98198; telephone and fax 206-231-3365; email [thuan.t.nguyen@faa.gov](mailto:thuan.t.nguyen@faa.gov).

**SUPPLEMENTARY INFORMATION:** The substance of these special conditions has been published in the **Federal Register** for public comment in several prior instances with no substantive comments received. Therefore, the FAA finds, pursuant to § 11.38(b), that new comments are unlikely, and notice and comment prior to this publication are unnecessary.

### Comments Invited

The FAA invites interested people to take part in this rulemaking by sending written comments, data, or views. The most helpful comments reference a specific portion of the special conditions, explain the reason for any recommended change, and include supporting data.

The FAA will consider all comments received by the closing date for comments. The FAA may change these special conditions based on the comments received.

### Background

On July 1, 2012, Dassault Aviation applied for a type certificate for their new Model Falcon 5X airplane. However, Dassault has decided not to release an airplane under the model designation Falcon 5X, instead choosing to change that model designation to Falcon 6X.

In February of 2018, due to engine supplier issues, Dassault extended the type certificate application date for their Model Falcon 5X airplane under new Model Falcon 6X. This airplane is a twin-engine business jet with seating for 19 passengers, and has a maximum takeoff weight of 77,460 pounds.

### Type Certification Basis

Under the provisions of title 14, Code of Federal Regulations (14 CFR) 21.17, Dassault must show that the Model Falcon 6X airplane meets the applicable provisions of part 25, as amended by amendments 25-1 through 25-146.

If the Administrator finds that the applicable airworthiness regulations (*e.g.*, 14 CFR part 25) do not contain adequate or appropriate safety standards for the Dassault Model Falcon 6X airplane because of a novel or unusual design feature, special conditions are prescribed under the provisions of § 21.16.

Special conditions are initially applicable to the model for which they are issued. Should the type certificate for that model be amended later to include any other model that incorporates the same novel or unusual design feature, these special conditions would also apply to the other model under § 21.101.

In addition to the applicable airworthiness regulations and special conditions, the Dassault Model Falcon 6X airplane must comply with the fuel-vent and exhaust-emission requirements of 14 CFR part 34, and the noise-certification requirements of 14 CFR part 36.

The FAA issues special conditions, as defined in 14 CFR 11.19, in accordance with § 11.38, and they become part of the type certification basis under § 21.17(a)(2).

### Novel or Unusual Design Features

The Dassault Model Falcon 6X airplane will incorporate the following novel or unusual design feature:

The installation of electronic network system architecture that allows access from airplane external sources (*e.g.*, operator networks, wireless devices, internet connectivity, service provider satellite communications, electronic flight bags, etc.) to the airplane's previously isolated electronic assets (networks, systems, and databases).

### Discussion

The Dassault Model Falcon 6X airplane architecture and network configuration is novel or unusual for commercial transport airplanes because it may allow increased connectivity to and access from external network sources, airline operations, and maintenance networks, to the airplane's control domain and airline information services domain. The airplane's control domain and airline information-services domain perform functions required for the safe operation and maintenance of the airplane. Previously, these domains had very limited connectivity with external network sources. This data network and design integration creates a potential for unauthorized persons to access the aircraft-control domain and airline information-services domain, and presents security vulnerabilities related to the introduction of computer viruses and worms, user errors, and intentional sabotage of airplane electronic assets (networks, systems, and databases) critical to the safety and maintenance of the airplane.

The existing FAA regulations did not anticipate these networked airplane-system architectures. Furthermore, these regulations and the current guidance

material do not address potential security vulnerabilities, which could be exploited by unauthorized access to airplane networks, data buses, and servers. Therefore, these special conditions ensure that the security (*i.e.*, confidentiality, integrity, and availability) of airplane systems is not compromised by unauthorized wired or wireless electronic connections. This includes ensuring that the security of the airplane's systems is not compromised during maintenance of the airplane's electronic systems. These special conditions also require the applicant to provide appropriate instructions to the operator to maintain all electronic-system safeguards that have been implemented as part of the original network design so that this feature does not allow or introduce security threats.

These special conditions contain the additional safety standards that the Administrator considers necessary to establish a level of safety equivalent to that established by the existing airworthiness standards.

### Applicability

As discussed above, these special conditions are applicable to the Dassault Model Falcon 6X airplane. Should Dassault apply at a later date for a change to the type certificate to include another model incorporating the same novel or unusual design feature, these special conditions would apply to that model as well.

### Conclusion

This action affects only a certain novel or unusual design feature on one model of airplane. It is not a rule of general applicability.

### List of Subjects in 14 CFR Part 25

Aircraft, Aviation safety, Reporting and recordkeeping requirements.

### Authority Citation

The authority citation for these special conditions is as follows:

**Authority:** 49 U.S.C. 106(f), 106(g), 40113, 44701, 44702, 44704.

### The Special Conditions

Accordingly, pursuant to the authority delegated to me by the Administrator, the following special conditions are issued as part of the type certification basis for the Dassault Model Falcon 6X airplane.

1. The applicant must ensure airplane electronic-system security protection from access by unauthorized sources external to the airplane, including those possibly caused by maintenance activity.

2. The applicant must ensure that electronic-system security threats are identified and assessed, and that effective electronic-system security-protection strategies are implemented to protect the airplane from all adverse impacts on safety, functionality, and continued airworthiness.

3. The applicant must establish appropriate procedures to allow the operator to ensure that continued airworthiness of the airplane is maintained, including all post-type-certification modifications that may have an impact on the approved electronic-system security safeguards.

Issued in Kansas City, Missouri, on January 28, 2022.

**Patrick R. Mullen,**

*Manager, Technical Innovation Policy Branch, Policy and Innovation Division, Aircraft Certification Service.*

[FR Doc. 2022-02145 Filed 2-2-22; 8:45 am]

BILLING CODE 4910-13-P

## DEPARTMENT OF TRANSPORTATION

### Federal Aviation Administration

#### 14 CFR Part 97

[Docket No. 31412; Amdt. No. 3994]

#### Standard Instrument Approach Procedures, and Takeoff Minimums and Obstacle Departure Procedures; Miscellaneous Amendments

**AGENCY:** Federal Aviation Administration (FAA), DOT.

**ACTION:** Final rule.

**SUMMARY:** This rule amends, suspends, or removes Standard Instrument Approach Procedures (SIAPs) and associated Takeoff Minimums and Obstacle Departure Procedures for operations at certain airports. These regulatory actions are needed because of the adoption of new or revised criteria, or because of changes occurring in the National Airspace System, such as the commissioning of new navigational facilities, adding new obstacles, or changing air traffic requirements. These changes are designed to provide for the safe and efficient use of the navigable airspace and to promote safe flight operations under instrument flight rules at the affected airports.

**DATES:** This rule is effective February 3, 2022. The compliance date for each SIAP, associated Takeoff Minimums, and ODP is specified in the amendatory provisions.

The incorporation by reference of certain publications listed in the regulations is approved by the Director

of the Federal Register as of February 3, 2022.

**ADDRESSES:** Availability of matter incorporated by reference in the amendment is as follows:

#### For Examination

1. U.S. Department of Transportation, Docket Ops-M30, 1200 New Jersey Avenue SE, West Bldg., Ground Floor, Washington, DC 20590-0001;

2. The FAA Air Traffic Organization Service Area in which the affected airport is located;

3. The office of Aeronautical Information Services, 6500 South MacArthur Blvd., Oklahoma City, OK 73169 or,

4. The National Archives and Records Administration (NARA).

For information on the availability of this material at NARA, email [fr.inspection@nara.gov](mailto:fr.inspection@nara.gov) or go to: <https://www.archives.gov/federal-register/cfr/ibr-locations.html>.

#### Availability

All SIAPs and Takeoff Minimums and ODPs are available online free of charge. Visit the National Flight Data Center online at [nfdc.faa.gov](http://nfdc.faa.gov) to register. Additionally, individual SIAP and Takeoff Minimums and ODP copies may be obtained from the FAA Air Traffic Organization Service Area in which the affected airport is located.

#### FOR FURTHER INFORMATION CONTACT:

Thomas J. Nichols, Flight Procedures and Airspace Group, Flight Technologies and Procedures Division, Flight Standards Service, Federal Aviation Administration. Mailing Address: FAA Mike Monroney Aeronautical Center, Flight Procedures and Airspace Group, 6500 South MacArthur Blvd., Registry Bldg. 29, Room 104, Oklahoma City, OK 73169. Telephone: (405) 954-4164.

**SUPPLEMENTARY INFORMATION:** This rule amends 14 CFR part 97 by amending the referenced SIAPs. The complete regulatory description of each SIAP is listed on the appropriate FAA Form 8260, as modified by the National Flight Data Center (NFDC)/Permanent Notice to Airmen (P-NOTAM), and is incorporated by reference under 5 U.S.C. 552(a), 1 CFR part 51, and 14 CFR 97.20. The large number of SIAPs, their complex nature, and the need for a special format make their verbatim publication in the **Federal Register** expensive and impractical. Further, airmen do not use the regulatory text of the SIAPs, but refer to their graphic depiction on charts printed by publishers of aeronautical materials. Thus, the advantages of incorporation

by reference are realized and publication of the complete description of each SIAP contained on FAA form documents is unnecessary. This amendment provides the affected CFR sections, and specifies the SIAPs and Takeoff Minimums and ODPs with their applicable effective dates. This amendment also identifies the airport and its location, the procedure and the amendment number.

#### Availability and Summary of Material Incorporated by Reference

The material incorporated by reference is publicly available as listed in the **ADDRESSES** section.

The material incorporated by reference describes SIAPs, Takeoff Minimums and ODPs as identified in the amendatory language for part 97 of this final rule.

#### The Rule

This amendment to 14 CFR part 97 is effective upon publication of each separate SIAP and Takeoff Minimums and ODP as amended in the transmittal. For safety and timeliness of change considerations, this amendment incorporates only specific changes contained for each SIAP and Takeoff Minimums and ODP as modified by FDC permanent NOTAMs.

The SIAPs and Takeoff Minimums and ODPs, as modified by FDC permanent NOTAM, and contained in this amendment are based on criteria contained in the U.S. Standard for Terminal Instrument Procedures (TERPS). In developing these changes to SIAPs and Takeoff Minimums and ODPs, the TERPS criteria were applied only to specific conditions existing at the affected airports. All SIAP amendments in this rule have been previously issued by the FAA in a FDC NOTAM as an emergency action of immediate flight safety relating directly to published aeronautical charts.

The circumstances that created the need for these SIAP and Takeoff Minimums and ODP amendments require making them effective in less than 30 days.

Because of the close and immediate relationship between these SIAPs, Takeoff Minimums and ODPs, and safety in air commerce, I find that notice and public procedure under 5 U.S.C. 553(b) are impracticable and contrary to the public interest and, where applicable, under 5 U.S.C. 553(d), good cause exists for making these SIAPs effective in less than 30 days.

The FAA has determined that this regulation only involves an established body of technical regulations for which frequent and routine amendments are

necessary to keep them operationally current. It, therefore—(1) is not a “significant regulatory action” under Executive Order 12866; (2) is not a “significant rule” under DOT regulatory Policies and Procedures (44 FR 11034; February 26, 1979); and (3) does not warrant preparation of a regulatory evaluation as the anticipated impact is so minimal. For the same reason, the FAA certifies that this amendment will not have a significant economic impact on a substantial number of small entities under the criteria of the Regulatory Flexibility Act.

**List of Subjects in 14 CFR Part 97**

Air traffic control, Airports, Incorporation by reference, Navigation (air).

Issued in Washington, DC, on January 21, 2022.

**Thomas J. Nichols,**

*Aviation Safety, Flight Standards Service, Manager, Standards Section, Flight Procedures & Airspace Group, Flight Technologies & Procedures Division.*

**Adoption of the Amendment**

Accordingly, pursuant to the authority delegated to me, Title 14, CFR part 97, (is amended by amending Standard Instrument Approach Procedures and Takeoff Minimums and ODPs, effective at 0901 UTC on the dates specified, as follows:

**PART 97—STANDARD INSTRUMENT APPROACH PROCEDURES**

■ 1. The authority citation for part 97 continues to read as follows:

**Authority:** 49 U.S.C. 106(f), 106(g), 40103, 40106, 40113, 40114, 40120, 44502, 44514, 44701, 44719, 44721–44722.

■ 2. Part 97 is amended to read as follows:

By amending: § 97.23 VOR, VOR/DME, VOR or TACAN, and VOR/DME or TACAN; § 97.25 LOC, LOC/DME, LDA, LDA/DME, SDF, SDF/DME; § 97.27 NDB, NDB/DME; § 97.29 ILS, ILS/DME, MLS, MLS/DME, MLS/RNAV; § 97.31 RADAR SIAPs; § 97.33 RNAV SIAPs; and § 97.35 COPTER SIAPs, Identified as follows:

\* \* \* *Effective Upon Publication*

AIRAC Date	State	City	Airport	FDC No.	FDC Date	Subject
24-Feb-22	KS	Norton	Norton Muni	1/1415	1/12/22	NDB RWY 16, Amdt 2A.
24-Feb-22	PA	Punxsutawney	Punxsutawney Muni	1/1640	1/12/22	RNAV (GPS) RWY 24, Orig-B.
24-Feb-22	AL	Oneonta	Robbins Fld	1/1661	1/12/22	RNAV (GPS) RWY 6, Orig-C.
24-Feb-22	IL	Taylorville	Taylorville Muni	1/2014	1/12/22	RNAV (GPS) RWY 18, Orig-A.
24-Feb-22	IL	Taylorville	Taylorville Muni	1/2015	1/12/22	RNAV (GPS) RWY 36, Orig.
24-Feb-22	SC	Cheraw	Cheraw Muni/Lynch Bellinger Fld.	1/3793	1/12/22	RNAV (GPS) RWY 8, Orig-B.
24-Feb-22	FL	Milton	Peter Prince Fld	1/9396	1/12/22	RNAV (GPS) RWY 36, Amdt 1C.
24-Feb-22	GA	Atlanta	Hartsfield—Jackson Atlanta Intl.	2/1922	1/7/22	ILS OR LOC RWY 10, Amdt 5.
24-Feb-22	WI	La Pointe	Major Gilbert Fld	2/3229	1/12/22	RNAV (GPS) RWY 4, Orig-B.
24-Feb-22	PA	Allentown	Allentown Queen City Muni.	2/3231	1/12/22	RNAV (GPS) RWY 7, Amdt 1F.
24-Feb-22	OK	Goldsby	David Jay Perry	2/3234	1/12/22	RNAV (GPS) RWY 31, Orig-A.
24-Feb-22	GA	Nahunta	Brantley County	2/3236	1/12/22	RNAV (GPS) Y RWY 1, Orig-A.
24-Feb-22	GA	Nahunta	Brantley County	2/3237	1/12/22	RNAV (GPS) Y RWY 19, Orig-A.
24-Feb-22	IA	Pella	Pella Muni	2/3240	1/12/22	RNAV (GPS) RWY 16, Amdt 1.
24-Feb-22	IA	Pella	Pella Muni	2/3241	1/12/22	RNAV (GPS) RWY 34, Amdt 1.
24-Feb-22	TX	Crockett	Houston County	2/3244	1/12/22	RNAV (GPS) RWY 2, Orig-B.
24-Feb-22	TX	Marfa	Marfa Muni	2/3373	1/12/22	RNAV (GPS) RWY 31, Orig-A.
24-Feb-22	MO	Osage Beach	Grand Glaize—Osage Beach.	2/3385	1/12/22	VOR RWY 32, Amdt 6B.
24-Feb-22	MO	Osage Beach	Grand Glaize—Osage Beach.	2/3386	1/12/22	RNAV (GPS) RWY 14, Amdt 1B.
24-Feb-22	MO	Osage Beach	Grand Glaize—Osage Beach.	2/3387	1/12/22	RNAV (GPS) RWY 32, Amdt 1B.
24-Feb-22	MO	St Charles	St Charles County Smartt.	2/3388	1/12/22	RNAV (GPS) RWY 18, Orig.
24-Feb-22	MO	St Charles	St Charles County Smartt.	2/3389	1/12/22	VOR RWY 18, Amdt 1.
24-Feb-22	IA	Forest City	Forest City Muni	2/3395	1/12/22	RNAV (GPS) RWY 15, Orig-B.
24-Feb-22	IA	Forest City	Forest City Muni	2/3396	1/12/22	RNAV (GPS) RWY 33, Orig-B.
24-Feb-22	IL	Freeport	Albertus	2/3397	1/12/22	ILS OR LOC RWY 24, Orig-B.
24-Feb-22	IL	Freeport	Albertus	2/3398	1/12/22	RNAV (GPS) RWY 24, Amdt 1B.
24-Feb-22	IL	Freeport	Albertus	2/3399	1/12/22	RNAV (GPS) RWY 6, Orig-A.
24-Feb-22	LA	Jonesboro	Jonesboro	2/3405	1/12/22	RNAV (GPS) RWY 18, Orig-B.
24-Feb-22	LA	Jonesboro	Jonesboro	2/3406	1/12/22	RNAV (GPS) RWY 36, Orig-B.
24-Feb-22	MI	Houghton Lake	Roscommon County—Blodgett Meml.	2/3407	1/12/22	RNAV (GPS) RWY 9, Amdt 2D.
24-Feb-22	MI	Houghton Lake	Roscommon County—Blodgett Meml.	2/3408	1/12/22	RNAV (GPS) RWY 27, Amdt 1C.
24-Feb-22	TX	Marfa	Marfa Muni	2/3413	1/12/22	VOR RWY 31, Amdt 6A.
24-Feb-22	CA	Santa Maria	Santa Maria Pub/Capt G Allan Hancock Fld.	2/3430	1/12/22	ILS OR LOC RWY 12, Amdt 10A.
24-Feb-22	CA	Santa Maria	Santa Maria Pub/Capt G Allan Hancock Fld.	2/3431	1/12/22	RNAV (GPS) RWY 12, Amdt 1C.
24-Feb-22	CA	Santa Maria	Santa Maria Pub/Capt G Allan Hancock Fld.	2/3432	1/12/22	VOR RWY 12, Amdt 15A.

AIRAC Date	State	City	Airport	FDC No.	FDC Date	Subject
24-Feb-22 .....	CA	Santa Maria .....	Santa Maria Pub/Capt G Allan Hancock Fld.	2/3433	1/12/22	LOC/DME BC-A, Amdt 10E.

[FR Doc. 2022-02136 Filed 2-2-22; 8:45 am]

BILLING CODE 4910-13-P

## DEPARTMENT OF TRANSPORTATION

### Federal Aviation Administration

#### 14 CFR Part 97

[Docket No. 31411; Amdt. No. 3993]

#### Standard Instrument Approach Procedures, and Takeoff Minimums and Obstacle Departure Procedures; Miscellaneous Amendments

**AGENCY:** Federal Aviation Administration (FAA), DOT.

**ACTION:** Final rule.

**SUMMARY:** This rule establishes, amends, suspends, or removes Standard Instrument Approach Procedures (SIAPs) and associated Takeoff Minimums and Obstacle Departure Procedures (ODPs) for operations at certain airports. These regulatory actions are needed because of the adoption of new or revised criteria, or because of changes occurring in the National Airspace System, such as the commissioning of new navigational facilities, adding new obstacles, or changing air traffic requirements. These changes are designed to provide safe and efficient use of the navigable airspace and to promote safe flight operations under instrument flight rules at the affected airports.

**DATES:** This rule is effective February 3, 2022. The compliance date for each SIAP, associated Takeoff Minimums, and ODP is specified in the amendatory provisions.

The incorporation by reference of certain publications listed in the regulations is approved by the Director of the Federal Register as of February 3, 2022.

**ADDRESSES:** Availability of matters incorporated by reference in the amendment is as follows:

#### For Examination

1. U.S. Department of Transportation, Docket Ops-M30, 1200 New Jersey Avenue SE, West Bldg., Ground Floor, Washington, DC 20590-0001.

2. The FAA Air Traffic Organization Service Area in which the affected airport is located;

3. The office of Aeronautical Information Services, 6500 South

MacArthur Blvd., Oklahoma City, OK 73169 or,

4. The National Archives and Records Administration (NARA). For information on the availability of this material at NARA, email [fr.inspection@nara.gov](mailto:fr.inspection@nara.gov) or go to: <https://www.archives.gov/federal-register/cfr/ibr-locations.html>.

#### Availability

All SIAPs and Takeoff Minimums and ODPs are available online free of charge. Visit the National Flight Data Center at [nfdc.faa.gov](http://nfdc.faa.gov) to register. Additionally, individual SIAP and Takeoff Minimums and ODP copies may be obtained from the FAA Air Traffic Organization Service Area in which the affected airport is located.

#### FOR FURTHER INFORMATION CONTACT:

Thomas J. Nichols, Flight Procedures and Airspace Group, Flight Technologies and Procedures Division, Flight Standards Service, Federal Aviation Administration. Mailing Address: FAA Mike Monroney Aeronautical Center, Flight Procedures and Airspace Group, 6500 South MacArthur Blvd., Registry Bldg. 29, Room 104, Oklahoma City, OK 73169. Telephone (405) 954-4164.

**SUPPLEMENTARY INFORMATION:** This rule amends 14 CFR part 97 by establishing, amending, suspending, or removes SIAPs, Takeoff Minimums and/or ODPs. The complete regulatory description of each SIAP and its associated Takeoff Minimums or ODP for an identified airport is listed on FAA form documents which are incorporated by reference in this amendment under 5 U.S.C. 552(a), 1 CFR part 51, and 14 CFR part 97.20. The applicable FAA Forms 8260-3, 8260-4, 8260-5, 8260-15A, 8260-15B, when required by an entry on 8260-15A, and 8260-15C.

The large number of SIAPs, Takeoff Minimums and ODPs, their complex nature, and the need for a special format make publication in the **Federal Register** expensive and impractical. Further, airmen do not use the regulatory text of the SIAPs, Takeoff Minimums or ODPs, but instead refer to their graphic depiction on charts printed by publishers or aeronautical materials. Thus, the advantages of incorporation by reference are realized and publication of the complete description of each SIAP, Takeoff Minimums and ODP listed on FAA form

documents is unnecessary. This amendment provides the affected CFR sections and specifies the typed of SIAPs, Takeoff Minimums and ODPs with their applicable effective dates. This amendment also identifies the airport and its location, the procedure, and the amendment number.

#### Availability and Summary of Material Incorporated by Reference

The material incorporated by reference is publicly available as listed in the **ADDRESSES** section.

The material incorporated by reference describes SIAPs, Takeoff Minimums and/or ODPs as identified in the amendatory language for part 97 of this final rule.

#### The Rule

This amendment to 14 CFR part 97 is effective upon publication of each separate SIAP, Takeoff Minimums and ODP as amended in the transmittal. Some SIAP and Takeoff Minimums and textual ODP amendments may have been issued previously by the FAA in a Flight Data Center (FDC) Notice to Airmen (NOTAM) as an emergency action of immediate flights safety relating directly to published aeronautical charts.

The circumstances that created the need for some SIAP and Takeoff Minimums and ODP amendments may require making them effective in less than 30 days. For the remaining SIAPs and Takeoff Minimums and ODPs, an effective date at least 30 days after publication is provided.

Further, the SIAPs and Takeoff Minimums and ODPs contained in this amendment are based on the criteria contained in the U.S. Standard for Terminal Instrument Procedures (TERPS). In developing these SIAPs and Takeoff Minimums and ODPs, the TERPS criteria were applied to the conditions existing or anticipated at the affected airports. Because of the close and immediate relationship between these SIAPs, Takeoff Minimums and ODPs, and safety in air commerce, I find that notice and public procedure under 5 U.S.C. 553(b) are impracticable and contrary to the public interest and, where applicable, under 5 U.S.C. 553(d), good cause exists for making some SIAPs effective in less than 30 days.

The FAA has determined that this regulation only involves an established body of technical regulations for which

frequent and routine amendments are necessary to keep them operationally current. It, therefore—(1) is not a “significant regulatory action” under Executive Order 12866; (2) is not a “significant rule” under DOT Regulatory Policies and Procedures (44 FR 11034; February 26, 1979); and (3) does not warrant preparation of a regulatory evaluation as the anticipated impact is so minimal. For the same reason, the FAA certifies that this amendment will not have a significant economic impact on a substantial number of small entities under the criteria of the Regulatory Flexibility Act.

#### Lists of Subjects in 14 CFR Part 97;

Air Traffic Control, Airports, Incorporation by reference, Navigation (Air).

Issued in Washington, DC, on January 21, 2022.

**Thomas J. Nichols,**

*Aviation Safety, Flight Standards Service, Manager, Standards Section, Flight Procedures & Airspace Group, Flight Technologies & Procedures Division.*

#### Adoption of the Amendment

Accordingly, pursuant to the authority delegated to me, Title 14, Code of Federal Regulations, Part 97 (14 CFR part 97) is amended by establishing, amending, suspending, or removing Standard Instrument Approach Procedures and/or Takeoff Minimums and Obstacle Departure Procedures effective at 0901 UTC on the dates specified, as follows:

#### PART 97—STANDARD INSTRUMENT APPROACH PROCEDURES

■ 1. The authority citation for part 97 continues to read as follows:

**Authority:** 49 U.S.C. 106(f), 106(g), 40103, 40106, 40113, 40114, 40120, 44502, 44514, 44701, 44719, 44721–44722.

■ 2. Part 97 is amended to read as follows:

#### Effective 24 March 2022

Siloam Springs, AR, KSLG, RNAV (GPS) RWY 18, Amdt 2  
 Prescott, AZ, KPRC, VOR RWY 12, Amdt 3  
 Fresno, CA, KFCH, RNAV (GPS) RWY 12, Amdt 1A  
 Hanford, CA, KHJO, VOR–A, Amdt 10, CANCELLED  
 Napa, CA, KAPC, RNAV (GPS) RWY 6, Amdt 3  
 Napa, CA, KAPC, VOR RWY 6, Amdt 15  
 Ontario, CA, KONT, RNAV (RNP) Z RWY 26L, Amdt 3  
 Ontario, CA, KONT, RNAV (RNP) Z RWY 26R, Amdt 3  
 Ontario, CA, Ontario International Airport, Takeoff Minimums and Obstacle DP, Amdt 9A

Rio Vista, CA, O88, RNAV (GPS) RWY 25, Amdt 4  
 Salinas, CA, KSNS, RNAV (GPS) RWY 8, Orig  
 Tulare, CA, KTLR, VOR RWY 13, Amdt 2A, CANCELLED  
 Alamosa, CO, KALS, ILS OR LOC RWY 2, Amdt 3  
 Alamosa, CO, KALS, RNAV (GPS) RWY 2, Amdt 2  
 Alamosa, CO, KALS, RNAV (GPS) RWY 20, Amdt 2  
 Alamosa, CO, KALS, VOR–B, Amdt 6  
 Fort Collins/Loveland, CO, KFNL, ILS OR LOC RWY 33, Amdt 7  
 Fort Collins/Loveland, CO, KFNL, RNAV (GPS) RWY 15, Orig-C  
 Fort Collins/Loveland, CO, KFNL, RNAV (GPS) RWY 33, Amdt 2  
 Donalsonville, GA, 17J, RNAV (GPS) RWY 1, Amdt 2  
 Donalsonville, GA, 17J, RNAV (GPS) RWY 19, Amdt 2  
 Wellington, KS, KEGT, VOR RWY 18, Amdt 3, CANCELLED  
 Falmouth, MA, 5B6, RNAV (GPS) RWY 7, Orig  
 Falmouth, MA, 5B6, RNAV (GPS) RWY 25, Orig  
 Falmouth, MA, Falmouth Airpark, Takeoff Minimums and Obstacle DP, Orig  
 Coldwater, MI, KOEB, VOR RWY 7, Amdt 5B, CANCELLED  
 Coldwater, MI, KOEB, VOR/DME RWY 25, Orig-B, CANCELLED  
 Detroit, MI, KDET, RNAV (GPS) RWY 15, Orig-D  
 Bowling Green, MO, H19, RNAV (GPS) RWY 13, Amdt 1  
 Bowling Green, MO, H19, RNAV (GPS) RWY 31, Amdt 1  
 Bowling Green, MO, Bowling Green Muni, Takeoff Minimums and Obstacle DP, Amdt 1  
 Keene, NH, KEEN, ILS OR LOC RWY 2, Amdt 6  
 Saranac Lake, NY, KSLK, RNAV (GPS) RWY 23, Amdt 2  
 Columbus, OH, KCMH, RNAV (RNP) Z RWY 28L, Amdt 2A  
 Albany, OR, S12, VOR–A, Amdt 5  
 Elizabethton, TN, 0A9, RNAV (GPS) RWY 6, Amdt 1  
 Decatur, TX, KLUD, RNAV (GPS) RWY 35, Orig-C

[FR Doc. 2022–02137 Filed 2–2–22; 8:45 am]

**BILLING CODE 4910–13–P**

## DEPARTMENT OF COMMERCE

### Bureau of Industry and Security

#### 15 CFR Parts 734, 736, 744, and 774

[Docket No. 220127–0035]

RIN 0694–AI61

#### Foreign-Direct Product Rules: Organization, Clarification, and Correction

**AGENCY:** Bureau of Industry and Security, Department of Commerce.

**ACTION:** Final rule.

**SUMMARY:** The Bureau of Industry and Security (BIS) is clarifying, reorganizing, and making minor corrections to the provisions of the foreign-direct product (FDP) rules. Before this final rule, the FDP rules appeared in parts 736 and 744 of the Export Administration Regulations (EAR); now, the rules are consolidated in part 734 of the EAR. These revisions clarify the applicability of the FDP rules and make one correction applicable to the FDP rules as to the term “U.S.-origin technology and software.”

**DATES:** The effective date of this rule is February 3, 2022.

**FOR FURTHER INFORMATION CONTACT:** Sharron Cook, 202–482–2440, *Sharron.Cook@bis.doc.gov*.

#### SUPPLEMENTARY INFORMATION:

#### Consolidation and Organization of the Foreign-Direct Product (FDP) Rules

This final rule consolidates the FDP rules in § 734.9 of the Export Administration Regulations (EAR). Before publication of this rule, the FDP rules were found in § 736.2(b)(3) (General Prohibition 3) and footnote 1 to supplement no. 4 to part 744 (the Entity List). Placing the FDP rules in part 734 (Scope of the EAR) clarifies that they are used to determine if a foreign-produced item is subject to, and thus within the scope of, the EAR. To further clarify the FDP rules, this rule moves the license requirement, license review policy, and license exception applicability text for listed entities from the Entity List’s footnote 1 to supplement no. 4 to part 744 to § 744.11(a), where the overall license requirements pertaining to listed entities are located.

#### Organization of the FDP Rules

In new § 734.9, this rule separates the FDP provisions into four paragraphs: The National Security FDP rule, the 9x515 FDP rule, the “600 series” FDP rule, and the Entity List FDP rule. While the product scope of the first three FDP rules is relatively similar in format, the country scopes of each rule are different. This reorganization and naming of the FDP rules does not make substantive changes to the FDP rules. Rather, it facilitates reference to and compliance with the rules.

The original national security-focused FDP rule is now the National Security FDP rule. The provisions of the 9x515 FDP rule and the “600 series” FDP rule are reorganized into separate paragraphs with a description of the product scope followed by the country scope. The provisions of the Entity List FDP rule are organized with a description of the

product scope followed by the applicable end-user scope.

This rule moves a definition of the term ‘major component’ from a note to footnote 1 to Supplement no. 4 to part 744 of the EAR to a new definition paragraph in § 734.9(a) of the EAR. In making this change, this rule clarifies that the definition of the term ‘major component’ applies to all the FDP rules, and not just the Entity List FDP rule. A ‘major component’ of a plant located outside the United States for all FDP rules is “equipment” that is essential to the “production” of an item, including testing “equipment.” As noted in the August 20, 2020, final rule that amended the Entity List FDP rule (see 85 FR 51596, at 51601), any equipment that is involved in any of the production stages is considered *essential*. As a conforming edit, to indicate that the term is defined in that section, BIS added single quotation marks around the term ‘major component’ wherever it appears in § 734.9.

#### Clarification of the FDP Rules

This rule further clarifies the FDP rules by adding double quotation marks around terms that are defined in part 772 of the EAR, *e.g.*, direct product, technology, software, and equipment. BIS has received requests for additional guidance about determining the scope of production equipment in relation to the Entity List FDP rule and clarifying that these are defined terms should help the public better understand its obligations.

In addition, this rule clarifies in § 736.2(b)(3) of the EAR (General Prohibition Three), that foreign-direct products subject to the EAR are not necessarily subject to a license requirement and that license requirements must be determined based on an assessment of the classification, destination, end user, and end use of the items.

Lastly, this rule clarifies the circumstances under which the “600 series” FDP rule applies to items described in Export Control Classification Number (ECCN) 0A919. The text of ECCN 0A919 states that it includes the foreign direct product of “600 series” technology or software. However, before this rule, the text of General Prohibition Three did not explicitly include ECCN 0A919 items when describing other aspects of determining applicability of the “600 series” FDP rule. This rule also replaces the cross reference in ECCN 0A919.a.3 as a conforming edit.

#### Correction: U.S.-Origin “technology” and “software”

In this rule, BIS corrects an earlier revision to General Prohibition Three to clarify when the FDP rules are intended to apply to the direct product of U.S.-origin technology or software. On May 19, 2020, BIS published a rule entitled “Export Administration Regulations: Amendments to General Prohibition Three (Foreign-Direct Product Rule) and the Entity List” (85 FR 29849). This rule removed the word “U.S.” from the heading of § 736.2(b)(3) (Foreign-Direct Product rule) where it had been placed in front of the words “technology and software.” This revision was made because the scope of the heading did not align with the scope of the Entity List foreign-direct product rule being added to the EAR on that date. The Entity List FDP rule in § 734.9(e), and as it previously appeared in footnote 1 to supplement no. 4 to part 744 of the EAR, applies to the FDP of technology or software that is subject to the EAR, but that is not necessarily technology or software of U.S. origin. The preamble of the May 19 rule that added the Entity List FDP rule clearly stated that BIS did not intend to change the scope of the other FDP rules, noting General Prohibition Three: “continues to apply to foreign-produced items controlled for national security reasons, 9x515 items, or “600 series” items and has three criteria: The reason for control or classification of the U.S. “technology” or “software”; the foreign-produced item’s reason for control or classification; and the destination country of the foreign-produced item[.]” The May 19 rule stated that it “maintains the scope and criteria of General Prohibition Three[.]” Nevertheless, by removing the term “U.S.” from General Prohibition Three’s heading, BIS may have inadvertently caused confusion as to whether the revision was intended to change the product scope of all FDP rules, because the term “U.S.” had only been in the heading and not in the other FDP rules’ product scope descriptions. For this reason, this rule clarifies the EAR by specifically stating in each of the FDP rules that the application of the rule relates to U.S.-origin technology or software.

#### Export Control Reform Act of 2018

On August 13, 2018, the President signed into law the John S. McCain National Defense Authorization Act for Fiscal Year 2019, which included ECRA (codified, as amended, at 50 U.S.C. Sections 4801–4852). ECRA provides the legal basis for BIS’s principal

authorities and serves as the authority under which BIS issues this rule.

#### Rulemaking Requirements

1. Executive Orders 13563 and 12866 direct agencies to assess all costs and benefits of available regulatory alternatives and, if regulation is necessary, to select regulatory approaches that maximize net benefits (including potential economic, environmental, public health and safety effects and distributive impacts and equity). Executive Order 13563 emphasizes the importance of quantifying both costs and benefits and of reducing costs, harmonizing rules, and promoting flexibility.

This final rule has not been designated a “significant regulatory action” under Executive Order 12866. This rule does not contain policies with Federalism implications as that term is defined under Executive Order 13132.

2. Notwithstanding any other provision of law, no person is required to respond to, nor shall any person be subject to a penalty for failure to comply with, a collection of information subject to the requirements of the Paperwork Reduction Act of 1995 (44 U.S.C. 3501 *et seq.*) (PRA), unless that collection of information displays a currently valid Office of Management and Budget (OMB) Control Number. This final rule does not intentionally affect any PRA collection burden, because this intent of this final rule is to organize, clarify, and correct the rules pertaining to the foreign direct product and in doing so BIS only expects minimal, if any, change to the burden hours associated with license requirements. The following is a list of the Paperwork Reduction Act of 1995 (44 U.S.C. 3501 *et seq.*) (PRA) collection approvals that may be encountered if a license is required, and the estimated average burden hours for each:

- 0694–0088, “Simplified Network Application Processing System,” and carries a burden-hour estimate of 29.6 minutes for a manual or electronic submission;
- 0694–0137 “License Exceptions and Exclusions,” which carries a burden-hour estimate average of 1.5 hours per submission (Note: Submissions for License Exceptions are rarely required);
- 0694–0096 “Five Year Records Retention Period,” which carries a burden-hour estimate of less than 1 minute; and
- 0607–0152 “Automated Export System (AES) Program,” which carries a burden-hour estimate of 3 minutes per electronic submission.

Any comments regarding these collections of information, including

suggestions for reducing the burden, may be submitted online at <https://www.reginfo.gov/public/do/PRAMain>. Find the particular information collection by using the search function and entering either the title of the collection or the OMB Control Number.

3. Pursuant to Section 1762 of the Export Control Reform Act of 2018 (ECRA) (50 U.S.C. 4821), this action is exempt from the Administrative Procedure Act (APA) (5 U.S.C. 553) requirements for notice of proposed rulemaking, opportunity for public participation and delay in effective date.

### List of Subjects

#### 15 CFR Part 734

Administrative practice and procedure, Exports, Inventions and patents, Research, Science and technology.

#### 15 CFR Part 736

Exports.

#### 15 CFR Part 744

Exports, Reporting and recordkeeping requirements, Terrorism.

#### 15 CFR Part 774

Exports, Reporting and recordkeeping requirements, Terrorism.

For the reasons discussed in the preamble, the Bureau of Industry and Security of the Department of Commerce amends 15 CFR parts 734, 736, 744, and 774 as follows:

### PART 734—SCOPE OF THE EXPORT ADMINISTRATION REGULATIONS

■ 1. The authority citation for part 734 is revised to read as follows:

**Authority:** 50 U.S.C. 4801–4852; 50 U.S.C. 4601 *et seq.*; 50 U.S.C. 1701 *et seq.*; E.O. 12938, 59 FR 59099, 3 CFR, 1994 Comp., p. 950; E.O. 13020, 61 FR 54079, 3 CFR, 1996 Comp., p. 219; E.O. 13026, 61 FR 58767, 3 CFR, 1996 Comp., p. 228; E.O. 13222, 66 FR 44025, 3 CFR, 2001 Comp., p. 783; E.O. 13637, 78 FR 16129, 3 CFR, 2014 Comp., p. 223; Notice of November 10, 2021, 86 FR 62891 (November 12, 2021).

■ 2. Add § 734.9 to read as follows:

#### § 734.9 Foreign-Direct Product (FDP) Rules.

Foreign-produced items located outside the United States are subject to the EAR when they are a “direct product” of specified “technology” or “software,” or are produced by a plant or ‘major component’ of a plant that itself is a “direct product” of specified “technology” or “software.” If a foreign-produced item is subject to the EAR, then you should separately determine the license requirements that apply to

that foreign-produced item (e.g., by assessing the item classification, destination, end-use, and end-user in the relevant transaction). Not all transactions involving foreign-produced items that are subject to the EAR require a license. Those transactions that do require a license may be eligible for a license exception.

(a) *Definitions.* The terms defined in this paragraph are specific to § 734.9 of the EAR. These terms are indicated by single quotation marks. Terms that are in double quotation marks are defined in part 772 of the EAR.

*Major Component:* A major component of a plant located outside the United States means “equipment” that is essential to the “production” of an item, including testing “equipment.”

(b) *National Security FDP rule.* A foreign-produced item is subject to the EAR if it meets both the product scope in paragraph (b)(1) of this section and the country scope in paragraph (b)(2) of this section.

(1) *Product scope of National Security FDP rule.* The product scope applies if a foreign-produced item meets the conditions of either paragraph (b)(1)(i) or (ii) of this section.

(i) “*Direct product*” of “*technology*” or “*software*.” A foreign-produced item meets the product scope of this paragraph if it meets both of the following conditions:

(A) The foreign-produced item is the “direct product” of U.S.-origin “technology” or “software” that requires a written assurance as a supporting document for a license, as defined in paragraph (o)(3)(i) of supplement no. 2 to part 748 of the EAR, or as a precondition for the use of License Exception TSR at § 740.6 of the EAR; and

(B) The foreign-produced item is subject to national security controls as designated in the applicable ECCN of the Commerce Control List at part 774 of the EAR.

(ii) “*Direct product*” of a complete plant or ‘major component’ of a plant. A foreign-produced item meets the product scope of this paragraph if it meets both of the following conditions:

(A) The foreign-produced item is a “direct product” of a complete plant or ‘major component’ of a plant that itself is the “direct product” of U.S.-origin “technology” that requires a written assurance as a supporting document for a license or as a precondition for the use of License Exception TSR in § 740.6 of the EAR; and

(B) The foreign-produced item is subject to national security controls as designated on the applicable ECCN of

the Commerce Control List at part 774 of the EAR.

(2) *Country scope of National Security FDP rule.* A foreign-produced item meets the country scope of this paragraph if its destination is listed in Country Group D:1, E:1, or E:2 (See supplement no.1 to part 740 of the EAR).

(c) *9x515 FDP rule.* A foreign-produced item is subject to the EAR if it meets both the product scope in paragraph (c)(1) of this section and the country scope in paragraph (c)(2) of this section.

(1) *Product scope of 9x515 FDP rule.* The product scope applies if a foreign-produced item meets the conditions of either paragraph (c)(1)(i) or (ii) of this section.

(i) “*Direct product*” of “*technology*” or “*software*.” A foreign-produced item meets the product scope of this paragraph if it meets both of the following conditions:

(A) The foreign-produced item is the “direct product” of U.S.-origin “technology” or “software” that is specified in ECCN 9D515 or 9E515; and

(B) The foreign-produced item is specified in a 9x515 ECCN.

(ii) “*Direct product*” of a complete plant or ‘major component’ of a plant. A foreign-produced item meets the product scope of this paragraph if it meets both of the following conditions:

(A) The foreign-produced item is a “direct product” of a complete plant or any ‘major component’ of a plant that itself is the “direct product” of U.S.-origin “technology” specified in ECCN 9E515; and

(B) The foreign-produced item is specified in a 9x515 ECCN.

(2) *Country scope of 9x515 FDP rule.* A foreign produced item meets the country scope of this paragraph if its destination is listed in Country Group D:5, E:1, or E:2 (see supplement no. 1 to part 740 of the EAR).

(d) “*600 series*” FDP rule. A foreign-produced item is subject to the EAR if it meets both the product scope in paragraph (d)(1) of this section and the country scope in paragraph (d)(2) of this section.

**NOTE 1 TO PARAGRAPH (D) INTRODUCTORY TEXT:** As described in the CCL, ECCN 0A919 is included in this paragraph because it includes the “direct product” of “600 series” “technology” or “software”.

(1) *Product scope of “600 series” FDP rule.* The product scope applies if a foreign-produced item meets the conditions of either paragraph (d)(1)(i) or (ii) of this section.

(i) “*Direct product*” of “*technology*” or “*software*.” A foreign-produced item

meets the product scope of this paragraph if it meets both of the following conditions:

(A) The foreign-produced item is the “direct product” of U.S.-origin “technology” or “software” that is specified in a “600 series” ECCN; and

(B) The foreign-produced item is specified in a “600 series” ECCN or ECCN 0A919.

(ii) “*Direct product*” of a complete plant or ‘major component’ of a plant. Foreign-produced items meet the product scope of this paragraph if they meet both of the following conditions:

(A) The foreign-produced item is the “direct product” of a complete plant or ‘major component’ of a plant that itself is the “direct product” of U.S.-origin “technology” that is specified in a “600 series” ECCN; and

(B) The foreign produced item is specified in a “600 series” ECCN.

(2) *Country scope of “600 series” FDP rule.* A foreign-produced item meets the country scope of this paragraph if it is destined to a country listed in Country Group D:1, D:3, D:4, D:5, E:1, or E:2 (see supplement no.1 to part 740 of the EAR).

(e) *Entity List FDP rule.* A foreign-produced item is subject to the EAR if it meets both the product scope in paragraph (e)(1) of this section and the end-user scope in paragraph (e)(2) of this section. See § 744.11(a) of the EAR for license requirements, license review policy, and license exceptions applicable to foreign-produced items that are subject to the EAR pursuant to this paragraph.

(1) *Product Scope of Entity List FDP rule.* The product scope applies if a foreign-produced item meets the conditions of either paragraph (e)(1)(i) or (ii) of this section.

(i) “*Direct product*” of “*technology*” or “*software*.” A foreign-produced item meets the product scope of this paragraph if the foreign-produced item is a “direct product” of “technology” or “software” subject to the EAR and specified in ECCN 3D001, 3D991, 3E001, 3E002, 3E003, 3E991, 4D001, 4D993, 4D994, 4E001, 4E992, 4E993, 5D001, 5D991, 5E001, or 5E991 of the Commerce Control List (CCL) in supplement no. 1 to part 774 of the EAR; or

(ii) “*Direct product*” of a complete plant or ‘major component’ of a plant. A foreign-produced item meets the product scope of this paragraph if the foreign-produced item is produced by any plant or ‘major component’ of a plant that is located outside the United States, when the plant or ‘major component’ of a plant, whether made in the U.S. or a foreign country, itself is a

“direct product” of “technology” or “software” subject to the EAR that is specified in ECCN 3D001, 3D991, 3E001, 3E002, 3E003, 3E991, 4D001, 4D993, 4D994, 4E001, 4E992, 4E993, 5D001, 5D991, 5E001, or 5E991 of the CCL.

**NOTE 2 TO PARAGRAPH (E)(1):** A foreign-produced item includes any foreign-produced wafer whether finished or unfinished.

(2) *End-user scope of the Entity List FDP rule.* A foreign-produced item meets the end-user scope of this paragraph if there is “knowledge” that:

(i) *Activities involving Footnote 1 designated entities.* The foreign-produced item will be incorporated into, or will be used in the “production” or “development” of any “part,” “component,” or “equipment” produced, purchased, or ordered by any entity with a footnote 1 designation in the license requirement column of the Entity List in Supplement No. 4 to part 744 of the EAR; or

(ii) *Footnote 1 designated entities as transaction parties.* Any entity with a footnote 1 designation in the license requirement column of the Entity List in Supplement No. 4 to part 744 of the EAR is a party to any transaction involving the foreign-produced item, e.g., as a “purchaser,” “intermediate consignee,” “ultimate consignee,” or “end-user.”

## PART 736—GENERAL PROHIBITIONS

■ 3. The authority citation for part 736 continues to read as follows:

**Authority:** 50 U.S.C. 4801–4852; 50 U.S.C. 4601 *et seq.*; 50 U.S.C. 1701 *et seq.*; E.O. 12938, 59 FR 59099, 3 CFR, 1994 Comp., p. 950; E.O. 13020, 61 FR 54079, 3 CFR, 1996 Comp., p. 219; E.O. 13026, 61 FR 58767, 3 CFR, 1996 Comp., p. 228; E.O. 13222, 66 FR 44025, 3 CFR, 2001 Comp., p. 783; E.O. 13338, 69 FR 26751, 3 CFR, 2004 Comp., p. 168; Notice of November 10, 2021, 86 FR 62891 (November 12, 2021); Notice of May 6, 2021, 86 FR 26793 (May 10, 2021).

■ 4. Section 736.2 is amended by revising paragraph (b)(3) to read as follows:

### § 736.2 General prohibitions and determination of applicability.

\* \* \* \* \*

(b) \* \* \*

(3) *General Prohibition Three—Foreign-direct product (FDP) rules—(i)* You may not, without a license or license exception, export from abroad, reexport, or transfer (in-country) foreign-“direct products” subject to the EAR pursuant to § 734.9 if such items are subject to a license requirement in part 736, 742, 744, 746, or 764 of the EAR.

(ii) Each license exception described in part 740 of the EAR supersedes General Prohibition Three if all terms and conditions of a given license exception are met and none of the restrictions of § 740.2 or 744.11(a) apply.

## PART 744—CONTROL POLICY: END-USER AND END-USER BASED

■ 5. The authority citation for part 744 continues to read as follows:

**Authority:** 50 U.S.C. 4801–4852; 50 U.S.C. 4601 *et seq.*; 50 U.S.C. 1701 *et seq.*; 22 U.S.C. 3201 *et seq.*; 42 U.S.C. 2139a; 22 U.S.C. 7201 *et seq.*; 22 U.S.C. 7210; E.O. 12058, 43 FR 20947, 3 CFR, 1978 Comp., p. 179; E.O. 12851, 58 FR 33181, 3 CFR, 1993 Comp., p. 608; E.O. 12938, 59 FR 59099, 3 CFR, 1994 Comp., p. 950; E.O. 13026, 61 FR 58767, 3 CFR, 1996 Comp., p. 228; E.O. 13099, 63 FR 45167, 3 CFR, 1998 Comp., p. 208; E.O. 13222, 66 FR 44025, 3 CFR, 2001 Comp., p. 783; E.O. 13224, 66 FR 49079, 3 CFR, 2001 Comp., p. 786; Notice of September 15, 2021, 86 FR 52069 (September 17, 2021); Notice of November 10, 2021, 86 FR 62891 (November 12, 2021).

■ 6. Section 744.11 is amended by revising paragraph (a) to read as follows:

### § 744.11 License requirements that apply to entities acting contrary to the national security or foreign policy interests of the United States.

\* \* \* \* \*

(a) *License requirement, availability of license exceptions, and license application review policy.* (1) A license is required, to the extent specified on the Entity List, to export, reexport, or transfer (in-country) any item subject to the EAR when an entity that is listed on the Entity List is a party to the transaction as described in § 748.5(c) through (f). License exceptions may not be used unless authorized in the Entity List entry for the entity that is party to the transaction. Applications for licenses required by this section will be evaluated as stated in the Entity List entry for the entity that is party to the transaction, in addition to any other applicable review policy stated elsewhere in the EAR.

(2) *Entity List Foreign-Direct Product (FDP) license requirements, review policy, and license exceptions.* You may not, without a license or license exception, reexport, export from abroad, or transfer (in-country) any foreign-produced item subject to the EAR pursuant to § 734.9(e) of the EAR to any end user described in § 734.9(e)(2) of the EAR. All license exceptions described in part 740 of the EAR are available for foreign-produced items that are subject to this license requirement if all terms and conditions of the applicable license



exception are met and the restrictions in § 740.2 do not apply. The sophistication and capabilities of technology in items is a factor in license application review; license applications for foreign-produced items subject to a license requirement by this paragraph (a)(2) that are capable of supporting the “development” or “production” of telecom systems, equipment and devices below the 5G level (e.g., 4G, 3G) will be reviewed on a case-by-case basis.

\* \* \* \* \*

■ 7. Supplement No. 4 to part 744 is amended by:

■ a. Removing the phrase “see §§ 736.2(b)(3)(vi),<sup>1</sup>” wherever it appears and adding in its place “see § 734.9(e),<sup>1</sup>”; and

■ b. Revising footnote 1.

The revision reads as follows:

**Supplement No. 4 to Part 744—Entity List**

\* \* \* \* \*

<sup>1</sup> For this entity, see § 734.9(e) of the EAR for foreign-produced items that are subject to the EAR and § 744.11 of the EAR for related license requirements, license review policy, and applicable license exceptions.

\* \* \* \* \*

**PART 774—THE COMMERCE CONTROL LIST**

■ 8. The authority citation for part 774 continues to read as follows:

**Authority:** 50 U.S.C. 4801–4852; 50 U.S.C. 4601 *et seq.*; 50 U.S.C. 1701 *et seq.*; 10 U.S.C. 8720; 10 U.S.C. 8730(e); 22 U.S.C. 287c, 22 U.S.C. 3201 *et seq.*; 22 U.S.C. 6004; 42 U.S.C. 2139a; 15 U.S.C. 1824; 50 U.S.C. 4305; 22 U.S.C. 7201 *et seq.*; 22 U.S.C. 7210; E.O. 13026, 61 FR 58767, 3 CFR, 1996 Comp., p. 228; E.O. 13222, 66 FR 44025, 3 CFR, 2001 Comp., p. 783.

■ 9. In supplement no. 1 to part 774, Category 0, ECCN 0A919 is revised to read as follows:

**Supplement No. 1 to Part 774—The Commerce Control List**

\* \* \* \* \*

**0A919 “Military commodities” located and produced outside the United States as follows (see list of items controlled)**

**License Requirements**

*Reasons for Control:* RS, AT

*Country Chart (see Supp. No. 1 to part 738)*

Control(s)	Country Chart (see Supp. No. 1 to part 738)
RS applies to entire entry.	RS Column 1, See § 742.6(a)(3) for license requirements.
AT applies to entire entry.	AT Column 1.

**List Based License Exceptions (See Part 740 for a description of all license exceptions)**

LVS: N/A

GBS: N/A

**List of Items Controlled**

*Related Controls:* (1) “Military commodities” are subject to the export licensing jurisdiction of the Department of State if they incorporate items that are subject to the International Traffic in Arms Regulations (ITAR) (22 CFR parts 120–130). (2) “Military commodities” described in this paragraph are subject to the export licensing jurisdiction of the Department of State if such commodities are described on the U.S. Munitions List (22 CFR part 121) and are in the United States. (3) The furnishing of assistance (including training) to foreign persons, whether in the United States or abroad, in the design, development, engineering, manufacture, production, assembly, testing, repair, maintenance, modification, operation, demilitarization, destruction, processing, or use of defense articles that are subject to the ITAR; or the furnishing to foreign persons of any technical data controlled under 22 CFR 121.1 whether in the United States or abroad are under the licensing jurisdiction of the Department of State. (4) Brokering activities (as defined in 22 CFR 129) of “military commodities” that are subject to the ITAR are under the licensing jurisdiction of the Department of State.

*Related Definitions:* “Military commodity” or “military commodities” means an article, material or supply that is described on the U.S. Munitions List (22 CFR part 121) or on the Munitions List that is published by the Wassenaar Arrangement on Export Controls for Conventional Arms and Dual-Use Goods and Technologies (*i.e.*, the Wassenaar Arrangement Munitions List (WAML)), but does not include software, technology, any item listed in any ECCN for which the last three numerals are 018, or any item in the “600 series.”

*Items:*

a. “Military commodities” produced and located outside the United States that are not subject to the International Traffic in Arms Regulations (22 CFR parts 120–130) and having any of the following characteristics:

a.1. Incorporate more than a *de minimis* amount of U.S.-origin controlled content classified under ECCNs 6A002, 6A003, or 6A993.a (having a maximum frame rate equal to or less than 9 Hz and thus meeting the criterion of Note 3.a to 6A003.b.4);

a.2. Incorporate more than a *de minimis* amount of U.S.-origin “600 series” controlled content (see § 734.4 of the EAR); or

a.3. Are direct products of U.S.-origin “600 series” technology or software (see § 734.9(d) of the EAR).

b. [Reserved]

\* \* \* \* \*

**Thea D. Rozman Kendler,**  
*Assistant Secretary for Export Administration.*

[FR Doc. 2022–02302 Filed 2–2–22; 8:45 am]

**BILLING CODE 3510–33–P**

**DEPARTMENT OF HOMELAND SECURITY**

**Coast Guard**

**33 CFR Part 100**

[Docket Number USCG–2021–0873]

RIN 1625–AA08

**Special Local Regulations; Sector Ohio Valley Annual and Recurring Special Local Regulations, Update**

**AGENCY:** Coast Guard, DHS.

**ACTION:** Final rule.

**SUMMARY:** The Coast Guard is amending and updating its special local regulations for recurring marine parades, regattas, and other events that take place in the Coast Guard Sector Ohio Valley area of responsibility (AOR). This rule informs the public of regularly scheduled events that require additional safety measures through the establishing of a special local regulation. Through this rulemaking the current list of recurring special local regulations is updated with revisions, additional events, and removal of events that no longer take place in Sector Ohio Valley’s AOR. When these special local regulations are enforced, certain restrictions are placed on marine traffic in specified areas.

**DATES:** This rule is effective February 3, 2022.

**ADDRESSES:** To view documents mentioned in this preamble as being available in the docket, go to <https://www.regulations.gov>, type USCG–2021–0873 in the “SEARCH” box and click “SEARCH.” Click on Open Docket Folder on the line associated with this rule.

**FOR FURTHER INFORMATION CONTACT:** If you have questions on this rule, call or email Petty Officer Christopher Roble, Sector Ohio Valley, U.S. Coast Guard; telephone (502) 779–5336, email [SECOHV-WWM@uscg.mil](mailto:SECOHV-WWM@uscg.mil).

**SUPPLEMENTARY INFORMATION:**

**I. Table of Abbreviations**

CFR Code of Federal Regulations  
COTP Captain of the Port Sector Ohio Valley  
DHS Department of Homeland Security  
E.O. Executive order  
FR Federal Register  
NPRM Notice of proposed rulemaking  
§ Section  
U.S.C. United States Code

**II. Background Information and Regulatory History**

The Captain of the Port Sector Ohio Valley (COTP) is establishing,

amending, and updating its current list of recurring special local regulations codified under 33 CFR 100.801 in Table no. 1, for the COTP Ohio Valley zone.

On December 8th, 2021, the Coast Guard published a notice of proposed rulemaking (NPRM) titled Sector Ohio Valley Annual and Recurring Special Local Regulations Update (86 FR 69602). There we stated why we issued the NPRM, and invited comments on our proposed regulatory action related to those recurring regulated areas. During the comment period that ended January 7th, 2022, no comments were received.

### III. Legal Authority and Need for Rule

The Coast Guard is issuing this rule under authority in 46 U.S.C. 70034 (previously 33 U.S.C. 1231). The Coast Guard is amending and updating the special local regulations under 33 CFR part 100 to include the most up to date list of recurring special local regulations for events held on or around navigable waters within the Sector Ohio Valley AOR. These events include marine parades, boat races, swim events, and others. The current list under 33 CFR 100.801 requires amending to provide new information on existing special local regulations, include new special local regulations expected to recur annually or biannually, and to remove special local regulations that are no longer required. Issuing individual regulations for each new special local regulation, amendment, or removal of an existing special local regulation creates unnecessary administrative costs and burdens. This rulemaking reduces administrative overhead and provides the public with notice through publication in the **Federal Register** of the upcoming recurring special local regulations.

### IV. Discussion of Comments, Changes, and the Rule

As noted above, we received no comments on our NPRM published December 8th, 2021. There is one change in the regulatory text of this rule from the proposed rule in the NPRM. The event Thunder Over Louisville will occur the 4th weekend of April this year. The text now reads in the table: 2 days—Third or fourth Friday and Saturday in April.

### V. Regulatory Analyses

We developed this rule after considering numerous statutes and Executive orders related to rulemaking. Below we summarize our analyses based on a number of these statutes and Executive orders, and we discuss First Amendment rights of protestors.

#### A. Regulatory Planning and Review

Executive Orders 12866 and 13563 direct agencies to assess the costs and benefits of available regulatory alternatives and, if regulation is necessary, to select regulatory approaches that maximize net benefits. This rule has not been designated a “significant regulatory action,” under Executive Order 12866. Accordingly, this rule has not been reviewed by the Office of Management and Budget (OMB).

The Coast Guard expects the economic impact of this rule to be minimal, and therefore a full regulatory evaluation is unnecessary. This rule establishes special local regulations limiting access to certain areas under 33 CFR 100 within Sector Ohio Valley’s AOR. The effect of this rulemaking will not be significant because these special local regulations are limited in scope and duration. Deviation from the special local regulations established through this rulemaking may be requested from the appropriate COTP and requests will be considered on a case-by-case basis. Broadcast Notices to Mariners and Local Notices to Mariners will inform the community of these special local regulations so that they may plan accordingly for these short restrictions on transit. Vessel traffic may request permission from the COTP Ohio Valley or a designated representative to enter the restricted areas.

#### B. Impact on Small Entities

The Regulatory Flexibility Act of 1980, 5 U.S.C. 601–612, as amended, requires Federal agencies to consider the potential impact of regulations on small entities during rulemaking. The term “small entities” comprises small businesses, not-for-profit organizations that are independently owned and operated and are not dominant in their fields, and governmental jurisdictions with populations of less than 50,000. The Coast Guard received no comments from the Small Business Administration on this rulemaking. The Coast Guard certifies under 5 U.S.C. 605(b) that this rule will not have a significant economic impact on a substantial number of small entities.

While some owners or operators of vessels intending to transit the safety zone may be small entities, for the reasons stated in section V.A above, this rule will not have a significant economic impact on any vessel owner or operator.

Under section 213(a) of the Small Business Regulatory Enforcement Fairness Act of 1996 (Pub. L. 104–121), we want to assist small entities in

understanding this rule. If the rule would affect your small business, organization, or governmental jurisdiction and you have questions concerning its provisions or options for compliance, please call or email the person listed in the **FOR FURTHER INFORMATION CONTACT** section.

Small businesses may send comments on the actions of Federal employees who enforce, or otherwise determine compliance with, Federal regulations to the Small Business and Agriculture Regulatory Enforcement Ombudsman and the Regional Small Business Regulatory Fairness Boards. The Ombudsman evaluates these actions annually and rates each agency’s responsiveness to small business. If you wish to comment on actions by employees of the Coast Guard, call 1–888–REG–FAIR (1–888–734–3247). The Coast Guard will not retaliate against small entities that question or complain about this rule or any policy or action of the Coast Guard.

#### C. Collection of Information

This rule will not call for a new collection of information under the Paperwork Reduction Act of 1995 (44 U.S.C. 3501–3520).

#### D. Federalism and Indian Tribal Governments

A rule has implications for federalism under Executive Order 13132, Federalism, if it has a substantial direct effect on the States, on the relationship between the National Government and the States, or on the distribution of power and responsibilities among the various levels of government. We have analyzed this rule under that Order and have determined that it is consistent with the fundamental federalism principles and preemption requirements described in Executive Order 13132.

Also, this rule does not have tribal implications under Executive Order 13175, Consultation and Coordination with Indian Tribal Governments, because it does not have a substantial direct effect on one or more Indian tribes, on the relationship between the Federal Government and Indian tribes, or on the distribution of power and responsibilities between the Federal Government and Indian tribes.

#### E. Unfunded Mandates Reform Act

The Unfunded Mandates Reform Act of 1995 (2 U.S.C. 1531–1538) requires Federal agencies to assess the effects of their discretionary regulatory actions. In particular, the Act addresses actions that may result in the expenditure by a State, local, or tribal government, in the aggregate, or by the private sector of

\$100,000,000 (adjusted for inflation) or more in any one year. Though this rule will not result in such an expenditure, we do discuss the effects of this rule elsewhere in this preamble.

*F. Environment*

We have analyzed this rule under Department of Homeland Security Directive 023–01, Rev. 1, associated implementing instructions, and Environmental Planning COMDTINST 5090.1 (series), which guide the Coast Guard in complying with the National Environmental Policy Act of 1969 (42 U.S.C. 4321–4370f), and have determined that this action is one of a category of actions that do not individually or cumulatively have a significant effect on the human environment. This rule involves the establishment of special local

regulations related to marine event permits for marine parades, regattas, and other marine events. It is categorically excluded from further review under paragraph L(61) of Appendix A, Table 1 of DHS Instruction Manual 023–01–001–01, Rev. 1.

*G. Protest Activities*

The Coast Guard respects the First Amendment rights of protesters. Protesters are asked to call or email the person listed in the **FOR FURTHER INFORMATION CONTACT** section to coordinate protest activities so that your message can be received without jeopardizing the safety or security of people, places or vessels.

**List of Subjects in 33 CFR Part 100**

Marine safety, Navigation (water), Reporting and recordkeeping requirements, and Waterways.

For the reasons discussed in the preamble, the U.S. Coast Guard amends 33 CFR part 100 as follows:

**PART 100—SAFETY OF LIFE ON NAVIGABLE WATERS**

- 1. The authority citation for part 100 continues to read as follows:

**Authority:** 46 U.S.C. 70041; 33 CFR 1.05–1.

- 2. In § 100.801, revise Table 1 to read as follows:

**§ 100.801 Annual Marine Events in the Eighth Coast Guard District.**

\* \* \* \* \*

TABLE 1 TO § 100.801—SECTOR OHIO VALLEY ANNUAL AND RECURRING MARINE EVENTS

Date	Event/sponsor	Ohio valley location	Regulated area
1. 3 days—Second or third weekend in March.	Oak Ridge Rowing Association/ Cardinal Invitational.	Oak Ridge, TN .....	Clinch River, Mile 48.5–52.0 (Tennessee).
2. 1 day—Third weekend in March	Vanderbilt Rowing/Vanderbilt Invite.	Nashville, TN .....	Cumberland River, Mile 188.0–192.7 (Tennessee).
3. 2 days—Fourth weekend in March.	Oak Ridge Rowing Association/ Atomic City Turn and Burn.	Oak Ridge, TN .....	Clinch River, Mile 48.5–52.0 (Tennessee).
4. 3 days—One weekend in April	Big 10 Invitational Regatta .....	Oak Ridge, TN .....	Clinch River, Mile 48.5–52.0 (Tennessee).
5. 1 day—One weekend in April ...	Lindamood Cup .....	Marietta, OH .....	Muskingum River, Mile 0.5–1.5 (Ohio).
6. 3 days—Third weekend in April	Oak Ridge Rowing Association/ SIRA Regatta.	Oak Ridge, TN .....	Clinch River, Mile 48.5–52.0 (Tennessee).
7. 2 days—Third or fourth Friday and Saturday in April.	Thunder Over Louisville .....	Louisville, KY .....	Ohio River, Mile 597.0–604.0 (Kentucky).
8. 1 day—During the last week of April or first week of May.	Great Steamboat Race .....	Louisville, KY .....	Ohio River, Mile 595.0–605.3 (Kentucky).
9. 3 days—Fourth weekend in April.	Oak Ridge Rowing Association/ Dogwood Junior Regatta.	Oak Ridge, TN .....	Clinch River, Mile 48.5–52.0 (Tennessee).
10. 3 Days in May .....	U.S. Rowing Southeast Youth Championship Regatta.	Oak Ridge, TN .....	Clinch River, Mile 48.5–52 (Tennessee).
11. 3 days—Second weekend in May.	Vanderbilt Rowing/ACRA Henley	Nashville, TN .....	Cumberland River, Mile 188.0–194.0 (Tennessee).
12. 3 days—Second weekend in May.	Oak Ridge Rowing Association/ Big 12 Championships.	Oak Ridge, TN .....	Clinch River, Mile 48.5–52.0 (Tennessee).
13. 3 days—Third weekend in May.	Oak Ridge Rowing Association/ Dogwood Masters.	Oak Ridge, TN .....	Clinch River, Mile 48.5–52.0 (Tennessee).
14. 1 day—Third weekend in May	World Triathlon Corporation/ IRONMAN 70.3.	Chattanooga, TN .....	Tennessee River, Mile 462.7–467.5 (Tennessee).
15. 1 day—During the last weekend in May or on Memorial Day.	Mayor’s Hike, Bike and Paddle ....	Louisville, KY .....	Ohio River, Mile 601.0–604.5 (Kentucky).
16. 1 day—The last week in May	Chickamauga Dam Swim .....	Chattanooga, TN .....	Tennessee River, Mile 470.0–473.0 (Tennessee).
17. 2 days—Last weekend in May or first weekend in June.	Visit Knoxville/Racing on the Tennessee.	Knoxville, TN .....	Tennessee River, Mile 647.0–648.0 (Tennessee).
18. 2 days—Last weekend in May or one weekend in June.	Outdoor Chattanooga/Chattanooga Swim Festival.	Chattanooga, TN .....	Tennessee River, Mile 454.0–468.0 (Tennessee).
19. 2 days—First weekend of June.	Thunder on the Bay/KDBA .....	Pisgah Bay, KY .....	Tennessee River, Mile 30.0 (Kentucky).
20. 1 day—First weekend in June	Visit Knoxville/Knoxville Powerboat Classic.	Knoxville, TN .....	Tennessee River, Mile 646.4–649.0 (Tennessee).
21. 1 day—One weekend in June	Tri-Louisville .....	Louisville, KY .....	Ohio River, Mile 600.5–604.0 (Kentucky).
22. 2 days—One weekend in June	New Martinsville Vintage Regatta	New Martinsville, WV .....	Ohio River Mile 127.5–128.5 (West Virginia).
23. 3 days—One of the last three weekends in June.	Lawrenceburg Regatta/Whiskey City Regatta.	Lawrenceburg, IN .....	Ohio River, Mile 491.0–497.0 (Indiana).

TABLE 1 TO § 100.801—SECTOR OHIO VALLEY ANNUAL AND RECURRING MARINE EVENTS—Continued

Date	Event/sponsor	Ohio valley location	Regulated area
24. 3 days—One of the last three weekends in June.	Hadi Shrine/Evansville Shriners Festival.	Evansville, IN .....	Ohio River, Mile 790.0–796.0 (Indiana).
25. 3 days—Third weekend in June.	TM Thunder LLC/Thunder on the Cumberland.	Nashville, TN .....	Cumberland River, Mile 189.6–192.3 (Tennessee).
26. 1 day—Third or fourth weekend in June.	Greater Morgantown Convention and Visitors Bureau/Mountaineer Triathlon.	Morgantown, WV .....	Monongahela River, Mile 101.0–102.0 (West Virginia).
27. 1 day—Fourth weekend in June.	Team Magic/Chattanooga Waterfront Triathlon.	Chattanooga, TN .....	Tennessee River, Mile 462.7–466.0 (Tennessee).
28. 1 day—One day in June .....	Guntersville Lake Hydrofest .....	Guntersville, AL .....	Tennessee River south of mile 357.0 in Browns Creek, starting at the AL–69 Bridge, 34°21'38" N, 86°20'36" W, to 34°21'14" N, 86°19'4" W, to the TVA power lines, 34°20'9" N, 86°21'7" W, to 34°19'37" N, 86°20'13" W, extending from bank to bank within the creek. (Alabama).
29. 3 days—The last weekend in June or one of the first two weekends in July.	Madison Regatta .....	Madison, IN .....	Ohio River, Mile 554.0–561.0 (Indiana).
30. 1 Day in July .....	Three Rivers Regatta .....	Knoxville, TN .....	Tennessee River, Mile 642–653 (Tennessee).
31. 1 Day in July .....	PADL .....	Cannelton, IN .....	Ohio River, Miles 719.0–727.0 (Kentucky).
32. 1 day—During the first week of July.	Evansville Freedom Celebration/4th of July Freedom Celebration.	Evansville, IN .....	Ohio River, Mile 790.0–797.0 (Indiana).
33. First weekend in July .....	Eddyville Creek Marina/Thunder Over Eddy Bay.	Eddyville, KY .....	Cumberland River, Mile 46.0–47.0 (Kentucky).
34. 2 days—One of the first two weekends in July.	Thunder on the Bay/KDBA .....	Pisgah Bay, KY .....	Tennessee River, Mile 30.0 (Kentucky).
35. 1 day—Second weekend in July.	Bradley Dean/Renaissance Man Triathlon.	Florence, AL .....	Tennessee River, Mile 254.0–258.0 (Alabama).
36. 1 day—Third or fourth Sunday of July.	Tucson Racing/Cincinnati Triathlon.	Cincinnati, OH .....	Ohio River, Mile 468.3–471.2 (Ohio).
37. 2 days—One of the last three weekends in July.	Dare to Care/KFC Mayor's Cup Paddle Sports Races/Voyageur Canoe World Championships.	Louisville, KY .....	Ohio River, Mile 600.0–605.0 (Kentucky).
38. 2 days—Last two weeks in July or first three weeks of August.	Friends of the Riverfront Inc./Pittsburgh Triathlon and Adventure Races.	Pittsburgh, PA .....	Allegheny River, Mile 0.0–1.5 (Pennsylvania).
39. 1 day—Fourth weekend in July.	Team Magic/Music City Triathlon	Nashville, TN .....	Cumberland River, Mile 189.7–192.3 (Tennessee).
40. 1 day—Last weekend in July ..	Maysville Paddlefest .....	Maysville, KY .....	Ohio River, Mile 408–409 (Kentucky).
41. 2 days—One weekend in July	Huntington Classic Regatta .....	Huntington, WV .....	Ohio River, Mile 307.3–309.3 (West Virginia).
42. 2 days—One weekend in July	Marietta Riverfront Roar Regatta	Marietta, OH .....	Ohio River, Mile 171.6–172.6 (Ohio).
43. 1 day—Last weekend in July or first weekend in August.	HealthyTriState.org/St. Marys Tri State Kayathalon.	Huntington, WV .....	Ohio River, Mile 305.1–308.3 (West Virginia).
44. 1 day—first Sunday in August	Above the Fold Events/Riverbluff Triathlon.	Ashland City, TN .....	Cumberland River, Mile 157.0–159.5 (Tennessee).
45. 3 days—First week of August	EQT Pittsburgh Three Rivers Regatta.	Pittsburgh, PA .....	Allegheny River mile 0.0–1.0, Ohio River mile 0.0–0.8, Monongahela River mile 0.5 (Pennsylvania).
46. 2 days—First weekend of August.	Thunder on the Bay/KDBA .....	Pisgah Bay, KY .....	Tennessee River, Mile 30.0 (Kentucky).
47.44. 1 day—First or second weekend in August.	Riverbluff Triathlon .....	Ashland City, TN .....	Cumberland River, Mile 157.0–159.0 (Tennessee).
48. 1 day—One of the first two weekends in August.	Green Umbrella/Ohio River Paddlefest.	Cincinnati, OH .....	Ohio River, Mile 458.5–476.4 (Ohio and Kentucky).
49. 2 days—Third full weekend (Saturday and Sunday) in August.	Ohio County Tourism/Rising Sun Boat Races.	Rising Sun, IN .....	Ohio River, Mile 504.0–508.0 (Indiana and Kentucky).
50. 3 days—Second or Third weekend in August.	Kittanning Riverbration Boat Races.	Kittanning, PA .....	Allegheny River mile 42.0–46.0 (Pennsylvania).
51. 3 days—One of the last two weekends in August.	Thunder on the Green .....	Livermore, KY .....	Green River, Mile 69.0–72.5 (Kentucky).

TABLE 1 TO § 100.801—SECTOR OHIO VALLEY ANNUAL AND RECURRING MARINE EVENTS—Continued

Date	Event/sponsor	Ohio valley location	Regulated area
52. 1 day—Fourth weekend in August.	Team Rocket Tri-Club/Rocketman Triathlon.	Huntsville, AL .....	Tennessee River, Mile 332.2–335.5 (Alabama).
53. 1 day—Last weekend in August.	Tennessee Clean Water Network/Downtown Dragon Boat Races.	Knoxville, TN .....	Tennessee River, Mile 646.3–648.7 (Tennessee).
54. 3 days—One weekend in August.	Pro Water Cross Championships	Charleston, WV .....	Kanawha River, Mile 56.7–57.6 (West Virginia).
55. 2 days—One weekend in August.	Powerboat Nationals—Ravenswood Regatta.	Ravenswood, WV .....	Ohio River, Mile 220.5–221.5 (West Virginia).
56. 2 days—One weekend in August.	Powerboat Nationals-Parkersburg Regatta/Parkersburg Homecoming.	Parkersburg, WV .....	Ohio River Mile 183.5–285.5 (West Virginia).
57. 1 day—One weekend in August.	YMCA River Swim .....	Charleston, WV .....	Kanawha River, Mile 58.3–61.8 (West Virginia).
58. 3 days—One weekend in August.	Grand Prix of Louisville .....	Louisville, KY .....	Ohio River, Mile 601.0–605.0 (Kentucky).
59. 3 days—One weekend in August.	Evansville HydroFest .....	Evansville, IN .....	Ohio River, Mile 790.5–794.0 (Indiana).
60. 3 days—One weekend in the month of August.	Owensboro HydroFair .....	Owensboro, KY .....	Ohio River, Mile 794.0–760.0 (Kentucky).
61. 1 day—First or second weekend of September.	SUP3Rivers The Southside Outside.	Pittsburgh, PA .....	Monongahela River mile 0.0–3.09 Allegheny River mile 0.0–0.6 (Pennsylvania).
62. 1 day—First weekend in September or on Labor Day.	Mayor's Hike, Bike and Paddle ....	Louisville, KY .....	Ohio River, Mile 601.0–610.0 (Kentucky).
63. 2 days—Sunday before Labor Day and Labor Day.	Cincinnati Bell, WEBN, and Proctor and Gamble/Riverfest.	Cincinnati, OH .....	Ohio River, Mile 463.0–477.0 (Kentucky and Ohio) and Licking River Mile 0.0–3.0 (Kentucky).
64. 2 days—Labor Day weekend	Wheeling Vintage Race Boat Association Ohio/Wheeling Vintage Regatta.	Wheeling, WV .....	Ohio River, Mile 90.4–91.5 (West Virginia).
65. 3 days—The weekend of Labor Day.	Portsmouth Boat Race/Breakwater Powerboat Association.	Portsmouth, OH .....	Ohio River, Mile 355.5–356.8 (Ohio).
66. 2 days—One of the first three weekends in September.	Louisville Dragon Boat Festival ....	Louisville, KY .....	Ohio River, Mile 602.0–604.5 (Kentucky).
67. 1 day—One of the first three weekends in September.	Cumberland River Compact/Cumberland River Dragon Boat Festival.	Nashville, TN .....	Cumberland River, Mile 189.7–192.1 (Tennessee).
68. 2 days—One of the first three weekends in September.	State Dock/Cumberland Poker Run.	Jamestown, KY .....	Lake Cumberland (Kentucky).
69. 3 days—One of the first three weekends in September.	Fleur de Lis Regatta .....	Louisville, KY .....	Ohio River, Mile 594.0–598.0 (Kentucky).
70. 1 day—Second weekend in September.	City of Clarksville/Clarksville Riverfest Cardboard Boat Regatta.	Clarksville, TN .....	Cumberland River, Mile 125.0–126.0 (Tennessee).
71. 1 day—One Sunday in September.	Ohio River Sternwheel Festival Committee Sternwheel race reenactment.	Marietta, OH .....	Ohio River, Mile 170.5–172.5 (Ohio).
72. 1 Day—One weekend in September.	Parkesburg Paddle Fest .....	Parkersburg, WV .....	Ohio River, Mile 184.3–188 (West Virginia).
73. 1 day—One weekend in September.	Shoals Dragon Boat Festival .....	Florence, AL .....	Tennessee River, Mile 255.0–257.0 (Alabama).
74. 2 days—One of the last three weekends in September.	Madison Vintage Thunder .....	Madison, IN .....	Ohio River, Mile 556.5–559.5 (Indiana).
75. 1 day—Third Sunday in September.	Team Rocket Tri Club/Swim Hobbs Island.	Huntsville, AL .....	Tennessee River, Mile 332.3–338.0 (Alabama).
76. 1 day—Fourth or fifth weekend in September.	Knoxville Open Water Swimmers/Bridges to Bluffs.	Knoxville, TN .....	Tennessee River, Mile 641.0–648.0 (Tennessee).
77. 1 day—Fourth or fifth Sunday in September.	Green Umbrella/Great Ohio River Swim.	Cincinnati, OH .....	Ohio River, Mile 468.8–471.2 (Ohio and Kentucky).
78. 1 day—One of the last two weekends in September.	Ohio River Open Water Swim .....	Prospect, KY .....	Ohio River, Mile 587.0–591.0 (Kentucky).
79. 2 days—One of the last three weekends in September or the first weekend in October.	Captain Quarters Regatta .....	Louisville, KY .....	Ohio River, Mile 594.0–598.0 (Kentucky).
80. 3 days—One of the last three weekends in September or one of the first two weekends in October.	Owensboro Air Show .....	Owensboro, KY .....	Ohio River, Mile 754.0–760.0 (Kentucky).
81. 1 day—Last weekend in September.	World Triathlon Corporation/IRONMAN Chattanooga.	Chattanooga, TN .....	Tennessee River, Mile 462.7–467.5 (Tennessee).

TABLE 1 TO § 100.801—SECTOR OHIO VALLEY ANNUAL AND RECURRING MARINE EVENTS—Continued

Date	Event/sponsor	Ohio valley location	Regulated area
82. 3 days—Last weekend of September and/or first weekend in October.	New Martinsville Records and Regatta Challenge Committee.	New Martinsville, WV .....	Ohio River, Mile 128–129 (West Virginia).
83. 2 days—First weekend of October.	Three Rivers Rowing Association/ Head of the Ohio Regatta.	Pittsburgh, PA .....	Allegheny River, Mile 0.0–5.0 (Pennsylvania).
84. 1 day in October .....	Chattajack .....	Chattanooga, TN .....	Tennessee River, Miles 462.7–465.5 (Tennessee).
85. 1 day in October .....	Outdoor Chattanooga/Swim the Suck.	Chattanooga, TN .....	Tennessee River, Miles 452.0–454.5 (Tennessee).
86. 1 day—First or second weekend in October.	Lookout Rowing Club/Chattanooga Head Race.	Chattanooga, TN .....	Tennessee River, Mile 463.0–468.0 (Tennessee).
87. 2 days—First or Second weekend in October.	Vanderbilt Rowing/Music City Head Race.	Nashville, TN .....	Cumberland River, Mile 189.5–196.0 (Tennessee).
88. 2 days—First or second week of October.	Head of the Ohio Rowing Race ...	Pittsburgh, PA .....	Allegheny River, Mile 0.0–3.0 (Pennsylvania).
89. 2 days—One of the first three weekends in October.	Norton Healthcare/Ironman Triathlon.	Louisville, KY .....	Ohio River, Mile 600.5–605.5 (Kentucky).
90. 2 days—Two days in October	Secret City Head Race Regatta ...	Oak Ridge, TN .....	Clinch River, Mile 49.0–54.0 (Tennessee).
91. 3 days—First weekend in November.	Atlanta Rowing Club/Head of the Hooch Rowing Regatta.	Chattanooga, TN .....	Tennessee River, Mile 463.0–468.0 (Tennessee).
92. 1 day—One weekend in November or December.	Charleston Lighted Boat Parade ..	Charleston, WV .....	Kanawha River, Mile 54.3–60.3 (West Virginia).

\* \* \* \* \*

Dated: January 26, 2022

A.M. Beach,

Captain, U.S. Coast Guard, Captain of the Port Sector Ohio Valley.

[FR Doc. 2022-01947 Filed 2-2-22; 8:45 am]

BILLING CODE 9110-04-P

**DEPARTMENT OF HOMELAND SECURITY**

**Coast Guard**

**33 CFR Part 165**

[Docket Number USCG-2021-0874]

RIN 1625-AA00

**Safety Zones; Coast Guard Sector Ohio Valley Annual and Recurring Safety Zones Update**

AGENCY: Coast Guard, DHS.

ACTION: Final rule.

**SUMMARY:** The Coast Guard is amending and updating its safety zone regulations for annual events that take place in the Coast Guard Sector Ohio Valley area of responsibility (AOR). This action is necessary to update the current list of recurring safety zones with revisions, additional events, and removal of events that no longer take place in the Sector Ohio Valley. When these safety zones are enforced, certain restrictions are placed on marine traffic in specified areas.

**DATES:** This rule is effective February 3, 2022.

**ADDRESSES:** To view documents mentioned in this preamble as being available in the docket, go to <https://www.regulations.gov>, type USCG-2021-0874 in the search box and click “Search.” Next, in the Document Type column, select “Supporting & Related Material.”

**FOR FURTHER INFORMATION CONTACT:** If you have questions on this rule, call or email Petty Officer Christopher Matthews, Sector Ohio Valley, U.S. Coast Guard; telephone 502-779-5334, email [Christopher.S.Matthews@uscg.mil](mailto:Christopher.S.Matthews@uscg.mil).

**SUPPLEMENTARY INFORMATION:**

**I. Table of Abbreviations**

- AOR Area of Responsibility
- COTP Captain of the Port Sector Ohio Valley
- CFR Code of Federal Regulations
- DHS Department of Homeland Security
- E.O. Executive Order
- FR Federal Register
- NPRM Notice of proposed rulemaking
- § Section
- U.S.C. United States Code

**II. Background Information and Regulatory History**

The Captain of Port Sector Ohio Valley (COTP) is amending 33 CFR 165.801 to update the table of annual fireworks displays and other events in Coast Guard Sector Ohio Valley Area of Responsibility (AOR). These events include air shows, fireworks displays, and other events requiring a safety zone.

On December 6, 2021, the Coast Guard published a notice of proposed rulemaking (NPRM) titled, Safety Zones;

Coast Guard Sector Ohio Valley Annual and Recurring Safety Zones Update (86 FR 68948). There we stated why we issued the NPRM, and invited comments on our proposed regulatory action related to those recurring safety zones. During the comment period that ended on January 5, 2022, no comments were received.

**III. Legal Authority and Need for Rule**

The Coast Guard is issuing this rule under authority in 46 U.S.C. 70034 (previously 33 U.S.C. 1231). The Coast Guard is amending and updating the safety zones under 33 CFR part 165 to include the most up to date list of recurring safety zones for events held on or around navigable waters within the Sector Ohio Valley AOR. These events include fireworks displays, air shows, and festivals. The current list in 33 CFR 165.801 requires amending to provide new information on existing safety zones and to include new safety zones expected to recur annually or biannually. Issuing individual regulations for each new safety zone, amendment of existing safety zones creates unnecessary administrative costs and burdens. This rulemaking reduces administrative overhead and provides the public with notice through publication in the **Federal Register** of the upcoming recurring safety zones. Based on the nature of these events, large numbers of participants and spectators, and event locations, the COTP has determined that the events listed in this rule could pose a risk to participants or waterways users if the

normal vessel traffic were to interfere with the events. Possible hazards include risks of injury or death from near or actual contact among participant vessels and spectators or mariners traversing through the regulated area. This purpose of this rule is to ensure the safety of all waterway users, including event participants and spectators, during the scheduled events.

#### IV. Discussion of Comments, Changes, and the Rule

As noted above, we received no comments on our NPRM published December 6, 2021. There is one change in the regulatory text of this rule from the proposed rule in the NPRM. The event Thunder Over Louisville will occur the 4th weekend of April this year. The text now reads in the table: 2 days—Third or fourth Friday and Saturday in April. The change is within the scope of the originally proposed event.

This rule amends and updates part 165 of 33 CFR by revising the current table for Sector Ohio Valley, and by adding two new recurring safety zones, removing four safety zones, and amending 1 safety zone as described in the NPRM. Vessels intending to transit the designated waterway through the safety zone will only be allowed to transit the area when the COTP, or designated representative, has deemed it safe to do so or at the completion of the event.

#### V. Regulatory Analyses

We developed this rule after considering numerous statutes and Executive orders related to rulemaking. Below we summarize our analyses based on a number of these statutes and Executive orders, and we discuss First Amendment rights of protestors.

##### A. Regulatory Planning and Review

Executive Orders 12866 and 13563 direct agencies to assess the costs and benefits of available regulatory alternatives and, if regulation is necessary, to select regulatory approaches that maximize net benefits. This rule has not been designated a “significant regulatory action,” under Executive Order 12866. Accordingly, this rule has not been reviewed by the Office of Management and Budget (OMB).

This regulatory action determination is based on the size, location, and duration of the safety zones. These safety zones are limited in size and duration, and are usually positioned away from high vessel traffic areas. Moreover, the Coast Guard would issue a Broadcast Notices to Mariners, Local

Notices to Mariners, and Marine Safety Information Broadcasts to inform the community of these safety zones.

##### B. Impact on Small Entities

The Regulatory Flexibility Act of 1980, 5 U.S.C. 601–612, as amended, requires Federal agencies to consider the potential impact of regulations on small entities during rulemaking. The term “small entities” comprises small businesses, not-for-profit organizations that are independently owned and operated and are not dominant in their fields, and governmental jurisdictions with populations of less than 50,000. The Coast Guard received no comments from the Small Business Administration on this rulemaking. The Coast Guard certifies under 5 U.S.C. 605(b) that this rule will not have a significant economic impact on a substantial number of small entities.

While some owners or operators of vessels intending to transit the safety zone may be small entities, for the reasons stated in section V.A above, this rule will not have a significant economic impact on any vessel owner or operator.

Under section 213(a) of the Small Business Regulatory Enforcement Fairness Act of 1996 (Pub. L. 104–121), we want to assist small entities in understanding this rule. If the rule would affect your small business, organization, or governmental jurisdiction and you have questions concerning its provisions or options for compliance, please call or email the person listed in the **FOR FURTHER INFORMATION CONTACT** section.

Small businesses may send comments on the actions of Federal employees who enforce, or otherwise determine compliance with, Federal regulations to the Small Business and Agriculture Regulatory Enforcement Ombudsman and the Regional Small Business Regulatory Fairness Boards. The Ombudsman evaluates these actions annually and rates each agency’s responsiveness to small business. If you wish to comment on actions by employees of the Coast Guard, call 1–888–REG–FAIR (1–888–734–3247). The Coast Guard will not retaliate against small entities that question or complain about this rule or any policy or action of the Coast Guard.

##### C. Collection of Information

This rule will not call for a new collection of information under the Paperwork Reduction Act of 1995 (44 U.S.C. 3501–3520).

##### D. Federalism and Indian Tribal Governments

A rule has implications for federalism under Executive Order 13132, Federalism, if it has a substantial direct effect on the States, on the relationship between the National Government and the States, or on the distribution of power and responsibilities among the various levels of government. We have analyzed this rule under that Order and have determined that it is consistent with the fundamental federalism principles and preemption requirements described in Executive Order 13132.

Also, this rule does not have tribal implications under Executive Order 13175, Consultation and Coordination with Indian Tribal Governments, because it does not have a substantial direct effect on one or more Indian tribes, on the relationship between the Federal Government and Indian tribes, or on the distribution of power and responsibilities between the Federal Government and Indian tribes.

##### E. Unfunded Mandates Reform Act

The Unfunded Mandates Reform Act of 1995 (2 U.S.C. 1531–1538) requires Federal agencies to assess the effects of their discretionary regulatory actions. In particular, the Act addresses actions that may result in the expenditure by a State, local, or tribal government, in the aggregate, or by the private sector of \$100,000,000 (adjusted for inflation) or more in any one year. Though this rule will not result in such an expenditure, we do discuss the effects of this rule elsewhere in this preamble.

##### F. Environment

We have analyzed this rule under Department of Homeland Security Directive 023–01, Rev. 1, associated implementing instructions, and Environmental Planning COMDTINST 5090.1 (series), which guide the Coast Guard in complying with the National Environmental Policy Act of 1969 (42 U.S.C. 4321–4370f), and have determined that this action is one of a category of actions that do not individually or cumulatively have a significant effect on the human environment. It is categorically excluded from further review under paragraph L60 of Appendix A, Table 1 of DHS Instruction Manual 023–01–001–01, Rev. 1. A Record of Environmental Consideration supporting this determination is available in the docket. For instructions on locating the docket, see the **ADDRESSES** section of this preamble.

G. Protest Activities

The Coast Guard respects the First Amendment rights of protesters. Protesters are asked to call or email the person listed in the **FOR FURTHER INFORMATION CONTACT** section to coordinate protest activities so that your message can be received without jeopardizing the safety or security of people, places or vessels.

List of Subjects in 33 CFR Part 165

Harbors, Marine safety, Navigation (water), Reporting and recordkeeping requirements, Security measures, Waterways.

For the reasons discussed in the preamble, the Coast Guard amends 33 CFR part 165 as follows:

**PART 165—REGULATED NAVIGATION AREAS AND LIMITED ACCESS AREAS**

■ 1. The authority citation for part 165 continues to read as follows:

**Authority:** 46 U.S.C. 70034, 70051; 33 CFR 1.05–1, 6.04–1, 6.04–6, and 160.5; Department of Homeland Security Delegation No. 0170.1, Revision No. 01.2.

■ 2. In § 165.801, revise Table 1 to read as follows:

**§ 165.801 Annual fireworks displays and other events in the Eighth Coast Guard District recurring safety zones.**

\* \* \* \* \*

TABLE 1 OF § 165.801—SECTOR OHIO VALLEY ANNUAL AND RECURRING SAFETY ZONES

Date	Sponsor/name	Sector Ohio Valley location	Safety zone
1. 3 days—Third or Fourth week-end in April.	Henderson Breakfast Lions Club Tri-Fest.	Henderson, KY .....	Ohio River, Miles 802.5–805.5 (Kentucky).
2. 2 days—Third or fourth Friday and Saturday in April.	Thunder Over Louisville .....	Louisville, KY .....	Ohio River, Miles 597.0–604.0 (Kentucky).
3. Multiple days—April through November.	Pittsburgh Pirates Season Fireworks.	Pittsburgh, PA .....	Allegheny River, Miles 0.2–0.9 (Pennsylvania).
4. Multiple days—April through November.	Cincinnati Reds Season Fireworks.	Cincinnati, OH .....	Ohio River, Miles 470.1–470.4; extending 500 ft. from the State of Ohio shoreline (Ohio).
5. Multiple days—April through November.	Pittsburgh Riverhounds Season Fireworks.	Pittsburgh, PA .....	Monongahela River, Miles 0.22–0.77 (Pennsylvania).
6. 1 day—First week in May .....	Belterra Park Gaming Fireworks ..	Cincinnati, OH .....	Ohio River, Miles 460.0–462.0 (Ohio).
7. 1 day—One Friday in May prior to Memorial Day.	Live on the Levee Memorial Day Fireworks/City of Charleston.	Charleston, WV .....	Kanawha River, Miles 58.1–59.1 (West Virginia).
8. 1 day—Saturday before Memorial Day.	Venture Outdoors Festival .....	Pittsburgh, PA .....	Allegheny River, Miles 0.0–0.25; Monongahela River, Miles 0.0–0.25 (Pennsylvania).
9. 3 days in June .....	CMA Festival .....	Nashville, TN .....	Cumberland River, Miles 190.7–191.1 extending 100 feet from the left descending bank (Tennessee).
10. 1 day in June .....	Cumberland River Compact/Nashville Splash Bash.	Nashville, TN .....	Cumberland River, Miles 189.7–192.1 (Tennessee).
11. 2 days—A weekend in June ....	Rice’s Landing Riverfest .....	Rice’s Landing, PA .....	Monongahela River, Miles 68.0–68.8 (Pennsylvania).
12. 2 days—Second Friday and Saturday in June.	City of Newport, KY/Italianfest ....	Newport, KY .....	Ohio River, Miles 468.6–471.0 (Kentucky and Ohio).
13. 1 day in June .....	Friends of the Festival, Inc./Riverbend Festival Fireworks.	Chattanooga, TN .....	Tennessee River, Miles 462.7–465.2 (Tennessee).
14. 1 day—Second or Third week of June.	TriState Pottery Festival Fireworks.	East Liverpool, OH .....	Ohio River, Miles 42.5–45.0 (Ohio).
15. 3 days—One of the last three weekends in June.	Hadi Shrine/Evansville Freedom Festival Air Show.	Evansville, IN .....	Ohio River, Miles 790.0–796.0 (Indiana).
16. 1 day—One weekend in June	West Virginia Symphony Orchestra/Symphony Sunday.	Charleston, WV .....	Kanawha River, Miles 59.5–60.5 (West Virginia).
17. One weekend in June .....	Alzheimer’s Water Lantern Festival/IC Care.	Wheeling, WV .....	Ohio River Mile 90.3–91.8.
18. 1 day—Last weekend in June or first weekend in July.	Riverview Park Independence Festival.	Louisville, KY .....	Ohio River, Miles 617.5–620.5 (Kentucky).
19. 1 day—Last weekend in June or First weekend in July.	City of Point Pleasant/Point Pleasant Sternwheel Fireworks.	Point Pleasant, WV .....	Ohio River, Miles 265.2–266.2, Kanawha River Miles 0.0–0.5 (West Virginia).
20. 1 day—Last weekend in June or first weekend in July.	City of Aurora/Aurora Firecracker Festival.	Aurora, IN .....	Ohio River, Mile 496.7; 1400 ft. radius from the Consolidated Grain Dock located along the State of Indiana shoreline at (Indiana and Kentucky).
21. 1 day—Last week of June or first week of July.	PUSH Beaver County/Beaver County Boom.	Beaver, PA .....	Ohio River, Miles 25.2–25.6 (Pennsylvania).
22. 1 day—Last weekend in June or first week in July.	Evansville Freedom Celebration/4th of July Fireworks.	Evansville, IN .....	Ohio River, Miles 790.0–796.0 (Indiana).
23. 1 day—Last week in June or First week in July.	Rising Sun Fireworks .....	Rising Sun, IN .....	Ohio River, Miles 506.0–507.0 (Indiana).



TABLE 1 OF § 165.801—SECTOR OHIO VALLEY ANNUAL AND RECURRING SAFETY ZONES—Continued

Date	Sponsor/name	Sector Ohio Valley location	Safety zone
24. 1 day—Weekend before the 4th of July.	Kentucky Dam Marine/Kentucky Dam Marina Fireworks.	Gilbertsville, KY .....	350 foot radius, from the fireworks launch site, on the entrance jetties at Kentucky Dam Marina, on the Tennessee River at Mile Marker 23 (Kentucky).
25. 1 day in July .....	Town of Cumberland City/Lighting up the Cumberlands.	Cumberland City, TN .....	Cumberland River, Miles 103.0–105.5 (Tennessee).
26. 1 day in July .....	Chattanooga Presents/Pops on the River.	Chattanooga, TN .....	Tennessee River, Miles 462.7–465.2 (Tennessee).
27. 1 day in July .....	Randy Boyd/Independence Celebration Fireworks Display.	Knoxville, TN .....	Tennessee River, Miles 625.0–628.0 (Tennessee).
28. 1 day—July 3rd .....	Moors Resort and Marina/Kentucky Lake Big Bang.	Gilbertsville, KY .....	600 foot radius, from the fireworks launch site, on the entrance jetty to Moors Resort and Marina, on the Tennessee River at mile marker 30.5. (Kentucky).
29. 1 day—3rd or 4th of July .....	City of Paducah, KY .....	Paducah, KY .....	Ohio River, Miles 934.0–936.0; Tennessee River, Miles 0.0–1.0 (Kentucky).
30. 1 day—3rd or 4th of July .....	City of Hickman, KY/Town Of Hickman Fireworks.	Hickman, KY .....	700 foot radius from GPS coordinate 36°34.5035 N, 089°11.919 W, in Hickman Harbor located at mile marker 921.5 on the Lower Mississippi River (Kentucky).
31. 1 day—July 4th .....	City of Knoxville/Knoxville Festival on the 4th.	Knoxville, TN .....	Tennessee River, Miles 646.3–648.7 (Tennessee).
32. 1 day in July .....	Nashville NCVC/Independence Celebration.	Nashville, TN .....	Cumberland River, Miles 189.7–192.3 (Tennessee).
33. 1 day in July .....	Shoals Radio Group/Spirit of Freedom Fireworks.	Florence, AL .....	Tennessee River, Miles 254.5–257.4 (Alabama).
34. 1 day—4th of July (Rain date—July 5th).	Monongahela Area Chamber of Commerce/Monongahela 4th of July Celebration.	Monongahela, PA .....	Monongahela River, Miles 032.0–033.0 (Pennsylvania).
35. 1 day—July 4th .....	Cities of Cincinnati, OH and Newport, KY/July 4th Fireworks.	Newport, KY .....	Ohio River, Miles 469.6–470.2 (Kentucky and Ohio).
36. 1 day—July 4th .....	Wellsburg 4th of July Committee/Wellsburg 4th of July Freedom Celebration.	Wellsburg, WV .....	Ohio River, Miles 73.5–74.5 (West Virginia).
37. 1 day—week of July 4th .....	Wheeling Symphony fireworks .....	Wheeling, WV .....	Ohio River, Miles 90–92 (West Virginia).
38. 1 day—First week or weekend in July.	Summer Motions Inc./Summer Motion.	Ashland, KY .....	Ohio River, Miles 322.1–323.1 (Kentucky).
39. 1 day—week of July 4th .....	Chester Fireworks .....	Chester, WV .....	Ohio River, Miles 42.0–44.0 (West Virginia).
40. 1 day—First week of July .....	Toronto 4th of July Fireworks .....	Toronto, OH .....	Ohio River, Miles 58.2–58.8 (Ohio).
41. 1 day—First week of July .....	Cincinnati Symphony Orchestra ...	Cincinnati, OH .....	Ohio River, Miles 460.0–462.0 (Ohio).
42. 1 day—First weekend or week in July.	Queen’s Landing Fireworks .....	Greenup, KY .....	Ohio River, Miles 339.3–340.3 (West Virginia).
43. 1 day—First week or weekend in July.	Gallia County Chamber of Commerce/Gallipolis River Recreation Festival.	Gallipolis, OH .....	Ohio River, Miles 269.5–270.5 (Ohio).
44. 1 day—First week or weekend in July.	Kindred Communications/Dawg Dazzle.	Huntington, WV .....	Ohio River, Miles 307.8–308.8 (West Virginia).
45. 1 day—First week or weekend in July.	Greenup City .....	Greenup, KY .....	Ohio River, Miles 335.2–336.2 (Kentucky).
46. 1 day—First week or weekend in July.	Middleport Community Association.	Middleport, OH .....	Ohio River, Miles 251.5–252.5 (Ohio).
47. 1 day—First week or weekend in July.	People for the Point Party in the Park.	South Point, OH .....	Ohio River, Miles 317–318 (Ohio).
48. 1 day—One of the first two weekends in July.	City of Bellevue, KY/Bellevue Beach Park Concert Fireworks.	Bellevue, KY .....	Ohio River, Miles 468.2–469.2 (Kentucky & Ohio).
49. 1 day— First Week of July .....	Pittsburgh 4th of July Celebration	Pittsburgh, PA .....	Ohio River, Miles 0.0–0.5, Allegheny River, Miles 0.0–0.5, and Monongahela River, Miles 0.0–0.5 (Pennsylvania).
50. 1 day—First week or weekend in July.	City of Charleston/City of Charleston Independence Day Celebration.	Charleston, WV .....	Kanawha River, Miles 58.1–59.1 (West Virginia).

TABLE 1 OF § 165.801—SECTOR OHIO VALLEY ANNUAL AND RECURRING SAFETY ZONES—Continued

Date	Sponsor/name	Sector Ohio Valley location	Safety zone
51. 1 day—First week or weekend in July.	Portsmouth River Days .....	Portsmouth, OH .....	Ohio River, Miles 355.5–357.0 (Ohio).
52. 1 day—During the first week of July.	Louisville Bats Baseball Club/Louisville Bats Firework Show.	Louisville, KY .....	Ohio River, Miles 602.0–605.0 (Kentucky).
53. 1 day—During the first week of July.	Waterfront Independence Festival/Louisville Orchestra Waterfront 4th.	Louisville, KY .....	Ohio River, Miles 602.0–605.0 (Kentucky).
54. 1 day—During the first week of July.	Celebration of the American Spirit Fireworks/All American 4th of July.	Owensboro, KY .....	Ohio River, Miles 754.0–760.0 (Kentucky).
55. 1 day—During the first week of July.	Riverfront Independence Festival Fireworks.	New Albany, IN .....	Ohio River, Miles 606.5–609.6 (Indiana).
56. 1 day in July .....	Grand Harbor Marina/Grand Harbor Marina July 4th Celebration.	Counce, TN .....	Tennessee-Tombigbee Waterway, Miles 448.5–451.0 (Tennessee).
57. 1 night in July .....	Steubenville fireworks .....	Steubenville, OH .....	Ohio River, Miles 67.5–68.5.
58. 1 day—During the first two weeks of July.	City of Maysville Fireworks .....	Maysville, KY .....	Ohio River, Miles 408–409 (Kentucky).
59. 1 day—One of the first two weekends in July.	Madison Regatta, Inc./Madison Regatta.	Madison, IN .....	Ohio River, Miles 554.0–561.0 (Indiana).
60. 1 day—Third Saturday in July	Pittsburgh Irish Rowing Club/St. Brendan's Cup Currach Regatta.	Pittsburgh, PA .....	Ohio River, Miles 7.0–9.0 (Pennsylvania).
61. 1 day—Third or fourth week in July.	Upper Ohio Valley Italian Heritage Festival/Upper Ohio Valley Italian Heritage Festival Fireworks.	Wheeling, WV .....	Ohio River, Miles 90.0–90.5 (West Virginia).
62. 1 day—Saturday Third or Fourth full week of July (Rain date—following Sunday).	Oakmont Yacht Club/Oakmont Yacht Club Fireworks.	Oakmont, PA .....	Allegheny River, Miles 12.0–12.5 (Pennsylvania).
63. 2 days—One weekend in July	Marietta Riverfront Roar Fireworks	Marietta, OH .....	Ohio River, Miles 171.6–172.6 (Ohio).
64. 1 day—Last weekend in July or first weekend in August.	Fort Armstrong Folk Music Festival.	Kittanning, PA .....	Allegheny River, Miles 45.1–45.5 (Pennsylvania).
65. 1 day—First week of August ...	Kittanning Folk Festival .....	Kittanning, PA .....	Allegheny River, Miles 44.0–46.0 (Pennsylvania).
66. 1 day—First week in August ...	Gliers Goetta Fest LLC .....	Newport, KY .....	Ohio River, Miles 469.0–471.0.
67. 1 day—First or second week of August.	Bellaire All-American Days .....	Bellaire, OH .....	Ohio River, Miles 93.5–94.5 (Ohio).
68. 1 day—Second full week of August.	PA FOB Fireworks Display .....	Pittsburgh, PA .....	Allegheny River, Miles 0.8–1.0 (Pennsylvania).
69. 1 day—Second Saturday in August.	Guyasuta Days Festival/Borough of Sharpsburg.	Pittsburgh, PA .....	Allegheny River, Miles 005.5–006.0 (Pennsylvania).
70. 1 day—In the Month of August	Pittsburgh Foundation/Bob O'Connor Cookie Cruise.	Pittsburgh, PA .....	Ohio River, Miles 0.0–0.5 (Pennsylvania).
71. 1 day—Third week of August ..	Beaver River Regatta Fireworks ..	Beaver, PA .....	Ohio River, Miles 25.2–25.8 (Pennsylvania).
72. 1 day—One weekend in August.	Parkersburg Homecoming Festival-Fireworks.	Parkersburg, WV .....	Ohio River, Miles 183.5–185.5 (West Virginia).
73. 1 day—One weekend in August.	Ravenswood River Festival .....	Ravenswood, WV .....	Ohio River, Miles 220–221 (West Virginia).
74. 1 day—The second or third weekend of August.	Green Turtle Bay Resort/Grand Rivers Marina Day.	Grand Rivers, KY .....	420 foot radius, from the fireworks launch site, at the entrance to Green Turtle Bay Resort, on the Cumberland River at mile marker 31.5. (Kentucky).
75. 1 day—last 2 weekends in August/first week of September.	Wheeling Dragon Boat Race .....	Wheeling, WV .....	Ohio River, Miles 90.4–91.5 (West Virginia).
76. 1 day—One weekend in the month of August or September.	Owensboro Fireworks and Bridge Lights show.	Owensboro, KY .....	Ohio River, Miles 756–757 (Kentucky).
77. Sunday, Monday, or Thursday from August through February.	Pittsburgh Steelers Fireworks .....	Pittsburgh, PA .....	Allegheny River, Miles 0.0–0.25, Ohio River, Miles 0.0–0.1, Monongahela River, Miles 0.0–0.1. (Pennsylvania).
78. 1 day—Labor day .....	Portsmouth Labor Day Fireworks/Hamburg Fireworks.	Portsmouth, OH .....	Ohio River, Miles 355.8–356.8 (Ohio).
79. 1 day—One weekend before Labor Day.	Riverfest/Riverfest Inc .....	Nitro, WV .....	Kanawha River, Miles 43.1–44.2 (West Virginia).
80. 1 day—The weekend of Labor Day.	Newburgh Fireworks Display .....	Newburgh, IN .....	Ohio River, Miles 777.3–778.3 (Indiana).

TABLE 1 OF § 165.801—SECTOR OHIO VALLEY ANNUAL AND RECURRING SAFETY ZONES—Continued

Date	Sponsor/name	Sector Ohio Valley location	Safety zone
81. 2 days—Sunday before Labor Day and Labor Day.	Cincinnati Bell, WEBN, and Proctor and Gamble/Riverfest.	Cincinnati, OH .....	Ohio River, Miles 469.2–470.5 (Kentucky and Ohio) and Licking River, Miles 0.0–3.0 (Kentucky).
82. 1 day—Labor Day or first week of September.	Labor Day Fireworks Show .....	Marmet, WV .....	Kanawha River, Miles 67.5–68 (West Virginia).
83. 1 day in September .....	Nashville Symphony/Concert Fireworks.	Nashville, TN .....	Cumberland River, Miles 190.1–192.3 (Tennessee).
84. 1 day—Second weekend in September.	City of Clarksville/Clarksville Riverfest.	Clarksville, TN .....	Cumberland River, Miles 124.5–127.0 (Tennessee).
85. 3 days—Second or third week in September.	Wheeling Heritage Port Sternwheel Festival Foundation/Wheeling Heritage Port Sternwheel Festival.	Wheeling, WV .....	Ohio River, Miles 90.2–90.7 (West Virginia).
86. 1 day—One weekend in September.	Boomtown Days—Fireworks .....	Nitro, WV .....	Kanawha River, Miles 43.1–44.2 (West Virginia).
87. 1 day—One weekend in September.	Ohio River Sternwheel Festival Committee fireworks.	Marietta, OH .....	Ohio River, Miles 171.5–172.5 (Ohio).
88. 1 day—One weekend in September.	Tribute to the River .....	Point Pleasant, WV .....	Ohio River, Miles 264.6–265.6 (West Virginia).
89. 1 day—One weekend in September.	Aurora Fireworks .....	Aurora, IN .....	Ohio River, Miles 496.3–497.3 (Ohio).
90. 1 day—Last two weekends in September.	Cabana on the River .....	Cincinnati, OH .....	Ohio River, Miles 483.2–484.2 (Ohio).
91. Multiple days—September through January.	University of Pittsburgh Athletic Department/University of Pittsburgh Fireworks.	Pittsburgh, PA .....	Ohio River, Miles 0.0–0.1, Monongahela River, Miles 0.0–0.1, Allegheny River, Miles 0.0–0.25 (Pennsylvania).
92. 1 day—First three weeks of October.	Leukemia & Lymphoma Society/Light the Night.	Pittsburgh, PA .....	Ohio River, Miles 0.0–0.5, Allegheny River, Miles 0.0–0.5, and Monongahela River, Miles 0.0–0.5 (Pennsylvania).
93. 1 day in October .....	Leukemia and Lymphoma Society/Light the Night Walk Fireworks.	Nashville, TN .....	Cumberland River, Miles 189.7–192.1 (Tennessee).
94. 1 day—First two weeks in October.	Yeatman’s Fireworks .....	Cincinnati, OH .....	Ohio River, Miles 469.0–470.5 (Ohio).
95. 1 day—One weekend in October.	West Virginia Motor Car Festival	Charleston, WV .....	Kanawha River, Miles 58–59 (West Virginia).
96. 2 days—One of the last three weekends in October.	Monster Pumpkin Festival .....	Pittsburgh, PA .....	Allegheny River, Miles 0.0–0.25 (Pennsylvania).
97. 1 day—Friday before Thanksgiving.	Pittsburgh Downtown Partnership/Light Up Night.	Pittsburgh, PA .....	Allegheny River, Miles 0.0–1.0 (Pennsylvania).
98. 1 day—Friday before Thanksgiving.	Kittanning Light Up Night Firework Display.	Kittanning, PA .....	Allegheny River, Miles 44.5–45.5 (Pennsylvania).
99. 1 day—Friday before Thanksgiving.	Santa Spectacular/Light up Night	Pittsburgh, PA .....	Ohio River, Miles 0.0–0.5, Allegheny River, Miles 0.0–0.5, and Monongahela River, Mile 0.0–0.5 (Pennsylvania).
100. 1 day—Friday before Thanksgiving.	Monongahela Holiday Show .....	Monongahela, PA .....	Ohio River, Miles 31.5–32.5 (Pennsylvania).
101. 1 day in November .....	Friends of the Festival/Cheer at the Pier.	Chattanooga, TN .....	Tennessee River, Miles 462.7–465.2 (Tennessee).
102. 1 day—Third week of November.	Gallipolis in Lights .....	Gallipolis, OH .....	Ohio River, Miles 269.2–270 (Ohio).
103. 1 day—December 31 .....	Pittsburgh Cultural Trust/Highmark First Night Pittsburgh.	Pittsburgh, PA .....	Allegheny River, Miles 0.5–1.0 (Pennsylvania).
104. 7 days—Scheduled home games.	University of Tennessee/UT Football Fireworks.	Knoxville, TN .....	Tennessee River, Miles 645.6–648.3 (Tennessee).

\* \* \* \* \*

Dated: January 26, 2022.

**A.M. Beach,**

*Captain, U.S. Coast Guard, Captain of the Port Sector Ohio Valley.*

[FR Doc. 2022–01948 Filed 2–2–22; 8:45 am]

**BILLING CODE 9110–04–P**

**ARCHITECTURAL AND  
TRANSPORTATION BARRIERS  
COMPLIANCE BOARD**

**36 CFR Part 1195**

[Docket No. ATBCB–2021–0002]

RIN 3014–AA45

**Standards for Accessible Medical  
Diagnostic Equipment**

**AGENCY:** Architectural and  
Transportation Barriers Compliance  
Board.

**ACTION:** Direct final rule.

**SUMMARY:** We, the Architectural and Transportation Barriers Compliance Board (hereafter, “Access Board” or “Board”), are issuing this direct final rule to extend, for three years, the sunset provisions in the Board’s existing accessibility standards for medical diagnostic equipment related to the low-height specifications for transfer surfaces to provide additional time for research necessary to determine the appropriate, final specification for the low transfer height position. The Access Board is issuing these amendments directly as a final rule because we believe they are noncontroversial, unlikely to receive adverse comment, and will serve the public interest.

**DATES:** This direct final rule is effective February 3, 2022, without further action, unless adverse comment is received by March 7, 2022. If timely adverse comment is received, the Access Board will publish a notification of withdrawal in the **Federal Register**. Such notification may withdraw the direct final rule in whole or in part.

**ADDRESSES:** You may submit comments by any one of the following methods:

- **Federal eRulemaking Portal:** <http://www.regulations.gov>. Follow the instructions for submitting comments.

- **Email:** [docket@access-board.gov](mailto:docket@access-board.gov). Include docket number ATBCB–2021–0002 in the subject line of the message.

- **Mail:** Office of General Counsel, U.S. Access Board, 1331 F Street NW, Suite 1000, Washington, DC 20004–1111.

**Instructions:** All submissions must include the docket number (ATBCB–2021–0002) for this regulatory action. All comments received will be posted without change to <http://www.regulations.gov>, including any personal information provided.

**Docket:** For access to the docket to read background documents or comments received, go to <https://www.regulations.gov>

[www.regulations.gov/docket/ATBCB-2022-0002](http://www.regulations.gov/docket/ATBCB-2022-0002).

**FOR FURTHER INFORMATION CONTACT:**  
Attorney Advisor Wendy Marshall,  
(202) 272–0043, [marshall@access-board.gov](mailto:marshall@access-board.gov).

**SUPPLEMENTARY INFORMATION:**

**Legal Authority**

Section 510 of the Rehabilitation Act charges the Access Board with developing and maintaining minimum technical criteria to ensure that “medical diagnostic equipment used in or in conjunction with physician’s offices, clinics, emergency rooms, hospitals, and other medical settings, is accessible to, and usable by, individuals with accessibility needs, and shall allow independent entry to, use of, and exit from the equipment by such individuals to the maximum extent possible.” 29 U.S.C. 794f. The Access Board’s minimum technical criteria do not impose any mandatory requirements on health care providers or medical device manufacturers. Adopting agencies or entities may, however, issue regulations or adopt policies requiring health care providers to acquire accessible medical diagnostic equipment that complies with the minimum technical criteria set forth by the Access Board.

**Purpose of Direct Final Rule**

In January 2017, the Board issued a final rule establishing accessibility standards for medical diagnostic equipment (MDE Standards). 82 FR 2810 (codified at 36 CFR part 1195). The MDE Standards set forth minimum technical criteria to ensure that medical diagnostic equipment used by health care providers (such as examination tables, weight scales, and imaging equipment) is accessible to, and usable by, individuals with disabilities. One of the areas covered by these Standards is the adjustability of transfer surfaces for certain types of medical diagnostic equipment. Specifically, for diagnostic equipment used by patients in a supine, prone, side-lying, or seated position, the MDE Standards specify the following adjustability requirements for transfer-height positions: A high height of 25 inches, a low height of 17–19 inches, and four unspecified intermediate heights between the high and low transfer height, which are separated by a minimum of one inch. 36 CFR part 1195, appendix, sections M301.2.1 & M302.2.2.

Unlike the other transfer height specifications, the low transfer height was set as a temporary range with five-year sunset provisions. *Id.* As explained

in the preamble to the final rule, the Board took this approach because “there was insufficient information to designate a single minimum low height requirement at this time. Specifically, there [was] insufficient data on the extent to which and how many individuals would benefit from a transfer height lower than 19 inches.” 82 FR at 2816. The Board thus specified a five-year sunset period to afford time for needed research and subsequent promulgation of a final specification for the low transfer height position. *Id.*

The Access Board is currently conducting research on low transfer heights; however, this research will not be completed in time for the Board to finalize a low transfer height specification prior to the expiration of the sunset period. By this rule, the Board thus extends the sunset provisions by an additional three years (*i.e.*, January 2025) so that there is no lapse in specifications for the low transfer height provisions while the Board completes both its research and the required rulemaking processes to establish final specifications.

**Regulatory Process Matters**

*A. Administrative Procedures Act and Good Cause Findings*

The Access Board is extending the sunset provisions in the MDE Standards without prior notice and opportunity for public comment because it has determined that such procedures are unnecessary and contrary to the public interest. *See* 5 U.S.C. 553(b)(B) (permitting agencies to bypass notice-and-comment procedures when, for good cause, they find prior notice “impracticable, unnecessary, or contrary to the public interest”). Extending the sunset provisions for the low transfer height provisions represents a minor, technical change that merely maintains the status quo for an additional three years. We thus believe the changes effected by this direct final rule will be noncontroversial and unlikely to draw adverse comment. Additionally, because the MDE Standards were promulgated through full notice-and-comment rulemaking, the public interest is best served by ensuring there is no lapse in low transfer height requirements. The Board thus finds good cause for waiver of prior notice and comment.

In addition, the Access Board finds good cause under 5 U.S.C. 553(d)(3) to

waive the 30-day delay in effectiveness of this rule. This finding is based upon the reasons provided above for waiver of prior notice and opportunity for public comment.

*B. Regulatory Planning and Review (Executive Orders 12866 and 13563)*

The Access Board has examined the impact of this direct final rule under Executive Orders 12866 and 13563. These executive orders direct agencies to assess the costs and benefits of available regulatory alternatives and, if regulation is necessary, to select regulatory approaches that maximize net benefits (including potential economic, environmental, public health and safety effects, distributive impacts, and equity). This rule does not impose any incremental costs or benefits because it simply extends the sunset period for the low transfer height requirement for an additional three years; it imposes no new or revised substantive obligations. As such, this direct final rule is not a significant regulatory action for purposes of section 3(f) of Executive Order 12866.

*C. Regulatory Flexibility Act*

The Regulatory Flexibility Act (RFA) requires federal agencies to analyze the impact of regulatory actions on small entities, unless an agency certifies that the rule will not have a significant impact on a substantial number of small entities. 5 U.S.C. 604, 605 (b). Because this direct final rule merely extends the existing sunset period for an additional three years to permit the Access Board to complete both its research and the required rulemaking processes to establish a permanent specification for the low transfer height position, the Access Board certifies that the rule will not have a significant economic impact on a substantial number of small entities.

*D. Federalism (Executive Order 13132)*

The Access Board has evaluated this direct final rule in accordance with the principles and criteria set forth in Executive Order 13132. We have determined that this action will not have a substantial direct effect on the States, the relationship between the Federal Government and the States, or on the distribution of power and responsibilities among the various levels of government, and, therefore, does not have Federalism implications.

*E. Unfunded Mandates Reform Act*

The Unfunded Mandates Reform Act of 1995 (codified at 2 U.S.C. 1531 *et seq.*) (“UMRA”) generally requires that Federal agencies assess the effects of

their discretionary regulatory actions that may result in the expenditure of \$100 million (adjusted for inflation) or more in any one year by the private sector, or by state, local, and tribal governments in the aggregate. Because this direct final rule is being issued under the APA’s good cause exception, UMRA’s analytical requirements are inapplicable. *See* 2 U.S.C. 1532(a).

*F. Paperwork Reduction Act*

Under the Paperwork Reduction Act (PRA), federal agencies are generally prohibited from conducting or sponsoring a “collection of information: As defined by the PRA, absent OMB approval. *See* 44 U.S.C. 3507 *et seq.* The MDE Standards do not impose any new or revised collections of information within the meaning of the PRA.

*G. Congressional Review Act*

This direct final rule is not a major rule within the meaning of the Congressional Review Act (5 U.S.C. 801 *et seq.*)

**List of Subjects in 36 CFR Part 1195**

Health care, Individuals with disabilities, Medical devices.

For the reasons stated in the preamble, and under the authority of 29 U.S.C. 794f, the Board amends 36 CFR part 1195 as follows:

**PART 1195—STANDARDS FOR ACCESSIBLE MEDICAL DIAGNOSTIC EQUIPMENT**

- 1. The authority citation for part 1195 continues to read as follows:

**Authority:** 29 U.S.C. 794f.

**Appendix to Part 1195—[Amended]**

- 2. In the appendix to part 1195:
  - a. In M301.2.2, remove the words “January 10, 2022” and add, in their place, the words “January 10, 2025”.
  - b. In M302.2.2, remove the words “January 10, 2022” and add, in their place, the words “January 10, 2025”.

Approved by notational vote of the Access Board on December 10, 2021.

**Sachin Pavithran,**  
*Executive Director.*

[FR Doc. 2022–02133 Filed 2–2–22; 8:45 am]

**BILLING CODE 8150–01–P**

**DEPARTMENT OF VETERANS AFFAIRS**

**38 CFR Part 3**

**RIN 2900–AR22**

**Extension of the Presumptive Period for Compensation for Gulf War Veterans**

**AGENCY:** Department of Veterans Affairs.

**ACTION:** Final rule.

**SUMMARY:** The Department of Veterans Affairs (VA) amends its adjudication regulations regarding compensation for disabilities resulting from undiagnosed illnesses suffered by veterans who served in the Persian Gulf War. This amendment is necessary to extend the presumptive period for qualifying chronic disabilities resulting from undiagnosed illnesses that must become manifest to a compensable degree in order for entitlement for disability compensation to be established. The intended effect of this amendment is to provide consistency in VA adjudication policy and preserve certain rights afforded to Persian Gulf War veterans and to ensure fairness for current and future Persian Gulf War veterans.

**DATES:**

*Effective date:* This final rule is effective February 3, 2022.

*Applicability date:* The provisions of this final rule shall apply to all applications for benefits that are received by VA on or after the effective date of this final rule or that are pending before VA, the United States Court of Appeals for Veterans Claims, or the United States Court of Appeals for the Federal Circuit on the effective date of this final rule.

**FOR FURTHER INFORMATION CONTACT:**

Bryant Coleman, Regulations Staff (211D), Compensation Service, Veterans Benefits Administration, 810 Vermont Avenue NW, Washington, DC 20420, (202) 461–9700. (This is not a toll-free telephone number.)

**SUPPLEMENTARY INFORMATION:** On September 14, 2021, VA published an interim final rule in the **Federal Register** at 86 FR 51000 to amend its adjudication regulation 38 CFR 3.317 regarding compensation for disabilities suffered by veterans who served in the Southwest Asia Theater of Operations during the Persian Gulf War. This amendment is necessary to extend the presumptive period during which disabilities associated with undiagnosed illnesses and medically unexplained chronic multi-symptom illnesses must become manifest in order for a veteran to be eligible for compensation. To

effectuate this rule, under 38 CFR 3.317(a)(1)(i), VA replaced the phrase “not later than December 31, 2021” with “not later than December 31, 2026.”

Under the provisions of 5 U.S.C. 553(b)(B) and (d)(3) the Secretary of Veterans Affairs found that there was good cause to publish this rule without prior opportunity for public comment. Had VA not extended the sunset date for the regulation, its authority to provide benefits in new claims for qualifying chronic disability in Gulf War veterans would have lapsed on December 31, 2021. A lapse of such authority would have been contrary to the public interest because it would have had a significant adverse impact on veterans disabled due to such disabilities. To avoid such impact, VA issued this rule as an interim final rule. However, VA invited interested persons to submit written comments on or before October 14, 2021, and received seven comments in response to the interim final rule. These comments are discussed below.

### General Comments

Three commenters referenced their poor health concerns or the poor health concerns of a family member. While VA sympathizes with anyone suffering from a debilitating disability and/or disease, the scope of this rule only addresses the deadline for the manifestation of presumptive conditions. VA makes no changes based on these comments.

One commenter suggested the regulation should contain VA’s definition of Southwest Asia. This rule merely extends the presumption period in 38 CFR 3.317, and that section already contains VA’s definition of the Southwest Asia theater of operations (in 38 CFR 3.317(e)(2)). VA makes no changes based on this comment.

One commenter suggested that since no end date for the Persian Gulf War has been established by Congress, any deadline is premature. However, this rule does not impose a deadline; it extends the presumptive period during which disabilities associated with undiagnosed illnesses and medically unexplained chronic multi-symptom illnesses must become manifest in order for a veteran to be eligible for compensation based on the presumption. VA makes no changes based on this comment.

VA received two non-substantive comments. VA makes no changes based on these comments.

As VA makes no changes based on the comments received, this document adopts as a final rule the interim final rule published in the **Federal Register** on September 14, 2021.

### Executive Orders 12866 and 13563

Executive Orders 12866 and 13563 direct agencies to assess the costs and benefits of available regulatory alternatives and, when regulation is necessary, to select regulatory approaches that maximize net benefits (including potential economic, environmental, public health and safety effects, and other advantages; distributive impacts; and equity). Executive Order 13563 (Improving Regulation and Regulatory Review) emphasizes the importance of quantifying both costs and benefits, reducing costs, harmonizing rules, and promoting flexibility. The Office of Information and Regulatory Affairs has determined that this rule is not a significant regulatory action under Executive Order 12866. The Regulatory Impact Analysis associated with this rulemaking can be found as a supporting document at [www.regulations.gov](http://www.regulations.gov).

### Regulatory Flexibility Act

The Secretary hereby certifies that this final rule will not have a significant economic impact on a substantial number of small entities as they are defined in the Regulatory Flexibility Act (5 U.S.C. 601–612). There are no small entities involved with the process and/or benefits associated with the rulemaking. Therefore, pursuant to 5 U.S.C. 605(b), the initial and final regulatory flexibility analysis requirements of 5 U.S.C. 603 and 604 do not apply.

### Unfunded Mandates

The Unfunded Mandates Reform Act of 1995 requires, at 2 U.S.C. 1532, that agencies prepare an assessment of anticipated costs and benefits before issuing any rule that may result in the expenditure by state, local, and tribal governments, in the aggregate, or by the private sector, of \$100 million or more (adjusted annually for inflation) in any one year. This final rule will have no such effect on state, local, and tribal governments, or on the private sector.

### Paperwork Reduction Act

This final rule contains no provisions constituting a collection of information under the Paperwork Reduction Act of 1995 (44 U.S.C. 3501–3521).

### Catalog of Federal Domestic Assistance

The Catalog of Federal Domestic Assistance numbers and titles for this rule are: 64.104, Pension for Non-Service-Connected Disability for Veterans; 64.109, Veterans Compensation for Service-Connected Disability.

### Congressional Review Act

Pursuant to the Congressional Review Act (5 U.S.C. 801 *et seq.*), the Office of Information and Regulatory Affairs designated this rule as not a major rule, as defined by 5 U.S.C. 804(2).

### List of Subjects in 38 CFR Part 3

Administrative practice and procedure, Claims, Disability benefits, Pensions, Veterans.

### Signing Authority

Denis McDonough, Secretary of Veterans Affairs, approved this document on January 19, 2022, and authorized the undersigned to sign and submit the document to the Office of the Federal Register for publication electronically as an official document of the Department of Veterans Affairs.

### Luvenia Potts,

*Regulation Development Coordinator, Office of Regulation Policy & Management, Office of General Counsel, Department of Veterans Affairs.*

■ For the reasons set forth in the preamble, the Department of Veterans Affairs adopts the interim rule published September 14, 2021, at 86 FR 51000, as final without change.

[FR Doc. 2022–02176 Filed 2–2–22; 8:45 am]

BILLING CODE 8320–01–P

## ENVIRONMENTAL PROTECTION AGENCY

### 40 CFR Part 180

[EPA–HQ–OPP–2021–0680; FRL–9399–01–OCSPP]

### Poly(oxy-1,2-ethanediyl)- $\alpha$ -hydro- $\omega$ -hydroxy-, Polymer With Poly(isocyanatoalkyl) Benzene, Alkylol-Blocked; Tolerance Exemption

**AGENCY:** Environmental Protection Agency (EPA).

**ACTION:** Final rule.

**SUMMARY:** This regulation establishes an exemption from the requirement of a tolerance for residues of Poly(oxy-1,2-ethanediyl)- $\alpha$ -hydro- $\omega$ -hydroxy-, polymer with poly(isocyanatoalkyl) benzene, alkylol-blocked when used as an inert ingredient in a pesticide chemical formulation. BYK USA Inc. submitted a petition to EPA under the Federal Food, Drug, and Cosmetic Act (FFDCA), requesting an exemption from the requirement of a tolerance. This regulation eliminates the need to establish a maximum permissible level for residues of Poly(oxy-1,2-ethanediyl)- $\alpha$ -hydro- $\omega$ -hydroxy-, polymer with

poly(isocyanatoalkyl) benzene, alkylol-blocked on food or feed commodities.

**DATES:** This regulation is effective February 3, 2022. Objections and requests for hearings must be received on or before April 4, 2022, and must be filed in accordance with the instructions provided in 40 CFR part 178 (see also Unit I.C. of the **SUPPLEMENTARY INFORMATION**).

**ADDRESSES:** The docket for this action, identified by docket identification (ID) number EPA-HQ-OPP-2021-0680, is available at <https://www.regulations.gov> or at the Office of Pesticide Programs Regulatory Public Docket (OPP Docket) in the Environmental Protection Agency Docket Center (EPA/DC), West William Jefferson Clinton Bldg., Rm. 3334, 1301 Constitution Ave. NW, Washington, DC 20460-0001. The Public Reading Room is open from 8:30 a.m. to 4:30 p.m., Monday through Friday, excluding legal holidays. The telephone number for the Public Reading Room is (202) 566-1744, and the telephone number for the OPP Docket is (703) 305-5805.

Due to the public health concerns related to COVID-19, the EPA Docket Center (EPA/DC) and Reading Room is closed to visitors with limited exceptions. The staff continues to provide remote customer service via email, phone, and webform. For the latest status information on EPA/DC services and docket access, visit <https://www.epa.gov/dockets>.

**FOR FURTHER INFORMATION CONTACT:** Marietta Echeverria, Registration Division (7505P), Office of Pesticide Programs, Environmental Protection Agency, 1200 Pennsylvania Ave. NW, Washington, DC 20460-0001; main telephone number: (703) 305-7090; email address: [RDFRNotices@epa.gov](mailto:RDFRNotices@epa.gov).

#### **SUPPLEMENTARY INFORMATION:**

##### **I. General Information**

###### *A. Does this action apply to me?*

You may be potentially affected by this action if you are an agricultural producer, food manufacturer, or pesticide manufacturer. The following list of North American Industrial Classification System (NAICS) codes is not intended to be exhaustive, but rather provides a guide to help readers determine whether this document applies to them. Potentially affected entities may include:

- Crop production (NAICS code 111).
- Animal production (NAICS code 112).
- Food manufacturing (NAICS code 311).
- Pesticide manufacturing (NAICS code 32532).

###### *B. How can I get electronic access to other related information?*

You may access a frequently updated electronic version of 40 CFR part 180 through the Office of the Federal Register's e-CFR site at <https://www.ecfr.gov/current/title-40>.

###### *C. Can I file an objection or hearing request?*

Under FFDCA section 408(g), 21 U.S.C. 346a, any person may file an objection to any aspect of this regulation and may also request a hearing on those objections. You must file your objection or request a hearing on this regulation in accordance with the instructions provided in 40 CFR part 178. To ensure proper receipt by EPA, you must identify docket ID number EPA-HQ-OPP-2021-0680 in the subject line on the first page of your submission. All objections and requests for a hearing must be in writing and must be received by the Hearing Clerk on or before April 4, 2022. Addresses for mail and hand delivery of objections and hearing requests are provided in 40 CFR 178.25(b).

In addition to filing an objection or hearing request with the Hearing Clerk as described in 40 CFR part 178, please submit a copy of the filing (excluding any Confidential Business Information (CBI)) for inclusion in the public docket. Information not marked confidential pursuant to 40 CFR part 2 may be disclosed publicly by EPA without prior notice. Submit the non-CBI copy of your objection or hearing request, identified by docket ID number EPA-HQ-OPP-2021-0680, by one of the following methods.

- **Federal eRulemaking Portal:** <https://www.regulations.gov>. Follow the online instructions for submitting comments. Do not submit electronically any information you consider to be CBI or other information whose disclosure is restricted by statute.

- **Mail:** OPP Docket, Environmental Protection Agency Docket Center (EPA/DC), (28221T), 1200 Pennsylvania Ave. NW, Washington, DC 20460-0001.

- **Hand Delivery:** To make special arrangements for hand delivery or delivery of boxed information, please follow the instructions at <https://www.epa.gov/dockets/contacts.html>.

Additional instructions on commenting or visiting the docket, along with more information about dockets generally, is available at <https://www.epa.gov/dockets>.

##### **II. Background and Statutory Findings**

In the **Federal Register** of October 21, 2021 (86 FR 58239) (FRL-8792-04-

OCSPP), EPA issued a document pursuant to FFDCA section 408, 21 U.S.C. 346a, announcing the receipt of a pesticide petition (PP IN-11586) filed by BYK USA Inc., 524 South Cherry St., Wallingford, CT 06492. The petition requested that 40 CFR 180.960 be amended by establishing an exemption from the requirement of a tolerance for residues of Poly(oxy-1,2-ethanediyl)- $\alpha$ -hydro- $\omega$ -hydroxy-, polymer with poly(isocyanatoalkyl) benzene, alkylol-blocked (No CAS Reg. No Associated). That document included a summary of the petition prepared by the petitioner and solicited comments on the petitioner's request. The Agency did not receive any comments.

Section 408(c)(2)(A)(i) of FFDCA allows EPA to establish an exemption from the requirement for a tolerance (the legal limit for a pesticide chemical residue in or on a food) only if EPA determines that the exemption is "safe." Section 408(c)(2)(A)(ii) of FFDCA defines "safe" to mean that "there is a reasonable certainty that no harm will result from aggregate exposure to the pesticide chemical residue, including all anticipated dietary exposures and all other exposures for which there is reliable information." This includes exposure through drinking water and use in residential settings but does not include occupational exposure. Section 408(b)(2)(C) of FFDCA requires EPA to give special consideration to exposure of infants and children to the pesticide chemical residue in establishing an exemption from the requirement of a tolerance and to "ensure that there is a reasonable certainty that no harm will result to infants and children from aggregate exposure to the pesticide chemical residue . . ." and specifies factors EPA is to consider in establishing an exemption.

##### **III. Risk Assessment and Statutory Findings**

EPA establishes exemptions from the requirement of a tolerance only in those cases where it can be shown that the risks from aggregate exposure to pesticide chemical residues under reasonably foreseeable circumstances will pose no appreciable risks to human health. In order to determine the risks from aggregate exposure to pesticide inert ingredients, the Agency considers the toxicity of the inert in conjunction with possible exposure to residues of the inert ingredient through food, drinking water, and through other exposures that occur as a result of pesticide use in residential settings. If EPA is able to determine that a finite tolerance is not necessary to ensure that there is a reasonable certainty that no

harm will result from aggregate exposure to the inert ingredient, an exemption from the requirement of a tolerance may be established.

Consistent with FFDCA section 408(b)(2)(D), EPA has reviewed the available scientific data and other relevant information in support of this action and considered its validity, completeness and reliability and the relationship of this information to human risk. EPA has also considered available information concerning the variability of the sensitivities of major identifiable subgroups of consumers, including infants and children. In the case of certain chemical substances that are defined as polymers, the Agency has established a set of criteria to identify categories of polymers expected to present minimal or no risk. The definition of a polymer is given in 40 CFR 723.250(b) and the exclusion criteria for identifying these low-risk polymers are described in 40 CFR 723.250(d). Poly(oxy-1,2-ethanediyl)- $\alpha$ -hydro- $\omega$ -hydroxy-, polymer with poly(isocyanatoalkyl) benzene, alkylol-blocked conforms to the definition of a polymer given in 40 CFR 723.250(b) and meets the following criteria that are used to identify low-risk polymers.

1. The polymer is not a cationic polymer nor is it reasonably anticipated to become a cationic polymer in a natural aquatic environment.

2. The polymer does contain as an integral part of its composition at least two of the atomic elements carbon, hydrogen, nitrogen, oxygen, silicon, and sulfur.

3. The polymer does not contain as an integral part of its composition, except as impurities, any element other than those listed in 40 CFR 723.250(d)(2)(ii).

4. The polymer is neither designed nor can it be reasonably anticipated to substantially degrade, decompose, or depolymerize.

5. The polymer is manufactured or imported from monomers and/or reactants that are already included on the TSCA Chemical Substance Inventory or manufactured under an applicable TSCA section 5 exemption.

6. The polymer is not a water absorbing polymer with a number average molecular weight (MW) greater than or equal to 10,000 daltons.

7. The polymer does not contain certain perfluoroalkyl moieties consisting of a CF<sub>3</sub>- or longer chain length as listed in 40 CFR 723.250(d)(6).

Additionally, the polymer also meets as required the following exemption criteria specified in 40 CFR 723.250(e).

8. The polymer's number average MW of 18,721 Daltons is greater than or equal to 10,000 daltons. However, the

polymer contains less than 2% oligomeric material below MW 500 (0%) and less than 5% oligomeric material below MW 1,000 (1.1%).

Thus, Poly(oxy-1,2-ethanediyl)- $\alpha$ -hydro- $\omega$ -hydroxy-, polymer with poly(isocyanatoalkyl) benzene, alkylol-blocked meets the criteria for a polymer to be considered low risk under 40 CFR 723.250. Based on its conformance to the criteria in this unit, no mammalian toxicity is anticipated from dietary, inhalation, or dermal exposure to Poly(oxy-1,2-ethanediyl)- $\alpha$ -hydro- $\omega$ -hydroxy-, polymer with poly(isocyanatoalkyl) benzene, alkylol-blocked.

#### IV. Aggregate Exposures

For the purposes of assessing potential exposure under this exemption, EPA considered that Poly(oxy-1,2-ethanediyl)- $\alpha$ -hydro- $\omega$ -hydroxy-, polymer with poly(isocyanatoalkyl) benzene, alkylol-blocked could be present in all raw and processed agricultural commodities and drinking water, and that non-occupational non-dietary exposure was possible. The number average MW of Poly(oxy-1,2-ethanediyl)- $\alpha$ -hydro- $\omega$ -hydroxy-, polymer with poly(isocyanatoalkyl) benzene, alkylol-blocked is 18,721 daltons. Generally, a polymer of this size would be poorly absorbed through the intact gastrointestinal tract or through intact human skin. Since Poly(oxy-1,2-ethanediyl)- $\alpha$ -hydro- $\omega$ -hydroxy-, polymer with poly(isocyanatoalkyl) benzene, alkylol-blocked conforms to the criteria that identify a low-risk polymer, there are no concerns for risks associated with any potential exposure scenarios that are reasonably foreseeable. The Agency has determined that a tolerance is not necessary to protect the public health.

#### V. Cumulative Effects From Substances With a Common Mechanism of Toxicity

Section 408(b)(2)(D)(v) of FFDCA requires that, when considering whether to establish, modify, or revoke a tolerance, the Agency consider "available information" concerning the cumulative effects of a particular pesticide's residues and "other substances that have a common mechanism of toxicity." EPA has not found Poly(oxy-1,2-ethanediyl)- $\alpha$ -hydro- $\omega$ -hydroxy-, polymer with poly(isocyanatoalkyl) benzene, alkylol-blocked to share a common mechanism of toxicity with any other substances, and Poly(oxy-1,2-ethanediyl)- $\alpha$ -hydro- $\omega$ -hydroxy-, polymer with poly(isocyanatoalkyl) benzene, alkylol-blocked does not appear to produce a

toxic metabolite produced by other substances. For the purposes of this tolerance action, therefore, EPA has assumed Poly(oxy-1,2-ethanediyl)- $\alpha$ -hydro- $\omega$ -hydroxy-, polymer with poly(isocyanatoalkyl) benzene, alkylol-blocked does not have a common mechanism of toxicity with other substances. For information regarding EPA's efforts to determine which chemicals have a common mechanism of toxicity and to evaluate the cumulative effects of such chemicals, see EPA's website at <https://www.epa.gov/pesticides/cumulative>.

#### VI. Determination of Safety

Based on the conformance to the criteria used to identify a low-risk polymer, EPA concludes that there is a reasonable certainty of no harm to the U.S. population, including infants and children, from aggregate exposure to residues of Poly(oxy-1,2-ethanediyl)- $\alpha$ -hydro- $\omega$ -hydroxy-, polymer with poly(isocyanatoalkyl) benzene, alkylol-blocked.

#### VII. Other Considerations

##### *Analytical Enforcement Methodology*

An analytical method is not required for enforcement purposes since the Agency is establishing an exemption from the requirement of a tolerance without any numerical limitation.

#### VIII. Conclusion

Accordingly, EPA finds that exempting residues of Poly(oxy-1,2-ethanediyl)- $\alpha$ -hydro- $\omega$ -hydroxy-, polymer with poly(isocyanatoalkyl) benzene, alkylol-blocked from the requirement of a tolerance will be safe.

#### IX. Statutory and Executive Order Reviews

This action establishes a tolerance under FFDCA section 408(d) in response to a petition submitted to the Agency. The Office of Management and Budget (OMB) has exempted these types of actions from review under Executive Order 12866, entitled "Regulatory Planning and Review" (58 FR 51735, October 4, 1993). Because this action has been exempted from review under Executive Order 12866, this action is not subject to Executive Order 13211, entitled "Actions Concerning Regulations That Significantly Affect Energy Supply, Distribution, or Use" (66 FR 28355, May 22, 2001) or Executive Order 13045, entitled "Protection of Children from Environmental Health Risks and Safety Risks" (62 FR 19885, April 23, 1997). This action does not contain any information collections subject to OMB approval under the Paperwork Reduction Act (PRA) (44



U.S.C. 3501 *et seq.*), nor does it require any special considerations under Executive Order 12898, entitled “Federal Actions to Address Environmental Justice in Minority Populations and Low-Income Populations” (59 FR 7629, February 16, 1994).

Since tolerances and exemptions that are established on the basis of a petition under FFDCA section 408(d), such as the tolerance in this final rule, do not require the issuance of a proposed rule, the requirements of the Regulatory Flexibility Act (RFA) (5 U.S.C. 601 *et seq.*), do not apply.

This action directly regulates growers, food processors, food handlers, and food retailers, not States or Tribes, nor does this action alter the relationships or distribution of power and responsibilities established by Congress in the preemption provisions of FFDCA section 408(n)(4). As such, the Agency has determined that this action will not have a substantial direct effect on States or Tribal Governments, on the relationship between the National Government and the States or Tribal Governments, or on the distribution of power and responsibilities among the various levels of government or between the Federal Government and Indian

Tribes. Thus, the Agency has determined that Executive Order 13132, entitled “Federalism” (64 FR 43255, August 10, 1999) and Executive Order 13175, entitled “Consultation and Coordination with Indian Tribal Governments” (65 FR 67249, November 9, 2000) do not apply to this action. In addition, this action does not impose any enforceable duty or contain any unfunded mandate as described under Title II of the Unfunded Mandates Reform Act (UMRA) (2 U.S.C. 1501 *et seq.*).

This action does not involve any technical standards that would require Agency consideration of voluntary consensus standards pursuant to section 12(d) of the National Technology Transfer and Advancement Act (NTTAA) (15 U.S.C. 272 note).

**X. Congressional Review Act**

Pursuant to the Congressional Review Act (5 U.S.C. 801 *et seq.*), EPA will submit a report containing this rule and other required information to the U.S. Senate, the U.S. House of Representatives, and the Comptroller General of the United States prior to publication of the rule in the **Federal Register**. This action is not a “major rule” as defined by 5 U.S.C. 804(2).

**List of Subjects in 40 CFR Part 180**

Environmental protection, Administrative practice and procedure, Agricultural commodities, Pesticides and pests, Reporting and recordkeeping requirements.

Dated: January 20, 2022.

**Marietta Echeverria,**

*Acting Director, Registration Division, Office of Pesticide Programs.*

Therefore, for the reasons stated in the preamble, EPA is amending 40 CFR chapter I as follows:

**PART 180—TOLERANCES AND EXEMPTIONS FOR PESTICIDE CHEMICAL RESIDUES IN FOOD**

■ 1. The authority citation for part 180 continues to read as follows:

**Authority:** 21 U.S.C. 321(q), 346a and 371.

■ 2. In § 180.960, amend table 1 by adding, in alphabetical order, the polymer “Poly(oxy-1,2-ethanediyl)- $\alpha$ -hydro- $\omega$ -hydroxy-, polymer with poly(isocyanatoalkyl) benzene, alkylol-blocked, number average molecular weight (Mn), 18,721” to read as follows:

**§ 180.960 Polymers; exemptions from the requirement of a tolerance.**

\* \* \* \* \*

Polymer	CAS No.
* * * * *	* * * * *
Poly(oxy-1,2-ethanediyl)- $\alpha$ -hydro- $\omega$ -hydroxy-, polymer with poly(isocyanatoalkyl) benzene, alkylol-blocked, number average molecular weight (Mn), 18,721.	(No CAS Reg. No. Associated).
* * * * *	* * * * *

[FR Doc. 2022-02100 Filed 2-2-22; 8:45 am]

BILLING CODE 6560-50-P

**GENERAL SERVICES ADMINISTRATION**

**41 CFR Parts 102-35 and 102-37**

[FMR Case 2018-102-6; Docket No. GSA-FMR-2019-0007, Sequence No. 2]

RIN 3090-AJ98

**Federal Management Regulation (FMR); Personal Property; Multiple Repeal or Replace Regulatory Actions; Multiple FMR Parts**

**AGENCY:** Office of Government-wide Policy (OGP), General Services Administration (GSA).

**ACTION:** Final rule.

**SUMMARY:** GSA is issuing a final rule to modify provisions in the Federal

Management Regulation (FMR) to improve readability and ease of use by reorganizing certain FMR parts to reflect the asset management life-cycle and by updating the definition of a ‘museum’.

**DATES:** *Effective:* March 7, 2022.

**FOR FURTHER INFORMATION CONTACT:** Mr. William Garrett, Program Director, Office of Government-wide Policy, at 202-368-8163, for clarification of content. For information pertaining to status or publication schedules, contact the Regulatory Secretariat at 202-501-4755. Please cite FMR Case 2018-102-6.

**SUPPLEMENTARY INFORMATION:**

**I. Background**

This final rule amends the FMR to improve readability and ease of use. Specifically, it reorganizes certain FMR parts to reflect the asset management life-cycle and updates the definition of a ‘museum’.

GSA sought public comments on improving FMR regulations through a **Federal Register** document (MA-2017-03) published on May 30, 2017, at 82 FR 24651. Concurrently, GSA sought comments and recommendations from agencies, GSA subject matter experts, and other stakeholders and customers.

The two substantive/germane comments and recommendations elicited from the **Federal Register** document were reviewed by GSA and are addressed in this rule. Two other recommendations addressing (1) agency asset management systems and (2) use of voluntary consensus standards were not included in this rule as GSA does not have the legal authority to promulgate regulations addressing property in use by an agency before it is reported to GSA as excess personal property.

Provisions in this final rule make the FMR policies addressing personal

property management more understandable and easier to read. This final rule addresses the following:

1. An amendment to FMR section 102–35.10, listing FMR parts related to personal property disposal in sequence so that the listing of FMR parts follows the general life-cycle processes related to asset management and disposal; and

2. Revisions to the regulations governing the donation program to incorporate legislation regarding museums (Pub. L. 114–287, Section 23) to ensure consistency with Federal law. The donation program allows for the transfer of Federal surplus personal property to state agencies for surplus property for distribution to eligible recipients within their state.

## II. Discussion of the Final Rule

### A. Summary of Significant Changes

GSA is modifying provisions in the FMR to improve readability and ease of use.

### B. Analysis of Public Comments

The proposed rule was published in the **Federal Register** on June 9, 2020 (85 FR 35236). Four comments were received, two of which were substantive/germane to the rule. An analysis of these public comments follows:

*Comment:* One respondent indicated that the proposed rule “is bad for the environment and public safety” and should not be implemented.

*Response:* These changes do not involve environmental concerns or public safety.

*Comment:* One respondent objected to “eliminating all definition references in this proposed rule” and that it is important to have definitions repeated in each area that are critical for understanding the requirements.

*Response:* Concur. The consolidation of duplicative occurrences of definitions has been removed from this final rule.

### C. Expected Cost Impact to the Public

There is no expected cost to the public from this rule, as this rule is largely administrative. The changes will result in a better user experience with the FMR, as the information will be organized in a more logical order.

## III. Executive Orders 12866 and 13563

Executive Orders (E.O.s) 12866 and 13563 direct agencies to assess all costs and benefits of available regulatory alternatives and, if regulation is necessary, to select regulatory approaches that maximize net benefits (including potential economic, environmental, public health and safety effects, distributive impacts, and

equity). E.O. 13563 emphasizes the importance of quantifying both costs and benefits, of reducing costs, of harmonizing rules, and of promoting flexibility. This rule is not a significant regulatory action, and therefore, was not subject to review under Section 6(b) of E.O. 12866, Regulatory Planning and Review, dated September 30, 1993.

## IV. Congressional Review Act

This rule is not a major rule under 5 U.S.C. 804(2). Additionally, this rule is excepted from Congressional Review Act reporting requirements prescribed under 5 U.S.C. 801 since it relates to agency management or personnel.

## V. Regulatory Flexibility Act

This final rule will not have a significant economic impact on a substantial number of small entities within the meaning of the Regulatory Flexibility Act, 5 U.S.C. 601, *et seq.* This final rule is also exempt from the Administrative Procedures Act per 5 U.S.C. 553(a)(2) because it applies to agency management or personnel.

## VI. Paperwork Reduction Act

The Paperwork Reduction Act does not apply because the changes to the FMR do not impose recordkeeping or information collection requirements, or the collection of information from offerors, contractors, or members of the public that require the approval of the Office of Management and Budget (OMB) under 44 U.S.C. 3501, *et seq.*

## List of Subjects in 41 CFR Parts 102–35 and 102–37

Government property management.

### Robin Carnahan,

*Administrator of General Services.*

For the reasons set forth in the preamble, GSA amends 41 CFR parts 102–35 and 102–37 as set forth below:

## PART 102–35—DISPOSITION OF PERSONAL PROPERTY

■ 1. The authority for part 102–35 continues to read as follows:

**Authority:** 40 U.S.C. 121(c).

■ 2. Amend § 102–35.10 by revising paragraphs (e) thru (g) to read as follows:

### § 102–35.10 How are these regulations for the disposal of personal property organized?

\* \* \* \* \*

(e) Utilization and disposition of personal property with special handling requirements (part 102–40 of this subchapter B).

(f) Disposition of seized, forfeited, voluntarily abandoned, and unclaimed

personal property (part 102–41 of this subchapter B).

(g) Utilization, donation, and disposal of foreign gifts and decorations (part 102–42 of this subchapter B).

## PART 102–37—DONATION OF SURPLUS PERSONAL PROPERTY

■ 3. The authority for part 102–37 continues to read as follows:

**Authority:** 40 U.S.C. 549 and 121(c).

■ 4. Amend appendix C to part 102–37 by revising the definition of “Museum” to read as follows:

### Appendix C to Part 102–37—Glossary of Terms for Determining Eligibility of Public Agencies and Nonprofit Organizations

\* \* \* \* \*

*Museum* means a public agency or nonprofit educational or public health institution that is organized on a permanent basis for essentially educational or aesthetic purposes and which, using a professional staff, owns or uses tangible objects, either animate or inanimate; and cares for these objects. A museum is considered to be attended by the public if the museum, at minimum, accedes to any request submitted for access during business hours. For the purposes of this definition, a museum uses a professional staff if it employs at least one full-time staff member or the equivalent, whether paid or unpaid, primarily engaged in the acquisition, care, or public exhibition of objects owned or used by the museum.

[FR Doc. 2022–02167 Filed 2–2–22; 8:45 am]

BILLING CODE 6820–14–P

## FEDERAL COMMUNICATIONS COMMISSION

### 47 CFR Part 73

[MB Docket No. 21–125; RM–11892; DA 22–91; FR ID 70015]

### Television Broadcasting Services Hazard, Kentucky

**AGENCY:** Federal Communications Commission.

**ACTION:** Final rule.

**SUMMARY:** On September 22, 2021, the Media Bureau, Video Division (Bureau) issued a *Notice of Proposed Rulemaking (NPRM)* in response to a petition for rulemaking filed by Gray Television Licensee, LLC (Petitioner), the licensee of WYMT, channel 12, Hazard, Kentucky, requesting the substitution of channel 20 for channel 12 at Hazard in the Table of Allotments. For the reasons set forth in the *Report and Order* referenced below, the Bureau amends Federal Communications Commission (FCC) regulations to substitute channel 20 for channel 12 at Hazard.

**DATES:** Effective February 3, 2022.

**FOR FURTHER INFORMATION CONTACT:** Joyce Bernstein, Media Bureau, at (202) 418-1647 or Joyce.Bernstein@fcc.gov.

**SUPPLEMENTARY INFORMATION:** The proposed rule was published at 86 FR 54416 on October 1, 2021. The Petitioner filed comments in support of the petition reaffirming its commitment to apply for channel 20. In support of its channel substitution request, the Petitioner states that the Commission has recognized the deleterious effects manmade noise has on the reception of digital VHF signals, and that the propagation characteristics of these channels allow undesired signals and noise to be receivable at relatively farther distances compared to UHF channels, and also allow nearby electrical devices to cause interference. While the proposed channel 20 facility is predicted to result in loss of service to 15,460 persons, all but approximately 100 of those persons would continue to receive service from at least five other television stations, and no persons would receive service from fewer than four other television stations. The Commission is generally most concerned where there is a loss of an area's only network or non-commercial educational (NCE) TV service, or where the loss area results in an area becoming less than well-served, *i.e.*, served by fewer than five full-power over-the-air signals. As a result, the loss area will continue to remain well-served and the number of persons that will receive less than five signals (approximately 100 persons) is considered to be *de minimis*.

This is a synopsis of the Commission's *Report and Order*, MB Docket No. 21-125; RM-11892; DA 22-91, adopted January 27, 2022, and released January 27, 2022. The full text of this document is available for download at <https://www.fcc.gov/edocs>. To request materials in accessible formats for people with disabilities (braille, large print, electronic files, audio format), send an email to [fcc504@fcc.gov](mailto:fcc504@fcc.gov) or call the Consumer & Governmental Affairs Bureau at 202-418-0530 (voice), 202-418-0432 (tty).

This document does not contain information collection requirements subject to the Paperwork Reduction Act of 1995, Public Law 104-13. In addition, therefore, it does not contain any proposed information collection burden "for small business concerns with fewer than 25 employees," pursuant to the Small Business Paperwork Relief Act of 2002, Public Law 107-198, *see* 44 U.S.C. 3506(c)(4). Provisions of the Regulatory Flexibility Act of 1980, 5 U.S.C. 601-612, do not apply to this proceeding.

The Commission will send a copy of the *Report and Order* in a report to be sent to Congress and the Government Accountability Office pursuant to the Congressional Review Act, *see* 5 U.S.C. 801(a)(1)(A).

**List of Subjects in 47 CFR Part 73**

Television.  
Federal Communications Commission.  
**Thomas Horan,**  
*Chief of Staff, Media Bureau.*

**Final Rule**

For the reasons discussed in the preamble, the Federal Communications Commission amends 47 CFR part 73 as follows:

**PART 73—RADIO BROADCAST SERVICES**

■ 1. The authority citation for part 73 continues to read as follows:

**Authority:** 47 U.S.C. 154, 155, 301, 303, 307, 309, 310, 334, 336, 339.

■ 2. In § 73.622(j), amend the Table of Allotments, under Kentucky, by revising the entry for Hazard to read as follows:

**§ 73.622 Digital television table of allotments.**

	Community	Channel No.
(j) * * *	* * *	* * *
<b>KENTUCKY</b>		
Hazard .....		20, * 33.
* * *	* * *	* * *

[FR Doc. 2022-02213 Filed 2-2-22; 8:45 am]

**BILLING CODE 6712-01-P**

**GENERAL SERVICES ADMINISTRATION**

**48 CFR Parts 538 and 552**

[**GSAR Case 2021-G529; Docket No. GSA-GSAR 2022-0006; Sequence No. 1**]

**RIN 3090-AK50**

**General Services Administration Acquisition Regulation (GSAR); Updates to References to Individuals With Disabilities**

**AGENCY:** Office of Acquisition Policy, General Services Administration (GSA).

**ACTION:** Final rule.

**SUMMARY:** The General Services Administration (GSA) is amending the

General Services Administration Acquisition Regulation (GSAR) to provide more inclusive acquisition guidance for underserved communities by updating references from "handicapped individuals" to "individuals with disabilities," pursuant to Section 508 of the Rehabilitation Act. This rule supports underserved communities, promoting equity in the Federal Government.

**DATES:** *Effective:* March 7, 2022.

**FOR FURTHER INFORMATION CONTACT:** For clarification of content, contact Mr. Joseph Goldberg or Ms. Adina Torberntsson, GSA Acquisition Policy Division, at 303-236-2677 or [gsarpolicy@gsa.gov](mailto:gsarpolicy@gsa.gov). For information pertaining to status or publication schedules, contact the Regulatory Secretariat Division at 202-501-4755 or [GSARegSec@gsa.gov](mailto:GSARegSec@gsa.gov). Please cite GSAR Case 2021-G529.

**SUPPLEMENTARY INFORMATION:**

**I. Background**

Currently, the GSAR uses the terms "handicapped" and "handicapped individuals" to identify individuals with impairments who can benefit from certain electronic office equipment. However, the Americans with Disabilities Act and the Rehabilitation Act use the term "individuals with disabilities" to reference these individuals. Thus, this rule updates language in the GSAR to conform with the statutory language and provide more inclusive acquisition guidance for underserved communities.

**II. Authority for This Rulemaking**

Title 40 of the United States Code (U.S.C.) Section 121 authorizes GSA to issue regulations, including the GSAR, to control the relationship between GSA and contractors.

**III. Discussion and Analysis**

This rule revises the term "handicapped" to "individuals with disabilities" at 552.238-73. Additionally, the rule updates the GSAR to guide the reader to 29 U.S.C. 705(20) for the definition of "individuals with disabilities", replacing an outdated reference to 29 CFR 1613.702 for the definition of "handicapped."

**IV. Executive Orders 12866 and 13563**

Executive Orders (E.O.s) 12866 and 13563 direct agencies to assess all costs and benefits of available regulatory alternatives and, if regulation is necessary, to select regulatory approaches that maximize net benefits (including potential economic, environmental, public health and safety

effects, distributive impacts, and equity). E.O. 13563 emphasizes the importance of quantifying both costs and benefits, of reducing costs, of harmonizing rules, and of promoting flexibility. This rule has been reviewed and determined by OMB not to be a significant regulatory action and, therefore, was not subject to review under section 6(b) of E.O. 12866, Regulatory Planning and Review, dated September 30, 1993.

#### V. Congressional Review Act

The Congressional Review Act, 5 U.S.C. 801 *et seq.*, as amended by the Small Business Regulatory Enforcement Fairness Act of 1996, generally provides that before a “major rule” may take effect, the agency promulgating the rule must submit a rule report, which includes a copy of the rule, to each House of the Congress and to the Comptroller General of the United States. A major rule cannot take effect until 60 days after it is published in the **Federal Register**. This rule has been reviewed and determined by OMB not to be a “major rule” under 5 U.S.C. 804(2).

#### VI. Notice for Public Comment

The statute that applies to the publication of the GSAR is the Office of Federal Procurement Policy statute (codified at title 41 of the United States Code). Specifically, 41 U.S.C. 1707(a)(1) requires that a procurement policy, regulation, procedure or form (including an amendment or modification thereof) must be published for public comment if it relates to the expenditure of appropriated funds and has either a significant effect beyond the internal operating procedures of the agency issuing the policy, regulation, procedure, or form, or has a significant cost or administrative impact on contractors or offerors. This rule is not required to be published for public comment, because GSA is not issuing a new regulation. This rule does not add any new solicitation provisions or contract clauses. It does not add any new burdens because the case does not add or change any requirements with which vendors must comply. Rather, this rule is merely an editorial change and will provide consistent language to statute.

#### VII. Regulatory Flexibility Act

The Regulatory Flexibility Act (5 U.S.C. 601 *et seq.*) does not apply to this rule, because an opportunity for public comment is not required to be given for this rule under 41 U.S.C. 1707(a)(1) (see Section VI of this preamble). Accordingly, no regulatory flexibility

analysis is required, and none has been prepared.

#### VIII. Paperwork Reduction Act

The rule does not contain any information collection requirements that require the approval of the Office of Management and Budget under the Paperwork Reduction Act (44 U.S.C. chapter 35).

#### List of Subjects in 48 CFR Parts 538 and 552

Government procurement.

Jeffrey A. Koses,

*Senior Procurement Executive, Office of Acquisition Policy, Office of Government-wide Policy, General Services Administration.*

Therefore, GSA amends 48 CFR parts 538 and 552 as set forth below:

■ 1. The authority citation for 48 CFR parts 538 and 552 continues to read as follows:

Authority: 40 U.S.C. 121(c).

#### PART 538—FEDERAL SUPPLY SCHEDULE CONTRACTING

##### 538.273 [Amended]

■ 2. Amend section 538.273 by removing from paragraph (b)(1) the phrase “the Handicapped” and adding “Individuals with Disabilities” in its place.

#### PART 552—SOLICITATION PROVISIONS AND CONTRACT CLAUSES

■ 3. Revise section 552.238–73 to read as follows:

##### 552.238–73 Identification of Electronic Office Equipment Providing Accessibility for Individuals with Disabilities.

As prescribed in 538.273(b)(1), insert the following clause:

##### Identification of Electronic Office Equipment Providing Accessibility for Individuals With Disabilities (Mar 2022)

(a) *Definitions.*

*Electronic office equipment accessibility* means the application/configuration of electronic office equipment (includes hardware, software and firmware) in a manner that accommodates the functional limitations of individuals with disabilities (as defined below) so as to promote productivity and provide access to work related and/or public information resources.

*Individuals with disabilities* means qualified individuals with impairments as defined in 29 U.S.C. 705(20) who can benefit from electronic office equipment accessibility.

*Special peripheral* means a special needs aid that provides access to electronic equipment that is otherwise inaccessible to individuals with disabilities.

(b) The offeror is encouraged to identify in its offer and include in any commercial

catalogs and pricelists accepted by the Contracting Officer, office equipment, including any special peripheral, that will facilitate electronic office equipment accessibility for individuals with disabilities. Identification should include the type of disability accommodated and how the users with that disability would be helped.

(End of clause)

[FR Doc. 2022–02194 Filed 2–2–22; 8:45 am]

BILLING CODE 6820–61–P

## DEPARTMENT OF TRANSPORTATION

### Federal Motor Carrier Safety Administration

#### 49 CFR Part 383

[Docket No. FMCSA–2020–0197]

#### Commercial Driver’s License Standards: Regulatory Guidance Concerning Third Party Testers Conducting the Knowledge Test

**AGENCY:** Federal Motor Carrier Safety Administration (FMCSA), Department of Transportation (DOT).

**ACTION:** Regulatory guidance.

**SUMMARY:** FMCSA amends its regulatory guidance to explain that FMCSA’s current statutory authorities and regulations do not prohibit third party testers from administering the commercial driver’s license knowledge tests for all classes and endorsements. SDLAs may accept the results of knowledge tests administered by third party testers in accordance with existing knowledge test standards and requirements set forth in 49 CFR part 383, subparts G and H.

**DATES:** This guidance is effective February 3, 2022.

**FOR FURTHER INFORMATION CONTACT:** Ms. Nikki McDavid, Chief of the CDL Division, FMCSA, 1200 New Jersey Avenue SE, Washington, DC 20590–0001, [nikki.mcdavid@dot.gov](mailto:nikki.mcdavid@dot.gov), 202–366–0831.

#### SUPPLEMENTARY INFORMATION:

##### I. Background

On May 9, 2011, FMCSA published the 49 CFR parts 383, 384 and 385, Commercial Driver’s License Testing and Commercial Learner’s Permit Standards final rule (76 FR 26854) that amended the commercial driver’s license (CDL) knowledge and skills testing standards and established new minimum Federal standards for States to issue the commercial learner’s permit. The final rule also set forth the Federal standards for States to allow

third party testers to administer the CDL skills test.

On April 3, 2020, the Virginia Department of Motor Vehicles (VA DMV) requested an exemption from 49 CFR 383.75 to allow non-government third party testers to administer knowledge tests for CDL and CLP applicants without a State examiner being present. The VA DMV's request was prompted by the closure of VA DMV service centers resulting from the COVID-19 public health emergency. In response to the VA DMV's request, FMCSA indicated that applicable statutes and regulations do not currently prohibit States from allowing a third party to administer CDL and CLP knowledge tests. The Agency also noted its intention to revise the existing guidance, set forth below, to clarify this point.

Regulatory guidance question 1 for 49 CFR 383.75, "Third Party Testing," first issued in 1993 (58 FR 60734, 60739 (Nov. 17, 1993)) and most recently reissued in 2019, states:

*Question 1:* May the CDL knowledge test be administered by a third party?

*Guidance:* No. The third party testing provision found in § 383.75 applies only to the skills portion of the testing procedure. However, if an employee of the State who is authorized to supervise knowledge testing is present during the testing, then FMCSA regards it as being administered by the State and not by a third party. (84 FR 8464, 8472 (Mar. 8, 2019); 62 FR 16370, 16399 (Apr. 4, 1997)).

FMCSA has reconsidered this guidance and concludes that nothing in the Agency's current authorities in 49 U.S.C. chapters 311 or 313, or in 49 CFR parts 383 and 384, prohibits States from permitting third party testers to administer CDL knowledge tests. Accordingly, the Agency amends regulatory guidance question 1 for 49 CFR 383.75 to explain that a State may permit third parties to administer CDL knowledge tests. Pursuant to 49 CFR 384.202, States opting to permit this practice must adhere to current CDL knowledge test standards and requirements set forth in 49 CFR part 383, subparts G and H. FMCSA is currently working on a Notice of Proposed Rulemaking to more fully address the States' use of third party knowledge testers.

## II. Regulatory Guidance

FMCSA issues the following guidance:

Regulatory Guidance to 49 CFR part 383—Commercial Driver's License Standards Section 383.75 Third Party Testing, Guidance ID No. FMCSA-CDL-383.75-Q1-M

*Question 1:* May States allow third party testers to administer CDL knowledge tests for

all classes and endorsements, without any State examiner being present?

*Guidance:* Yes. FMCSA's current statutory authorities and regulations do not prohibit States from permitting third party testers to administer CDL knowledge tests. While FMCSA encourages States relying on third party knowledge testers to follow the training and record check standards currently applicable to State CDL knowledge examiners, as set forth in 49 CFR 384.228, this is not a regulatory requirement. If an employee of the State who is authorized to supervise knowledge testing is present during the testing, then FMCSA regards it as being administered by the State and not by a third party.

FMCSA notes that this guidance is intended only to provide clarity to the public regarding existing requirements under the law. The guidance does not have the force and effect of law and is not meant to bind the public in any way.

**Robin Hutcheson,**

*Acting Administrator.*

[FR Doc. 2022-02165 Filed 2-2-22; 8:45 am]

**BILLING CODE 4910-EX-P**

## DEPARTMENT OF THE INTERIOR

### Fish and Wildlife Service

#### 50 CFR Part 17

[Docket No. FWS-R8-ES-2019-0065; FF09E22000 FXES1113090FEDR 223]

RIN 1018-BE11

### Endangered and Threatened Wildlife and Plants; Removing San Benito Evening-Primrose (*Camissonia benitensis*) From the Federal List of Endangered and Threatened Plants

**AGENCY:** Fish and Wildlife Service, Interior.

**ACTION:** Final rule.

**SUMMARY:** We, the U.S. Fish and Wildlife Service (Service or USFWS), are removing San Benito evening-primrose (*Camissonia benitensis*), a plant native to California, from the Federal List of Endangered and Threatened Plants on the basis of recovery. This final rule is based on a thorough review of the best available scientific and commercial information, which indicates that the threats to the species have been reduced or eliminated to the point that it has recovered and is no longer in danger of extinction or likely to become in danger of extinction in the foreseeable future. Therefore, the plant no longer meets the definition of an endangered or threatened species under the Endangered Species Act of 1973, as amended (Act).

**DATES:** This rule is effective March 7, 2022.

**ADDRESSES:** This final rule, the post-delisting monitoring plan, and supporting documents are available on the internet at <https://www.regulations.gov> or at <https://ecos.fws.gov>.

In the Search box, enter FWS-R8-ES-2019-0065, which is the docket number for this rulemaking. Then, click on the Search button. On the resulting page, in the panel on the left side of the screen, under the Document Type heading, click on the Final Rule box to locate this document.

*Document availability:* The recovery plan, 5-year review summary, and post-delisting monitoring plan referenced in this document are available at <https://www.regulations.gov> under Docket No. FWS-R8-ES-2019-0065.

#### FOR FURTHER INFORMATION CONTACT:

Stephen P. Henry, Field Supervisor, U.S. Fish and Wildlife Service, Ventura Fish and Wildlife Office, 2493 Portola Road, Suite B, Ventura, CA 93003; by telephone 805-644-1766. Direct all questions or requests for additional information to: SAN BENITO EVENING PRIMROSE QUESTIONS, to the address above (See **ADDRESSES**). Individuals who are hearing-impaired or speech-impaired may call the Federal Relay Service at 800-877-8339.

#### SUPPLEMENTARY INFORMATION:

##### Executive Summary

*Why we need to publish a rule.* Under the Act, a species may warrant removal (*i.e.*, "delisting") from the Federal List of Endangered and Threatened Plants if it no longer meets the definition of an endangered species or a threatened species. Delisting a species can only be completed by issuing a rule.

*What this document does.* We are removing San Benito evening-primrose (*Camissonia benitensis*) from the Federal List of Endangered and Threatened Plants based on its recovery. The prohibitions and conservation measures provided by the Act, particularly through sections 7 and 9, will no longer apply to the San Benito evening-primrose.

*The basis for our action.* Under the Act, we may determine that a species is an endangered species or a threatened species because of any of five factors: (A) The present or threatened destruction, modification, or curtailment of its habitat or range; (B) overutilization for commercial, recreational, scientific, or educational purposes; (C) disease or predation; (D) the inadequacy of existing regulatory mechanisms; or (E) other natural or

manmade factors affecting its continued existence. We have determined that the threats to the species have been reduced or eliminated so that San Benito evening-primrose no longer meets the definition of an endangered or threatened species under the Act.

Under the Act and our implementing regulations at 50 CFR 424.11, we may delist a species if the best available scientific and commercial data indicate that: (1) The species is extinct; (2) the species does not meet the definition of an endangered species or a threatened species when considering the five factors listed above; or (3) the listed entity does not meet the statutory definition of a species. Here, we have determined that the San Benito evening-primrose should be delisted because, based on an analysis of the five listing factors, it has recovered and no longer meets the definition of an endangered species or a threatened species.

Off-highway vehicle recreation, the greatest persistent threat to the species, has been reduced to levels that no longer pose a significant threat of extinction to San Benito evening-primrose or its habitat. Additionally, the species is more wide-ranging and common than originally known and occurs across a broader range of habitat types (Bureau of Land Management (BLM) 2018, p. 32). The number of known occurrences has increased from 9 to 79; the range of the species is now known from 3 watersheds; and occupied habitat covers 63.2 acres (25.6 ha).

*Peer review and public comment.* We evaluated the species' needs, current conditions, and future conditions to support our June 1, 2020, proposed rule to delist the San Benito evening-primrose (85 FR 33060). We sought comments from independent specialists to ensure that our determination is based on scientifically sound data, assumptions, and analyses. We invited these peer reviewers to comment on the proposed rule and draft post-delisting monitoring plan. We considered all comments and information we received during the public comment period on the proposed rule and the draft post-delisting monitoring plan when developing this final rule.

#### Previous Federal Actions

On February 12, 1985, we listed San Benito evening-primrose as a threatened species (50 FR 5755–5759) based

primarily on the threats from motorized recreation and active gravel mining. Nine occurrences of the plant were known at the time, ranging from only 10 to 100 individuals each (50 FR 5755). At the time of listing, we found that designation of critical habitat was not prudent, and no further action regarding critical habitat has been taken (50 FR 5757–5759).

A notice of the availability of a recovery plan for San Benito evening-primrose was subsequently published on September 19, 2006 (71 FR 54837–54838) (Recovery Plan).

In 2009, the Service conducted a 5-year review (USFWS 2009, entire) and found that the San Benito evening-primrose still met the definition of a threatened species. In addition, we announced the initiation of another 5-year review on June 18, 2018 (83 FR 28251–28254). On June 1, 2020, we proposed to delist the San Benito evening-primrose (85 FR 33060) and announced the availability of a draft post-delisting monitoring plan. The June 1, 2020, proposed rule to remove San Benito evening-primrose from the Federal List of Endangered and Threatened Plants also serves as a 5-year review for the species.

#### Summary of Changes From the Proposed Rule and Post-Delisting Monitoring Plan

We considered all comments and information we received during the comment period for the proposed rule to delist San Benito evening-primrose (85 FR 33060; June 1, 2020). This consideration resulted in the following changes from the proposed rule in this final rule:

- We made minor editorial changes and revised various sections of the rule based on public and partner comments.
- We reevaluated the climate change analysis with a range more specific to San Benito evening-primrose.
- We updated the population trend analysis with current information and following comments from the BLM.
- We updated off-highway vehicle (OHV) trespass information with current data.
- We updated total known occurrences with current data.
- The post-delisting monitoring plan was revised in partnership with the BLM.

#### Final Delisting Determination

##### Background

San Benito evening-primrose is a small, yellow-flowered, annual species in the evening-primrose family (Onagraceae). The plant is slender with narrowly elliptic leaves 0.3 inches (in) (7–20 millimeters (mm)) in length and minutely serrate. The stem may be erect or decumbent (lying on the ground with the extremity curving upward) and ranges in height from 1.2 to 7.9 in (3–20 centimeters (cm)) with branches widely spreading. Petals are 0.1 to 0.2 in (3.5 to 4 mm) and may fade from yellow to reddish (Wagner 2012, pp. 925–929). San Benito evening-primrose is autogamous (self-fertilizing) and produces seed that persists for long periods of time, which creates well-established seed banks where the species occurs (Taylor 1990, pp. 7–8).

San Benito evening-primrose is known only from the southeastern portion of San Benito County, the western edge of Fresno County, and the northeastern edge of Monterey County, largely within the New Idria serpentinite mass (figure 1). Serpentine is a rock formed from ancient volcanic activity that results in minerals with a greenish and brownish appearance such as antigorite, lizardite, and chrysotile. The New Idria serpentinite mass covers approximately 13,000 hectares (32,124 acres) and is one of the largest serpentinite formations in the southern Coast Ranges of California (Rajakaruna et al. 2011, p. 698).

Average rainfall in areas occupied by San Benito evening-primrose is 16–17 in (40–42 cm) annually with temperatures ranging from lows of 21 to 34 degrees Fahrenheit (°F) (–6.7 to –1.1 degrees Celsius (°C)) in the winter to highs of 90 to 100 °F (32.2 to 37.8 °C) in the summer (USFWS 2009, p. 8). San Benito evening-primrose occurs across an elevation range from 1,929 ft (588 m) to 4,684 ft (1,428 m). At the extremes of the elevation range, the minimum precipitation may be as low as 15 in (38 cm) and as high as 20 in (51 cm) respectively (BLM 2020a, pp. 1–2). Occupied habitat of San Benito evening-primrose occurs primarily on land managed by the Bureau of Land Management (BLM) (36.5 acres), as well as on private land (26.6 acres).

BILLING CODE 4333–15–P

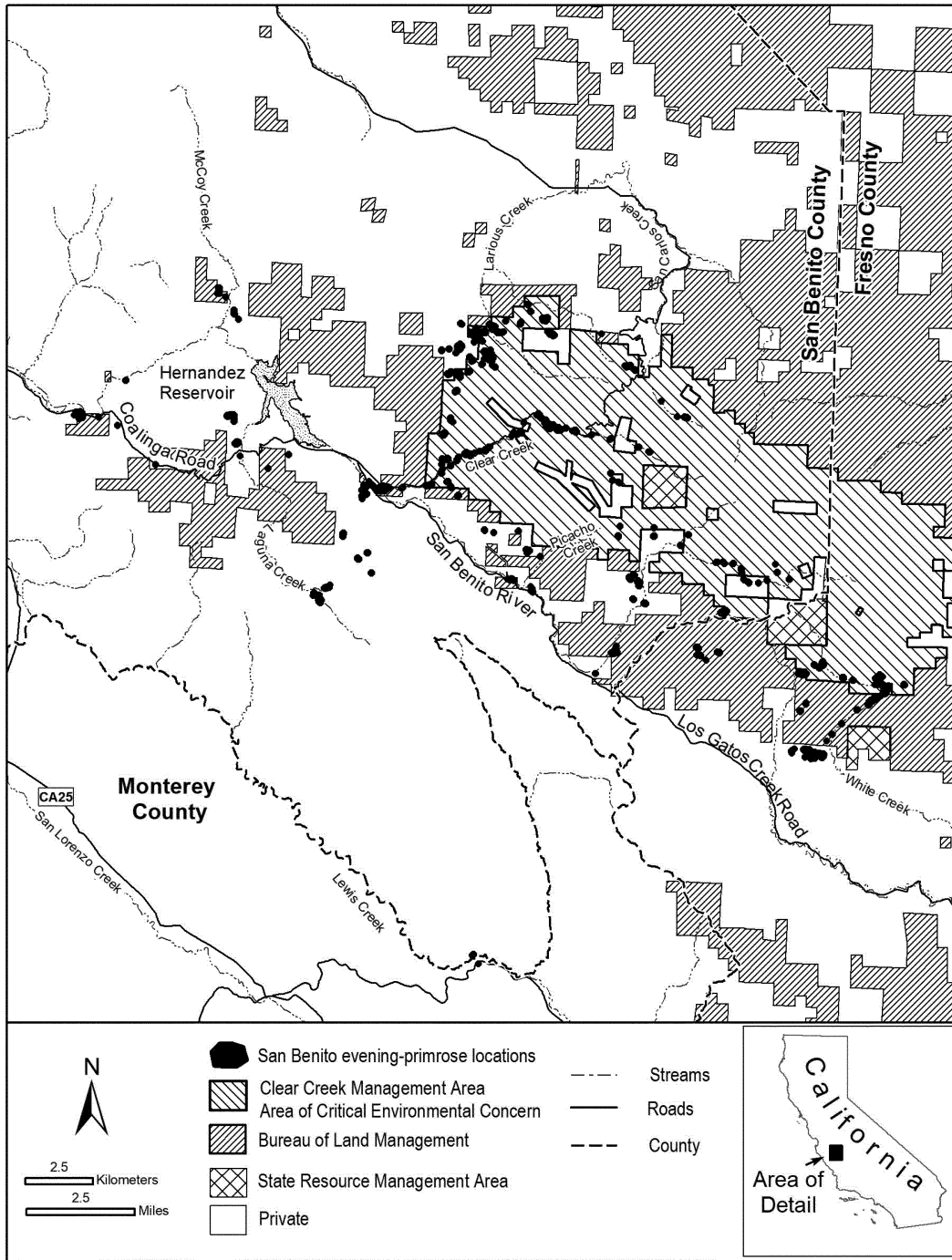

**Figure 1.** Known locations of San Benito evening-primrose with land management identified.

**BILLING CODE 4333-15-C**

San Benito evening-primrose occurs on alluvial terraces and upland geologic transition zones containing sandy to gravelly serpentine derived soil, but may also be found on greywacke, chert, and syenite derived soils (Raven 1969, pp. 332-333, Taylor 1990, pp. 24-36,

39-42, BLM 2018, pp. 17-19). Alluvial terrace habitat is characterized by serpentine soils that are deeper and better developed than neighboring slopes, generally flat (<3 degrees slope), and contain less than 25 percent cover of chaparral or woody vegetation

(Taylor 1990, pp. 69, 71-72, USFWS 2006, p. 13). Geologic transition zone habitat is characterized by sandy soils within uplands on slopes between 15 degrees and 60 degrees as well as rock outcrops and talus (Dick et al. 2014, p. 167, BLM 2018, p. 18). The transition

zone that the habitat type refers to is the boundary between serpentine masses and non-serpentine rock (BLM 2014, pp. 110–112). Generally, alluvial habitat is found closer to water and in association with *Quercus durata* (leather oak), *Arctostaphylos* spp. (manzanita), *Pinus jeffreyi* (Jeffrey pine), *P. sabiniana* (bull pine), and *P. coulteri* (Coulter pine). Geologic transition zone habitat is found far from water and in association with *Q. douglassii* (blue oak), *Juniperus californicus* (California juniper), and *Q. berberidifolia* (scrub oak) (Dick et al. 2014, p. 167).

Within this rule, a single “occurrence” refers to areas where San Benito evening-primrose has been mapped. Mapped areas within 0.25 mi (0.4 km) of each other, but discontinuous, are considered a single occurrence consisting of multiple sub-occurrences. The BLM has recorded point data, in addition to polygon sub-occurrences for San Benito evening-primrose, which are referred to as point locations in this report. Point locations are mapped point features while sub-occurrences are mapped polygon features.

The BLM first identified the geologic transition zone habitat type in 2009 through surveys of potential habitat and known occurrences of San Benito evening-primrose. The discovery of the new habitat type, and associated new occurrences, increased the number of known point locations from 69 in 2009 to 666 in 2020 (BLM 2020b, p. 25). The difference between geologic transition zone habitat and alluvial terrace habitat

suggested the possibility that there were two genetically distinct lineages of San Benito evening-primrose or that the species may be hybridizing with the close relatives plains evening primrose (*C. contorta*) and sandy soil suncup (*C. strigulosa*). However, it was determined that hybridization was not occurring and that watersheds and habitat type did not explain any genetic differences that were identified (Dick et al. 2014, entire). The findings indicate that the known occurrences of San Benito evening-primrose are all part of the same genetic population (Dick et al. 2014, entire).

The BLM has been conducting surveys for San Benito evening-primrose since 1980 within the Clear Creek Management Area, where the majority of sub-occurrences are located. The surveys conducted by the BLM have resulted in an increase in the understanding of the range of the species, habitat preferences, life history, and numbers (BLM 2018, entire). The monitoring has resulted in the identification of 666 point locations occurring within and outside of the boundary of the Clear Creek Management Area (CCMA), including a substantial number on private land (7 known point locations in 2009 and 287 known point locations in 2020) (BLM 2020b, p. 25).

The species’ current known range is bordered on the north by New Idria Road near the confluence of Larious Creek and San Carlos Creek, to the South at the Monterey County Line near Lewis Creek, to the west near the

Hernandez Reservoir, and to the east by the eastern boundary of the serpentine area of critical environmental concern (ACEC), an area of approximately 307 square miles. The BLM’s ACEC designations highlight areas where special management attention is needed to protect important historical, cultural, and scenic values, or fish and wildlife or other natural resources. ACECs can also be designated to protect human life and safety from natural hazards. The known occurrences cover 64 ac (26 ha) of public and private land, and potential suitable habitat is currently estimated at 260 ac (105 ha) (BLM 2018, p. 31).

The findings of the BLM have been documented in annual reports from 2009 to 2020 and are the source of the most recent information regarding the status of the occurrences of San Benito evening-primrose. In response to the proposed rule, the BLM provided additional information regarding the effects of climate change, woody vegetation dynamics, habitat recolonization, photopoint monitoring, and life-history information (BLM 2020a, BLM 2020c, BLM 2020d, BLM 2020e, BLM 2020f).

This final determination incorporates data provided by the BLM within the 2018 and 2020 Annual Report (BLM 2018, entire, BLM 2020b, entire) as well as the supplemental information provided in response to the proposed rule. In 2020, 79 occurrences, consisting of 519 sub-occurrences, and 666 point locations were mapped by the BLM (table 1) (BLM 2018, spatial data, BLM 2020b, pp. 10–22).

TABLE 1—2020 BLM SURVEY RESULTS

	Number of occurrences	Number of sub-occurrences	Number of point locations	Acres (hectares)
2020 San Benito evening-primrose ( <i>Camissonia benitensis</i> ) survey results .....	79	519	666	63.2 (25.6)

Occurrences consist of sub-occurrences (mapped polygons) within 0.25 mile of each other. Point locations are reported in the 2020 Annual Report (BLM 2020 p. 25). Acreage data are derived from the spatial extent of the mapped occurrences.

The BLM compared historical occurrence data to their point location counts in their annual reports, which we used in the Recovery Plan (USFWS 2006, entire) and 5-year review (USFWS 2009, entire). Here, we have chosen to update the occurrence organization because the numbers of occurrences, sub-occurrences, and point locations have increased dramatically since 2009. Table 1 illustrates the relationship between occurrences, sub-occurrences, and point locations. Occurrence contains sub-occurrences and point locations. Sub-occurrences contain point locations, and point locations

have no further break down. When possible, we use the same terminology as previous reports.

**Recovery and Recovery Plan Implementation**

Section 4(f) of the Act directs us to develop and implement recovery plans for the conservation and survival of endangered and threatened species unless we determine that such a plan will not promote the conservation of the species. Under section 4(f)(1)(B)(ii), recovery plans must, to the maximum extent practicable, include objective, measurable criteria which, when met,

would result in a determination, in accordance with the provisions of section 4 of the Act, that the species be removed from the List.

Recovery plans provide a roadmap for us and our partners on methods of enhancing conservation and minimizing threats to listed species, as well as measurable criteria against which to evaluate progress towards recovery and assess the species’ likely future condition. However, they are not regulatory documents and do not substitute for the determinations and promulgation of regulations required under section 4(a)(1) of the Act. A



decision to revise the status of a species, or to delist a species, is ultimately based on an analysis of the best scientific and commercial data available to determine whether a species is no longer an endangered species or a threatened species, regardless of whether that information differs from the recovery plan.

There are many paths to accomplishing recovery of a species, and recovery may be achieved without all of the criteria in a recovery plan being fully met. For example, one or more criteria may be exceeded while other criteria may not yet be accomplished. In that instance, we may determine that the threats are minimized sufficiently and that the species is robust enough that it no longer meets the definition of an endangered species or a threatened species. In other cases, we may discover new recovery opportunities after having finalized the recovery plan. Parties seeking to conserve the species may use these opportunities instead of methods identified in the recovery plan. Likewise, we may learn new information about the species after we finalize the recovery plan. The new information may change the extent to which existing criteria are appropriate for identifying recovery of the species. The recovery of a species is a dynamic process requiring adaptive management that may, or may not, follow all of the guidance provided in a recovery plan.

Below, we summarize the recovery plan goals and discuss progress toward meeting the recovery objectives and how they inform our analysis of the species' status and the stressors affecting it.

The Recovery Plan (USFWS 2006, pp. 48–74) describes the recovery goal and criteria that need to be achieved in order to consider delisting San Benito evening-primrose. We summarize the goal and then discuss progress toward meeting the recovery criteria in the following sections.

#### *Recovery Goal*

In the Recovery Plan, the stated goal is to restore occurrences of San Benito evening-primrose so that they are self-sustaining and protected from future threats (USFWS 2006, p. 51). This goal is broadly evaluated through trends in the observed numbers of individuals indicated by annual monitoring, the abundance and distribution of suitable habitat, evaluation of the seed bank, and the effectiveness of protective measures that have been implemented to reduce threats from human activities such as mining, OHV use, and other recreational activity (USFWS 2006, pp. 51–52). In

order to determine if a species meets the definition of a threatened species, we must consider potential impacts within the foreseeable future. The Recovery Plan (USFWS 2006, entire) used 20 years as the period of time to evaluate population stability because the number of individuals fluctuates widely from year to year and a longer monitoring time will better reflect changes in trends despite this variation (USFWS 2006, pp. 51, 53). Given this and information on potential threats into the future, in this final rule we have adopted 20 to 30 years as the foreseeable future to evaluate potential threats and the species' responses to those threats.

#### *Recovery Criteria*

The Recovery Plan identified five criteria for delisting the San Benito evening-primrose (USFWS 2006, pp. 52–54):

(1) Research has evaluated the possibility for restoration of suitable habitat and the natural rate of the replacement of suitable habitat (*i.e.*, succession from open habitat to woody vegetation), the ecology of the seedbank, and population viability modeling. The results of completed research, and any other research that was conducted, should inform all other recovery criteria suggested by the Recovery Plan and are listed below.

(2) Known occurrences and sufficient additional suitable habitat within each watershed unit throughout its range are protected from direct effects from OHV use and other recreational activities. Appropriate levels of compliance with use regulations by recreationists have prevented adverse impacts to San Benito evening-primrose occurrences and habitat.

(3) Currently occupied and suitable habitat for the species has been restored and maintained over an appropriate period of time, as informed by monitoring and research. Twenty years was estimated as “the appropriate period of time” in the Recovery Plan (USFWS 2006, p. 53). The Recovery Plan emphasizes maintaining suitable habitat and more precisely defining the requirements of suitable habitat. Additionally, disturbance and erosion rates should not be elevated above natural levels and the seed bank should be evaluated for continued persistence, as above-ground numbers of individuals are known to fluctuate widely from year to year.

(4) Population sizes have been maintained over a monitoring period that includes multiple rainfall cycles (successive periods of drought and wet years). The Recovery Plan states that the trend of above-ground counts of species

should be stable or increasing and defines non-drought years as those with greater than 15 in (38 cm) of rainfall from October through April at the Priest Valley weather station.

(5) A post-delisting monitoring plan for San Benito evening-primrose has been developed.

#### *Achievement of Recovery Criteria*

*Criterion 1:* Research has been completed.

Research to increase the understanding of the extent of existing occurrences, the range of suitable habitat, the persistence of the seed bank, and analysis of the genetic variability across watersheds and habitat types has been undertaken since listing in 1985 (Taylor 1990, entire; BLM 2010, entire; BLM 2014, entire; BLM 2015, entire; BLM 2018, entire; Dick et al. 2014, entire).

*Habitat Suitability.* Research conducted in 1990 (Taylor 1990, entire) provided the first comprehensive overview of the ecology of San Benito evening-primrose that established the initial understanding for the requirements of suitable habitat for the species, the species' life history, including early examination of the seed bank and germination characteristics, and the known distribution of the species as well as threats to the known occurrences. From 1990 through 2010, San Benito evening-primrose was thought to be restricted to alluvial terrace habitat that was characterized by relatively deep and well-developed, serpentine-derived soils on flat ground (compared to nearby barren serpentine slopes), association with ephemeral or intermittent streams, and open habitat lacking woody vegetation (Taylor 1990, pp. 39–40). In 2010, the BLM identified a second type of habitat, termed the “geologic transition zone,” that was suitable for San Benito evening-primrose (BLM 2010, pp. 8–16). The geologic transition zone was characterized by relatively steeper slopes (0–60 degrees) of uplands on serpentine soils at the interface with non-serpentine soils. Geologic transition zone habitat is not topographically constrained to the toe of slopes, whereas alluvial stream terrace habitat is.

From the time of listing through 2018, the BLM conducted extensive surveys within these habitat types, which led to the discovery and documentation of more than 600 new point locations. The results indicated that the majority of both occupied and potential habitat is greatest within the geologic transition zone type (BLM 2018, p. 32). The new sub-occurrences identified within the geologic transition zone habitat are

relatively undisturbed in comparison to the highly disturbed sites of the initial locations known from alluvial stream terraces (BLM 2010, p. 11). The majority of new point locations are found outside of the historical areas used by OHVs and as a result have not been subjected to the same levels of disturbance.

Approximately one-third to half of the currently known occurrences exist on private land outside of the Clear Creek Management Area (table 2, table 3) (BLM 2018, p. 33).

*Seed Bank Analysis.* Our understanding of the role of the seed bank in the life history of San Benito evening-primrose has similarly increased due to research efforts. The number of viable seeds within the seed bank was often many times greater than the above-ground expression in any given year—including those years in which there was a large above-ground expression (Taylor 1990, p. 57). The size of the seed bank at existing locations was reevaluated in 2010 by the BLM (BLM 2011, pp. 36–42). The BLM found that there were 519 times as many seeds as emergent plants when averaged across 67 sub-occurrences in 2010, emphasizing that the size of the seedbank is much greater than the total number of observed individuals in a given year. Maintaining a large amount of seed within the soil is a common strategy for short-lived annuals in habitats with frequent disturbance because the persistent seed bank buffers against stochastic environmental events such as drought (Kalisz and McPeck 1993, pp. 319–320; Fischer and Matthies 1998, pp. 275–277; Adams et al. 2005, p. 434). In species that develop large seed banks, it is common to see no above-ground expression one year and to see a large expression the following year, and this pattern has been well-documented with San Benito evening-primrose (BLM 2018, p. 11).

*Disturbance Ecology.* Frost heaving (the expansion and contraction of water within the soil during freeze-thaw cycles), small mammal soil disturbance (e.g., gopher burrowing), sediment movement from adjacent slopes, and erosion from stream flows were identified as the primary sources of natural disturbance experienced by San Benito evening-primrose (Taylor 1990, pp. 39–42, 57). In response to the proposed rule, the BLM developed severity tables for natural and anthropogenic sources of disturbance (BLM 2020c, pp. 24–26). While San Benito evening-primrose tolerates, and is adapted to, disturbance from natural processes, anthropogenic disturbances from activities such as mining, road and building construction, and OHV use are much more severe and may lead to loss of habitat through soil removal, soil compaction, and increased rates of erosion (BLM 2010, p. 29, Snyder et al. 1976, pp. 29–30, Brooks and Lair 2005, p. 7, pp. 130–131, Lovich and Bainbridge 1999, pp. 315–317, Switalski et al. 2017, p. 88).

San Benito evening-primrose occurs in areas where the disturbance regime is intermediate between two extremes of not enough disturbance and too much disturbance. The disturbance regime may be viewed as a combination of the frequency of disturbance and the intensity of disturbance. Too little disturbance results in increased competition from woody vegetation that negatively affects San Benito evening-primrose occurrences. Conversely, high levels of disturbance results in direct mortality and loss of seed bank (BLM 2020c, entire). Alluvial terrace habitat that was greater than 50 percent disturbed from OHV use was considered to be unsuitable for San Benito evening-primrose (Taylor 1990, p. 71; USFWS 2006, p. 13). Geologic transition zone habitat was not considered here because it had not yet been recognized as

suitable habitat, but tends to have less OHV disturbance than alluvial terrace habitat. The seed bank of San Benito evening-primrose is very large, and the amount of seed present is many times greater than the amount of individuals that germinate in any given year (Taylor 1990, p. 57, BLM 2011, pp. 33–42). Additionally, the BLM found that the majority of the existing seed bank is found within the top 1 to 3 in (4 to 8 cm) of soil (BLM 2013, pp. 19–34). As a result, any damage to, or loss of, the top layer of soil has the potential to negatively affect the ability of the species to persist through time.

*Population Trends.* The Recovery Plan recommends target numbers of individuals for a subset (27) of the known occurrences of San Benito evening-primrose (USFWS 2006, pp. 56–58). These occurrences also generally have the longest record of survey data and include the initial occurrences described in Taylor (1990, entire). Consistent data collection of all 27 of these occurrences began in 1998. Although data for some occurrences is available from 1983, the current population trend analysis uses 1998 as a starting point in order to keep the total number of occurrences per year the same, thereby allowing comparisons across years. Data from the BLM indicate that the number of individuals observed annually at these occurrences has varied around a mean of approximately 9,690 individuals (figure 2). The 5-year moving average indicates a slightly oscillating but generally stable trend in the average number of individuals from 1998 through 2020. Alternative analyses of the data using either more years of historical data and/or more occurrences have all concluded relatively similar results suggesting that the population is stable (85 FR 33060, BLM 2020g, entire).

**BILLING CODE 4333-15-P**



**Figure 2.** Total number of individuals observed at 27 occurrences of San Benito evening-primrose (*C. benitensis*) within the Clear Creek Management Area from 1998 through 2020. The solid line shows the annual total, while the hashed line shows the 5-year moving average. The dotted line shows a linear fit of the annual total data. Note that the y-axis is on a log scale.

**BILLING CODE 4333-15-C**

**Population Genetics.** The occurrences of San Benito evening-primrose found within geologic transition zone habitat were at first thought to be genetically distinct from occurrences within alluvial terrace habitat. The new occurrences were also located within different watersheds from the first known occurrences, and there was some question as to whether or not the species may be hybridizing with a close relative, *Camissonia strigulosa* (contorted primrose). If the occurrences were genetically distinct, recovery actions, such as restoration of degraded habitat and out-planting efforts, would need to be identified for each habitat type. There were three distinct genetic clusters of San Benito evening-primrose found, but none of the genetic clusters coincided with type of habitat or watershed (Dick et al. 2014, entire). Additionally, the same study found no evidence of hybridization between San Benito evening-primrose and contorted primrose. Because the genetic diversity identified within the occurrences was widespread and uncorrelated with habitat and watershed, future out-planting efforts would not need to be restricted to genetic type. The study instead concluded that seed from different occurrences should be mixed

to increase diversity across the entire geographic range.

In summary, research to increase the understanding of the extent of existing occurrences, the range of suitable habitat, the persistence of the seed bank, and analysis of the genetic variability across watersheds and habitat types have been undertaken fulfilling recovery criterion 1.

**Criterion 2:** Known occurrences and sufficient additional suitable habitat within each watershed unit throughout its range are protected from direct effects from OHV use and other recreational activities.

Wire fencing, steel pipe barriers, signage, and enforcement of trail restrictions were used to protect San Benito evening-primrose and suitable habitat prior to the 2006 amendment to the Resource Management Plan. The 2006 amendment to the Resource Management Plan closed to OHVs all areas not marked for limited or open use. This restricted the total OHV use area to 242 miles (390 km) of OHV trails and directed OHV use away from areas that provided suitable habitat for, or were occupied by, San Benito evening-primrose (BLM 2006 p. 3-1). By 2009, non-compliance with the 2006 Resource Management Plan had declined (BLM 2008, pp. 5-9; USFWS 2009, pp. 19-21).

In 2008, the EPA issued a report concluding that exposure to naturally occurring asbestos during recreational activities, including OHV use, was higher than the acceptable risk range for causing cancer within the CCMA (Environmental Protection Agency (EPA) 2008, p. 6-3). The level of exposure to asbestos varied with recreational activity and participant age, but was significant enough to warrant an emergency temporary closure of the CCMA (BLM 2008, p. 2). Although not the intent, the closure effectively temporarily protected all known occurrences of San Benito evening-primrose from OHV disturbance. The temporary closure remained in place until the 2014 amendment to the Resource Management Plan was adopted (BLM 2014, entire). The 2014 Resource Management Plan further restricted OHV access to areas of suitable habitat and known sub-occurrences of San Benito evening-primrose by reducing the amount of open trails and restricting access to the Serpentine ACEC to 5 days per year per recreationalist through a permit system and a series of locked gates (BLM 2014, pp. 1-18).

The BLM has conducted OHV non-compliance monitoring as part of the annual San Benito evening-primrose

surveys since 2008 and the initial closure of the Serpentine ACEC (table 2). During this time, non-compliance has remained relatively low with the number of point locations or potential habitat being impacted by OHV ranging from 2 to 11 locations in a given year. The amount of disturbance within each

area has been observed to be low, and natural recovery was observed. Upper Clear Creek, Larious Canyon, and San Carlos Creek are areas of repeated non-compliance despite annual repairing of fencing and barriers and issuance of citations for violating the closures when users are caught (BLM 2013, p. 5, BLM

2015, p. 6, BLM 2020b, pp. 7–8). The intensity of non-compliance varied from heavy (greater than 10 tracks observed) to moderate or low (less than 10 tracks observed). The BLM assumes that non-compliant OHV use originates from private land adjacent to the CCMA.

TABLE 2—SUMMARY OF OFF-HIGHWAY VEHICLE NON-COMPLIANCE WITHIN THE SERPENTINE AREA OF CRITICAL ENVIRONMENTAL CONCERN 2008 THROUGH 2020

Year*	Number of point locations with observed non-compliance	Minimum number of tracks	Maximum number of tracks	Average number of tracks	Reference
2008	6	NA	NA	NA	BLM 2008 pp. 8–9.
2009	3	NA	NA	NA	BLM 2010 p. 5.
2010	2	2	10+	2	BLM 2011 pp. 12–13.
2012	11	1	10+	7	BLM 2012 p. 5.
2013	10	1	10+	8	BLM 2013 p. 5.
2014	9	1	10+	5	BLM 2015 p. 6.
2015	8	1	10+	7	BLM 2017 pp. 6–7.
2016	6	1	10+	8	BLM 2017 p. 8.
2020	12	1	10+	8	BLM 2020b pp. 7–8.

\* No data available for 2011, 2017, 2018. Minimum, maximum, and average number of tracks observed were not available for the 2008 and 2009 survey seasons.

By 2014, the number of known point locations of San Benito evening-primrose had grown to 500 with the majority occurring within the geologic transition zone habitat. Approximately half of those locations were protected from OHV use due to the restrictions imposed by the 2014 Resource Management Plan (BLM 2014, pp. 1–18; BLM 2015, pp. 7–16). By 2020, 666 point locations of San Benito evening-primrose had been mapped by the BLM (BLM 2020b, p. 25). The 666 point locations correspond to 79 occurrences consisting of 519 sub-occurrences and covering 63.2 acres (25.6 ha) (table 1, figure 1). Twenty-three occurrences (81

sub-occurrences) are located within the Serpentine ACEC and are effectively protected from OHV use due to the 2014 Resource Management Plan (BLM 2018, p. 33) (table 3). There are 36 occurrences (260 sub-occurrences) within BLM-managed land outside of the Serpentine ACEC. OHV use within the CCMA, but outside of the Serpentine ACEC, has been designated as “limited,” meaning that motorized use is restricted to highway-licensed vehicles and ATVs and utility task vehicles on designated routes only (BLM 2014, pp. 1–13–14). Forty-five occurrences (178 sub-occurrences) are known to occur on private land that is not subject to

management by the BLM or other Federal agencies (table 3, table 4).

When the Recovery Plan criteria were written, there were 27 known occurrences: 23 were on land managed by the BLM, and 4 were on private property. Currently, there are 59 occurrences on BLM-managed land and 45 occurrences on private property. Protections for the occurrences on private land cannot be guaranteed; however, the occurrences on BLM lands are managed to protect San Benito evening-primrose from OHV use and other recreational activities.

TABLE 3—NUMBER OF OCCURRENCES, SUB-OCCURRENCES, AND ACREAGE OF MAPPED SAN BENITO EVENING-PRIMROSE (CAMISSONIA BENITENSIS) LOCATIONS BY LAND MANAGER

	Number of occurrences	Number of sub-occurrences	Acres
BLM	36	260	23.8
ACEC	23	81	12.7
Private	45	178	26.6

Occurrences consist of sub-occurrences (mapped polygons) within 0.25 mile of each other. Point locations are reported in the 2020 Annual Report (BLM 2020b p. 25). Acreage data are derived from the spatial extent of the mapped occurrences. Note that occurrences that encompass multiple property owners may be counted twice because of how the mapped data are nested.

The majority of the known occurrences and sub-occurrences occur within the geologic transition zone identified by the BLM as habitat in 2010 (table 4). Occurrences of San Benito evening-primrose within geologic transition zone habitat are assumed to

be less likely to be affected by OHV recreation since OHV riders have historically preferred the terrain associated with alluvial terrace habitat (BLM 2010, p. 11). In summary, known occurrences and sufficient additional suitable habitat within each watershed

unit throughout its range are protected from direct effects from OHV use and other recreational activities, fulfilling recovery criterion 2.

TABLE 4—NUMBER OF KNOWN OCCURRENCES AND SUB-OCCURRENCES BY LAND MANAGER AND HABITAT TYPE

	Alluvial terrace habitat			Geologic transition zone habitat		
	Number of occurrences	Number of sub-occurrences	Acres	Number of occurrences	Number of sub-occurrences	Acres
BLM .....	17	104	6.7	19	156	17.2
ACEC .....	6	37	3.0	17	44	9.7
Private .....	10	26	0.6	35	152	26.0
Total .....	33	167	10.3	71	352	53.0

Occurrences consist of sub-occurrences (mapped polygons) within 0.25 mile of each other. Point locations are reported in the 2020 Annual Report (BLM 2020b p. 25). Acreage data are derived from the spatial extent of the mapped occurrences. Note that occurrences that encompass multiple property owners may be counted twice because of how the mapped data are nested.

*Criterion 3:* Currently occupied and suitable habitat for the species has been restored and maintained over an appropriate period of time, as informed by monitoring and research.

In the Recovery Plan, 20 years was identified as the appropriate period of time to conduct and evaluate the success of restoration activities. Twenty years was chosen to allow enough time for observations of natural and restored occurrences during non-drought years to be made in order to evaluate the stability of San Benito evening-primrose occurrences (USFWS 2006, pp. 53–54). Thirty-three years have passed since San Benito evening-primrose was listed by the Service as a threatened species. Restoration began prior to listing by using fencing to discourage disturbance by OHVs (Taylor 1990, pp. 24–36, 71). The BLM has continued to implement passive restoration measures such as installation of additional wire fencing and steel pipe barriers to reduce OHV trespass and signage to promote awareness of the natural resources (BLM 2018 pp. 50–56). Photopoint monitoring has demonstrated an increase in the amount of woody vegetation cover in previously open and disturbed areas. The increase in woody vegetation cover suggests that fencing and other barriers have been effective in reducing ground disturbance from OHV use prior to the temporary closure in 2008 and the permanent restrictions in 2014 (BLM 2020e, entire).

Seed of San Benito evening-primrose was introduced between 1990 and 1991 at six areas near existing point locations. At 5 of the reintroduction sites, 30,000 seeds were broadcast into areas that were each 2,153 ft<sup>2</sup> (200–300 m<sup>2</sup>) in area. Sixty thousand seeds were broadcast into the sixth site (BLM 2013, Excel data; Taylor 1993, p. 14). Very few plants, relative to the amount of seed reintroduced, were observed (between 3 and 147 plants) in the years immediately following the seeding. The results of early seed introductions indicate that San Benito evening-

primrose establishment from artificially sown seed is very low (Taylor 1993, p. 14). One area where seed was introduced, that did not previously have extant populations, has continued to have small numbers of individuals observed each year. The establishment of San Benito evening-primrose in an area where it did not previously occur, despite low numbers of individuals relative to number of seed introduced, led to the recommendation that seed introductions should be used as a tool for San Benito evening-primrose conservation and recovery (Taylor 1995, p. 7). Approximately 3,000 seeds were sown in 2008 and 2012 in areas where San Benito evening-primrose had not been observed but where potential habitat existed that could support new occurrences. The number of individuals at these areas have remained similarly low ranging from 0 to 320 individuals in a single year (BLM 2018, pp. 34–47).

Restoration of five staging areas located on stream terraces that were heavily degraded from OHV use and mining (prior to 1939) was completed in 2010 (BLM 2011, pp. 4–10). The staging areas were characterized by a mix of lack of vegetation, soil compaction, buried original soil surface, debris from facilities, and erosion on adjacent hillslopes. A total of 2.01 ac (0.81 ha) of San Benito evening-primrose habitat was restored. The BLM estimated that San Benito evening-primrose may recolonize restored areas within 5 years when seed is introduced following restoration. If seed is not added, recolonization through natural dispersal may take up to several decades (BLM 2020d, pp. 3–4). Annual counts of San Benito evening-primrose at each of the staging areas and associated sub-occurrences have indicated that the number of individuals in any given year fluctuates greatly (BLM 2018, pp. 34–47). Staging areas 1, 4, and 5 have relatively stable annual counts, while staging areas 2 and 3 have had more variable, and possibly slightly declining, annual counts.

The BLM has also undertaken efforts to improve watershed quality by identifying the most appropriate species and methods to restore streambanks (BLM 2011, pp. 10–12). While the immediate stream banks are not suitable habitat for San Benito evening-primrose, restoring natural hydrology and maintaining bank composition can reduce sedimentation and erosion in the watershed that indirectly supports the persistence of San Benito evening-primrose habitat. The BLM found that revegetation of degraded streambanks using sod of *Agrostis exarata* (spike bentgrass) was most effective. Additionally, six vehicle routes were closed and restored by removing access and ripping the compacted soil (BLM 2011 p. 10).

In summary, currently occupied and suitable habitat for the species has been restored and maintained over an appropriate period of time, as informed by monitoring and research, fulfilling recovery criterion 3.

*Criterion 4:* Population sizes have been maintained over a monitoring period that includes multiple rainfall cycles (successive periods of drought and wet years).

The Recovery Plan recommended a target average number of individuals for 27 occurrences of San Benito evening-primrose (USFWS 2006, pp. 54–58). The target counts were based on past observations of the number of individuals observed during favorable years and were considered to be approximate. Four of the 27 locations with a target number of individuals had an average annual count that met or exceeded the target levels between 1983 and 2017 (USFWS 2006, pp. 56–58; BLM 2018, pp. 34–35; USFWS Review of BLM reporting data). Five of the 27 locations had an annual average count that met or exceeded the target number of individuals when only years with normal precipitation are considered. We consider the average number of individuals because the number of individuals at any given site fluctuate

greatly from year to year causing single year counts to be inaccurate measures of the stability of the species (figure 2).

The total annual number of individuals for the same 27 sites has fluctuated around a mean of approximately 9,690 individuals since 1998 (Figure 2). The total number of individuals appears stable over time. The 5-year moving average suggests a stable number of individuals from 1998 to 2020. Although the target numbers have not been met for most of the 27 occurrences known at the time of the 2006 Recovery Plan, the Service determines that the recovery criterion is met because the number of individuals in those occurrences has remained stable around a 5-year moving average, and the number of occurrences has increased (population size has increased). Evaluating the trend of each of the 79 occurrences (666 point locations, see table 1) is not feasible because census data for the entirety of known point locations are not available.

The target number of individuals has not been met for 23 of the 27 occurrences with target criteria. However, the target numbers were estimates and the lack of a consistent decline in total annual counts suggest that, while the occurrences are not increasing in abundance of San Benito evening-primrose, they are not threatened with extinction. The lack of decline in number of individuals over a 27-year monitoring period and an increase in the number of known occurrences indicate that the criteria of maintaining population numbers over an appropriate period of time has been met.

*Criterion 5:* A post-delisting monitoring plan for the species has been developed.

Section 4(g)(1) of the Act requires us, in cooperation with the States, to implement a system to monitor effectively, for not less than 5 years, all species that have been recovered and delisted (50 CFR 17.11, 17.12). The purpose of this post-delisting monitoring is to verify that a species remains secure from risk of extinction after it has been removed from the protections of the Act. The monitoring is designed to detect the failure of any delisted species to sustain itself without the protective measures provided by the Act. If, at any time during the monitoring period, data indicate that protective status under the Act should be reinstated, we can initiate listing procedures, including, if appropriate, emergency listing under section 4(b)(7) of the Act. Section 4(g) of the Act explicitly requires us to cooperate with the States in development and

implementation of post-delisting monitoring programs, but we remain responsible for compliance with section 4(g) and, therefore, must remain actively engaged in all phases of post-delisting monitoring. A post-delisting monitoring plan has been developed by the Service with input from the BLM, the sole Federal entity that manages land where San Benito evening-primrose occurs. Therefore, this criterion has been met.

#### *Summary of Recovery Criteria*

Based on the best available information, we conclude that the recovery criteria in the Recovery Plan have been achieved and the recovery goal identified in the Recovery Plan has been met for San Benito evening-primrose. Recovery criterion 1 has been met with research to increase the understanding of the extent of existing occurrences, the range of suitable habitat, the persistence of the seed bank, and analysis of the genetic variability across watersheds and habitat types. Recovery criterion 2 has been met with protection of known occurrences and sufficient additional suitable habitat within each watershed unit throughout its range. Recovery criteria 3 and 4 have been met through the closure of the Serpentine ACEC, restoration of degraded areas, and observed stability of 27 of the 79 occurrences over a period that included 18 years of normal rainfall over a 27-year period. Recovery criterion 5 has been met through the development of a post-delisting monitoring plan for the species in partnership with the BLM.

### **Regulatory and Analytical Framework**

#### *Regulatory Framework*

Section 4 of the Act (16 U.S.C. 1533) and its implementing regulations (50 CFR part 424) set forth the procedures for determining whether a species is an “endangered species” or a “threatened species,” reclassifying species, or removing species from listed status. The Act defines an endangered species as a species that is “in danger of extinction throughout all or a significant portion of its range,” and a threatened species as a species that is “likely to become an endangered species within the foreseeable future throughout all or a significant portion of its range.” The Act requires that we determine whether any species is an “endangered species” or a “threatened species” because of any of the following factors:

(A) The present or threatened destruction, modification, or curtailment of its habitat or range;

(B) Overutilization for commercial, recreational, scientific, or educational purposes;

(C) Disease or predation;

(D) The inadequacy of existing regulatory mechanisms; or

(E) Other natural or manmade factors affecting its continued existence.

These factors represent broad categories of natural or human-caused actions or conditions that could have an effect on a species’ continued existence. In evaluating these actions and conditions, we look for those that may have a negative effect on individuals of the species, as well as other actions or conditions that may ameliorate any negative effects or may have positive effects. We must consider these same five factors in delisting a species. We may delist a species according to 50 CFR 424.11(d) if the best available scientific and commercial data indicate that the species is neither endangered nor threatened for the following reasons: (1) The species is extinct; (2) the species does not meet the definition of an endangered species or a threatened species when considering the five factors listed above; or (3) the listed entity does not meet the statutory definition of a species. The same factors apply whether we are analyzing the species’ status throughout all of its range or a significant portion of its range.

We use the term “threat” to refer in general to actions or conditions that are known to or are reasonably likely to negatively affect individuals of a species. The term “threat” includes actions or conditions that have a direct impact on individuals (direct impacts), as well as those that affect individuals through alteration of their habitat or required resources (stressors). The term “threat” may encompass—either together or separately—the source of the action or condition or the action or condition itself.

However, the mere identification of any threat(s) does not necessarily mean that the species meets the statutory definition of an “endangered species” or a “threatened species.” In determining whether a species meets either definition, we must evaluate all identified threats by considering the expected response by the species, and the effects of the threats—in light of those actions and conditions that will ameliorate the threats—on an individual, population, and species level. We evaluate each threat and its expected effects on the species, then analyze the cumulative effect of all of the threats on the species as a whole. We also consider the cumulative effect of the threats in light of those actions

and conditions that will have positive effects on the species, such as any existing regulatory mechanisms or conservation efforts. The Secretary determines whether the species meets the definition of an “endangered species” or a “threatened species” only after conducting this cumulative analysis and describing the expected effect on the species now and in the foreseeable future.

The Act does not define the term “foreseeable future,” which appears in the statutory definition of “threatened species.” Our implementing regulations at 50 CFR 424.11(d) set forth a framework for evaluating the foreseeable future on a case-by-case basis. The term “foreseeable future” extends only so far into the future as the Services can reasonably determine that both the future threats and the species’ responses to those threats are likely. In other words, the foreseeable future is the period of time in which we can make reliable predictions. “Reliable” does not mean “certain”; it means sufficient to provide a reasonable degree of confidence in the prediction. Thus, a prediction is reliable if it is reasonable to depend on it when making decisions.

It is not always possible or necessary to define foreseeable future as a particular number of years. Analysis of the foreseeable future uses the best scientific and commercial data available and should consider the timeframes applicable to the relevant threats and to the species’ likely responses to those threats in view of its life-history characteristics. Data that are typically relevant to assessing the species’ biological response include species-specific factors such as lifespan, reproductive rates or productivity, certain behaviors, and other demographic factors. For San Benito evening primrose, we examined the impacts of the threats out to 2050 based on our climate change assessment so our foreseeable future is projected out approximately 30 years.

#### *Analytical Framework*

The 5-year review documents the results of our comprehensive biological status review for the species, including an assessment of the potential threats to the species. The review provides the scientific basis that informs our regulatory decisions, which involve the further application of standards within the Act and its implementing regulations and policies. The 5-year review can be found at <https://www.regulations.gov> under Docket FWS-R8-ES-2019-0065. Where information in the 5-year review is out

of date, we have provided updated information in this final rule.

#### **Summary of Biological Status and Threats**

Historical analyses and discussion of the threats to San Benito evening-primrose are detailed in the Recovery Plan (USFWS 2006, pp. 26–36) and 5-year review (USFWS 2009, pp. 10–18). An updated analysis and discussion follow here. Primary threats to San Benito evening-primrose identified in the listing rule included OHV use of occupied and potential habitat and gravel mining. Uncertainty about the reproductive capacity of the species and vandalism were also considered additional threats at listing. Vandalism was considered a threat due to the small population size and public resistance to listing the species under the Act. The resistance came from the OHV community perception that listing the species would inhibit their ability to continue recreating. However, vandalism was not believed to be significant with subsequent reviews of the species in the Recovery Plan and 5-year review and is not considered further in this final rule. Since listing, the Recovery Plan and 5-year review identified as additional threats: Soil loss and elevated erosion rates from OHV trails and staging areas, camping, facilities construction and maintenance, habitat alteration due to invasive species and/or natural vegetation community succession, climate change and the local effect on precipitation patterns and temperature, and stochastic events. The following sections provide a summary of the past, current, and potential future threats relating to San Benito evening-primrose.

#### *Off-Highway Vehicle Use*

Off-highway vehicle use of open serpentine barrens and alluvial terraces was considered the primary threat to San Benito evening-primrose when it was listed in 1985. Soil disturbance from OHVs increased soil loss, soil compaction, and could result in the physical removal of plants. Staging areas and camping associated with OHV use had similar negative impacts to the species and its habitat. Between 1985 and 2010, the BLM implemented a series of measures to reduce effects to known habitat and occurrences of San Benito evening-primrose through fencing of sensitive areas, signage, designation of specific open riding areas, and enforcement and management of designated OHV trails. In 2005, the BLM estimated 50,000 visitor-use days per year occurred within the CCMA (USFWS 2006, p. 27).

OHV use decreased in 2008 following the release of an EPA report that found high levels of naturally occurring asbestos that posed a significant health risk to visitors within the Serpentine ACEC.

To address the EPA findings, the BLM issued new Management Plans and associated Records of Decision in 2014, which restricted OHV access by reducing the amount of open trails and restricting access to the Serpentine ACEC to 5 days per year per recreationalist through a permit system and a series of locked gates (BLM 2014, pp. 1–18). Currently, only highway-licensed vehicles are allowed within the Serpentine ACEC on designated roads and by permit, which is limited to 5 use-days per year per person. These restrictions on OHV use have effectively removed OHV impacts to San Benito evening-primrose. OHV non-compliance with fencing and trail restrictions has been monitored within lands managed by the BLM. Findings of non-compliance remain low compared to levels of use prior to closure (table 2).

Occurrences located on private property are not protected from OHV use, and occurrences on BLM land near private land are at greater risk of disturbance from OHV trespass. Under the current Resource Management Plan (BLM 2014, entire), because of its implementation of closures and restrictions, we do not consider OHV use to be a current threat or that it will become a threat to occurrences on BLM land in the foreseeable future. While BLM restrictions do not provide protection to occurrences on private land, the best available data on historical and current recreation levels do not indicate that the level of OHV use on private land will increase from current levels to levels that would threaten the persistence of the species in the foreseeable future.

#### *Mining*

The last commercial mining in the CCMA ceased extraction activities in 2002 (BLM 2018, p. 66). The BLM has acquired surface rights to 208 ha (520 ac) along the lower reaches of Clear Creek up to and including the confluence with the San Benito River. This acquisition protects habitat and occurrences of San Benito evening-primrose, but without having the mineral rights to the land, it cannot be considered fully under the control of the BLM (USFWS 2009, p. 13). The BLM decided in the 2014 Resource Management Plan that no mineral leasing or sales on public lands will occur within the Serpentine ACEC and that mineral leasing and sales on public

lands outside of the Serpentine ACEC will have “no surface occupancy” stipulations where occupied special status species habitat occurs (BLM 2014, pp. 1–36–1–37). With these requirements, and no active mining leases within suitable habitat and known occurrences, we conclude that mining is no longer a significant threat to San Benito evening-primrose and is not likely to become a threat in the foreseeable future.

Rock hounding (hobby of collecting rock and mineral specimens) within the CCMA persists as a recreation activity, although information on the amount and effect of rock hounding on San Benito evening-primrose is lacking. However, given the restricted vehicle access and relatively low impact of an individual user versus a commercial mining operation, we consider that effects to San Benito evening-primrose from rock hounding are negligible and are not likely to become a threat in the foreseeable future.

#### *Soil Loss and Elevated Erosion Rates*

Soil loss and erosion may occur naturally due to seasonal disturbances as would be expected by frost heaving, overland sheet flow from precipitation, unconsolidated soil, sparse vegetation, and flood events. Some natural disturbances benefit the species by promoting areas relatively free of dense vegetation, increasing water infiltration, and aiding in dispersal of the San Benito evening-primrose downstream or downslope from existing occurrences. Many of the threats presented under Factor A may be considered a “disturbance” to the habitat of the species, but this does not mean that they are beneficial. For example, the effects to soil from frost heaving and overland sheet flow are very different from those resulting from repeated use of OHVs. The BLM attempted to quantify the differences between the natural, or background, rates of soil loss and erosion, and those that result from OHV and highway vehicle use. The mean background soil loss in the Clear Creek Watershed was 8 yards<sup>3</sup> (yd<sup>3</sup>) per acre per year (ac-year) (11 tons/ac-year) and that soil loss resulting from OHV open riding resulted in soil loss of 12 yd<sup>3</sup>/ac-year (16 tons/ac-year) (PTI Environmental 1993, pp. 36–39). The erosion rate from roads was estimated at 59 yd<sup>3</sup>/ac-year (80 tons/ac-year).

Increased erosion and elevated soil loss are indicative of loss of suitable habitat. The seed bank may be lost as soil erodes, and the remaining soil may become compacted, decreasing germination potential as well as water retention. Trails that form from repeated

use on open slopes or terraces may collect and funnel water, creating runnels, which in turn increase erosion while drawing water away from adjacent areas (Brooks and Lair 2005, p. 7; Ouren et al. 2007, pp. 5–16). The BLM has recognized this issue and has attempted to enact minimization measures for soil loss and erosion. In the most recent Resource Management Plan, the BLM includes guidelines that call for road closures during extreme wet weather, prioritizing closed roads for restoration and reclamation, and establishing automated weather stations to monitor precipitation and soil moisture and requires approved erosion control strategies to be evaluated for any soil-disturbing activities on slopes of 20–40 percent (BLM 2014, p. 1–30). Presently, the threat of soil loss and erosion is limited to natural cycles, remnant effects of past land use, and roads (for which the above minimization measures apply). Considering that additional sub-occurrences of San Benito evening-primrose continue to be identified and remain viable within habitat that is more prone to erosion (upland slopes of the geologic transition zone habitat type), it is unlikely that natural rates of soil loss and erosion present a threat to the continued existence of the species and are not likely to do so in the foreseeable future.

#### *Facilities Construction and Maintenance*

The construction of the BLM Section 8 Administrative Site in 1988 and associated structures resulted in direct loss of San Benito evening-primrose and its habitat, although the species still occurs in the vicinity of the disturbance (USFWS 2009, pp. 12–13; BLM 2018, p. 34). The Section 8 Administrative Site was decommissioned in 2010 and replaced by the Clear Creek Administrative Site. The new administrative site was not constructed on occupied or potential habitat for San Benito evening-primrose, although the impacts resulting from the original disturbance remain (BLM 2018, p. 66). The old Section 8 Administrative Site is infrequently used and, at current levels of use, does not present a threat to the persistence of San Benito evening-primrose, as evidenced by the discovery of new sub-occurrences and potential habitat throughout the CCMA (BLM 2018, p. 66). No new facilities and construction projects are planned, and it is not likely that new projects in occupied or potential habitat will be proposed in the foreseeable future.

#### *Habitat Alteration Due to Invasive Species*

The serpentine-derived soils inhibit invasion from nonnative plant species where San Benito evening-primrose occurs. However, the habitat may still be degraded if invasion by nonnative species occurs on adjacent land. High densities of nonnative species may negatively influence existing or potential habitat for San Benito evening-primrose by providing a persistent threat of colonization. Yellow star thistle (*Centaurea solstitialis*) and tocalote (*C. melitensis*) have been actively controlled near occurrences of San Benito evening-primrose within the CCMA since 2005 (BLM 2018, p. 62). The BLM has identified prescribed fire followed by broadcast application of clopyralid, a broadleaf specific herbicide, as the most effective means of reducing the cover of invasive species threatening San Benito evening-primrose. The cover of yellow star thistle has been reduced by 95 percent in the Clear Creek drainage, and San Benito evening-primrose has expanded into the improved habitat (BLM 2018, p. 62). The natural buffer that the serpentine-derived soils provide, coupled with BLM’s management of invasive species and the expansion of known sub-occurrences and potential habitat, make it unlikely that invasive species present a significant threat either now or into the foreseeable future to the persistence of San Benito evening-primrose. The abundance of invasive species will be monitored as part of the post-delisting monitoring plan. The post-delisting monitoring plan will suggest thresholds that will determine the necessary control efforts on federally managed land.

#### *Succession to Woody Shrub Community*

San Benito evening-primrose habitat is typically open and relatively free of high amounts of woody vegetation and canopy cover. Succession to a woody shrub community in habitat that presently or historically supported San Benito evening-primrose could result in increased canopy cover (potentially shading out San Benito evening-primrose) and increased competition for resources (lessening the success of establishment and survival) (Taylor 1990, p. 66). Photopoints initiated by the BLM in 1980 indicate that open serpentine barrens are less susceptible to encroachment by woody shrubs (typically chaparral species such as manzanita (*Arctostaphylos* spp.)) than alluvial terrace habitat. This is presumably due to the greater concentration of serpentine soils on the



open barrens compared to the more organic rich soils of the alluvial terraces.

The immediate effect of encroachment by woody vegetation would be to reduce, or possibly eliminate, known occurrences and potential habitat of San Benito evening-primrose through competition and alteration of habitat structure. It is possible that the seed bank, once established, is long lived enough that it may persist through cycles of vegetation community shifts due to natural events such as fires as has been observed at least once within the CCMA (BLM 2020d, p. 3). The BLM has estimated that seed may remain viable for 107 years in the presence of common co-occurring shrubs (BLM 2015, pp. 16–28).

San Benito evening-primrose has not been observed in the geologic transition zone habitat for as long a period of time as either alluvial terrace habitat or the open serpentine barrens. The rate of succession to woody vegetation is being monitored through photopoint monitoring by the BLM (BLM 2020e, entire). It is likely that the rate of succession to woody habitat is less within geologic transition zone habitat than alluvial terrace, but greater than the rate of succession compared to open serpentine barrens. Succession of plant communities is a natural process and may result in loss of current or potential habitat. However, the amount of new sub-occurrences that have been identified lessen the immediate risk to the existence of the species; therefore, succession to woody shrub community is not currently a species-level threat. No occurrences of San Benito evening-primrose have been extirpated due to succession of woody vegetation since monitoring began in 1980, and, because San Benito evening-primrose grows on serpentine soils, threats to the species from succession to woody vegetation is also unlikely to be a threat in the foreseeable future.

#### *Stochastic Events*

At the time of listing, only nine occurrences of San Benito evening-primrose were known within a relatively restricted range. The small number of occurrences increased the susceptibility of the species to extinction from a stochastic event, such as a fire, flood, drought, or other

unpredictable event, because a single event had the capability to negatively impact all known occurrences at the same time. The vulnerability of the species to extinction from stochastic events has decreased as the number of known occurrences has increased to 79 occurrences (519 sub-occurrences or 666 point locations) occurring across multiple watersheds, and into a new habitat type (the geologic transition zone). The species' current known range is approximately 307 square miles, an area large enough that it is unlikely that a single stochastic event would be able to impact the species.

Within this broad range, approximately 260 ac (105 ha) is considered potential habitat (BLM 2018, p. 31), and 63.2 ac (25.6 ha) are known to be occupied. Despite the occupied area being relatively small, it is spread over a large geographic area across multiple habitat types and many occurrences, suggesting a low possibility of extinction from a single stochastic event. The presence of a long-lived and well-established seed bank further insulates San Benito evening-primrose from the possibility of extinction due to a single stochastic event. The land management practices of the BLM within the CCMA have promoted preserving and restoring San Benito evening-primrose habitat and the natural soil processes and hydrology of the watersheds it occurs within as well. Stochastic events are unlikely to threaten the species in the foreseeable future due to the current range of San Benito evening-primrose and number of known occurrences.

#### *Climate Change*

The terms “climate” and “climate change” are defined by the Intergovernmental Panel on Climate Change (IPCC). The term “climate change” thus refers to a change in the mean or variability of one or more measures of climate (for example, temperature or precipitation) that persists for an extended period, whether the change is due to natural variability or human activity (IPCC 2014a, pp. 119–120). The effects of climate change are wide ranging but include alteration of historical climate patterns including storm frequency and severity, seasonal shifts in temperatures, and changing

precipitation patterns. Globally, these effects may be positive, neutral, or negative for any given species, ecosystem, land use, or resource, and they may change over time (IPCC 2014b, pp. 49–54; IPCC 2018, pp. 9–12). Potential effects derived from climate change have consequences for the biological environment and may result in changes to the suitability of currently occupied habitat through increased drought stress, shortened growing seasons, and alteration of the historical soil and hydrologic cycles. The effects of these changes to San Benito evening-primrose and its habitat are not known, but we may reasonably infer potential effects from the globally anticipated changes. The State of California assessment on climate change provides a better estimate for the effects of climate change to areas occupied by San Benito evening-primrose.

California released its fourth climate change assessment in 2018 (Langridge 2018, entire). California's Fourth Climate Change Assessment uses downscaled versions of the global climate models used by IPCC to create localized predictions based on future emissions scenarios to provide relevant predictions for management and planning. The range of San Benito evening-primrose falls within the Central Coast region of California's fourth climate change assessment. In general, the region is expected to experience increasing minimum and maximum temperatures and slight increases in precipitation with significant increases in variability (Langridge 2018, p. 6). These expected trends are consistent within the range where San Benito evening-primrose occurs. The predicted increases in minimum temperature, maximum temperature, and precipitation are similar for both high (representative concentration pathway (RCP) 8.5) and low (RCP 4.5) emissions scenarios and across model variations (Cal-adapt 2020, p. NA; table 5). Data from weather stations within the range of San Benito evening-primrose indicate that the historical and/or modeled estimate of precipitation is high (by approximately 2–4 inches) and that the estimate of minimum temperature is low (by approximately 5 °F) (BLM 2020a, pp. 3, 9–10).

TABLE 5—CHANGES IN PRECIPITATION, MINIMUM AVERAGE TEMPERATURE, AND MAXIMUM AVERAGE TEMPERATURE FOR LOW AND HIGH EMISSION SCENARIOS COMPARED TO HISTORICAL AVERAGES THROUGHOUT THE RANGE OF SAN BENITO EVENING-PRIMROSE

Precipitation (inches)		Minimum average temperature (°F)		Maximum average temperature (°F)	
Historical average	RCP 4.5 (RCP 8.5)	Historical average	RCP 4.5 (RCP 8.5)	Historical average	RCP 4.5 (RCP 8.5)
20.2	23.5 (22.5)	38.4	41.3 (41.9)	70.0	72.9 (73.4)

Reported values for the modeled futures are based on the average of the HadGEM2-ES (warmer and drier), CNRM-CM5 (cooler and wetter), and CanESM2 (average) models for running climate simulations. The RCP 4.5 scenario refers to a future scenario where emissions peak near 2040 and then decline, while RCP 8.5 refers to a scenario where emissions continue to rise strongly through 2050 and plateau near 2100. The historical average is based on the years 1950–2005 as reported by cal-adapt.org. The modeled values are estimates from the years 2020–2050. A user defined boundary was used and was based on a polygon that was drawn to encompass all areas where San Benito evening-primrose occurs.

Based on the state of California assessment of climate change, the IPCC data, taking into account known uncertainties with climate change projection, the effects of the predicted changes due to climate change to occurrences of San Benito evening-primrose are varied and possibly contradictory (e.g., increased minimum temperatures may have both positive and negative effects). An increase in precipitation may provide additional water during the growing season, but the variability between seasons may result in long periods of drought followed by high-volume precipitation that may cause erosion. Increasing minimum temperatures may reduce the amount of days with frost, reducing seedling mortality but may also delay germination (BLM 2020a, pp. 6–7). Increasing maximum temperatures could result in increased stress for flowering individuals. Conversely, increased amounts of rain may promote increased germination and seedling success.

The BLM conducted a climate envelope analysis comparing the range of precipitation and temperature values that San Benito evening-primrose and two close relatives, *Camissonia contorta* and *C. strigulosa*, occupy and evaluating

the precipitation and temperature range that San Benito evening-primrose would shift into under the future climate scenarios. Under current conditions, the San Benito evening-primrose occupies a small precipitation and temperature niche that overlaps with both *C. contorta* and *C. strigulosa* suggesting that those species may indicate the environmental tolerance of San Benito evening-primrose. Under the considered future climate scenarios the precipitation and temperature range would fall within the current known habitable range of *C. contorta* and *C. strigulosa* suggesting that the predicted changes in climate would be tolerable by San Benito evening-primrose (BLM 2020a, pp. 5–7, 14–15).

Shifts in community composition are likely to occur as a result of changes in California’s climate and may impact the long-term suitability of currently occupied and potential habitat for San Benito evening-primrose. All California macrogroups of vegetation are expected to have moderate to high risk of vulnerability to climate change (Thorne et al. 2016, p. 1). This means that all vegetation communities are susceptible to portions of their current range becoming unsuitable. It is also possible that previously unsuitable areas for a

given macrogroup will become suitable as physical parameters that were previously unfavorable become favorable. Vegetation communities migrating higher in elevation along temperature gradients or moving upland as sea levels rise along hydrological gradients are typical examples of this scenario. However, the ability of a vegetation macrogroup to migrate assumes that natural seed dispersal pathways are available, and that undeveloped land exists along dispersal pathways.

San Benito evening-primrose occurs within three macrogroups within San Benito and Fresno Counties: California foothill and valley forests and woodlands, chaparral, and California annual and perennial grassland. California foothill and valley forests and woodlands and chaparral are both ranked at moderate risk of vulnerability, and California annual and perennial grassland is ranked as moderate to high risk of vulnerability (Thorne et al. 2016, p. 3; table 6). Estimates of the percent of existing habitat that will become unsuitable, have no change, or become newly suitable based on low and high emissions scenarios are shown in table 6 based on data within Thorne et al. (2016, pp. 33–41, 114–122, 132–140).

TABLE 6—RESULTS OF SENSITIVITY AND ADAPTIVE CAPACITY MODELING AND THE RESULTING CHANGE IN SUITABILITY OF EXISTING HABITAT FOR THREE VEGETATION MACROGROUPS WITHIN WHICH SAN BENITO EVENING-PRIMROSE OCCURS

Vegetation macrogroup	Mean vulnerability rank	Unsuitable		No change		Newly suitable	
		Low (%)	High (%)	Low (%)	High (%)	Low (%)	High (%)
California foothill and valley forests and woodlands.	Moderate .....	24	59	41	76	11	34
Chaparral .....	Moderate .....	8	54	46	92	17	47
California annual and perennial grassland.	Mid-High .....	16	48	52	84	10	52

Data from Thorne et al. 2016 pp. 3, 33–41, 114–122, 132–140.

Under both high and low emissions scenarios, currently suitable habitat for San Benito evening-primrose is lost due

to changes in climate. Conversely, the species that compose the vegetation communities that are associated with

San Benito evening-primrose are expected to have the capability to migrate into newly suitable habitat. The

primary concern, in regard to San Benito evening-primrose habitat, is the threat of an increase in woody vegetation as a response to climate change. However, San Benito evening-primrose is found in serpentine and serpentine-derived soils that are not likely to be affected by climate change in the foreseeable future. The edaphic (soil) conditions may restrain woody vegetation migration into areas currently occupied. While the soil type may mitigate habitat loss due to habitat conversion, it may also restrain the species from dispersing to areas where climatic conditions are more favorable for survival. The currently predicted changes in precipitation and climate do not indicate that the species may become endangered due to those changes in the foreseeable future.

#### *Existing Regulatory Mechanisms*

##### *State Protections*

San Benito evening-primrose is classified by the California Native Plant Society (CNPS) as 1B.1, indicating that the taxon is rare throughout its range and is generally endemic to California as well as having been reduced throughout its historical range. Species ranked by CNPS as 1B.1 meet the definition of threatened in the California Endangered Species Act as described in the California Fish and Game Code (CNPS 2018 Rare Plant Inventory website) and must therefore be considered during environmental analysis for California Environmental Quality Act (CEQA) documentation (CEQA 2018 Guidelines Section 15380). Environmental analysis for CEQA documentation may analyze impacts to the species and recommend protection and conservation measures.

##### *Federal Protections*

The BLM has regulations and policies that guide the management of natural resources on the public lands they manage. In particular, the Federal Land Policy and Management Act of 1976 provides for “the management, protection, development, and enhancement” of public lands managed by the BLM. This law directs the BLM to “take any action necessary to prevent unnecessary or undue degradation of the lands” during mining operations (43 U.S.C. 1732(b)). Certain mining operations, and certain other defined operations, require a plan of operations approved by the BLM (see 43 CFR part 3800, subpart 3809).

BLM may enact special rules to protect soil, vegetation, wildlife, threatened or endangered species, wilderness suitability, and other

resources by immediately closing affected areas to off-road vehicles that are causing resource damage until the adverse effects are eliminated and measures are implemented to prevent recurrence (43 FR 8340–8364; March 1, 1978).

Two Executive Orders (E.O.) apply specifically to off-road vehicles on public lands: E.O. 11644 directs agencies to designate zones of off-road use that are based on protecting natural resources, the safety of all users, and minimizing conflicts among various land uses. The BLM and other agencies are to locate such areas and trails to minimize damage to soil, watershed, vegetation, or other resources, and to minimize disruption to wildlife and their habitats. Areas may be located in designated park and refuge areas or natural areas only if the head of the agency determines that off-road use will not adversely affect the natural, aesthetic, or scenic values of the locations. The respective agencies are to ensure adequate opportunity for public participation in the designation of areas and trails.

E.O. 11989 amends the previous order by adding the following stipulations: (a) Whenever the agency determines that the use of off-road vehicles will cause or is causing considerable adverse effects on the soil, vegetation, wildlife, wildlife habitat, or cultural or historic resources of particular areas or trails on public lands, it is to immediately close the areas or trails to the type of off-road vehicle causing the effects until it determines that the adverse effects have ceased and that measures are in place to prevent future recurrence; and (b) each agency is to close portions of public lands within its jurisdiction to off-road vehicles except areas or trails designated as suitable and open to off-road vehicle use.

In 2001, the BLM published the National Management Strategy for Motorized Off-Highway Vehicle Use on Public Lands. This guiding document ensures consistent and positive management of environmentally responsible motorized OHV use on public lands. Detailed regulations are established in BLM’s 2014 Resource Management Plan for the CCMA that provide for protections of San Benito evening-primrose. BLM’s 2014 Resource Management Plan for the CCMA is in place until superseded. The restriction of OHV use within the CCMA and the Serpentine ACEC is based on concerns of health risks and will be unaffected by the delisting of San Benito evening-primrose. Currently, only highway-licensed vehicles are allowed within the Serpentine ACEC on designated roads

and by permit, which is limited to 5 use-days per year per person, and within the CCMA trail riding is restricted to designated areas near Condon Peak (BLM 2014, p. 1–18).

While San Benito evening-primrose was listed under the Act, the BLM consulted with the Service on any activities it funds, authorizes, or carries out that may affect the species. The Act does not provide protection for listed plants on non-Federal lands, unless a person damages or destroys federally listed plants while in violation of a State law or a criminal trespass law. Where the species occurs on private lands, protections afforded by section 7(a)(2) of the Act are triggered only if there is a Federal nexus (*i.e.*, an action funded, permitted, or carried out by a Federal agency). If the species is delisted, the protections afforded by the Act would no longer apply. Even in the absence of the protections of the Act, adequate regulatory mechanisms are in place, such as the Federal Land Policy and Management Act of 1976, E.O. 11644, and E.O. 11989, to ensure the continued persistence of San Benito evening-primroses occurrences and suitable potential habitat, in light of the increased number of populations and decreased threats that the species experiences now relative to at the time of listing.

##### *Summary of Threats Analysis*

A very limited range, small number of occurrences, and direct and indirect threats from OHV use and mining and associated facilities and road maintenance were the primary threats to San Benito evening-primrose at the time of listing in 1985 (50 FR 5755–5759, February 12, 1985). OHV use continued to be a significant threat to San Benito evening-primrose until the temporary closure of the Serpentine ACEC in 2008. The 2014 Resource Management Plan permanently reduced the amount of exposure San Benito evening-primrose has to OHV recreation and has resulted in indirectly removing the most significant threat to the species, which was direct loss of individuals by OHV recreation and indirect loss of habitat and seed bank through erosion on slopes and soil compaction on alluvial terraces. The threat from mining was reduced by 2002 with the closure of the last commercial mine, and future threats from mining are unlikely based on BLM management actions listed in the 2014 Resource Management Plan for the CCMA. Habitat alteration from invasive species and succession to woody vegetation communities are not likely to threaten San Benito evening-primrose because invasive species and woody

vegetation communities are intolerant to serpentine soils. The significant increase in the number of known occurrences and the associated increase in range and the new habitat association greatly reduce the threat of stochastic events resulting in significant loss to the species. The predicted changes in temperature and rainfall by 2050 as a result of climate change do not indicate species-level threats to survival.

When individual threats that influence reproductive output, germination, and survival occur together, one threat may add to, or exacerbate, the effects of another, resulting in a disproportionate increase in threat to the species. When this occurs, we call the interactive effects synergistic or cumulative. The lack of current threats to San Benito evening-primrose reduce the possibility of synergistic or cumulative effects occurring, and, given the current range of the species, number of known occurrences, and likelihood of new occurrences to become known, synergistic and cumulative effects do not pose a significant population-level impact to San Benito evening-primrose at this time nor do we anticipate that they will in the future.

#### Summary of Comments and Recommendations

In the proposed rule published in the **Federal Register** on June 1, 2020 (85 FR 33060), we requested that all interested parties submit written comments on our proposal to delist the San Benito evening primrose by July 31, 2020. We also contacted appropriate Federal and State agencies, scientific experts and organizations, and other interested parties and invited them to comment on the proposal. We did not receive any requests for a public hearing. All substantive information provided during the comment period has either been incorporated directly into this final rule or is addressed below.

During the comment period, we received comments from 10 individuals addressing the proposed rule, representing 9 public commenters and 1 partner review. Public comments are posted at <https://www.regulations.gov> under Docket No. FWS-R8-ES-2019-0065. Five public commenters supported the proposed rule with no additional analysis or revision requested. These comments are not further addressed. One public commenter supported the proposed rule but maintained a concern for vehicular threats. Two public comments were against the proposed rule but did not provide substantive information that could be evaluated or incorporated and

are not addressed further. One public commenter was against the proposed rule and provided substantive information that is addressed below. The BLM provided partner review of the proposed rule and post-delisting monitoring plan in support of the proposed rule and provided additional information. BLM comments and new information have been incorporated into the text of the final rule. Public comments are addressed below.

#### Public Comments

(1) *Comment:* One commenter acknowledged recovery of San Benito evening primrose and concurred with the conclusions of the proposed rule but maintained a concern for changes to current OHV regulations.

*Our Response:* Changes to the regulation of OHV use of the Clear Creek Management Area and the Serpentine ACEC are governed by the BLM's 2014 Record of Decision. Changes in OHV use of these areas would initiate environmental review, and potential impacts and threats to San Benito evening primrose would be evaluated during that process. This concern is addressed under the discussion of *Existing Regulatory Mechanisms*.

(2) *Comment:* One commenter disagreed with the conclusions of the proposed rule based on evidence of continued OHV trespass of occupied areas, the potential for the reopening of the CCMA and the Serpentine ACEC, occurrences on private land without protections, and the adequacy of the post-delisting monitoring plan.

*Our Response:* Continued trespass has been documented by the BLM and was addressed in the proposed rule. The level of trespass shown and described in the comment, as well as updated trespass information provided by the BLM, have been incorporated into the final rule. Based on the available population data and analysis, and supporting documentation provided by the BLM, we conclude that the current level of trespass does not place the species in danger of extinction or becoming endangered in the foreseeable future. The number of additional occurrences of the species in areas unaffected by OHV use reduces the likelihood that OHV trespass is likely to lead to the extinction of the species. However, the Service acknowledges the potential for OHV use to result in negative effects to the species, and this issue is addressed in the post-delisting monitoring plan, developed in coordination with the BLM. The post-delisting monitoring plan will evaluate disturbance (from OHV use and other sources) in the context of the biology of

the species. The post-delisting monitoring plan requires a reevaluation of the status of the species if negative trend thresholds are reached for aboveground abundance and seed bank size (see post-delisting monitoring plan).

Changes to the vehicular use of the CCMA and the Serpentine ACEC are governed by the BLM's 2014 Record of Decision. Changes in vehicular use of these areas would initiate environmental review, and potential impacts and threats to San Benito evening primrose would be evaluated during that process. This concern is addressed under the discussion of *Existing Regulatory Mechanisms*.

Many occurrences of San Benito evening primrose do occur on private land. However, the number of occurrences on public land where the conservation of the species is a management goal is large enough to warrant delisting because the species is not in danger of extinction now or in the foreseeable future.

#### Determination of San Benito Evening-Primrose Status

Section 4 of the Act (16 U.S.C. 1533) and its implementing regulations (50 CFR part 424) set forth the procedures for determining whether a species meets the definition of "endangered species" or "threatened species." The Act defines an "endangered species" as a species that is "in danger of extinction throughout all or a significant portion of its range," and a "threatened species" as a species that is "likely to become an endangered species within the foreseeable future throughout all or a significant portion of its range." For a more detailed discussion on the factors considered when determining whether a species meets the definition of "endangered species" or "threatened species" and our analysis on how we determine the foreseeable future in making these decisions, see Regulatory and Analytical Framework, above.

#### Status Throughout All of Its Range

After evaluating threats to the species and assessing the cumulative effect of the threats under the section 4(a)(1) factors, we have assessed the best scientific and commercial information available regarding the past, present, and future threats faced by San Benito evening-primrose in this final rule. At the time of listing in 1985 (50 FR 5755-5759, February 12, 1985), San Benito evening-primrose was known from only nine occurrences within a very narrow range that were all subject to potential loss from the threats listed in Factors A through E.

Off-highway vehicle recreation (Factor A), the greatest persistent threat to the species, has been reduced to levels that no longer pose a significant threat of extinction to San Benito evening-primrose or loss of its habitat, due to the closure of the Serpentine ACEC and the restriction of OHV use within the CCMA but outside of the Serpentine ACEC. Most significantly, surveys by the BLM have shown that the species is much more wide-ranging and common than originally known and occurs across a broader range of habitat types. The number of known occurrences has increased from 9 to 79 and includes 666 mapped point locations. The range of the species is now known from three watersheds, and occupied habitat covers 63.2 acres (25.6 ha).

Our understanding of the ecology of the species has demonstrated that the species weathers periods of disturbance due to the persistence of a robust and long-lived seedbank that facilitates reestablishment and dispersal and buffers against stochastic events. Annual surveys of San Benito evening-primrose have demonstrated a large amount of interannual variation in numbers of individuals observed. The 27 occurrences monitored since 1998 have remained stable around a 5-year moving average. Further, the significant increase in the number of occurrences was not contemplated at the time the Recovery Plan was written, which focused recovery on increases to the 27 occurrences. The best available information indicates that Factors A, B, C, and E are not affecting the species and are unlikely to do so in the foreseeable future. The existing regulatory mechanisms in place are adequate to ensure the continued viability of San Benito evening-primrose occurrences and suitable potential habitat even if the species is delisted and protections under the Act are removed, because a majority of occurrences are managed on Federal land and are protected by a 2014 BLM Resource Management Plan and a BLM ACEC designation.

Based on the information presented in this status review, the recovery criteria in the Recovery Plan have been achieved, and the recovery goal identified in the Recovery Plan has been met for San Benito evening-primrose. Thus, after assessing the best available information, we conclude that San Benito evening-primrose is not in danger of extinction now or likely to become so within the foreseeable future throughout all of its range.

#### *Status Throughout a Significant Portion of Its Range*

Under the Act and our implementing regulations, a species may warrant listing if it is in danger of extinction or likely to become so within the foreseeable future throughout all or a significant portion of its range.

Having determined that San Benito evening-primrose is not in danger of extinction or likely to become so within the foreseeable future throughout all of its range, we now consider whether it may be in danger of extinction or likely to become so within the foreseeable future in a significant portion of its range—that is, whether there is any portion of the species' range for which it is true that both (1) the portion is significant; and (2) the species is in danger of extinction now or likely to become so in the foreseeable future in that portion. Depending on the case, it might be more efficient for us to address the “significance” question or the “status” question first. We can choose to address either question first. Regardless of which question we address first, if we reach a negative answer with respect to the first question that we address, we do not need to evaluate the other question for that portion of the species' range.

In undertaking this analysis for San Benito evening-primrose, we choose to address the status question first—we consider information pertaining to the geographic distribution of both the species and the threats that the species faces to identify any portions of the range where the species is endangered or threatened. San Benito evening-primrose occurs over 300 square miles, but occupies a relatively small amount of acreage (63.2 ac (25.6 ha) of occupied habitat). Genetic analysis indicated no differentiation in occurrences based on watershed or habitat and that there was no hybridization with a close relative. Every threat to the species in any portion of its range is a threat to the species throughout all of its range, and so the species has the same status under the Act throughout its narrow range. Therefore, we conclude that the species is not in danger of extinction now or likely to become so in the foreseeable future in any significant portion of its range. This does not conflict with the courts' holdings in *Desert Survivors v. U.S. Department of the Interior*, 321 F. Supp. 3d 1011, 1070–74 (N.D. Cal. 2018), and *Center for Biological Diversity v. Jewell*, 248 F. Supp. 3d 946, 959 (D. Ariz. 2017) because, in reaching this conclusion, we did not need to consider whether any portions are significant and therefore did not apply the aspects of the Final Policy's

definition of “significant” that those court decisions held were invalid.

#### *Determination of Status*

Our review of the best scientific and commercial data available indicates that the San Benito evening-primrose does not meet the definition of an endangered species or a threatened species in accordance with sections 3(6) and 3(20) of the Act. Therefore, with this rule, we delist the San Benito evening-primrose from the List of Endangered and Threatened Plants.

#### **Effects of This Rule**

This final rule revises 50 CFR 17.12(h) by removing San Benito evening-primrose from the Federal List of Endangered and Threatened Plants. On the effective date of this rule (see **DATES**, above), the prohibitions and conservation measures provided by the Act, particularly through sections 7 and 9, will no longer apply to San Benito evening-primrose. Federal agencies will no longer be required to consult with the Service under section 7 of the Act in the event that activities they authorize, fund, or carry out may affect San Benito evening-primrose. There is no critical habitat designated for this species, so there will be no effect to 50 CFR 17.96.

#### **Post-Delisting Monitoring**

Section 4(g)(1) of the Act requires us to implement a monitoring program for not less than 5 years for all species that have been delisted due to recovery. Post-delisting monitoring (PDM) refers to activities undertaken to verify that a species delisted due to recovery remains secure from the risk of extinction after the protections of the Act no longer apply. The primary goal of PDM is to monitor the species to ensure that its status does not deteriorate, and if a decline is detected, to take measures to halt the decline so that proposing it as endangered or threatened is not again needed. If, at any time during the monitoring period, data indicate that protective status under the Act should be reinstated, we can initiate listing procedures, including, if appropriate, emergency listing under section 4(b)(7) of the Act. Section 4(g) of the Act explicitly requires us to cooperate with the States in development and implementation of post-delisting monitoring programs, but we remain responsible for compliance with section 4(g) and, therefore, must remain actively engaged in all phases of post-delisting monitoring. We also seek active participation of other entities that are expected to assume responsibilities for the species' conservation post-delisting.

*Post-Delisting Monitoring Overview*

A post-delisting monitoring plan was developed in partnership with the BLM. The post-delisting monitoring has been designed to verify that San Benito evening-primrose remains secure from risk of extinction after its removal from the Federal List of Endangered and Threatened Plants by detecting changes in population trends of known occurrences. The Act has a minimum post-delisting monitoring requirement of 5 years; however, if populations decline in abundance past the defined threshold in the post-delisting monitoring plan, or a substantial new threat arises, post-delisting monitoring may be extended or modified and the status of the species will be reevaluated.

Post-delisting monitoring will occur for 5 years with the first year of monitoring beginning the first spring following the publication of the final delisting rule. Post-delisting monitoring will annually census aboveground individuals within the 27 occurrences listed in the Recovery Plan, which are also the 27 occurrences that have been used to evaluate population trends in the final rule. Annual monitoring of disturbance frequency and intensity will also occur annually in conjunction with the annual census. Seed bank quantification will occur in years 2 and 5 to determine if there has been a loss of viable seed across the range of habitat types. Woody vegetation structure will be evaluated in year 5 and compared to data collected in 2020, the year the proposed rule was published, to evaluate potential changes in habitat suitability across habitat types and historical disturbance levels. A final post-delisting monitoring plan for the species can be found at <https://www.regulations.gov> under Docket No. FWS-R8-ES-2019-0065. We will work closely with our partners to maintain the recovered status of the San Benito evening-primrose and ensure post-delisting monitoring is conducted and future management strategies are implemented (as necessary) to benefit the San Benito evening-primrose.

**Required Determinations***National Environmental Policy Act (42 U.S.C. 4321 et seq.)*

We have determined that environmental assessments and environmental impact statements, as defined under the authority of the National Environmental Policy Act (42 U.S.C. 4321 et seq.), need not be prepared in connection with determining a species' listing status under the Endangered Species Act. We published a notice outlining our reasons

for this determination in the **Federal Register** on October 25, 1983 (48 FR 49244). This position was upheld by the U.S. Court of Appeals for the Ninth Circuit (*Douglas County v. Babbitt*, 48 F.3d 1495 (9th Cir. 1995), cert. denied 516 U.S. 1042 (1996)).

*Government-to-Government Relationship With Tribes*

In accordance with the President's memorandum of April 29, 1994 (Government-to-Government Relations with Native American Tribal Governments; 59 FR 22951), Executive Order 13175 (Consultation and Coordination with Indian Tribal Governments), and the Department of the Interior's manual at 512 DM 2, we readily acknowledge our responsibility to communicate meaningfully with recognized Federal Tribes on a government-to-government basis. In accordance with Secretarial Order 3206 of June 5, 1997 (American Indian Tribal Rights, Federal-Tribal Trust Responsibilities, and the Endangered Species Act), we readily acknowledge our responsibilities to work directly with Tribes in developing programs for healthy ecosystems, to acknowledge that Tribal lands are not subject to the same controls as Federal public lands, to remain sensitive to Indian culture, and to make information available to Tribes. There are no Tribal lands associated with this final rule, and we did not receive any comments on the proposed rule from Tribes.

**References Cited**

A complete list of all references cited in this final rule is available on the internet at <https://www.regulations.gov> under Docket No. FWS-R8-ES-2019-0065, or upon request from the Ventura Fish and Wildlife Office (see **FOR FURTHER INFORMATION CONTACT**).

**Authors**

The primary authors of this final rule are the staff members of the Ventura Fish and Wildlife Office in Ventura, California, in coordination with the Pacific Southwest Regional Office in Sacramento, California.

**List of Subjects in 50 CFR Part 17**

Endangered and threatened species, Exports, Imports, Plants, Reporting and recordkeeping requirements, Transportation, Wildlife.

**Regulation Promulgation**

Accordingly, we hereby amend part 17, subchapter B of chapter I, title 50 of the Code of Federal Regulations, as set forth below:

**PART 17—ENDANGERED AND THREATENED WILDLIFE AND PLANTS**

■ 1. The authority citation for part 17 continues to read as follows:

**Authority:** 16 U.S.C. 1361–1407; 1531–1544; and 4201–4245, unless otherwise noted.

**§ 17.12 [Amended]**

■ 2. Amend § 17.12, in paragraph (h), by removing the entry for “*Camissonia benitensis*” under Flowering Plants from the List of Endangered and Threatened Plants.

**Martha Williams,**

*Principal Deputy Director, Exercising the Delegated Authority of the Director, U.S. Fish and Wildlife Service.*

[FR Doc. 2022–02010 Filed 2–2–22; 8:45 am]

**BILLING CODE 4333–15–P**

**DEPARTMENT OF THE INTERIOR****Fish and Wildlife Service****50 CFR Part 17**

[Docket No. FWS-R8-ES-2019-0025; FF09E22000 FXES1113090FEDR 223]

RIN 1018–BD45

**Endangered and Threatened Wildlife and Plants; Reclassification of Morro Shoulderband Snail From Endangered to Threatened With Section 4(d) Rule**

**AGENCY:** Fish and Wildlife Service, Interior.

**ACTION:** Final rule.

**SUMMARY:** We, the U.S. Fish and Wildlife Service (Service), are reclassifying the Morro shoulderband snail (*Helminthoglypta walkeriana*) from endangered to threatened under the Endangered Species Act of 1973, as amended (Act). This action is based on our evaluation of the best available scientific and commercial information, which indicates that the species' status has improved such that it is not currently in danger of extinction throughout all or a significant portion of its range, but that it is still likely to become so in the foreseeable future. We also finalize a rule issued under section 4(d) of the Act that provides for the conservation of the Morro shoulderband snail. In addition, we update the Federal List of Endangered and Threatened Wildlife to reflect the latest scientifically accepted taxonomy and nomenclature for the species as *Helminthoglypta walkeriana*, Morro shoulderband snail.

**DATES:** This rule is effective March 7, 2022.

**ADDRESSES:** This final rule is available on the internet at <https://www.regulations.gov>. Comments and materials we received, as well as supporting documentation we used in preparing this rule, are available for public inspection at <https://www.regulations.gov> under Docket No. FWS-R8-ES-2019-0025.

**FOR FURTHER INFORMATION CONTACT:**

Stephen P. Henry, Field Supervisor, U.S. Fish and Wildlife Service, Ventura Fish and Wildlife Office, 2493 Portola Road, Suite B, Ventura, CA 93003; telephone 805-644-1766. Persons who use a telecommunications device for the deaf (TDD) may call the Federal Relay Service at 800-877-8339.

**SUPPLEMENTARY INFORMATION:**

**Previous Federal Actions**

On December 15, 1994, we published a final rule (59 FR 64613) listing *Helminthoglypta walkeriana* (Morro shoulderband snail (=banded dune snail)) as endangered. This taxon contained two entities: *H. walkeriana* (what we now consider the Morro shoulderband snail) and *H. walkeriana morroensis* (what we now consider the Chorro shoulderband snail). At the time of listing in 1994, we thought the subspecific entity *morroensis* was extinct and that there may have been as few as several hundred individuals of *Helminthoglypta walkeriana* remaining (59 FR 64613, p. 64615, December 15, 1994); consequently, we did not consider the *morroensis* subspecies to be part of the listed entity.

In 1997, the subspecific entity *morroensis* was rediscovered at North Point Natural Area near the northern limit of Morro Bay (Roth and Tupen 2004, p. 3). In subsequent years, it was found in other areas as well. In 1998, we completed the Recovery Plan for the Morro Shoulderband Snail and Four Plants from Western San Luis Obispo County (Service 1998, entire), and in 2001, we designated critical habitat for the Morro shoulderband snail (66 FR 9233; February 7, 2001). Both the recovery plan and critical habitat addressed only *Helminthoglypta walkeriana* and not the subspecific entity *morroensis*, as explained above.

In 2004, a taxonomic analysis was completed that elevated these subspecific taxa to full species: *Helminthoglypta walkeriana* and *H.*

*morroensis* (Roth and Tupen 2004, entire). After 2004, *H. walkeriana* and *H. morroensis* were associated with the common names Morro shoulderband snail and Chorro shoulderband snail, respectively. Also in 2004, in an attempt to provide clarity on what was the listed entity, the Ventura Fish and Wildlife Office issued a “Dear Stakeholders and Interested Parties” letter stating we would no longer be regulating the Chorro shoulderband snail (Service 2004, entire).

However, in 2006, the Service completed a 5-year review for both the Morro and Chorro shoulderband snails and recommended downlisting Morro shoulderband snail from endangered to threatened and delisting Chorro shoulderband snail (Service 2006, entire), even though the Chorro shoulderband snail had previously not been treated as part of the listed entity.

Neither entity, *Helminthoglypta walkeriana morroensis* or the newly recognized *Helminthoglypta morroensis*, was ever formally added to the Federal List of Endangered and Threatened Wildlife. Because of its confusing history, however, we determined that it was most appropriate to now complete a listing assessment to determine whether or not the Chorro shoulderband snail meets the definition of an “endangered species” or of a “threatened species” in the Act (16 U.S.C. 1531 *et seq.*). Using the results of our evaluation in the species status assessment (SSA) report, we reaffirm our 5-year review that the information on the threats to the Chorro shoulderband snail does not support the species being listed as endangered or threatened under the Act. Since *Helminthoglypta morroensis* is not currently included on the Federal List of Endangered and Threatened Wildlife, no revision to the list is needed to implement this determination.

On July 24, 2020, we published a proposed rule (85 FR 44821) to reclassify the Morro shoulderband snail (*Helminthoglypta walkeriana*) from an endangered to a threatened species under the Act. In that proposed rule, we also announced the availability of a species assessment form constituting our full determination and threats analysis regarding the status of the Chorro shoulderband snail (Service 2020, entire), which is available on the internet at <https://www.regulations.gov>

under Docket No. FWS-R8-ES-2019-0025.

**Summary of Changes From the Proposed Rule**

This final rule incorporates two minor substantive changes to our July 24, 2020, proposed rule (85 FR 44821). First, we made a slight edit to the preamble text of the rule issued under section 4(d) rule of the Act (“4(d) rule”) to remove reference to a specific fire protection plan. We made this change to clarify that any fire protection plan meeting the standards set out in the 4(d) rule will be exempted from take prohibitions. Additionally, based on a public comment, we clarified the effect of conservation on the downlisting of the Morro shoulderband snail. We made no other substantive changes from the July 24, 2020, proposed rule in this final rule.

**Supporting Documents**

A species status assessment (SSA) team prepared an SSA report for the Morro shoulderband snail and the Chorro shoulderband snail (Service 2019). The SSA team was composed of Service biologists, in consultation with other species experts. The SSA report represents a compilation of the best scientific and commercial data available concerning the status of the species, including the impacts of past, present, and future factors (both negative and beneficial) affecting the species. In accordance with our joint policy on peer review published in the **Federal Register** on July 1, 1994 (59 FR 34270), and our August 22, 2016, memorandum updating and clarifying the role of peer review of listing actions under the Act, in 2018, we sent the SSA report to peer reviewers with expertise in snail ecology, microhabitat, and distribution, which included three experts from partner agencies: The California Department of Fish and Wildlife (CDFW), the California Department of Parks and Recreation (hereafter, State Parks), and the County of San Luis Obispo. We received six responses, including from two reviewers from partner agencies: Biologists at State Parks and the County of San Luis Obispo. We incorporated the results of those reviews, as appropriate, into the final SSA report, which is the foundation for this final rule.

## I. Reclassification Determination

### Background

It is our intent to discuss only those topics directly related to the reclassification of Morro shoulderband snail from an endangered species to a threatened species in this final rule. Below, we summarize the conclusions of the SSA report, including the species description, ecology, habitat, and resource needs. We also discuss recovery plan implementation. In our SSA report, we define viability as the ability of the species to sustain populations in the wild over time and provide a thorough account of the species' overall condition currently and into the future. The full SSA report is available on the internet at <https://www.regulations.gov> under Docket No. FWS-R8-ES-2019-0025.

### Species Description

The Morro shoulderband snail belongs to the land snail genus, *Helminthoglypta* (Ancey 1887), which contains three subgenera comprising more than 100 species and subspecies. Morro shoulderband snail shells are umbilicate (having a depression at the center), globose (spherical), reddish brown to chestnut in color, thin, and slightly translucent (Roth 1985, p. 5). The shell has five to six whorls and a single, narrow (2 to 2.5 millimeters (mm) (0.08 to 0.1 inches (in.))), dark spiral band on the "shoulder" with thin light-yellowish margins above and below. Sculptural features of the shell include incised spiral grooves, spiral and transverse striae (grooves) that give the surface a checkerboard-like look, and papillae (small, round protrusions) at the intersections of some of the striae (Walgren 2003, p. 93). Adult shell dimensions range from 18 to 29 mm (0.7 to 1.1 in.) in diameter and from 14 to 25 mm (0.6 to 1.0 in.) in height (Roth 1985, p. 5).

### Species Ecology, Habitat, and Resource Needs

In general, we know very little about the specific life history of Morro shoulderband snails. Using information compiled for other *Helminthoglypta* species (van der Laan 1975a, entire; 1975b, entire; 1980, entire), we infer information and apply it to the species, where appropriate. Like many species of *Helminthoglypta* that occur in

Mediterranean climate regions of California, the Morro shoulderband snail has adapted to changing environmental conditions by having a two-part life cycle. While feeding, reproduction, and most individual growth occur during the rainy season (Roth 1985, p. 13), individuals spend the majority of the year in aestivation (prolonged dormancy) to survive the drier seasons (Belt 2018, pers. comm.). Refugia used for the aestivation phase of the life cycle for the Morro shoulderband snail appear to be opportunistic in nature. They can include native and nonnative plant species, including dense clumps of native and nonnative grasses; young patches of ice plant (*Carpobrotus* spp.); cactus (*Opuntia* spp.); and anthropogenic features and debris (e.g., stockpiled construction materials, wood, cement, plastic) (Roth and Tupen 2004, p. 17; SWCA 2013–2017, entire; Dugan 2018, pers. comm.).

For *Helminthoglypta* species living in California, most activity occurs during the rainy season (Roth 1985, p. 13), and this is the case for Morro shoulderband snail. In coastal San Luis Obispo County, the period of greatest activity generally extends from October through April but can vary each year depending on the frequency and duration of seasonal rainfall and heavy fog/dew. During this period, individuals may be particularly active during the evening, night, and early morning hours when humidity is higher. Individuals can also be active during overcast and rainy days (van der Laan 1980, pp. 49, 52; U.S. Department of Agriculture (USDA) 1999, p. 3; Tupen 2018, pers. comm.). The Morro shoulderband snail likely emerges from aestivation during and following periods of rainfall in search of food resources and for mating and egg-laying activities.

Species of *Helminthoglypta*, like other terrestrial snails, become inactive during prolonged dry periods and enter a state of aestivation where individuals produce an epiphragm (a seal of dried mucus) across the shell aperture to greatly reduce water and weight loss (van der Laan 1975b, p. 361). They frequently aestivate attached to the lower outer branches of shrubs (van der Laan 1975b, p. 365; Roth 1985, p. 13). This attachment to a substrate may provide additional protection from desiccation by forming a more complete

seal of the aperture (van der Laan 1975b, p. 365). There is a possible decreased vulnerability to predation during dormancy when the attachment point is 20–30 centimeters (7.9–11.8 in.) above the ground surface (van der Laan 1975b, p. 365). Smaller snails tended to experience higher mortality rates during aestivation, possibly due to their thinner shells and higher surface-to-volume ratios (van der Laan 1975b, p. 364). Individuals come out of aestivation after rain events that thoroughly wet the environment and may regain as much as 50 percent of their body weight back within 24 hours (van der Laan 1975b, p. 364).

Like other terrestrial snails, we expect the Morro shoulderband snail to have a patchy distribution coincident with the presence of suitable refugia and food sources.

### Species Distribution and Abundance

Initially, Hill (1974, p. 6) and others projected a very limited distribution for *Helminthoglypta walkeriana* (as the coastal form of the banded dune snail). Its range was thought to extend only a short distance inland along the southeastern shore of Morro Bay to Shark Inlet, southward to near Islay Creek, and northward on the Morro Bay sand spit at the western edge of the community of Los Osos. In the listing rule (59 FR 64613; December 15, 1994), the Service expanded the range to include the coastal dune and coastal sage scrub communities underlain by sandy soils near Morro Bay (i.e., Los Osos). Based on known species occurrences and soil associations, we used the presence of Baywood Fine Sand soils and small areas of Dune Land soils to determine distribution. We currently estimate the distribution for the Morro shoulderband snail to be approximately 2,638 hectares (ha) (6,520 acres (ac)) located in and around the community of Los Osos/Baywood Park and City of Morro Bay (see figure, below). At the time of listing, we estimated that there may have been as few as several hundred individuals of *H. walkeriana* (currently, Morro shoulderband snail) extant. Based on the most recent surveys, thousands of Morro shoulderband snails currently exist in this area (SWCA Environmental Consultants (SWCA) 2018, p. 7).

BILLING CODE 4333-15-P



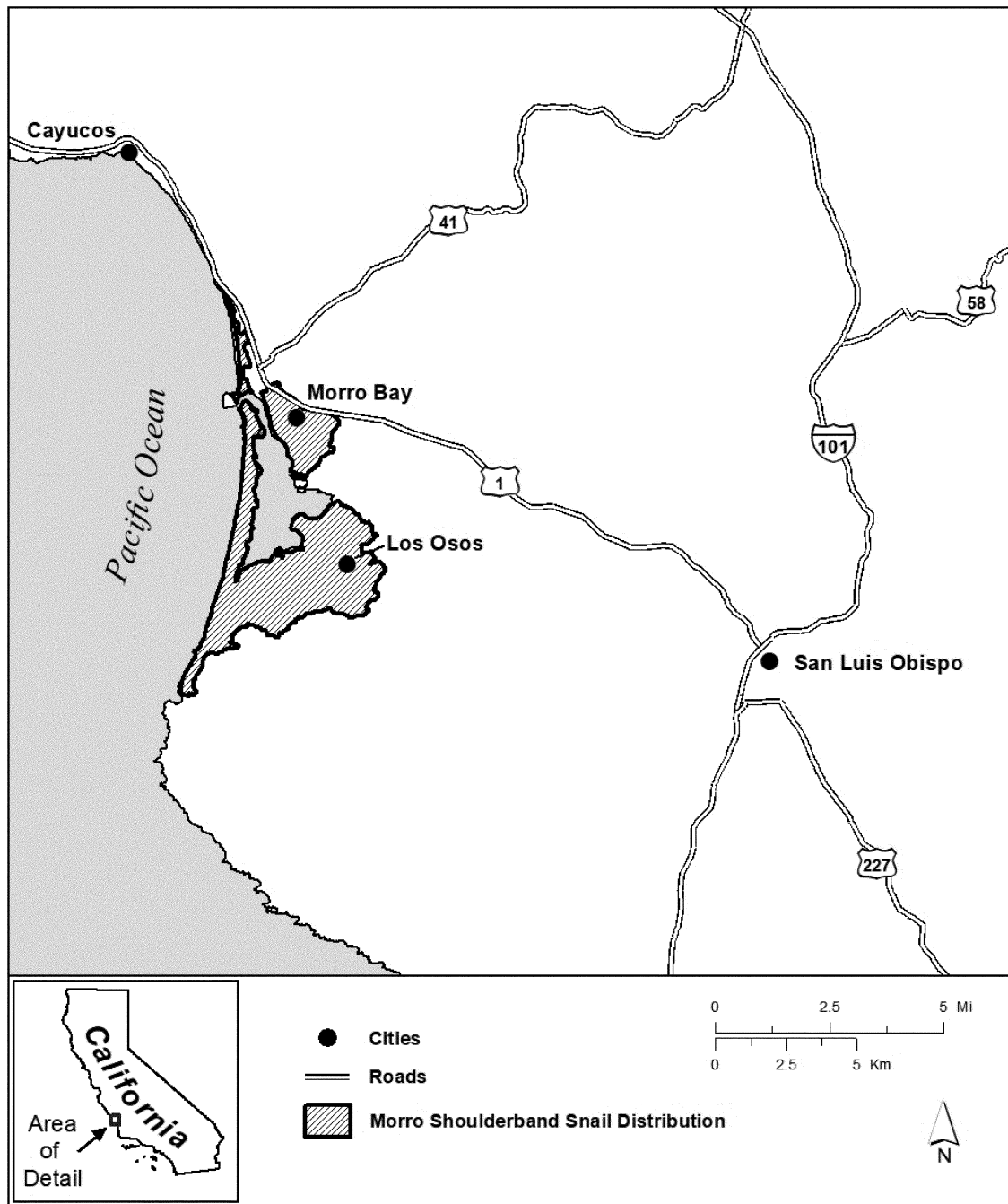

**Figure:** Distribution of the Morro Shoulderband Snail (*Helminthoglypta walkeriana*).

**BILLING CODE 4333-15-C**

Using known species occurrence and estimated abundance along with the presence of suitable soil types, we identified six geographic units (hereafter, “population areas”) for the purpose of discussion in our SSA report. These include North Morro Bay, Sand Spit, Morro Bay, East Los Osos, Downtown Los Osos, and South Los Osos. For a map and detailed description of these population areas, please reference the SSA report (Service 2019, pp. 24–29). The level of survey

effort throughout each of the six population areas comprising the distribution of the Morro shoulderband snail is limited and variable. For this reason, we are not able to make comparable estimates for species abundance. The Downtown and South Los Osos population areas have been subject to a greater level of survey effort associated with required monitoring for the installation of infrastructure to connect the community of Los Osos with its wastewater system. Between 2012 and 2017, more than 2,200

individuals were found in these two population areas, with over 80 percent occurring in the Downtown Los Osos area (SWCA 2018, p. 5).

Portions of the North Morro Bay, Sand Spit, Morro Bay, East Los Osos, and South Los Osos population areas are within State Parks ownership, but comprehensive surveys or monitoring have not been conducted. From discussions with State Parks biologists, we know Morro shoulderband snails are present on State Park lands in Montaña de Oro and Morro Bay State Parks and

Morro Strand State Beach, portions of which are found within several of the population areas. Data on the level of species occupation and condition of individuals is generally lacking (Walgren and Andreano 2018, pers. comm.). There have been no comprehensive surveys for the Morro shoulderband snail conducted on CDFW's Morro Dunes Ecological Reserve (MDER); however, based on species observations and presence of suitable habitat, CDFW assumes the reserve contains a robust population of the species (Stafford 2018, pers. comm.). While we know the species is present on MDER (Service files; Stafford 2018, pers. comm.), there is no evidence that the population is robust or that large numbers of individuals are present. Survey data gathered between 2012 and 2017 in contiguous habitat of similar quality and species composition indicate greater Morro shoulderband snail numbers in disturbed habitats than in native habitats (SWCA 2018, p. 5).

#### Recovery Criteria

Section 4(f) of the Act directs us to develop and implement recovery plans for the conservation and survival of endangered and threatened species unless we determine that such a plan will not promote the conservation of the species. Under section 4(f)(1)(B)(ii), recovery plans must, to the maximum extent practicable, include objective, measurable criteria which, when met, would result in a determination, in accordance with the provisions of section 4 of the Act, that the species be removed from the List of Endangered and Threatened Wildlife or the List of Endangered and Threatened Plants.

Recovery plans provide a roadmap for us and our partners on methods of enhancing conservation and minimizing threats to listed species, as well as measurable criteria against which to evaluate progress towards recovery and assess the species' likely future condition. However, they are not regulatory documents and do not substitute for the determinations and promulgation of regulations required under section 4(a)(1) of the Act. A decision to revise the status of a species or to delist a species is ultimately based on an analysis of the best scientific and commercial data available to determine whether a species is no longer an endangered species or a threatened species, regardless of whether that information differs from the recovery plan.

There are many paths to accomplishing recovery of a species, and recovery may be achieved without all of the criteria in a recovery plan

being fully met. For example, one or more criteria may be exceeded while other criteria may not yet be accomplished. In that instance, we may determine that the threats are minimized sufficiently and that the species is robust enough that it no longer meets the Act's definition of an endangered species or a threatened species. In other cases, we may discover new recovery opportunities after having finalized the recovery plan. Parties seeking to conserve the species may use these opportunities instead of methods identified in the recovery plan. Likewise, we may learn new information about the species after we finalize the recovery plan. The new information may change the extent to which existing criteria are appropriate for identifying recovery of the species. The recovery of a species is a dynamic process requiring adaptive management that may, or may not, follow all of the guidance provided in a recovery plan.

Below, we summarize recovery plan goals for the Morro shoulderband snail and discuss progress made toward meeting recovery plan objectives in terms of how they inform our analyses of the species' status and the stressors affecting them.

In 1998, we completed the Recovery Plan for the Morro Shoulderband Snail and Four Plants from Western San Luis Obispo County, California, which included recovery goals and objectives for Morro shoulderband snail (Recovery Plan; Service 1998, pp. 40–41). The Recovery Plan identified criteria for downlisting Morro shoulderband snail from an endangered to a threatened species and criteria for its delisting. The Recovery Plan identified four "conservation planning areas" (CPAs). These CPAs were designed to incorporate areas where distribution of the Morro shoulderband snail and three other plant species covered in the plan overlap; thus, they are more limited than the population areas for the Morro shoulderband snail defined in the SSA.

Our summary analysis of downlisting and delisting criteria follows:

The Recovery Plan stated that downlisting from endangered to threatened can be considered when sufficient populations and suitable occupied habitats from all CPAs are secured and protected (Service 1998, p. 39). These areas should be intact and relatively unfragmented by urban development. Snail populations must be large enough to minimize the short-term (next 50 years) risk of extinction on any of the four CPAs identified in the Recovery Plan, based on results of tasks 3.2.1.1, 3.2.1.2, and 3.2.1.3 (see below) and on at least preliminary results from

task 4.1. The identification and survey of potential habitat within the snail's historic range to see if undiscovered populations exist are necessary to consider downlisting.

All of CPA 1 (Morro Spit) and portions of CPAs 2, 3, and 4 (West Pecho, South Los Osos, and Northeast Los Osos) are largely secure under various ownerships and management (Service 2019, pp. 72–74). All have conservation easements or deed restrictions, or are managed by a conservation association for conservation purposes. Landowners and managers include the County, State Parks, CDFW, the Land Conservancy of San Luis Obispo County, Morro Coast Audubon Society, and the Small Wilderness Area Program (SWAP). Approximately 202 ha (500 ac) have been added to conserved lands since time of listing. This includes 56 ha (138 ac) of parcels purchased and transferred to State Parks or CDFW managed for conservation purposes and 141 ha (348 ac) with a conservation easement or deed restriction managed for conservation purposes. Overall, 85 percent (approximately 1,457 ha (3,600 ac)) of CPAs are now conserved. However, a lack of funding precludes adequate threats management on most of these lands (Service 2019, p. 53).

Recovery Task 3.2.1.1 is to determine if brown garden snail (*Cornu aspersum* (formerly *Helix aspersa*)) is a competitive threat to the Morro shoulderband snail. Since the time of listing, we found that Morro shoulderband snails feed primarily on dead plant materials and the brown garden snail consumes live plant materials, so competition between these species is likely minimal (Service 2019, p. 75).

Task 3.2.1.2 involves the study of habitat use and life-history needs of the Morro shoulderband snail. Monitoring and habitat restoration activities conducted in association with the construction of a sewer system in the community of Los Osos have generated substantial new information on the diversity of habitats in which the species can occur and numbers of individuals present. We also have new information based upon anecdotal observations and surveys conducted in association with proposed development in the Los Osos area (Service 2019, pp. 28–30).

Task 3.2.1.3 is to identify Morro shoulderband snail parasites and determine if parasitism rates are threatening populations. At the time of listing, parasitism was identified as a threat to the species, based on observations of vacant sarcophagid fly

puparia within empty subadult shells (59 FR 64613, p. 64619, December 15, 1994). Since the time of listing, there has been an increase in snail observations, but not a corresponding increase in sarcophagid fly pupae infestations of snails. A few species in this fly family have been documented to eat live material (Walgren 2003, pp. 108–114; Service 2006, p. 7). While there have been no specific studies on the potential threats to the snail from these sarcophagid flies, the majority of flies in this family do not eat live organisms; thus, we conclude that the flies do not pose a threat to the species (Service 2006, p. 13). Therefore, the best available current evidence does not indicate that parasitism is a threat to the species.

Finally, Task 4.1 is to monitor populations to document population dynamics and cycles to ascertain trends. No systematic monitoring has been conducted to provide data that would allow for trend analysis. However, based on the most recent surveys, thousands of Morro shoulderband snails were detected across the species' range, as compared to hundreds known at the time of listing (Service 2019, pp. 28–30; SWCA 2018, p. 5; Walgren and Andreano 2018, pers. comm.). Therefore, although we do not have specific trend data, we conclude that we have still met the intent of this criterion.

Delisting can be considered when habitats from all CPAs (and any newly located populations) are successfully managed to maintain the desired community structure and are secured from threats of development, invasion of nonnative plants, structural changes due to senescence of dune vegetation, recreational use, pesticides (including slug and snail baits), parasites, and competition or predation from nonnative snail species. The outcomes of recovery tasks must result in a low medium-to-long-term risk of extinction from any of the four CPAs (Service 1998, p. 40).

Our analyses in the SSA report indicate that the current viability of Morro shoulderband snail has improved to some degree since the time of listing due to information indicating there are substantially more individuals than previously thought, as well as beneficial effects of certain conservation efforts, predominantly in the form of land acquisition. Based on our future scenario analyses, the species is still at risk in the future due to the potential for development and because the level of continued conservation efforts and habitat management is uncertain. Currently and into the future, habitat loss due to development and habitat

degradation, predominantly from invasive plant species, remain threats to the Morro shoulderband snail.

To improve habitat for the species, the Morro Coast Audubon Society has a dedicated volunteer work force to remove the invasive, nonnative plant species *Ehrharta calycina* (perennial veldt grass) and *Eucalyptus globulus* (blue gum) seedlings at their Sweet Springs Preserve (outside of any CPA) under the direction of a recovery action plan. The Los Osos/Morro Bay Chapter of SWAP does the same for the Elfin Forest Reserve in CPA 4. State Parks staff annually prioritize areas for invasive species treatment on a case-by-case basis. When funding is available, they implement actions to control invasive species in Montaña de Oro State Park, Morro Strand State Beach, Morro Bay State Park, and Los Osos Oaks Preserve (CPAs 1 and 2, portions of 3 and 4, and Area A). Identified invasive species prioritized for removal include *E. calycina*, *Conicosia pugioniformis* (narrowleaf iceplant), *Emex spinosa* (devil's thorn), *Cortaderia* species, and *Eucalyptus* species because they are the most invasive and conspicuous in the landscape.

Lack of funding precludes most State of California resource agencies (e.g., State Parks and CDFW) from implementing invasive species control programs on lands where these species are present. State Parks staff have conducted limited prescribed burns and proposed additional prescribed burns to improve the quality of coastal dune scrub and central maritime chaparral and their constituent species within their park units. Fires typically kill snails, but if properly applied in small areas to create a mosaic of varying stand ages for coastal dune scrub and central maritime chaparral, such burns could improve the quality of these habitats for the Morro shoulderband snail in the long term. Previous threats to habitat resulting from illegal off-road vehicle activities are largely controlled; however, illegal trail development and use by hikers, mountain bikers, and equestrians negatively affects habitat for Morro shoulderband snails by increasing erosion, reducing native plant cover, and facilitating further invasion by nonnative plant species (Service 2019, pp. 75–76).

Based on the Recovery Plan and our SSA report, we conclude that the status of the Morro shoulderband snail has improved throughout its range due to information demonstrating that there are substantially more individuals than previously thought, and due to conservation efforts predominantly in the form of land acquisition. The SSA

report contains an accounting of known conservation and management efforts (Service 2019, pp. 23–24). Overall, our analysis indicates that the intent of the downlisting criteria for the Morro shoulderband snail has been met; however, delisting criteria have not yet been achieved.

## Regulatory and Analytical Framework

### Regulatory Framework

Section 4 of the Act (16 U.S.C. 1533) and its implementing regulations (50 CFR part 424) set forth the procedures for determining whether a species is an endangered species or a threatened species. The Act defines an “endangered species” as a species that is in danger of extinction throughout all or a significant portion of its range, and a “threatened species” as a species that is likely to become an endangered species within the foreseeable future throughout all or a significant portion of its range. The Act requires that we determine whether any species is an “endangered species” or a “threatened species” because of any of the following factors:

- (A) The present or threatened destruction, modification, or curtailment of its habitat or range;
- (B) Overutilization for commercial, recreational, scientific, or educational purposes;
- (C) Disease or predation;
- (D) The inadequacy of existing regulatory mechanisms; or
- (E) Other natural or manmade factors affecting its continued existence.

These factors represent broad categories of natural or human-caused actions or conditions that could have an effect on a species' continued existence. In evaluating these actions and conditions, we look for those that may have a negative effect on individuals of the species, as well as other actions or conditions that may ameliorate any negative effects or may have positive effects. We consider these same five factors in downlisting a species from endangered to threatened (see 50 CFR 424.11(c), (d), and (e)).

We use the term “threat” to refer in general to actions or conditions that are known to or are reasonably likely to negatively affect individuals of a species. The term “threat” includes actions or conditions that have a direct impact on individuals (direct impacts), as well as those that affect individuals through alteration of their habitat or required resources (stressors). The term “threat” may encompass—either together or separately—the source of the action or condition or the action or condition itself.

However, the mere identification of any threat(s) does not necessarily mean that the species meets the statutory definition of an “endangered species” or a “threatened species.” In determining whether a species meets either definition, we must evaluate all identified threats by considering the species’ expected response and the effects of the threats—in light of those actions and conditions that will ameliorate the threats—on an individual, population, and species level. We evaluate each threat and its expected effects on the species, then analyze the cumulative effect of all of the threats on the species as a whole. We also consider the cumulative effect of the threats in light of those actions and conditions that will have positive effects on the species—such as any existing regulatory mechanisms or conservation efforts. The Secretary determines whether the species meets the definition of an “endangered species” or a “threatened species” only after conducting this cumulative analysis and describing the expected effect on the species now and in the foreseeable future.

The Act does not define the term “foreseeable future,” which appears in the statutory definition of “threatened species.” Our implementing regulations at 50 CFR 424.11(d) set forth a framework for evaluating the foreseeable future on a case-by-case basis. The term foreseeable future extends only so far into the future as we can reasonably determine that both the future threats and the species’ responses to those threats are likely. In other words, the foreseeable future is the period of time in which we can make reliable predictions. “Reliable” does not mean “certain”; it means sufficient to provide a reasonable degree of confidence in the prediction. Thus, a prediction is reliable if it is reasonable to depend on it when making decisions.

It is not always possible or necessary to define foreseeable future as a particular number of years. Analysis of the foreseeable future uses the best scientific and commercial data available and should consider the timeframes applicable to the relevant threats and to the species’ likely responses to those threats in view of its life-history characteristics. Data that are typically relevant to assessing the species’ biological response include species-specific factors such as lifespan, reproductive rates or productivity, certain behaviors, and other demographic factors.

#### *Analytical Framework*

The SSA report documents the results of our comprehensive biological review of the best scientific and commercial data regarding the status of the species, including an assessment of the potential threats to the species. The SSA report does not represent our decision on whether the species should be reclassified as a threatened species under the Act. It does, however, provide the scientific basis that informs our regulatory decisions, which involve the further application of standards within the Act and its implementing regulations and policies. The following is a summary of the key results and conclusions from the SSA report; the full SSA report can be found on the internet at <https://www.regulations.gov> under Docket No. FWS-R8-ES-2019-0025.

To assess Morro shoulderband snail viability, we used the three conservation biology principles of resiliency, redundancy, and representation (Shaffer and Stein 2000, pp. 306–310). Briefly, resiliency supports the ability of the species to withstand environmental and demographic stochasticity (for example, wet or dry, warm or cold years), redundancy supports the ability of the species to withstand catastrophic events (for example, droughts, large pollution events), and representation supports the ability of the species to adapt over time to long-term changes in the environment (for example, climate changes). In general, the more resilient and redundant a species is and the more representation it has, the more likely it is to sustain populations over time, even under changing environmental conditions. Using these principles, we identified the species’ ecological requirements for survival and reproduction at the individual, population, and species levels, and described the beneficial and risk factors influencing the species’ viability.

The SSA process can be categorized into three sequential stages. During the first stage, we evaluated individual species’ life-history needs. The next stage involved an assessment of the historical and current condition of the species’ demographics and habitat characteristics, including an explanation of how the species arrived at its current condition. The final stage of the SSA involved making predictions about the species’ responses to positive and negative environmental and anthropogenic influences. Throughout all of these stages, we used the best available information to characterize viability as the ability of a species to sustain populations in the wild over

time. We use this information to inform our regulatory decision.

#### **Summary of Biological Status and Threats**

Below, we review the biological condition of the species and its resources, and the threats that influence the species’ current and future condition, in order to assess the species’ overall viability and the risks to that viability.

We note that, by using the SSA framework to guide our analysis of the scientific information documented in the SSA report, we have not only analyzed individual effects on the species, but we have also analyzed their potential cumulative effects. We incorporate the cumulative effects into our SSA analysis when we characterize the current and future condition of the species. To assess the current and future condition of the species, we undertake an iterative analysis that encompasses and incorporates the threats individually and then accumulates and evaluates the effects of all the factors that may be influencing the species, including threats and conservation efforts. Because the SSA framework considers not just the presence of the factors, but to what degree they collectively influence risk to the entire species, our assessment integrates the cumulative effects of the factors and replaces a standalone cumulative effects analysis.

We reviewed the potential threats that could be affecting Morro shoulderband snails now and in the future. In this final rule, we discuss in detail only those factors that could meaningfully affect the status of the species. At the time of listing, we identified urban development and other anthropogenic activities such as recreation, grazing, and utility construction as threats to the Morro shoulderband snail (59 FR 64613; December 15, 1994). In the SSA report (Service 2019, pp. 21–64), we reviewed four potential threats that could be affecting the current condition of the Morro shoulderband snail (development, agriculture, vegetation management, and predation), and those threats and two others (wildfire, invasive species) that could affect the future condition of the species. For the Morro shoulderband snail, we consider the foreseeable future to be 30 years. This timeframe takes into account threats associated with fire, habitat degradation, and climate change, and also the implementation of the Los Osos Habitat Conservation Plan (LOHCP).

The primary risk factors affecting the Morro shoulderband snail are the present and threatened modification or

destruction of its habitat from development, wildfire, and invasive plant species (Factor A), as well as effects to its life cycle from changing climate conditions (Factor E). We also considered the effect of existing regulatory mechanisms (Factor D) on the magnitude of threats. Additional threats affecting the species' habitat include agriculture (Factor A) and vegetation management (Factor A), and threats affecting the species include predation (Factor C); however, we have determined that these threats have little to no impact on the species' viability. We also analyzed the threat of collection (Factor B). At the time of listing, we stated that the taxonomic distinctiveness of the Morro shoulderband snail made it vulnerable to recreational or scientific collectors. Since the time of listing, however, we are not aware of specific collection activities for recreational or scientific purposes. Therefore, we conclude that overcollection (Factor B) is not a threat to the species.

#### *Development*

At the time of listing, development was identified as one of the main threats impacting the Morro shoulderband snail. Human development consists of converting the landscape into residential, commercial, industrial, and recreational features, with associated infrastructure such as roads. Converting the landscape into development not only removes individual Morro shoulderband snails but also removes their habitat, thereby reducing the space available for the species to inhabit and functionally lowering carrying capacity. In addition, development results in indirect effects by fragmenting the habitat and creating edge effects, such as increased vulnerability to desiccation, fire, and predation. The effects of development on the Morro shoulderband snail are predicated upon several factors (e.g., how the City and County of San Luis Obispo revise and implement their respective general plans, the economy, water availability).

However, as detailed in the SSA report, conservation actions have been undertaken since the time of listing to reduce the threat of development (Service 2019, pp. 24–25). Approximately 202 ha (500 ac) of Morro shoulderband snail habitat have been conserved since the time of listing. This includes 56 ha (138 ac) of parcels purchased and transferred to the California Department of Parks and Recreation (CDPR) or CDFW and 141 ha (348 ac) with conservation easement or deed restriction; all of these areas are managed for conservation purposes.

Overall, 85 percent (approximately 1,457 ha (3,600 ac)) of CPAs are now protected from development. Although most lands within the species' distribution outside of CPAs are not under formal or legal protection as open space or conservation easements, many are protected as part of a State Park, State of California ecological reserve, or parcels set aside specifically to conserve and enhance natural resource values. For example, the County of San Luis Obispo's Broderson and Midtown parcels are both protected through deed restrictions that preclude development other than that which would enhance habitat that supports Morro shoulderband snails. With increased conserved lands, the threat of development has been reduced since the time of listing, but some potential impacts remain that could result in the loss of populations and thus the loss of representation and redundancy across the species' range. For example, large portions of the East Los Osos and Downtown Los Osos population areas consist predominantly of public and private land parcels zoned for development. Apart from the protections afforded by the Act, the existing regulatory mechanisms do not address the impacts of development on the Morro shoulderband snail.

#### *Invasive Species*

Invasion of native habitat by nonnative plant species can reduce suitability for native constituent species that evolved in these habitats. Areas dominated by a single invasive plant species tend to support lower levels of animal diversity due to a reduction in heterogeneity as compared to the original native plant community (Steidl and Litt 2009, p. 57). The presence of nonnative plant species can also alter the abundance of native plants that serve as an important food source for herbivores, such as snails. Invasive plant species can increase vegetative cover and reduce space between native plant species in native communities. Invasive plant species can change fuel properties in native habitats, which can then affect fire behavior and alter fire regime characteristics such as frequency, severity, extent, type, and seasonality (Brooks et al. 2004, entire). In coastal dune scrub and maritime chaparral, native communities that typically support a sparse understory, invasive grasses, such as perennial veldt grass, can serve as ladder fuel to carry fire into these communities. Fires can also create an opportunity for invasive plant species to expand their local distributions and dominance (Brooks and Lusk 2008, p. 9).

While once thought to be largely restricted to native coastal scrub communities underlain by sandy soils, Morro shoulderband snails are known to occur, at least in the short term, in disturbed areas and those dominated by nonnative species (e.g., perennial veldt grass, ice plant) (SWCA 2018, p. 5). Biologists and land planners typically classify these areas as ruderal or "disturbed" and, as such, discount them in terms of their conservation value. Ruderal, disturbed, and nonnative grassland habitats are, therefore, subject to mowing, herbicide use, development, and other uses that put individual Morro shoulderband snails in these areas at a greater risk of injury or mortality than those found in native habitat.

Currently, three of the six population areas that support the Morro shoulderband snail are in moderate- or low-quality habitat, with impacts from nonnative species (Service 2019, pp. 37–38). Habitat in these areas is either somewhat degraded (one population area) (9.5 percent of species distribution) or highly degraded and fragmented (two population areas) (38.3 percent of species distribution).

Both the Morro Coast Audubon Society and SWAP conduct activities to improve habitat quality for the Morro shoulderband snail and other coastal dune scrub species on lands conserved and protected under their ownership and/or management (Sweet Springs Nature Preserve and Elfin Forest, respectively). These actions focus primarily on the removal of exotic plant species (perennial veldt grass, iceplant), restoration of coastal dune scrub, and erosion control. The CDPR also conducts similar activities on its lands (i.e., Montaña de Oro and Morro Bay State Parks and Morro Strand State Beach). The County of San Luis Obispo owns two large parcels in Los Osos, Broderson and Mid-Town, that support coastal dune scrub and, to a lesser extent, central maritime chaparral. Management actions on both parcels focus on the restoration and enhancement of habitat for the Morro shoulderband snail (Kevin Merk Associates, LLC (KMA) 2017, entire; County of San Luis Obispo 2017, entire). The Land Conservancy of San Luis Obispo County recently purchased approximately 5.7 ha (14 ac) adjacent to the Morro Coast Audubon Society's Sweet Springs Preserve. They plan to enhance habitat quality for coastal dune scrub species, including Morro shoulderband snail, before transferring these lands to Morro Coast Audubon Society ownership and management (Theobald 2017, pers. comm.). Overall,

while these conservation measures have decreased the overall impact of invasive plant species, degradation of native habitats from those species is ongoing, and the existing regulatory mechanisms do not address the impact of invasive species.

#### *Wildfire*

Morro shoulderband snails evolved in a fire-adapted landscape dominated by coastal dune scrub and maritime chaparral. Exposure to fire can result in individual mortality; however, an evolutionary strategy has enabled the species to persist in these habitats. Theories related to the nature of fire history in California shrublands are complicated and varied (Goforth and Minnich 2007, p. 779). In the range of the Morro shoulderband snail, the “natural” condition was one of frequent, small fires that fragmented the landscape into a fine-grained mosaic of age classes that precluded large, catastrophic fires (Minnich and Chou 1997, p. 244). In this type of situation, areas of unburned coastal dune scrub and central maritime chaparral would serve as refugia for individual snails that could then recolonize areas as the fire-adapted plant communities reestablished.

We consider an increase in wildfire frequency and/or intensity associated with continued climate change to be plausible in the future within the range of the Morro shoulderband snail (Service 2019, entire). A landscape-level or more severe fire event would constitute a threat to the species due to its very limited distribution. This type of fire could leave little in the way of habitat to serve as native refugia and result in a substantial amount of individual mortality, increasing the likelihood of local population extirpation. Absent individuals in nearby habitat to recolonize burned areas as habitat reestablishes, large-scale fire could result in a reduction in the overall distribution of the species, and thus loss of redundancy and representation. The existing regulatory mechanisms do not address the impact of wildfire on the Morro shoulderband snail or its habitat.

#### *Climate Change*

Climate change is likely to affect many terrestrial gastropod populations in California, including the Morro shoulderband snail. Species with small geographic ranges are particularly vulnerable to extinction due to the effects of climate change (Allan et al. 2005, p. 284). In the range of the Morro shoulderband snail, climate change may result in both droughts and localized

flood events from heavy rainfall. In the future, extreme storm events may increase in severity beyond historic levels of intensity with potential to increase flood risks in California (Dettinger 2011, pp. 521–522). Future estimates of changes in temperature and precipitation patterns in California by the 2060s based on downscaled climate models show that the historically maximum July temperatures are likely to increase and heat waves may span longer durations (Pierce et al. 2013, entire).

The increased frequency of protracted drought events predicted in California is likely to result in higher mortality during prolonged periods of seasonal aestivation, particularly among smaller individuals in the population (van der Laan 1975b, p. 364). Higher levels of egg mortality from desiccation are expected. Warmer temperatures and greatly reduced wet season precipitation during prolonged multiyear drought events also increase stress on vegetation (Coates et al. 2015, p. 14277) and may limit time for feeding and breeding in the Morro shoulderband snail. Coastal sage scrub communities had the highest seasonal variability in terms of the relative amount of ground covered by green vegetation during the drought years of 2013–2014 (Coates et al. 2015, p. 14283). Coastal sage scrub plant species also had the highest land surface temperature values of the communities analyzed, likely resulting from lower vegetation cover, lower evapotranspiration, and south-facing slopes typical of coastal sage scrub communities (Coates et al. 2015, p. 14284). These effects of prolonged drought reduce the value and quality of sheltering habitat as well as food availability within the primary plant community associated with the Morro shoulderband snail. Combined with impacts from wildfire, invasive species, and development, the negative effects of climate change on growth and reproduction are likely to result in decreased population abundance and increased vulnerability to local extirpation into the future.

#### *Summary of Threats*

We examined the effects of threats affecting the Morro shoulderband snail and its habitat; we now summarize these threats and their cumulative effects on the species. Currently, the species and its habitat are being impacted by development, invasive nonnative plants, wildfire, and effects associated with climate change. Along with a decrease in habitat quality due to increased temperatures and increased frequency of droughts, the effects of

climate change may also exacerbate low population size and fragmented habitats, resulting in increased risk of extirpation. The effects of climate change will also combine with the effects of development, wildfire, and invasive species to exacerbate habitat loss and mortality of individuals. However, the magnitude of threats has decreased since the time of listing, and conservation actions have addressed some of the impacts from development and nonnative plants. Still, the species' low abundance and fragmented habitat mean it is vulnerable to threats into the future, including potential extirpation of population areas by wildfire.

#### *Current and Potential Future Condition*

We assessed the viability of the Morro shoulderband snail by evaluating its ability to maintain a sufficient number and distribution of healthy populations in order to maintain resiliency, redundancy, and representation. We analyzed threats to the species and ongoing conservation actions by incorporating the effects of development, invasive species, wildfire, and changing climate conditions into our analyses of resiliency, representation, and redundancy.

For the Morro shoulderband snail to maintain viability, its populations, or some portion thereof, need to be resilient to stochastic events. Resiliency is measured by the size and growth rate of each population, which influence the likelihood that the populations comprising a species are able to withstand or bounce back from environmental or demographic stochastic events. We evaluated variables influencing the ability of the Morro shoulderband snail to withstand stochastic events by population area, including abundance (as available), distribution of individuals, habitat quality and configuration, and the likelihood that suitable habitat would persist into the future. To determine habitat quality and configuration in each population area, we evaluated its context in the overall landscape relative to fragmentation and whether one or more of those primary constituent elements identified for critical habitat designated in 2001 (66 FR 9233; February 7, 2001) are present. Primary constituent elements for this species include the following physical or biological features: Sand or sandy soil needed for reproduction; a slope not greater than 10 percent to facilitate movement of individuals; and native coastal dune scrub vegetation. To determine the likelihood that suitable habitat will persist into the future, we evaluated the proportion of protected

habitat in each population area. We then created an overall current condition for each population area based on these three variables.

Based on overall current condition, we then forecasted the condition of these variables into the future for 30 years under three different scenarios. The three future scenarios attempt to encompass the range of plausible possibilities for each population area over the next 30 years. To forecast climate change impacts, we relied on scientific papers (Dettinger 2011, entire; Pierce et al. 2013, entire) that incorporated multi-model ensembles and downscaled regional climate projections that examine key characteristics relating to the Morro

shoulderband snail, such as summer temperatures and seasonal changes in precipitation.

First, we forecasted the condition of each population area under the status quo, with continued climate change effects, all existing threats continuing at their current level, and no additional conservation efforts for the species (“Status Quo” scenario). Second, we forecasted the condition of each population area under implementation of the LOHCP, a draft regional habitat conservation plan that proposes the Morro shoulderband snail as a covered species, against a backdrop of continued climate change effects (“Limited Conservation” scenario). In the “Limited Conservation” scenario, the

LOHCP consolidates the threat of development to one population area, while other existing threats continue at their current level. Finally, we forecasted implementation of the LOHCP, active management for the Morro shoulderband snail within existing protected but generally unmanaged lands, and additional habitat protection through acquisition and subsequent management (“Major Conservation” scenario), again against a backdrop of continued climate change. The “Major Conservation” scenario includes decreased threats due to development and invasive plant species, as well as conservation benefits from habitat restoration.

TABLE—SUMMARY OF MORRO SHOULDERBAND SNAIL RESILIENCY: CURRENT AND FUTURE CONDITIONS BY POPULATION AREA

Population area	Current condition	Future scenario: Status quo	Future scenario: Limited Conservation	Future scenario: Major Conservation
North Morro Bay .....	Moderate .....	Moderate .....	Moderate .....	High.
Sand Spit .....	High .....	Moderate .....	Moderate .....	High.
Morro Bay .....	Low .....	Low .....	Low .....	Low.
East Los Osos .....	Moderate .....	Low .....	Low .....	Moderate.
Downtown Los Osos .....	Moderate .....	Low .....	Low .....	Low.
South Los Osos .....	High .....	Moderate .....	High .....	High.

Maintaining representation of healthy populations across the diversity of habitat types or ecological gradients within the distribution of Morro shoulderband snail will likely conserve the relevant genetic diversity and adaptive capacity associated with individual persistence across these habitat types. Currently, the species is represented in all of six population areas; however, changes under future scenarios could put individuals in some population areas at greater risk of extirpation, resulting in a potential loss of representation and leaving the species extant only in the periphery of its range.

The Morro shoulderband snail needs multiple resilient population areas distributed throughout its extremely limited distribution to provide for redundancy. Historically, based on the mapping of Baywood Fine Sand soils, it is likely that habitat was once well-distributed throughout the species’ range. Development now primarily separates these population areas. Low resiliency and disconnected population areas, currently and in the future, suggest that stochastic events could increase species vulnerability to loss of redundancy and could increase the risk of loss of population areas, which would then diminish species redundancy. An overall decrease in the

condition of population areas in two of the three future scenarios suggests a potential compromised redundancy and, therefore, risk of extirpation from catastrophic events in the future, unless major conservation actions are undertaken. Prolonged and/or more intensive drought, increased wildfire frequency and/or intensity, and localized flooding are those events that could affect the Morro shoulderband snail at the catastrophic scale.

The resiliency of Morro shoulderband snail population areas within the species’ distribution has changed over time due to loss, degradation, and/or fragmentation of native habitat. Currently, we consider two population areas (Sand Spit and South Los Osos) to have a high level of resiliency, three population areas (North Morro Bay, East Los Osos, Downtown Los Osos) to have moderate resiliency, and one population area (Morro Bay) to have a low resiliency. It is not likely that loss of the Morro Bay population area would affect species representation across the remaining portion of the range, as current numbers of individuals in this population area are very low, and it is generally isolated from the other five population areas. Regarding population redundancy, we consider those population areas with low or moderate resiliencies to be at a greater risk of local

extirpation, which has the potential to decrease overall species redundancy.

Our analyses indicate that the current viability of the Morro shoulderband snail has likely improved to some degree since the time of listing because there are substantially more individuals than thought at the time of listing and certain conservation efforts (predominantly protection of habitat through conservation easement, deed restriction, or management for conservation purposes) have been implemented.

Overall, we anticipate that the viability of the species will decline in the future under two of the three scenarios: “Status Quo” and “Limited Conservation.” Under the “Status Quo” scenario, resiliency of the North Morro Bay and Morro Bay population areas would remain moderate and low, respectively, while all other population areas would be expected to experience decreased resiliency. Under the “Status Quo” scenario, half of the population areas are projected to be in the low resiliency category. Under the “Limited Conservation” scenario, resilience of the North Morro Bay, Morro Bay, and South Los Osos population areas would remain unchanged. The South Los Osos population area is where the majority of the conservation strategy for the LOHCP would occur. Only in the “Major

Conservation” scenario does resiliency remain the same or improve, with the exception of Downtown Los Osos, where we anticipate the majority of development would occur as part of LOHCP implementation. For redundancy, an overall decrease in the condition of population areas in two of the three future scenarios suggests those low-condition populations are at risk of being lost and, therefore, that there could be decreased species redundancy. Against a backdrop of increased climate change effects expected to result in prolonged and/or more intensive droughts, increased wildfire frequency and/or intensity, and localized flooding events, risk of extirpation could increase with decreased species redundancy.

### Summary of Comments and Recommendations

In the proposed rule published on July 24, 2020 (85 FR 44821), we requested that all interested parties submit written comments on the proposed reclassification of the Morro shoulderband snail from endangered to threatened and the associated proposed 4(d) rule by September 22, 2020. We also contacted appropriate Federal and State agencies, scientific experts and organizations, and other interested parties and invited them to comment on the proposal. Newspaper notices inviting general public comment were published in the San Luis Obispo Tribune. We did not receive any requests for a public hearing. We received seven public comments. Six expressed only opinions in support or in opposition to the proposed downlisting without supporting information.

#### Peer Reviewer Comments

As discussed in Supporting Documents above, we received comments from six peer reviewers during the 2018 peer review of the SSA. We reviewed all comments we received from the peer reviewers for substantive issues and new information regarding the information contained in the SSA report. The peer reviewers generally concurred with our methods and conclusions, and provided additional information, clarifications, and suggestions to improve the final SSA report, including on snail morphology, habitat preferences, and behavior. Peer reviewer comments were incorporated into the final SSA report (Service 2019, entire).

#### Comments From Federal Agencies, States, and Tribes

We did not receive any comments from Federal agencies, States or State

agencies, or Tribes during the public comment period.

#### Public Comments

(4) *Comment:* One commenter thought that the proposed rule inferred that the Service did not intend to include the Chorro shoulderband snail in the original 1994 listing. The commenter notes that, in fact, information in the Service’s Ventura Fish and Wildlife Office’s files indicates that the inclusion of the Chorro shoulderband snail in the 1994 listing rule was intentional. The commenter stated that the proposed rule states that it was appropriate to complete a listing assessment for the Chorro shoulderband snail.

*Our response:* We acknowledge that the Chorro shoulderband snail was part of the taxonomic entity that was included in the original listing rule in 1994 (59 FR 64613; December 15, 1994). We further acknowledge the confusing history of the two taxa, and that we referred to them in different ways in the original listing rule (59 FR 64613; December 15, 1994), the designated critical habitat (66 FR 9233; February 7, 2001), and our 2004 letter to partners. We address the inconsistency under Summary of Previous Federal Actions, above. Additionally, in the July 24, 2020, proposed rule (85 FR 44821), we announced the availability of a Species Assessment form constituting our full determination and threats analysis regarding the status of the Chorro shoulderband snail (Service 2020, entire). In that assessment, we determined that, based on the best available science, the Chorro shoulderband snail does not meet the Act’s definition of an “endangered species” or a “threatened species.” Although information on the Chorro shoulderband snail is limited, under section 4(b)(1)(A) of the Act, we are required to make our determinations based solely on the best scientific and commercial data available at the time of our rulemaking.

(5) *Comment:* One commenter noted the line in the proposed rule that states, “the current viability of Morro shoulderband snail has improved to some degree since the time of listing due to concerted conservation efforts” and thought that this means the proposed rule infers that conservation measures are the reason for the substantial increase in numbers. The commenter notes the reason for increase in knowledge of number of snails is based on surveys from ruderal/disturbed habitat, not from the acreage that has been conserved. Commenter notes most of the land that has been conserved is not managed for the Morro

shoulderband snail. Currently, the Morro shoulderband snail is not restricted to native habitat and is able to persist in highly disturbed areas and those dominated by nonnative plant species.

*Our response:* We have revised the rule to clarify that we are reclassifying the Morro shoulderband snail from endangered to threatened (*i.e.*, “downlisting” the species) because there are substantially more individuals than previously thought, as well as beneficial effects of certain conservation efforts, predominantly in the form of land acquisition, since the time the species was listed. We acknowledge that those lands are not managed for the Morro shoulderband snail; however, they still provide protection from development, which was one of the greatest threats identified at the time of listing.

#### Determination of Morro Shoulderband Snail’s Status

Section 4 of the Act (16 U.S.C. 1533) and its implementing regulations (50 CFR part 424) set forth the procedures for determining whether a species meets the definition of an “endangered species” or a “threatened species.” The Act defines an “endangered species” as a species that is in danger of extinction throughout all or a significant portion of its range, and a “threatened species” as a species that is likely to become an endangered species within the foreseeable future throughout all or a significant portion of its range. For a more detailed discussion on the factors considered when determining whether a species meets the definition of an “endangered species” or a “threatened species” and our analysis on how we determine the foreseeable future in making these decisions, please see Regulatory and Analytical Framework, above.

#### Status Throughout All of Its Range

We evaluated threats to the species and assessed the cumulative effect of the threats under the Act’s section 4(a)(1) factors. This included an examination of the best scientific and commercial information available regarding the past, present, and future threats faced by the species, as well as information presented in the 2006 5-year review (Service 2006, entire), additional information available since the 5-year review was completed, and other available published and unpublished information. We also consulted with species experts and land management staff who are actively managing habitat for the conservation of the Morro shoulderband snail.



The primary risk factors affecting Morro shoulderband snails are the present and threatened modification or destruction of its habitat from development (Factor A), wildfire (Factor A), and invasive species (Factor A), as well as effects to its life cycle from changing climate conditions (Factor E). We also considered the threat of collection (Factor B), agriculture and vegetation management (Factor A) and predation (Factor C) (Service 2019, pp. 21–45). Finally, we examined the adequacy of existing regulatory mechanisms in addressing these threats (Factor D).

Threats influencing the viability of Morro shoulderband snail populations at the time of listing were urban development, off-road vehicle activity, nonnative vegetation (referred to as invasive species in this final rule), parasitoids (an insect whose larvae live as parasites that eventually kill their hosts), and competition from brown garden snails, all of which were exacerbated by effects associated with small population size and drought conditions (59 FR 64613; December 15, 1994). Since the time of listing, we have determined that some of these threats are no longer affecting the species, particularly off-road vehicle activity, brown garden snails, parasitoids, and controlled burns (Service 2006, pp. 11–15). Our current analysis indicates that the remaining threats identified at the time of listing have been reduced in magnitude, and that overall the level of impacts to Morro shoulderband snail and its habitat that placed the species in danger of extinction in 1994 have been substantially reduced. These reductions have occurred predominantly because of significant protection of lands at risk of development and surveys indicating that population numbers now occur in the thousands rather than the hundreds. However, threats are still impacting the species and its habitat, and new threats have been identified since the time of listing.

Of the factors identified above, habitat loss and degradation from fragmentation associated with development and invasive plant species (Factor A), wildfire (Factor A), and effects to the Morro shoulderband snail's life cycle from changing climate conditions (Factor E) are the most significant threats to the species currently and into the foreseeable future. Conservation actions have somewhat decreased the magnitude of impacts from nonnative, invasive plant species; however, degradation of native habitats by these species is ongoing. Apart from the protections afforded by the Act, no regulatory mechanisms are addressing

the threats impacting the species and its habitat.

We considered plausible future conditions for the Morro shoulderband snail to evaluate the status of the species into the future. Under the “Status Quo” scenario, the species would lose resiliency due to continued threats of habitat loss, decreasing habitat quality due to invasive species and drought, and increased wildfire frequency and intensity. These effects will increase into the future, putting some population areas at risk of extirpation. Major conservation efforts, including implementation of the LOHCP conservation program, active management within currently protected but generally unmanaged lands throughout the distribution of the species, and additional habitat protection through acquisition and subsequent management, could help ameliorate some of these threats in the future; however, this level of conservation is not sufficiently certain to be implemented.

After our review and analysis of threats as they relate to the five statutory factors, we find that this information does not indicate that these threats are affecting individual populations of Morro shoulderband snail or the species as a whole across its range to the extent that the threats currently are of sufficient imminence, scope, or magnitude to rise to the level that the species is presently in danger of extinction throughout all of its range. However, while numbers of individuals across the majority of the species' range are greater now than at the time of listing and some habitat for the species is protected from development, the species remains negatively affected by continued and future threats and inadequate resource needs across much of its range.

The best available information indicates there are continued population- and rangewide-level impacts to Morro shoulderband snails despite beneficial conservation efforts in several of the population areas that have reduced the magnitude of development. Specifically, Morro shoulderband snail populations across the range continue to be negatively affected by effects of development and invasive, nonnative plant species, although at a lower level than at the time of listing. However, in the foreseeable future, available information also indicates increasing temperatures and reductions in the amount of annual rainfall associated with climate change will likely result in prolonged drought conditions that negatively influence Morro shoulderband snail abundance in the

future, along with increasing frequency and intensity of wildfires. These effects will combine with the ongoing low-grade impacts of development and invasive plants such that the species is likely to become endangered in the foreseeable future.

After evaluating threats to the species and assessing the cumulative effect of the threats under the Act's section 4(a)(1) factors, based on the best available information, we determine that the Morro shoulderband snail is not currently in danger of extinction, but is likely to become in danger of extinction within the foreseeable future, throughout all of its range.

#### *Status Throughout a Significant Portion of Its Range*

Under the Act and our implementing regulations, a species may warrant listing if it is in danger of extinction or likely to become so in the foreseeable future throughout all or a significant portion of its range. The court in *Center for Biological Diversity v. Everson*, 2020 WL 437289 (D.D.C. Jan. 28, 2020) (*Center for Biological Diversity*), vacated the aspect of the Final Policy on Interpretation of the Phrase “Significant Portion of Its Range” in the Endangered Species Act's Definitions of “Endangered Species” and “Threatened Species” (79 FR 37578; July 1, 2014) that provided that the Service does not undertake an analysis of significant portions of a species' range if the species warrants listing as threatened throughout all of its range. Therefore, we proceed to evaluating whether the species is endangered in a significant portion of its range—that is, whether there is any portion of the species' range for which both (1) the portion is significant; and (2) the species is in danger of extinction in that portion. Depending on the case, it might be more efficient for us to address the “significance” question or the “status” question first. We can choose to address either question first. Regardless of which question we address first, if we reach a negative answer with respect to the first question that we address, we do not need to evaluate the other question for that portion of the species' range.

Following the court's holding in *Center for Biological Diversity*, we now consider whether there are any significant portions of the species' range where the species is in danger of extinction now (*i.e.*, endangered). In undertaking this analysis for the Morro shoulderband snail, we choose to address the status question first—we consider information pertaining to the geographic distribution of both the species and the threats that the species

faces to identify any portions of the range where the species is endangered.

For the Morro shoulderband snail, we considered whether the threats are geographically concentrated in any portion of the species' range at a biologically meaningful scale. We examined the following threats: Development; invasive species; wildfire; climate change; collection; agriculture and vegetation management; and predation; as well as cumulative effects. Threats do occur at different magnitudes across the range of the Morro shoulderband snail. For example, the East Los Osos and Downtown Los Osos population areas are at higher risk of development than other areas. Other population areas are at higher risk of fire, such as South Los Osos and Sand Spit. However, we found no concentration of threats in any portion of the Morro shoulderband snail's range at a biologically meaningful scale, so there is no population area where the species might be endangered. Therefore, no portion of the species' range provides a basis for determining that the species is in danger of extinction in a significant portion of its range, and we determine that the species is likely to become in danger of extinction within the foreseeable future throughout all of its range. This does not conflict with the courts' holdings in *Desert Survivors v. U.S. Department of the Interior*, 321 F. Supp. 3d 1011, 1070–74 (N.D. Cal. 2018), and *Center for Biological Diversity v. Jewell*, 248 F. Supp. 3d 946, 959 (D. Ariz. 2017) because, in reaching this conclusion, we did not need to consider whether any portions are significant and therefore did not apply the aspects of the Final Policy's definition of "significant" that those court decisions held were invalid.

#### *Determination of Status*

Our review of the best scientific and commercial data available indicates that the Morro shoulderband snail meets the Act's definition of a "threatened species." Therefore, we are reclassifying the Morro shoulderband snail as a threatened species in accordance with sections 3(20) and 4(a)(1) of the Act.

It is our policy, as published in the **Federal Register** on July 1, 1994 (59 FR 34272), to identify to the maximum extent practicable at the time a species is classified, those activities that would or would not constitute a violation of section 9 of the Act. The intent of this policy is to increase public awareness of the effect of a listing on proposed and ongoing activities within the range of the species being listed. Because we are reclassifying this species as a threatened species, the prohibitions in the section

9 of the Act will not automatically apply. We are, therefore, issuing a rule under section 4(d) of the Act (a "4(d) rule") to provide for the conservation of the species; section 4(d) authorizes us to apply any of the prohibitions in section 9 to a threatened species. The 4(d) rule, which includes a description of the kinds of activities that will or will not constitute a violation, complies with this policy.

## **II. Rule Issued Under Section 4(d) of the Act**

### **Background**

Section 4(d) of the Act contains two sentences. The first sentence states that the Secretary shall issue such regulations as she deems necessary and advisable to provide for the conservation of species listed as threatened. The U.S. Supreme Court has noted that statutory language like "necessary and advisable" demonstrates a large degree of deference to the agency (see *Webster v. Doe*, 486 U.S. 592 (1988)). Conservation is defined in the Act to mean the use of all methods and procedures which are necessary to bring any endangered species or threatened species to the point at which the measures provided pursuant to the Act are no longer necessary. Additionally, the second sentence of section 4(d) of the Act states that the Secretary may by regulation prohibit with respect to any threatened species any act prohibited under section 9(a)(1), in the case of fish or wildlife, or section 9(a)(2), in the case of plants. Thus, the combination of the two sentences of section 4(d) provides the Secretary with wide latitude of discretion to select and promulgate appropriate regulations tailored to the specific conservation needs of the threatened species. The second sentence grants particularly broad discretion to us when adopting the prohibitions under section 9.

The courts have recognized the extent of the Secretary's discretion under this standard to develop rules that are appropriate for the conservation of a species. For example, courts have upheld rules developed under section 4(d) as a valid exercise of agency authority where they prohibited take of threatened wildlife, or include a limited taking prohibition (see *Alsea Valley Alliance v. Lautenbacher*, 2007 U.S. Dist. Lexis 60203 (D. Or. 2007); *Washington Environmental Council v. National Marine Fisheries Service*, 2002 U.S. Dist. Lexis 5432 (W.D. Wash. 2002)). Courts have also upheld 4(d) rules that do not address all of the threats a species faces (see *State of Louisiana v. Verity*, 853 F.2d 322 (5th

Cir. 1988)). As noted in the legislative history when the Act was initially enacted, "once an animal is on the threatened list, the Secretary has an almost infinite number of options available to him [or her] with regard to the permitted activities for those species. He [or she] may, for example, permit taking, but not importation of such species, or he [or she] may choose to forbid both taking and importation but allow the transportation of such species" (H.R. Rep. No. 412, 93rd Cong., 1st Sess. 1973).

Exercising this authority under section 4(d), we have developed a rule that is designed to address the Morro shoulderband snail's specific threats and conservation needs. Although the statute does not require us to make a "necessary and advisable" finding with respect to the adoption of specific prohibitions under section 9, we find that this rule as a whole satisfies the requirement in section 4(d) of the Act to issue regulations deemed necessary and advisable to provide for the conservation of the Morro shoulderband snail. As discussed above under Summary of Biological Status and Threats, we have concluded that the Morro shoulderband snail is likely to become in danger of extinction within the foreseeable future primarily due to the ongoing impacts of development and invasive plants combined with projected impacts from climate change and increasing frequency and severity of wildfire. The provisions of this 4(d) rule promote conservation of the Morro shoulderband snail by encouraging management of the landscape in ways that meet both land management considerations and the conservation needs of the Morro shoulderband snail. The provisions of this rule are one of many tools that we will use to promote the conservation of the Morro shoulderband snail.

### **Provisions of the 4(d) Rule**

This final 4(d) rule provides for the conservation of the Morro shoulderband snail by prohibiting all acts described under section 9(a)(1) of the Act, except take resulting from the activities listed below when conducted within habitats occupied by the Morro shoulderband snail. This final rule to reclassify the Morro shoulderband snail as a threatened species discusses take of individuals through removal or degradation of native habitat as one of the reasons for its decline. It also discusses the effects of more frequent or increased intensity of wildfire events associated with climate change. The specific focus of the exceptions to prohibitions included in this final 4(d)

rule is take directly associated with habitat restoration activities in disturbed or degraded native scrub and chaparral habitats throughout the estimated 2,638-ha (6,520-ac) range of the Morro shoulderband snail, and specific fire hazard reduction activities within the estimated range of the species.

Habitat restoration activities improve the condition and habitat suitability for the Morro shoulderband snail and other constituent scrub and chaparral species. Habitat within the range of the species has been subject to degradation that has reduced its suitability for the Morro shoulderband snail. This degradation is the result of invasion by nonnative plant species, particularly perennial veldt grass, that occurs after clearing of native plant communities or on unmanaged lands post-fire. Perennial veldt grass and other nonnative grass species can serve as ladder fuels and convey fires originating in the wildland-urban interface into the native scrub and chaparral communities that surround the community of Los Osos. Community concern over the frequency and intensity of wildfire is increasing every year with the increased frequency of catastrophic wildfire events in California. Widespread wildfires within the range of the Morro shoulderband snail could result in local extirpations of populations/occurrences of the Morro shoulderband snail and reduce or eliminate the ability of the species to recolonize recovering habitat post-fire, even with management of post-wildfire areas.

This final 4(d) rule sets forth the following exceptions to the prohibitions on incidental take when conducted within the range of the Morro shoulderband snail:

(1) Native habitat restoration activities, inclusive of invasive and/or nonnative species removal, conducted by a conservation organization (*e.g.*, the California Native Plant Society, Audubon Society, the Land Conservancy of San Luis Obispo County) pursuant to a Service-approved management or restoration plan.

(2) Fire hazard reduction activities implemented by the California Department of Forestry and Fire Protection (CALFIRE) in accordance with a Service-approved plan within the range of the Morro shoulderband snail.

Fire hazard reduction activities on legal parcels or other non-Federal land within the range of the species will be exempted from the take prohibitions of section 9(a)(1) of the Act. Anticipated fire reduction treatments include removal of downed, dead, or diseased vegetation, creation of shaded fuel

breaks, and mowing of nonnative grassland. We anticipate that these fire hazard reduction activities will have short-term effects on the Morro shoulderband snail. Implementation of fire hazard reduction activities will reduce the risk of catastrophic wildfires, which otherwise could result in local extirpations of Morro shoulderband snail occurrences/populations. Under the Act, “take” means to harass, harm, pursue, hunt, shoot, wound, kill, trap, capture, or collect, or to attempt to engage in any such conduct. Some of these provisions have been further defined in regulation at 50 CFR 17.3. Take can result knowingly or otherwise, by direct and indirect impacts, intentionally or incidentally. Regulating incidental take would help preserve the species’ remaining populations, slow their rate of decline, and decrease synergistic, negative effects from other threats.

We may issue permits to carry out otherwise prohibited activities, including those described above, involving threatened wildlife under certain circumstances. Regulations governing permits are codified at 50 CFR 17.32. With regard to threatened wildlife, a permit may be issued for the following purposes: For scientific purposes, to enhance propagation or survival, for economic hardship, for zoological exhibition, for educational purposes, for incidental taking, or for special purposes consistent with the purposes of the Act. The statute also contains certain statutory exemptions from the prohibitions, which are found in sections 9 and 10 of the Act.

We recognize the special and unique relationship with our State natural resource agency partners in contributing to conservation of listed species. State agencies often possess scientific data and valuable expertise on the status and distribution of endangered, threatened, and candidate species of wildlife and plants. State agencies, because of their authorities and their close working relationships with local governments and landowners, are in a unique position to assist us in implementing all aspects of the Act. In this regard, section 6 of the Act provides that we shall cooperate to the maximum extent practicable with the States in carrying out programs authorized by the Act. Therefore, any qualified employee or agent of a State conservation agency that is a party to a cooperative agreement with us in accordance with section 6(c) of the Act, who is designated by his or her agency for such purposes, will be able to conduct activities designed to conserve the Morro shoulderband snail

that may result in otherwise prohibited take without additional authorization.

Nothing in this 4(d) rule will change in any way the recovery planning provisions of section 4(f) of the Act, the consultation requirements under section 7 of the Act, or our ability to enter into partnerships for the management and protection of the Morro shoulderband snail. However, interagency cooperation may be further streamlined through planned programmatic consultations for the species between us and other Federal agencies, where appropriate.

### III. Common Name of Listed Entity

As a result of the new data and supportive references noted earlier in this rule, we recognize the change in the common name of the listed entity *Helminthoglypta walkeriana* as the Morro shoulderband snail, without the synonym “banded dune snail.” We include this change in nomenclature for the species under Regulation Promulgation, below.

### Required Determinations

*National Environmental Policy Act (42 U.S.C. 4321 et seq.)*

We have determined that environmental assessments and environmental impact statements, as defined under the authority of the National Environmental Policy Act (NEPA; 42 U.S.C. 4321 *et seq.*), need not be prepared in connection with determining a species’ listing status under the Endangered Species Act. We published a notice outlining our reasons for this determination in the **Federal Register** on October 25, 1983 (48 FR 49244). This position was upheld by the U.S. Court of Appeals for the Ninth Circuit (*Douglas County v. Babbitt*, 48 F.3d 1495 (9th Cir. 1995), cert. denied 516 U.S. 1042 (1996)).

### *Government-to-Government Relationship With Tribes*

In accordance with the President’s memorandum of April 29, 1994 (Government-to-Government Relations with Native American Tribal Governments; 59 FR 22951), Executive Order 13175 (Consultation and Coordination with Indian Tribal Governments), and the Department of the Interior’s manual at 512 DM 2, we readily acknowledge our responsibility to communicate meaningfully with recognized Federal Tribes on a government-to-government basis. In accordance with Secretarial Order 3206 of June 5, 1997 (American Indian Tribal Rights, Federal-Tribal Trust Responsibilities, and the Endangered Species Act), we readily acknowledge

our responsibilities to work directly with Tribes in developing programs for healthy ecosystems, to acknowledge that Tribal lands are not subject to the same controls as Federal public lands, to remain sensitive to Indian culture, and to make information available to Tribes.

We did not receive any comments from Tribes on the proposed rule. We have determined that no Tribes will be affected by this rule because there are no Tribal lands or interests within or adjacent to Morro shoulderband snail habitat.

**References Cited**

A complete list of references cited in this rulemaking is available on the internet at <https://www.regulations.gov> and upon request from the Ventura Fish

and Wildlife Office (see **FOR FURTHER INFORMATION CONTACT**).

**Authors**

The primary authors of this final rule are the staff members of the Fish and Wildlife Service’s Species Assessment Team and the Ventura Fish and Wildlife Office.

**List of Subjects in 50 CFR Part 17**

Endangered and threatened species, Exports, Imports, Reporting and recordkeeping requirements, Transportation.

**Regulation Promulgation**

Accordingly, we amend part 17, subchapter B of chapter I, title 50 of the Code of Federal Regulations, as set forth below:

**PART 17—ENDANGERED AND THREATENED WILDLIFE AND PLANTS**

■ 1. The authority citation for part 17 continues to read as follows:

**Authority:** 16 U.S.C. 1361–1407; 1531–1544; and 4201–4245, unless otherwise noted.

■ 2. Amend § 17.11, in paragraph (h), by removing the entry for “Snail, Morro shoulderband (=Banded dune)” and adding the entry “Snail, Morro shoulderband” in its place under SNAILS in the List of Endangered and Threatened Wildlife to read as follows:

**§ 17.11 Endangered and threatened wildlife.**

\* \* \* \* \*

(h) \* \* \*

Common name	Scientific name	Where listed	Status	Listing citations and applicable rules
*	*	*	*	*
		SNAILS		
Snail, Morro shoulderband.	<i>Helmin thoglypta walkeriana.</i>	Wherever found .....	T	59 FR 64613, 12/15/1994; 87 FR [INSERT FEDERAL REGISTER PAGE WHERE THE DOCUMENT BEGINS], 2/3/2022; 50 CFR 17.45(b); <sup>4d</sup> 50 CFR 17.95(f). <sup>CH</sup>
*	*	*	*	*

■ 3. Amend § 17.45 by adding paragraph (b) to read as follows:

**§ 17.45 Special rules—snails and clams.**

\* \* \* \* \*

(b) Morro shoulderband snail (*Helminthoglypta walkeriana*)—(1) *Prohibitions.* The following prohibitions that apply to endangered wildlife also apply to the Morro shoulderband snail. Except as provided under paragraph (b)(2) of this section and §§ 17.4 and 17.5, it is unlawful for any person subject to the jurisdiction of the United States to commit, to attempt to commit, to solicit another to commit, or cause to be committed, any of the following acts in regard to this species:

- (i) Import or export, as set forth at § 17.21(b) for endangered wildlife.
- (ii) Take, as set forth at § 17.21(c)(1) for endangered wildlife.

(iii) Possession and other acts with unlawfully taken specimens, as set forth at § 17.21(d)(1) for endangered wildlife.

(iv) Interstate or foreign commerce in the course of commercial activity, as set forth at § 17.21(e) for endangered wildlife.

(v) Sale or offer for sale, as set forth at § 17.21(f) for endangered wildlife.

(2) *Exceptions from prohibitions.* In regard to this species, you may:

(i) Conduct activities as authorized by a permit under § 17.32.

(ii) Take, as set forth at § 17.21(c)(2) through (4) for endangered wildlife.

(iii) Take, as set forth at § 17.31(b).

(iv) Take incidental to an otherwise lawful activity caused by:

- (A) Native habitat restoration activities, inclusive of invasive and/or nonnative species removal, conducted

by a conservation organization pursuant to a Service-approved management or restoration plan.

(B) Fire-hazard reduction activities implemented by the California Department of Forestry and Fire Protection in accordance with a Service-approved plan within the range of the Morro shoulderband snail.

(v) Possess and engage in other acts with unlawfully taken wildlife, as set forth at § 17.21(d)(2) for endangered wildlife.

**Martha Williams,**

*Principal Deputy Director, Exercising the Delegated Authority of the Director, U.S. Fish and Wildlife Service.*

[FR Doc. 2022–02008 Filed 2–2–22; 8:45 am]

**BILLING CODE 4333–15–P**

# Proposed Rules

Federal Register

Vol. 87, No. 23

Thursday, February 3, 2022

This section of the FEDERAL REGISTER contains notices to the public of the proposed issuance of rules and regulations. The purpose of these notices is to give interested persons an opportunity to participate in the rule making prior to the adoption of the final rules.

## NATIONAL CREDIT UNION ADMINISTRATION

### 12 CFR Part 701

[NCUA–2022–0016]

RIN 3133–AF42

### Succession Planning

**AGENCY:** National Credit Union Administration (NCUA).

**ACTION:** Proposed rule.

**SUMMARY:** Through this proposed rule, the NCUA Board (Board) would require that Federal Credit Union (FCU) boards of directors establish and adhere to processes for succession planning. The succession plans will help to ensure that the credit union has plans to fill key positions, such as officers of the board, management officials, executive committee members, supervisory committee members, and (where provided for in the bylaws) the members of the credit committee to provide continuity of operations. In addition, the proposed rule would require directors to be knowledgeable about the FCU's succession plan. Although the proposed rule would apply only to FCUs, the Board's purpose is to encourage and strengthen succession planning for all credit unions. The proposed rule would provide FCUs with broad discretion in implementing the proposed regulatory requirements to minimize any burden.

**DATES:** Comments must be received on or before April 4, 2022.

**ADDRESSES:** You may submit comments, by any of the following methods (Please send comments by one method only):

- *Federal eRulemaking Portal:* <https://www.regulations.gov>. The docket number for this proposed rule is NCUA–2021–NCUA–2022–0016 and is available at <https://www.regulations.gov>. Follow the instructions for submitting comments.

- *Fax:* (703) 518–6319. Include “[Your name] Comments on ‘Succession Planning’” in the transmittal.

- *Mail:* Address to Melane Conyers-Ausbrooks, Secretary of the Board, National Credit Union Administration, 1775 Duke Street, Alexandria, Virginia 22314–3428.

- *Hand Delivery/Courier:* Same as mail address.

*Public inspection:* All public comments are available on the Federal eRulemaking Portal at: <https://www.regulations.gov> as submitted, except as may not be possible for technical reasons. Public comments will not be edited to remove any identifying or contact information.

Due to social distancing measures in effect, the usual opportunity to inspect paper copies of comments in the NCUA's law library is not currently available. After social distancing measures are relaxed, visitors may make an appointment to review paper copies by calling (703) 518–6540 or emailing [OGCMail@ncua.gov](mailto:OGCMail@ncua.gov).

**FOR FURTHER INFORMATION CONTACT:** Ariel Pereira, Senior Staff Attorney, Office of General Counsel, at (703) 548–2778; or by mail at National Credit Union Administration, 1775 Duke Street, Alexandria, Virginia 22314.

#### SUPPLEMENTARY INFORMATION:

#### Table of Contents

- I. Background
  - A. Succession Planning
  - B. Increased Relevance of Succession Planning
- II. Legal Authority
- III. This Proposed Rule
  - A. Applicability of Proposed Rule
  - B. Proposed Regulatory Amendments
  - C. Current Succession Planning Efforts
  - D. Minimizing Burden
  - E. Questions for Comment
- IV. Regulatory Procedures
  - A. Regulatory Flexibility Act
  - B. Paperwork Reduction Act
  - C. Executive Order 13132 on Federalism
  - D. Assessment of Federal Regulations and Policies on Families

#### I. Background

##### A. Succession Planning

Board members play a key role in a credit union's success.<sup>1</sup> The Federal

<sup>1</sup> Unless otherwise specified, the term “credit union” as used in this preamble refers to all federally insured credit unions, whether federally or state chartered. As noted in this preamble, the proposed regulatory amendments would apply only to FCUs; however, the Board's intent in issuing the proposed rule is to encourage and strengthen succession planning for all federally insured credit unions.

Credit Union Act (FCU Act) vests the general direction and control of an FCU to its board.<sup>2</sup> Credit union boards are faced with a multitude of complicated challenges, such as meeting evolving member needs, fostering employee loyalty and trust, retaining and developing necessary skills, and keeping pace with technological and industry changes. Among this list of issues, succession planning is one of the most critical.

Succession planning is the process through which an organization helps identify, develop, and retain key personnel to ensure its viability and continued effective performance. It also allows an organization to prepare for the unexpected, including the sudden departure of key staff. Succession planning is recognized as vital to the success of any institution, including credit unions. One of the variables over which a credit union board has control is the hiring of the organization's senior management. A board's failure to plan for the transition of its management could potentially come with high costs, including the potential for the unplanned merger of the credit union upon the departure of key personnel.

Conversely, good succession planning confers a variety of benefits, including:

- Minimizing service disruptions during management transitions;
- Ensuring organizational viability over the long term;
- Clarifying the employee development path;
- Developing current talent;
- Creating opportunities for employees; and
- Bringing in new ideas from outside hires.

Succession planning is a critical component of a credit union's overall strategic plan. It ensures that the appropriate personnel are available to execute the credit union's strategic plan and mission. As noted, the goal of succession planning is to build and/or identify a pool of qualified individuals who can be recruited or selected to fill a vacancy in a key position. To be successful, succession planning should be an ongoing and iterative process, not a one-time event.

<sup>2</sup> 12 U.S.C. 1761b; 12 CFR 701.4, and Article VI, section 6 of the Federal Credit Union Bylaws codified in Appendix A of 12 CFR part 701.

### B. Increased Relevance of Succession Planning

Several factors have contributed to increase the relevance of succession planning for credit union boards. First, there has been a decline in the number of credit unions mainly resulting from the long-running trend of consolidation across all depository institutions. This trend has remained relatively constant across all economic cycles for more than three decades.

During the third quarter of 2021, the number of FICUs increased in every asset category tracked by the NCUA, except for those with less than \$50 million in assets.<sup>3</sup> The number of FICUs with assets of at least \$10 million but less than \$50 million declined to 1,467 in the third quarter of 2021 from 1,561 in the third quarter of 2020 (a decline of 94 credit unions).<sup>4</sup> The decline in the number of FICUs with less than \$10 million in assets was even greater. The number of FICUs with less than \$10 million in assets declined to 1,068 in the third quarter of 2021 from 1,199 in the third quarter of 2020 (a decline of 131 credit unions).<sup>5</sup> The available data does not differentiate between those smaller credit unions that consolidated or were liquidated, versus those that expanded into a larger asset category. However, the decrease in the total number of FICUs with less than \$50 million in assets (especially those with assets of less than \$10 million), combined with the ongoing industry trend of consolidation, suggests that mergers may be more prevalent among smaller credit unions.

One of the reasons for the consolidation is the lack of succession planning. An NCUA analysis found that poor management succession planning was either a primary or secondary reason for almost a third (32 percent) of credit union consolidations.<sup>6</sup>

The FCU Act contains provisions that disfavor consolidation, implying a presumption that the public is better served with a greater number of credit unions. For example, the statute imposes added limitations on the addition of larger groups to multiple common-bond credit unions, prompting the Board to consider the feasibility of formation of a separate credit union.<sup>7</sup>

<sup>3</sup> NCUA, *Financial Trends in Federally Insured Credit Unions Q3*, page iii, available at: <https://www.ncua.gov/files/publications/analysis/quarterly-data-summary-2021-Q3.pdf>.

<sup>4</sup> *Id.*

<sup>5</sup> *Id.*

<sup>6</sup> NCUA, *Truth in Mergers: A Guide for Merging Credit Unions*, page 9, available at: <https://www.ncua.gov/files/publications/Truth-In-Mergers.pdf>.

<sup>7</sup> 12 U.S.C. 1759(d)(1).

Further, the FCU Act provides that the Board shall “encourage the formation of separately chartered credit unions instead of approving an application to include an additional group within the field of membership of an existing credit union whenever practicable and consistent with reasonable standards for the safe and sound operation of the credit union.”<sup>8</sup>

Another reason for a heightened focus on succession planning is the ongoing retirements of the so-called “Baby Boomer” generation (individuals born between 1946 and 1964). These individuals comprise more than a quarter of the total population of the United States.<sup>9</sup> Each day, commencing in 2011 (when the oldest members of the generation turned 65) and continuing until 2030, approximately 10,000 Baby Boomers will turn age 65.<sup>10</sup> The COVID-19 pandemic has accelerated the pace of retirements among this generational cohort.<sup>11</sup> These retirements include credit union board members and executives. According to some sources, approximately 10 percent of credit union chief executive officers were expected to retire between 2019 and 2021.<sup>12</sup> Succession planning is critical to the continued operation of those credit unions with board members and executives that are part of this retirement wave.

### II. Legal Authority

The Board is issuing this proposed rule pursuant to its authority under the FCU Act. The proposed rule would establish succession planning requirements for an FCU. Section 113 of the FCU Act provides that the board of directors shall have the general direction and control of the affairs of the FCU.<sup>13</sup> The board of directors must oversee the credit union’s operations to ensure the credit union operates in a safe and sound manner. For example, the board must be kept informed about the credit union’s operating environment, hire and retain competent management, and ensure that the credit

<sup>8</sup> 12 U.S.C. 1759(f).

<sup>9</sup> Russell Heimlich, *Baby Boomers Retire*, Pew Research Center (December 20, 2010) <https://www.pewresearch.org/fact-tank/2010/12/29/baby-boomers-retire/>.

<sup>10</sup> *Id.*

<sup>11</sup> Richard Fry, *The Pace of Boomer Retirements Has Accelerated in the Past Year*, Pew Research Center (November 9, 2020) <https://www.pewresearch.org/fact-tank/2020/11/09/the-pace-of-boomer-retirements-has-accelerated-in-the-past-year/>.

<sup>12</sup> *CUToday.info*, *CUNA ACUC Coverage: What’s Happening in Executive Compensation* (June 19, 2019) <https://www.cutoday.info/Fresh-Today/CUNA-ACUC-Coverage-What-s-Happening-in-Executive-Compensation>.

<sup>13</sup> 12 U.S.C. 1716b.

union has a risk management structure and process suitable for the credit union’s size and activities.

Further, under the FCU Act, the NCUA is the chartering and supervisory authority for FCUs and the Federal supervisory authority for FICUs.<sup>14</sup> The FCU Act grants the NCUA a broad mandate to issue regulations governing both FCUs and all FICUs. Section 120 of the FCU Act is a general grant of regulatory authority and authorizes the Board to prescribe rules and regulations for the administration of the FCU Act.<sup>15</sup> Section 207 of the FCU Act is a specific grant of authority over share insurance coverage, conservatorships, and liquidations.<sup>16</sup> Section 209 of the FCU Act is a plenary grant of regulatory authority to the Board to issue rules and regulations necessary or appropriate to carry out its role as share insurer for all FICUs.<sup>17</sup> Accordingly, the FCU Act grants the Board broad rulemaking authority to ensure that the credit union industry and the NCUSIF remain safe and sound.

### III. This Proposed Rule

#### A. Applicability of Proposed Rule

As described in more detail in the following discussion, the proposed regulatory amendments would apply solely to FCUs. FISCUs must comply with any state-specific requirements pertaining to succession planning. However, the Board encourages FISCO boards, to the extent compatible with state law, to undertake succession planning efforts to help ensure continued viability of their credit union.

In addition, the proposed rule would not amend the regulations in 12 CFR part 704, which establishes requirements applicable to federally insured corporate credit unions, since the Board believes these regulations already adequately address succession planning. For example, § 704.13(c)(1) requires that the board must ensure that “[s]enior managers . . . are capable of identifying, hiring, and retaining qualified staff.” Further, paragraph (c)(2) of the section requires that the board also ensure that “[q]ualified personnel are employed or under contract for all line support and audit areas, and designated back-up personnel or resources with adequate cross-training are in place.” The Board welcomes public comment on whether changes to the wording of § 704.13 are necessary to effectuate the purposes of the proposed regulatory amendments.

<sup>14</sup> 12 U.S.C. 1752–1775.

<sup>15</sup> 12 U.S.C. 1766(a).

<sup>16</sup> 12 U.S.C. 1787(b)(1).

<sup>17</sup> 12 U.S.C. 1789(a)(11).

The proposed rule applies to all FCUs, irrespective of asset size. However, as discussed above, smaller credit unions may be more susceptible to consolidation. Further, data demonstrates that the lack of succession planning is a major cause of credit union mergers.<sup>18</sup> Accordingly, smaller credit unions may be the most likely to benefit from the proposed rule. The Board specifically invites comment from smaller credit unions on the proposed regulatory amendments, as well as other suggestions, to improve credit union succession planning.

#### B. Proposed Regulatory Amendments

The proposed rule would amend § 701.4, which sets forth the general duties and responsibilities of FCU directors. The proposal would add a new paragraph (e) requiring that FCU directors must establish and adhere to processes for succession planning for key positions. In specifying the officials covered by the succession plan, the Board has relied on the language of the FCU Act, which provides that “[t]he management of a Federal credit union shall be by a board of directors, a supervisory committee, and where the bylaws so provide, a credit committee.”<sup>19</sup> The FCU bylaws codified in Appendix A of 12 CFR part 701 expand the list of senior FCU executives to include the members of an executive committee and management officials.

The board of directors or an appropriate committee of the board would be required to review and approve a written succession plan regarding the specified FCU executives and officials. The succession plan must, at a minimum, identify the credit union’s key positions, necessary competencies and skill sets for those positions, and strategies to identify alternatives to fill vacancies. The board of directors must review the succession plan in accordance with a schedule established by the board, but no less than annually.

In addition, the proposed rule would amend § 701.4(b)(3), which sets forth certain education requirements for FCU directors, to require that directors have a working familiarity with the FCU’s succession plan. In making this change, the Board also proposes to reorganize the current contents of paragraph (b)(3) for clarity and grammar. No substantive changes are proposed to the current requirements of § 701.4(b)(3).

#### C. Current Succession Planning Efforts

This proposed rule is intended to strengthen current succession planning efforts being taken by credit unions, and to require others that have not yet done so to commence their succession planning process. The proposed rule is also consistent with the guidance issued by the other banking agencies to address succession planning.<sup>20</sup>

The Board is aware that many credit unions have already adopted succession planning strategies and models. The NCUA offers training and other resources to aid credit unions in developing their succession plans. For example, the NCUA has posted a video series on succession planning on the internet.<sup>21</sup> In addition, the Board’s 2019 final rule on FCU bylaws promoted succession planning efforts by providing guidance to FCUs on associate director positions.<sup>22</sup> The proposed rule clarified, through staff commentary, that these positions may be thought of as apprenticeships in which the incumbent receives training and knowledge about the business of the board, with the expectation that the experience will prepare the individual for an eventual election to a director position.<sup>23</sup>

#### D. Minimizing Burden

In designing this proposed rule, the Board has endeavored to minimize the burden on FCUs, especially small FCUs. The proposed regulatory amendments provide FCUs with broad discretion in how to implement the new requirements. For example, while the proposed rule would require succession plans to include certain mandatory elements, the rule neither specifies how the topics should be addressed nor does it otherwise prescribe the contents of the succession plans. Similarly, the proposal would require that directors have a working familiarity with the FCU’s succession plan but does not mandate the contents of training to meet this requirement.

The expectation is for credit unions to develop a plan and provide training that is consistent with the size and complexity of the credit union. Therefore, smaller credit unions are

more likely to have a simple succession plan that only addresses a few key leadership positions. The Board envisions that the examination program would confirm the existence of a succession plan and training. The examination program will defer to a credit union’s self-assessment of its succession planning needs and the information contained in the plan, so long as its plan addresses the elements required by the rule.

Further, the Board envisions that, as a result of other planning and documentation efforts, many FCUs already have the necessary data and information to complete their succession plans. Rather than undertaking new analysis specifically for the succession plan, FCUs are encouraged to use already existing information in preparing their plans. For example, under the NCUA guidelines codified in 12 CFR part 749, Appendix B, all federally insured credit unions are encouraged to develop a program to prepare for a catastrophic act. The codified guidelines suggest that the program address several elements that are also relevant to succession planning. These suggested elements include a “business impact analysis to evaluate potential threats,” the determination of “critical systems and necessary resources,” and the identification of the “[p]ersons with authority to enact the plan.”

The Board is committed to assisting credit unions in implementing their succession plans. For example, the NCUA has posted online training on succession planning through its Learning Management System.<sup>24</sup> In addition, credit union trade associations may also provide training and have guidance available to assist credit unions in the development of their succession plan process. Credit unions with low-income designation may be able to apply for technical assistance grants to support succession planning or offset training costs through the Community Development Revolving Loan Fund. Credit unions are encouraged to make use of these and other available resources in complying with the proposed rule. The NCUA will develop additional guidance, as it deems necessary, to aid credit union succession planning efforts.

#### E. Questions for Comment

The Board welcomes comments on all aspects of this proposed rule. It is especially interested in comments addressing ways the NCUA may better support succession planning in small

<sup>20</sup> See e.g., Federal Reserve Board, *Supervisory Guidance on Board of Directors’ Effectiveness* (Feb. 26, 2021); also the guidelines of the Office of the Comptroller of the Currency (OCC) at 12 CFR part 30, Appendix D, captioned “OCC Guidelines Establishing Heightened Standards for Certain Large Insured National Banks, Insured Federal Savings Associations, and Insured Federal Branches.”

<sup>21</sup> NCUA, *Succession Planning (2021)*, [https://ncua.csod.com/LMS/catalog/Welcome.aspx?tab\\_page\\_id=-67&tab\\_id=221000382](https://ncua.csod.com/LMS/catalog/Welcome.aspx?tab_page_id=-67&tab_id=221000382).

<sup>22</sup> 84 FR 53278 (Oct. 4, 2019).

<sup>23</sup> *Id.* at 53301.

<sup>24</sup> *Supra*, note 21.

<sup>18</sup> *Supra*, note 6.

<sup>19</sup> 12 U.S.C. 1761.

credit unions and suggestions on ways the final rule might minimize burden. In particular, the Board requests public input on the following questions:

1. What do you believe will be the quantified burden imposed by the rule, be it in hours, dollars, or effort?

2. It is anticipated that most FCUs already possess the information needed to comply with the proposed rule, and thus that most FCU will not have to create any new documentation as a result of the rule. Do you agree with this view? Why or why not?

3. As noted, the Board anticipates that the examination program will establish an FCU's compliance with the proposed rule by confirming the existence of a succession plan and training. Do you have any other suggested methods of establishing compliance?

4. This preamble provides that smaller credit unions with less than \$10 million in assets will be the primary beneficiaries of the proposed rule. What benefits do you think smaller credit unions will receive from the Board's adoption of this proposed rule?

5. What benefits do you anticipate larger FCUs will receive from adoption of the proposed rule? For purposes of this question, "larger FCUs" may include FCUs with more than \$10 million in assets or FCUs in another higher asset category.

6. What benefits do you anticipate members will receive from the adoption of the proposed rule?

7. What impact do you believe this rule will have on credit union consolidations?

8. The NCUA believes that the proposed rule will result in benefits for the National Credit Union Share Insurance Fund, to the overall safety and soundness of the credit union system, and to FCU members. If the rule is adopted as is, what would you suggest the NCUA do to test the assumption above?

9. The NCUA reviews all of its existing regulations every three years. The NCUA's Office of General Counsel maintains a rolling review schedule that identifies one-third of the NCUA's existing regulations for review each year and provides notice to the public of those regulations under review so the public may have an opportunity to comment.<sup>25</sup> In addition, should the NCUA commit to revisiting this rule within a specific period, say after 7 years, at which time the rule would either be rescinded or approved by the Board for renewal? The Board might

also choose, at that time to renew the rule but with some revisions.

#### IV. Regulatory Procedures

##### A. Regulatory Flexibility Act

The Regulatory Flexibility Act requires the NCUA to prepare an analysis to describe any significant economic impact a regulation may have on a substantial number of small entities.<sup>26</sup> For purposes of this analysis, the NCUA considers small credit unions to be those having under \$100 million in assets.<sup>27</sup> The Board fully considered the potential economic impacts of the proposed succession planning requirements on small credit unions during the development of the proposed rule. As noted in the preamble, the proposed rule would provide FCUs with discretion in how to implement the new regulatory requirements. For example, the rule does not specify how specific succession plan topics should be addressed. Similarly, the proposal does not mandate the contents of succession plan training. Accordingly, the NCUA certifies that it would not have a significant economic impact on a substantial number of small credit unions.

##### B. Paperwork Reduction Act

The Paperwork Reduction Act of 1995 (PRA) applies to rulemakings in which an agency by rule creates a new paperwork burden on regulated entities or amends an existing burden.<sup>28</sup> For purposes of the PRA, a paperwork burden may take the form of a reporting, disclosure, or recordkeeping requirement, each referred to as an information collection. The proposed changes to part 701 would establish new information collections in the form of succession policies, plans, and related trainings. These revisions will be addressed in a separate **Federal Register** notice and will be submitted for approval by the Office of Information and Regulatory Affairs at the Office of Management and Budget.

##### C. Executive Order 13132 on Federalism

Executive Order 13132<sup>29</sup> encourages independent regulatory agencies to consider the impact of their actions on state and local interests. The NCUA, an independent regulatory agency, as defined in 44 U.S.C. 3502(5), voluntarily complies with the executive order to

<sup>26</sup> 5 U.S.C. 603(a).

<sup>27</sup> 80 FR 57512 (Sept. 24, 2015).

<sup>28</sup> 44 U.S.C. 3501–3520.

<sup>29</sup> Executive Order 13132 on Federalism, was signed by former President Clinton on August 4, 1999, and subsequently published in the **Federal Register** on August 10, 1999 (64 FR 43255).

adhere to fundamental federalism principles. The proposed rule would not have substantial direct effects on the states, on the relationship between the national government and the states, or on the distribution of power and responsibilities among the various levels of government. The Board has therefore determined that this rule does not constitute a policy that has federalism implications for purposes of the executive order.

##### D. Assessment of Federal Regulations and Policies on Families

The NCUA has determined that this proposed rule would not affect family well-being within the meaning of Section 654 of the Treasury and General Government Appropriations Act, 1999.<sup>30</sup>

##### List of Subjects in 12 CFR Part 701

Advertising, Aged, Civil rights, Credit, Credit unions, Fair housing, Individuals with disabilities, Insurance, Marital status discrimination, Mortgages, Religious discrimination, Reporting and recordkeeping requirements, Sex discrimination, Signs and symbols, Surety bonds.

By the National Credit Union Administration Board on January 27, 2022.

**Melane Conyers-Ausbrooks,**  
*Secretary of the Board.*

For the reasons stated in the preamble, the NCUA proposes to amend 12 CFR part 701, as follows:

#### PART 701—ORGANIZATION AND OPERATION OF FEDERAL CREDIT UNION

■ 1. The authority for part 701 continues to read as follows:

**Authority:** 12 U.S.C. 1752(5), 1755, 1756, 1757, 1758, 1759, 1761a, 1761b, 1766, 1767, 1782, 1784, 1785, 1786, 1787, 1789. Section 701.6 is also authorized by 15 U.S.C. 3717. Section 701.31 is also authorized by 15 U.S.C. 1601 *et seq.*; 42 U.S.C. 1981 and 3601–3610. Section 701.35 is also authorized by 42 U.S.C. 4311–4312.

■ 2. Amend § 701.4 by:

- a. Revising paragraph (b)(3).
- b. Adding paragraph (e).

The addition and revision to read as follows:

##### § 701.4 General authorities and duties of Federal credit union directors.

\* \* \* \* \*

(b) \* \* \*

(3) At the time of election or appointment, or within a reasonable time thereafter, not to exceed six months, have at least a working

<sup>30</sup> Public Law 105–277, 112 Stat. 2681 (1998).

<sup>25</sup> See, <https://www.ncua.gov/regulation-supervision/rules-regulations/regulatory-review>.



familiarity with, and to ask, as appropriate, substantive questions of management and the internal and external auditors of:

(i) Basic finance and accounting practices, including the ability to read and understand the Federal credit union's balance sheet and income statement; and

(ii) The Federal credit union's succession plan established pursuant to paragraph (e) of this section.

\* \* \* \* \*

(e) *Succession planning.* (1) *General.* A Federal credit union board of directors must establish a process to ensure proper succession planning to include officers of the board, management officials, executive committee members, supervisory committee members, and (where provided for in the bylaws) the members of the credit committee, as described in Appendix A.

(2) *Board responsibilities.* The board of directors or an appropriate committee of the board must:

(i) Approve a written succession plan that covers the individuals described in paragraph (e)(1) of this section; and

(ii) Review, and update as deemed necessary, the succession plan and policy in accordance with a schedule established by the board of directors, but no less than annually.

(3) *Succession plan contents.* The succession plan must, at a minimum, identify key positions covered by the plan, necessary general competencies and skills for those positions, and strategies to identify alternatives to fill vacancies.

[FR Doc. 2022-02038 Filed 2-2-22; 8:45 am]

BILLING CODE 7535-01-P

## DEPARTMENT OF TRANSPORTATION

### Federal Aviation Administration

#### 14 CFR Part 39

[Docket No. FAA-2022-0085; Project Identifier MCAI-2021-00498-T]

RIN 2120-AA64

#### Airworthiness Directives; Bombardier, Inc., Airplanes

**AGENCY:** Federal Aviation Administration (FAA), DOT.

**ACTION:** Notice of proposed rulemaking (NPRM).

**SUMMARY:** The FAA proposes to adopt a new airworthiness directive (AD) for certain Bombardier, Inc., Model BD-700-1A10 and BD-700-1A11 airplanes. This proposed AD was prompted by

reports of oxygen leaks caused by cracked, brittle, or broken oxygen hoses that were found during scheduled maintenance tests of the airplane oxygen system. This proposed AD would require an inspection of the oxygen hose assembly to determine if an affected part number is installed, and replacement of affected oxygen hoses. For certain airplanes, this proposed AD would allow repetitive testing of the oxygen system until affected hoses are replaced. This proposed AD would also prohibit installation of an affected oxygen hose. The FAA is proposing this AD to address the unsafe condition on these products.

**DATES:** The FAA must receive comments on this proposed AD by March 21, 2022.

**ADDRESSES:** You may send comments, using the procedures found in 14 CFR 11.43 and 11.45, by any of the following methods:

- *Federal eRulemaking Portal:* Go to <https://www.regulations.gov>. Follow the instructions for submitting comments.

- *Fax:* 202-493-2251.

- *Mail:* U.S. Department of Transportation, Docket Operations, M-30, West Building Ground Floor, Room W12-140, 1200 New Jersey Avenue SE, Washington, DC 20590.

- *Hand Delivery:* Deliver to Mail address above between 9 a.m. and 5 p.m., Monday through Friday, except Federal holidays.

For service information identified in this NPRM, contact Bombardier Business Aircraft Customer Response Center, 400 Côte-Vertu Road West, Dorval, Québec H4S 1Y9, Canada; telephone 514-855-2999; email [ac.yul@aero.bombardier.com](mailto:ac.yul@aero.bombardier.com); internet <https://www.bombardier.com>. You may view this service information at the FAA, Airworthiness Products Section, Operational Safety Branch, 2200 South 216th St., Des Moines, WA. For information on the availability of this material at the FAA, call 206-231-3195.

#### Examining the AD Docket

You may examine the AD docket at <https://www.regulations.gov> by searching for and locating Docket No. FAA-2022-0085; or in person at Docket Operations between 9 a.m. and 5 p.m., Monday through Friday, except Federal holidays. The AD docket contains this NPRM, any comments received, and other information. The street address for Docket Operations is listed above.

**FOR FURTHER INFORMATION CONTACT:** Elizabeth Dowling, Aerospace Engineer, Mechanical Systems and Administrative Services Section, FAA, New York ACO Branch, 1600 Stewart Avenue, Suite 410, Westbury, NY 11590; telephone

516-228-7300; fax 516-794-5531; email [9-avs-nyaco-cos@faa.gov](mailto:9-avs-nyaco-cos@faa.gov).

#### SUPPLEMENTARY INFORMATION:

##### Comments Invited

The FAA invites you to send any written relevant data, views, or arguments about this proposal. Send your comments to an address listed under **ADDRESSES**. Include "Docket No. FAA-2022-0085; Project Identifier MCAI-2021-00498-T" at the beginning of your comments. The most helpful comments reference a specific portion of the proposal, explain the reason for any recommended change, and include supporting data. The FAA will consider all comments received by the closing date and may amend the proposal because of those comments.

Except for Confidential Business Information (CBI) as described in the following paragraph, and other information as described in 14 CFR 11.35, the FAA will post all comments received, without change, to <https://www.regulations.gov>, including any personal information you provide. The agency will also post a report summarizing each substantive verbal contact received about this NPRM.

##### Confidential Business Information

CBI is commercial or financial information that is both customarily and actually treated as private by its owner. Under the Freedom of Information Act (FOIA) (5 U.S.C. 552), CBI is exempt from public disclosure. If your comments responsive to this NPRM contain commercial or financial information that is customarily treated as private, that you actually treat as private, and that is relevant or responsive to this NPRM, it is important that you clearly designate the submitted comments as CBI. Please mark each page of your submission containing CBI as "PROPIN." The FAA will treat such marked submissions as confidential under the FOIA, and they will not be placed in the public docket of this NPRM. Submissions containing CBI should be sent to Elizabeth Dowling, Aerospace Engineer, Mechanical Systems and Administrative Services Section, FAA, New York ACO Branch, 1600 Stewart Avenue, Suite 410, Westbury, NY 11590; telephone 516-228-7300; fax 516-794-5531; email [9-avs-nyaco-cos@faa.gov](mailto:9-avs-nyaco-cos@faa.gov). Any commentary that the FAA receives which is not specifically designated as CBI will be placed in the public docket for this rulemaking.

##### Background

Transport Canada Civil Aviation (TCCA), which is the aviation authority

for Canada, has issued TCCA AD CF–2021–17, dated April 28, 2021 (also referred to after this as the Mandatory Continuing Airworthiness Information, or the MCAI), to correct an unsafe condition for certain Bombardier, Inc., Model BD–700–1A10 and BD–700–1A11 airplanes. You may examine the MCAI in the AD docket at <https://www.regulations.gov> by searching for and locating Docket No. FAA–2022–0085.

This proposed AD was prompted by reports of oxygen leaks caused by cracked, brittle, or broken oxygen hoses that were found during scheduled maintenance tests of the airplane oxygen system. The FAA is proposing this AD to prevent a leak in the oxygen line, which may result in failure to provide oxygen to passengers and crew and result in an oxygen-enriched atmosphere creating a fire risk on the airplane. See the MCAI for additional background information.

**Related Service Information Under 1 CFR Part 51**

Bombardier has issued the following service information.

- Bombardier Service Bulletin 700–1A11–35–014, Revision 01, dated February 12, 2021.
- Bombardier Service Bulletin 700–35–015, Revision 01, dated February 12, 2021.
- Bombardier Service Bulletin 700–35–5005, Revision 01, dated February 12, 2021.
- Bombardier Service Bulletin 700–35–6005, Revision 01, dated February 12, 2021.
- Bombardier Service Bulletin 700–35–6501, Revision 01, dated February 12, 2021.

This service information describes procedures for doing an inspection of the oxygen hose assembly installations to determine if a part number within the series O2C20T1 is installed, and replacing the oxygen hose if necessary. For certain airplanes, the service information specifies optional repetitive testing of the oxygen system that would allow for delay of the replacement. These documents are distinct since they apply to different airplane serial numbers.

This service information is reasonably available because the interested parties have access to it through their normal course of business or by the means identified in the **ADDRESSES** section.

**FAA’s Determination**

This product has been approved by the aviation authority of another country, and is approved for operation in the United States. Pursuant to the FAA’s bilateral agreement with the State of Design Authority, the FAA has been notified of the unsafe condition described in the MCAI and service information referenced above. The FAA is proposing this AD because the FAA evaluated all the relevant information and determined the unsafe condition described previously is likely to exist or develop on other products of the same type design.

**Proposed AD Requirements in This NPRM**

This proposed AD would require accomplishing the actions specified in the service information already described. This proposed AD would also prohibit installation of an affected oxygen hose.

**Costs of Compliance**

The FAA estimates that this AD, if adopted as proposed, would affect 409 airplanes of U.S. registry. The FAA estimates the following costs to comply with this proposed AD:

**ESTIMATED COSTS FOR REQUIRED ACTIONS**

Labor cost	Parts cost	Cost per product	Cost on U.S. operators
Up to 36 work-hours × \$85 per hour = Up to \$3,060	\$0	Up to \$3,060 .....	Up to \$1,251,540.

**ESTIMATED COSTS FOR OPTIONAL ACTIONS**

Labor cost	Parts cost	Cost per product
Up to 25 work-hours × \$85 per hour = Up to \$2,125 .....	Up to \$125 .....	Up to \$2,250.

The FAA has included all known costs in its cost estimate. According to the manufacturer, however, some or all of the costs of this proposed AD may be covered under warranty, thereby reducing the cost impact on affected operators.

**Authority for This Rulemaking**

Title 49 of the United States Code specifies the FAA’s authority to issue rules on aviation safety. Subtitle I, section 106, describes the authority of the FAA Administrator. Subtitle VII: Aviation Programs, describes in more detail the scope of the Agency’s authority.

The FAA is issuing this rulemaking under the authority described in Subtitle VII, Part A, Subpart III, Section 44701: General requirements. Under

that section, Congress charges the FAA with promoting safe flight of civil aircraft in air commerce by prescribing regulations for practices, methods, and procedures the Administrator finds necessary for safety in air commerce. This regulation is within the scope of that authority because it addresses an unsafe condition that is likely to exist or develop on products identified in this rulemaking action.

**Regulatory Findings**

The FAA determined that this proposed AD would not have federalism implications under Executive Order 13132. This proposed AD would not have a substantial direct effect on the States, on the relationship between the national Government and the States, or on the distribution of power and

responsibilities among the various levels of government.

For the reasons discussed above, I certify this proposed regulation:

(1) Is not a “significant regulatory action” under Executive Order 12866,

(2) Would not affect intrastate aviation in Alaska, and

(3) Would not have a significant economic impact, positive or negative, on a substantial number of small entities under the criteria of the Regulatory Flexibility Act.

**List of Subjects in 14 CFR Part 39**

Air transportation, Aircraft, Aviation safety, Incorporation by reference, Safety.

**The Proposed Amendment**

Accordingly, under the authority delegated to me by the Administrator, the FAA proposes to amend 14 CFR part 39 as follows:

**PART 39—AIRWORTHINESS DIRECTIVES**

- 1. The authority citation for part 39 continues to read as follows:

**Authority:** 49 U.S.C. 106(g), 40113, 44701.

**§ 39.13 [Amended]**

- 2. The FAA amends § 39.13 by adding the following new airworthiness directive:

**Bombardier, Inc.:** Docket No. FAA–2022–0085; Project Identifier MCAI–2021–00498–T.

**(a) Comments Due Date**

The FAA must receive comments on this airworthiness directive (AD) by March 21, 2022.

**(b) Affected ADs**

None.

**(c) Applicability**

This AD applies to Bombardier, Inc., Model BD–700–1A10 and BD–700–1A11 airplanes, certificated in any category, serial numbers 9002 through 9879 inclusive and 9998.

**(d) Subject**

Air Transport Association (ATA) of America Code 35, Oxygen.

**(e) Unsafe Condition**

This AD was prompted by reports of oxygen leaks caused by cracked, brittle or broken oxygen hoses that were found during scheduled maintenance tests of the airplane oxygen system. The FAA is issuing this AD to address a leak in the oxygen line, which may result in failure to provide oxygen to

passengers and crew and result in an oxygen enriched atmosphere creating a fire risk on the airplane.

**(f) Compliance**

Comply with this AD within the compliance times specified, unless already done.

**(g) Inspection and Replacement**

Within 6 months after the effective date of this AD: Do an inspection of the oxygen hose assembly to determine if any hose having a part number (P/N) in the O2C20T1 series is installed, in accordance with the Accomplishment Instructions of the applicable service information specified in figure 1 to paragraph (g) of this AD. If P/N O2C20T1 series is installed, or if any test fails as specified in paragraph (h) of this AD: Before further flight, replace all the oxygen hoses, in accordance with the Accomplishment Instructions of the applicable service information specified in figure 1 to paragraph (g) of this AD.

**BILLING CODE 4910–13–P**

**Figure 1 to paragraph (g) – Service Information**

<b>Model–</b>	<b>Serial Numbers–</b>	<b>Bombardier Service Bulletin–</b>
BD-700-1A10 airplanes	9002 through 9005 inclusive, 9007 through 9014 inclusive, 9016 through 9020 inclusive, 9022 through 9026 inclusive, 9028 through 9033 inclusive, 9035, 9036, 9038 through 9051 inclusive, 9053 through 9055 inclusive, 9058 through 9080 inclusive, 9082 through 9106 inclusive, 9108 through 9122 inclusive, 9124 through 9129 inclusive, 9133, 9134, 9136 through 9171 inclusive, 9175, 9179 through 9286 inclusive, 9290 through 9312 inclusive, 9314 through 9354 inclusive, 9357, and 9360 through 9429 inclusive	700-35-015, Revision 01, dated February 12, 2021
BD-700-1A10 airplanes	9381, 9432 through 9491 inclusive, 9496 through 9505 inclusive, 9507 through 9515 inclusive, 9518 through 9525 inclusive, 9527 through 9619 inclusive, 9622 through 9654 inclusive, 9657 through 9673 inclusive, 9677, 9680 through 9684 inclusive, 9686 through 9712 inclusive, 9716 through 9742 inclusive, 9744 through 9785 inclusive, 9788 through 9853 inclusive, 9856 through 9867 inclusive, 9870, 9873 through 9878 inclusive	700-35-6005, Revision 01, dated February 12, 2021
BD-700-1A10 airplanes	9861 and 9872	700-35-6501 Revision 01, dated February 12, 2021
BD-700-1A11 airplanes	9130 through 9209 inclusive, 9212 through 9305 inclusive, 9311 through 9359 inclusive, 9366 through 9430 inclusive, and 9998	700-1A11-35-014, Revision 01, dated February 12, 2021
BD-700-1A11 airplanes	9386, 9401 through 9613 inclusive, and 9618 through 9879 inclusive	700-35-5005, Revision 01, dated February 12, 2021

**(h) Optional Interim Testing for Certain Airplanes**

For airplanes identified in figure 2 of paragraph (h) of this AD: The oxygen hose replacement, if required by paragraph (g) of this AD, may be delayed if all conditions specified in paragraphs (h)(1) through (3) of this AD are met.

(1) The oxygen system is tested at the applicable times specified in paragraph

(h)(1)(i) or (ii) of this AD, in accordance with the Accomplishment Instructions of the applicable service information specified in figure 2 to paragraph (h) of this AD.

(i) If the Aircraft Completion Center Supplemental Type Certificate (STC) for the passenger cabin interior was issued within 5 years before the effective date of this AD: The oxygen system is tested within 6 months after the effective date of this AD, and thereafter at intervals not to exceed 30 months.

(ii) If the Aircraft Completion Center STC for the passenger cabin interior was issued 5 years or more before the effective date of this AD: The oxygen system is tested within 6 months after the effective date of this AD, and thereafter at intervals not to exceed 15 months.

(2) All P/N O2C20T1 series hoses are replaced before further flight as specified in paragraph (g) of this AD after any hose fails any test.

(3) Except as specified by paragraph (h)(2) of this AD, all P/N O2C20T1 series hoses are replaced within 10 years after issuance of the Aircraft Completion Center STC for the

passenger cabin interior as specified in paragraph (g) of this AD provided that all P/N O2C20T1 series hoses in the flight compartment and the third crew (left-hand

side enclosure) are replaced within 6 months after the effective date of this AD.

**Figure 2 to paragraph (h) – Service Information for Optional Interim Testing**

<b>Model—</b>	<b>Serial Numbers—</b>	<b>Bombardier Service Bulletin—</b>
BD-700-1A10 airplanes	9381, 9432 through 9491 inclusive, 9496 through 9505 inclusive, 9507 through 9515 inclusive, 9518 through 9525 inclusive, 9527 through 9619 inclusive, 9622 through 9654 inclusive, 9657 through 9673 inclusive, 9677, 9680 through 9684 inclusive, 9686 through 9712 inclusive, 9716 through 9742 inclusive, 9744 through 9785 inclusive, 9788 through 9853, 9856 through 9867 inclusive, 9870, 9873 through 9878 inclusive.	700-35-6005, Revision 01, dated February 12, 2021
BD-700-1A10 airplanes	9861 and 9872	700-35-6501 Revision 01, dated February 12, 2021
BD-700-1A11 airplanes	9386, 9401 through 9613 inclusive, and 9618 through 9879 inclusive	700-35-5005, Revision 01, dated February 12, 2021

**(i) Parts Installation Prohibition**

As of the effective date of this AD, no person may install an oxygen hose assembly having a P/N in the O2C20T1 series on any airplane.

**(j) Credit for Previous Actions**

This paragraph provides credit for actions required by paragraph (g) of this AD, if those actions were performed before the effective date of this AD using the applicable service information specified in paragraphs (j)(1) through (5) of this AD.

- (1) Bombardier Service Bulletin 700-1A11-35-014, dated September 28, 2020.
- (2) Bombardier Service Bulletin 700-35-015, dated September 28, 2020.
- (3) Bombardier Service Bulletin 700-35-5005, dated September 28, 2020.
- (4) Bombardier Service Bulletin 700-35-6005, dated September 28, 2020.
- (5) Bombardier Service Bulletin 700-35-6501, dated September 28, 2020.

**(k) Other FAA AD Provisions**

The following provisions also apply to this AD:

(1) *Alternative Methods of Compliance (AMOCs)*: The Manager, New York ACO Branch, FAA, has the authority to approve AMOCs for this AD, if requested using the procedures found in 14 CFR 39.19. In accordance with 14 CFR 39.19, send your

request to your principal inspector or responsible Flight Standards Office, as appropriate. If sending information directly to the manager of the certification office, send it to ATTN: Program Manager, Continuing Operational Safety, FAA, New York ACO Branch, 1600 Stewart Avenue, Suite 410, Westbury, NY 11590; telephone 516-228-7300; fax 516-794-5531. Before using any approved AMOC, notify your appropriate principal inspector, or lacking a principal inspector, the manager of the responsible Flight Standards Office.

(2) *Contacting the Manufacturer*: For any requirement in this AD to obtain instructions from a manufacturer, the instructions must be accomplished using a method approved by the Manager, New York ACO Branch, FAA; or Transport Canada Civil Aviation (TCCA); or Bombardier, Inc.'s TCCA Design Approval Organization (DAO). If approved by the DAO, the approval must include the DAO-authorized signature.

**(l) Related Information**

(1) Refer to Mandatory Continuing Airworthiness Information (MCAI) TCCA AD CF-2021-17, dated April 28, 2021, for related information. This MCAI may be found in the AD docket on the internet at <https://www.regulations.gov> by searching for and locating Docket No. FAA-2022-0085.

(2) For more information about this AD, contact Elizabeth Dowling, Aerospace Engineer, Mechanical Systems and Administrative Services Section, FAA, New York ACO Branch, 1600 Stewart Avenue, Suite 410, Westbury, NY 11590; telephone 516-228-7300; fax 516-794-5531; email [9-avs-nyaco-cos@faa.gov](mailto:9-avs-nyaco-cos@faa.gov).

(3) For service information identified in this AD, contact Bombardier Business Aircraft Customer Response Center, 400 Côte-Vertu Road West, Dorval, Québec H4S 1Y9, Canada; telephone 514-855-2999; email [ac.yul@aero.bombardier.com](mailto:ac.yul@aero.bombardier.com); internet <https://www.bombardier.com>. You may view this service information at the FAA, Airworthiness Products Section, Operational Safety Branch, 2200 South 216th St., Des Moines, WA. For information on the availability of this material at the FAA, call 206-231-3195.

Issued on January 28, 2022.

**Lance T. Gant,**

*Director, Compliance & Airworthiness Division, Aircraft Certification Service.*

[FR Doc. 2022-02141 Filed 2-2-22; 8:45 am]

**BILLING CODE 4910-13-C**

**DEPARTMENT OF TRANSPORTATION****Federal Aviation Administration****14 CFR Part 39**

[Docket No. FAA-2022-0084; Project Identifier MCAI-2020-01312-A]

RIN 2120-AA64

**Airworthiness Directives; Pilatus Aircraft Ltd. Airplanes**

**AGENCY:** Federal Aviation Administration (FAA), DOT.

**ACTION:** Notice of proposed rulemaking (NPRM).

**SUMMARY:** The FAA proposes to adopt a new airworthiness directive (AD) for all Pilatus Aircraft Ltd. (Pilatus) Model PC-24 airplanes. This proposed AD was prompted by a failure of the dual ethernet communication channel on a dual-channel data concentration and processing unit, which triggered the opening of electronic circuit breakers that caused several unintended system activations. This proposed AD would require installing a software (SW) upgrade to the utility management system (UMS), as specified in a European Union Aviation Safety Agency (EASA) AD, which is proposed for incorporation by reference (IBR). The FAA is proposing this AD to address the unsafe condition on these products.

**DATES:** The FAA must receive comments on this proposed AD by March 21, 2022.

**ADDRESSES:** You may send comments, using the procedures found in 14 CFR 11.43 and 11.45, by any of the following methods:

- *Federal eRulemaking Portal:* Go to <https://www.regulations.gov>. Follow the instructions for submitting comments.
- *Fax:* (202) 493-2251.
- *Mail:* U.S. Department of Transportation, Docket Operations, M-30, West Building Ground Floor, Room W12-140, 1200 New Jersey Avenue SE, Washington, DC 20590.
- *Hand Delivery:* Deliver to Mail address above between 9 a.m. and 5 p.m., Monday through Friday, except Federal holidays.

For material that is proposed for IBR in this AD, contact EASA, Konrad-Adenauer-Ufer 3, 50668 Cologne, Germany; phone: +49 221 8999 000; email: [ADs@easa.europa.eu](mailto:ADs@easa.europa.eu); website: <https://www.easa.europa.eu>. For service information identified in this NPRM, contact Pilatus Aircraft Ltd., Customer Support General Aviation, CH-6371 Stans, Switzerland; phone: +41 848 24 7 365; email: [techsupport.ch@pilatus-aircraft.com](mailto:techsupport.ch@pilatus-aircraft.com); website: <https://www.pilatus-aircraft.com>. You may

view this material at the FAA, Airworthiness Products Section, Operational Safety Branch, 901 Locust, Kansas City, MO 64106. For information on the availability of this material at the FAA, call (817) 222-5110. The EASA material is also available at <https://www.regulations.gov> by searching for and locating Docket No. FAA-2022-0084.

**Examining the AD Docket**

You may examine the AD docket at <https://www.regulations.gov> by searching for and locating Docket No. FAA-2022-0084; or in person at Docket Operations between 9 a.m. and 5 p.m., Monday through Friday, except Federal holidays. The AD docket contains this NPRM, the EASA AD, any comments received, and other information. The street address for Docket Operations is listed above.

**FOR FURTHER INFORMATION CONTACT:**

Doug Rudolph, Aviation Safety Engineer, FAA, General Aviation & Rotorcraft Section, International Validation Branch, 901 Locust, Room 301, Kansas City, MO 64106; phone: (816) 329-4059; email: [doug.rudolph@faa.gov](mailto:doug.rudolph@faa.gov).

**SUPPLEMENTARY INFORMATION:****Comments Invited**

The FAA invites you to send any written relevant data, views, or arguments about this proposal. Send your comments to an address listed under **ADDRESSES**. Include "Docket No. FAA-2022-0084; Project Identifier MCAI-2020-01312-A" at the beginning of your comments. The most helpful comments reference a specific portion of the proposal, explain the reason for any recommended change, and include supporting data. The FAA will consider all comments received by the closing date and may amend this proposal because of those comments.

Except for Confidential Business Information (CBI) as described in the following paragraph, and other information as described in 14 CFR 11.35, the FAA will post all comments received, without change, to <https://www.regulations.gov>, including any personal information you provide. The agency will also post a report summarizing each substantive verbal contact received about this NPRM.

**Confidential Business Information**

CBI is commercial or financial information that is both customarily and actually treated as private by its owner. Under the Freedom of Information Act (FOIA) (5 U.S.C. 552), CBI is exempt from public disclosure. If you

comments responsive to this NPRM contain commercial or financial information that is customarily treated as private, that you actually treat as private, and that is relevant or responsive to this NPRM, it is important that you clearly designate the submitted comments as CBI. Please mark each page of your submission containing CBI as "PROPIN." The FAA will treat such marked submissions as confidential under the FOIA, and they will not be placed in the public docket of this NPRM. Submissions containing CBI should be sent to Doug Rudolph, Aviation Safety Engineer, FAA, General Aviation & Rotorcraft Section, International Validation Branch, 901 Locust, Room 301, Kansas City, MO 64106. Any commentary that the FAA receives that is not specifically designated as CBI will be placed in the public docket for this rulemaking.

**Background**

EASA, which is the Technical Agent for the Member States of the European Union, has issued EASA AD 2020-0200, dated September 21, 2020 (EASA AD 2020-0200), to correct an unsafe condition on Pilatus Model PC-24 airplanes, all serial numbers.

EASA AD 2020-0200 was prompted by a report that, during climb, a Model PC-24 airplane experienced a dual ethernet communication channel failure on a dual-channel data concentration and processing unit. The failure triggered the opening of electronic circuit breakers, which led to degradation of environmental control system functionalities, the deployment of all passenger oxygen masks, and the autopilot entering into emergency descent mode. According to EASA, various crew alerting system messages were displayed and the functionality of other systems (such as flaps, fuel indication, and the ice protection system) was significantly degraded.

The FAA is proposing this AD to address the failure of the dual ethernet communication channel on a dual-channel data concentration and processing unit. The unsafe condition, if not addressed, could result in an increased pilot workload and reduced control of the airplane.

**Related Service Information Under 14 CFR Part 51**

The FAA reviewed EASA AD 2020-0200, which specifies upgrading the UMS SW and prohibits installing an earlier version of the SW. This material is reasonably available because the interested parties have access to it through their normal course of business

or by the means identified in ADDRESSES.

**Other Related Service Information**

The FAA reviewed Pilatus PC-24 Service Bulletin No. 42-010, dated January 21, 2020. This service information contains procedures for upgrading the UMS SW to Build 7.3.

**FAA’s Determination**

These airplanes have been approved by EASA and are approved for operation in the United States. Pursuant to the FAA’s bilateral agreement with the European Union, EASA has notified the FAA about the unsafe condition described in the EASA AD. The FAA is issuing this NPRM after determining that the unsafe condition described previously is likely to exist or develop on other products of the same type design.

**Proposed AD Requirements in This NPRM**

This proposed AD would require accomplishing the actions specified in

EASA AD 2020-0200, described previously, as incorporated by reference, except as discussed under “Differences Between this Proposed AD and the EASA AD.”

**Explanation of Required Compliance Information**

In the FAA’s ongoing efforts to improve the efficiency of the AD process, the FAA initially worked with Airbus and EASA to develop a process to use some EASA ADs as the primary source of information for compliance with requirements for corresponding FAA ADs. The FAA has since coordinated with other manufacturers and civil aviation authorities to use this process. As a result, the FAA proposes to incorporate EASA AD 2020-0200 by reference in the FAA final rule. This proposed AD would require compliance with portions of EASA AD 2020-0200, except for any differences identified in the regulatory text of this proposed AD. Service information required by EASA AD 2020-0200 for compliance will be available at <https://www.regulations.gov>

by searching for and locating Docket No. FAA-2022-0084 after the FAA final rule is published.

**Differences Between This Proposed AD and the EASA AD**

Where EASA AD 2020-0200 requires compliance after its effective date, this proposed AD would require using the effective date of this AD. Where EASA AD 2020-0200 prohibits the installation of an affected part “from the effective date” of EASA AD 2020-0200, this proposed AD would require using “as of the effective date of this AD.” Although the service information referenced in EASA AD 2020-0200 specifies reporting information to the manufacturer, this proposed AD would not include that requirement.

**Costs of Compliance**

The FAA estimates that this AD, if adopted as proposed, would affect 42 airplanes of U.S. Registry.

The FAA estimates the following costs to comply with this proposed AD:

**ESTIMATED COSTS**

Action	Labor cost	Parts cost	Cost per airplane	Cost on U.S. operators
Install SW upgrade to UMS .....	8 work-hours × \$85 per hour = \$680 .....	\$5,000	\$5,680	\$238,560

The FAA has included all known costs in its cost estimate. According to the manufacturer, however, some of the costs of this proposed AD may be covered under warranty, thereby reducing the cost impact on affected operators.

**Authority for This Rulemaking**

Title 49 of the United States Code specifies the FAA’s authority to issue rules on aviation safety. Subtitle I, section 106, describes the authority of the FAA Administrator. Subtitle VII: Aviation Programs, describes in more detail the scope of the Agency’s authority.

The FAA is issuing this rulemaking under the authority described in Subtitle VII, Part A, Subpart III, Section 44701: General requirements. Under that section, Congress charges the FAA with promoting safe flight of civil aircraft in air commerce by prescribing regulations for practices, methods, and procedures the Administrator finds necessary for safety in air commerce. This regulation is within the scope of that authority because it addresses an unsafe condition that is likely to exist or develop on products identified in this rulemaking action.

**Regulatory Findings**

The FAA determined that this proposed AD would not have federalism implications under Executive Order 13132. This proposed AD would not have a substantial direct effect on the States, on the relationship between the national Government and the States, or on the distribution of power and responsibilities among the various levels of government.

For the reasons discussed above, I certify this proposed regulation:

- (1) Is not a “significant regulatory action” under Executive Order 12866,
- (2) Would not affect intrastate aviation in Alaska, and
- (3) Would not have a significant economic impact, positive or negative, on a substantial number of small entities under the criteria of the Regulatory Flexibility Act.

**List of Subjects in 14 CFR Part 39**

Air transportation, Aircraft, Aviation safety, Incorporation by reference, Safety.

**The Proposed Amendment**

Accordingly, under the authority delegated to me by the Administrator,

the FAA proposes to amend 14 CFR part 39 as follows:

**PART 39—AIRWORTHINESS DIRECTIVES**

- 1. The authority citation for part 39 continues to read as follows:

**Authority:** 49 U.S.C. 106(g), 40113, 44701.

**§ 39.13 [Amended]**

- 2. The FAA amends § 39.13 by adding the following new airworthiness directive:

**Pilatus Aircraft Ltd.:** Docket No. FAA-2022-0084; Project Identifier MCAI-2020-01312-A

**(a) Comments Due Date**

The FAA must receive comments on this airworthiness directive (AD) by March 21, 2022.

**(b) Affected ADs**

None.

**(c) Applicability**

This AD applies to Pilatus Aircraft Ltd. Model PC-24 airplanes, all serial numbers, certificated in any category.

**(d) Subject**

Joint Aircraft Service Component (JASC) Code: 2200, Auto Flight System; 2400, Electrical Power System; 3140, Central

Computers (EICAS); 3500, Oxygen System; and 4500, Central Maint, Computer.

**(e) Unsafe Condition**

This AD was prompted by a failure of the dual ethernet communication channel on a dual-channel data concentration and processing unit, which triggered the opening of electronic circuit breakers that caused several unintended system activations. The FAA is issuing this AD to prevent failure of the dual ethernet communication channel on a dual-channel data concentration and processing unit. The unsafe condition, if not addressed, could result in increased pilot workload and reduced control of the airplane.

**(f) Compliance**

Comply with this AD within the compliance times specified, unless already done.

**(g) Required Actions**

(1) For Group 1 airplanes as defined under the “Definitions” section in European Union Aviation Safety Agency AD 2020–0200, dated September 21, 2020 (EASA AD 2020–0200): Install the build 7.3 standard software upgrade to the utility management system software in accordance with paragraph 1 and the “Ref. Publications” section of EASA AD 2020–0200, except you are required to comply within 30 days after the effective date of this AD. After updating the software, do not install on that airplane utility management system software that is earlier than version 7.3.

(2) For Group 2 airplanes as defined under the “Definitions” section in EASA AD 2020–0200: As of the effective date of this AD, do not install utility management system software that is earlier than version 7.3 on any airplane.

**(h) Alternative Methods of Compliance (AMOCs)**

(1) The Manager, International Validation Branch, FAA, has the authority to approve AMOCs for this AD, if requested using the procedures found in 14 CFR 39.19. In accordance with 14 CFR 39.19, send your request to your principal inspector or local Flight Standards District Office, as appropriate. If sending information directly to the manager of the International Validation Branch, send it to the attention of the person identified in paragraph (i)(2) of this AD and email to: [9-AVS-AIR-730-AMOC@faa.gov](mailto:9-AVS-AIR-730-AMOC@faa.gov).

(2) Before using any approved AMOC, notify your appropriate principal inspector, or lacking a principal inspector, the manager of the local flight standards district office/certificate holding district office.

**(i) Related Information**

(1) For more information about EASA AD 2020–0200, contact EASA, Konrad-Adenauer-Ufer 3, 50668 Cologne, Germany; phone: +49 221 8999 000; email: [ADS@easa.europa.eu](mailto:ADS@easa.europa.eu). You may view this material at the FAA, Airworthiness Products Section, Operational Safety Branch, 901 Locust, Kansas City, MO 64106. For information on the availability of this material at the FAA, call (816) 329–4148. This material may be found in the AD docket at [https://](https://www.regulations.gov)

[www.regulations.gov](https://www.regulations.gov) by searching for and locating Docket No. FAA–2022–0084.

(2) For more information about this AD, contact Doug Rudolph, Aviation Safety Engineer, FAA, General Aviation & Rotorcraft Section, International Validation Branch, 901 Locust, Room 301, Kansas City, MO 64106; phone: (816) 329–4059; email: [doug.rudolph@faa.gov](mailto:doug.rudolph@faa.gov).

(3) For service information identified in this AD, Pilatus Aircraft Ltd., Customer Support General Aviation, CH–6371 Stans, Switzerland; phone: +41 848 24 7 365; email: [techsupport.ch@pilatus-aircraft.com](mailto:techsupport.ch@pilatus-aircraft.com); website: <https://www.pilatus-aircraft.com>. You may view this material at the FAA, Airworthiness Products Section, Operational Safety Branch, 901 Locust, Kansas City, MO 64106. For information on the availability of this material at the FAA, call (817) 222–5110.

Issued on January 27, 2022.

**Lance T. Gant,**

*Director, Compliance & Airworthiness Division, Aircraft Certification Service.*

[FR Doc. 2022–02130 Filed 2–2–22; 8:45 am]

**BILLING CODE 4910–13–P**

**DEPARTMENT OF TRANSPORTATION**

**Federal Aviation Administration**

**14 CFR Part 39**

**[Docket No. FAA–2022–0222; Project Identifier AD–2020–01264–A]**

**RIN 2120–AA64**

**Airworthiness Directives; Piper Aircraft, Inc., Airplanes**

**AGENCY:** Federal Aviation Administration (FAA), DOT.

**ACTION:** Notice of proposed rulemaking (NPRM).

**SUMMARY:** The FAA proposes to adopt a new airworthiness directive (AD) for certain Piper Aircraft, Inc., (Piper) Model PA–34–200 airplanes. This proposed AD was prompted by the determination that the life limit for alternate bolts that attach the drag link to the nose gear were not listed as airworthiness limitations. This proposed AD would require establishing a life limit for these bolts. The FAA is proposing this AD to address the unsafe condition on these products.

**DATES:** The FAA must receive comments on this proposed AD by March 21, 2022.

**ADDRESSES:** You may send comments, using the procedures found in 14 CFR 11.43 and 11.45, by any of the following methods:

- *Federal eRulemaking Portal:* Go to <https://www.regulations.gov>. Follow the instructions for submitting comments.
- *Fax:* (202) 493–2251.
- *Mail:* U.S. Department of Transportation, Docket Operations, M–

30, West Building Ground Floor, Room W12–140, 1200 New Jersey Avenue SE, Washington, DC 20590.

• *Hand Delivery:* Deliver to Mail address above between 9 a.m. and 5 p.m., Monday through Friday, except Federal holidays.

For service information identified in this NPRM, contact Piper Aircraft, Inc., 2926 Piper Drive, Vero Beach, FL 32960; phone: (772) 299–2141; website: <https://www.piper.com>. You may view this service information at the FAA, Airworthiness Products Section, Operational Safety Branch, 901 Locust, Kansas City, MO 64106. For information on the availability of this material at the FAA, call (817) 222–5110.

**Examining the AD Docket**

You may examine the AD docket at <https://www.regulations.gov> by searching for and locating Docket No. FAA–2022–0222; or in person at Docket Operations between 9 a.m. and 5 p.m., Monday through Friday, except Federal holidays. The AD docket contains this NPRM, any comments received, and other information. The street address for Docket Operations is listed above.

**FOR FURTHER INFORMATION CONTACT:** John Marshall, Aviation Safety Engineer, Atlanta ACO Branch, FAA, 1701 Columbia Avenue, College Park, GA 30337; phone: (404) 474–5524; email: [john.r.marshall@faa.gov](mailto:john.r.marshall@faa.gov).

**SUPPLEMENTARY INFORMATION:**

**Comments Invited**

The FAA invites you to send any written relevant data, views, or arguments about this proposal. Send your comments to an address listed under **ADDRESSES**. Include “Docket No. FAA–2022–0222; Project Identifier AD–2020–01264–A” at the beginning of your comments. The most helpful comments reference a specific portion of the proposal, explain the reason for any recommended change, and include supporting data. The FAA will consider all comments received by the closing date and may amend this proposal because of those comments.

Except for Confidential Business Information (CBI) as described in the following paragraph, and other information as described in 14 CFR 11.35, the FAA will post all comments received, without change, to <https://www.regulations.gov>, including any personal information you provide. The agency will also post a report summarizing each substantive verbal contact received about this NPRM.

**Confidential Business Information**

CBI is commercial or financial information that is both customarily and



actually treated as private by its owner. Under the Freedom of Information Act (FOIA) (5 U.S.C. 552), CBI is exempt from public disclosure. If your comments responsive to this NPRM contain commercial or financial information that is customarily treated as private, that you actually treat as private, and that is relevant or responsive to this NPRM, it is important that you clearly designate the submitted comments as CBI. Please mark each page of your submission containing CBI as "PROPIN." The FAA will treat such marked submissions as confidential under the FOIA, and they will not be placed in the public docket of this NPRM. Submissions containing CBI should be sent to John Marshall, Aviation Safety Engineer, Atlanta ACO Branch, FAA, 1701 Columbia Avenue, College Park, GA 30337. Any commentary that the FAA receives that is not specifically designated as CBI will be placed in the public docket for this rulemaking.

**Background**

Piper notified the FAA that prior revisions of the ALS for certain Piper Model PA-34-200 airplanes did not contain a life limit for bolt part number (P/N) 693-215 (standard P/N NAS6207-50D). Bolt P/N 693-215 (NAS6207-50D) is an alternate part for P/N 400-274 (standard P/N AN7-35). These bolts

attach the drag link to the nose gear trunnion on Piper Model PA-34-200 airplanes. Piper did not include an ALS revision for the P/N 693-215 (standard P/N NAS6207-50D) bolt to establish the same life limit as the P/N 400-274 (AN7-35).

If bolt P/N 693-215 (standard P/N NAS6207-50D) that attaches the drag link to the nose gear trunnion remains in service beyond its fatigue life, failure of the nose landing gear could occur, which could result in loss of airplane control during take-off, landing, or taxi operations.

**FAA's Determination**

The FAA is issuing this NPRM after determining that the unsafe condition described previously is likely to exist or develop on other products of the same type design.

**Related Service Information**

The FAA reviewed Piper Seneca Service Manual, Airworthiness Limitations, 753-817, page 1-1, dated November 30, 2019. This service information specifies the life limits of the P/N 693-215 (standard P/N NAS6207-50D) bolt that attaches the drag link to the nose gear trunnion.

**ADs Mandating Airworthiness Limitations**

The FAA has previously mandated airworthiness limitations by issuing

ADs that require revising the ALS of the existing maintenance manual or instructions for continued airworthiness to incorporate new or revised inspections and life limits. This AD, however, requires incorporating new or revised inspections and life limits into the maintenance records required by 14 CFR 91.417(a)(2) or 135.439(a)(2) for your airplane. The FAA does not intend this as a substantive change. Requiring incorporation of the new ALS requirements into the maintenance records, rather than requiring individual repetitive inspections and replacements, allows operators to record AD compliance once after updating the maintenance records, rather than recording compliance after every inspection and part replacement.

**Proposed AD Requirements in This NPRM**

This proposed AD would require establishing a 500-hour life limit for bolt P/N 693-215 and P/N NAS6207-50D.

**Costs of Compliance**

The FAA estimates that this AD, if adopted as proposed, would affect 187 airplanes of U.S. registry.

The FAA estimates the following costs to comply with this proposed AD:

**ESTIMATED COSTS**

Action	Labor cost	Parts cost	Cost per airplane	Cost on U.S. operators
Revise the Airworthiness Limitations .....	1 work-hour × \$85 per hour = \$85 .....	Not Applicable .....	\$85	\$15,895

**Authority for This Rulemaking**

Title 49 of the United States Code specifies the FAA's authority to issue rules on aviation safety. Subtitle I, section 106, describes the authority of the FAA Administrator. Subtitle VII: Aviation Programs, describes in more detail the scope of the Agency's authority.

The FAA is issuing this rulemaking under the authority described in Subtitle VII, Part A, Subpart III, Section 44701: General requirements. Under that section, Congress charges the FAA with promoting safe flight of civil aircraft in air commerce by prescribing regulations for practices, methods, and procedures the Administrator finds necessary for safety in air commerce. This regulation is within the scope of that authority because it addresses an unsafe condition that is likely to exist or

develop on products identified in this rulemaking action.

**Regulatory Findings**

The FAA determined that this proposed AD would not have federalism implications under Executive Order 13132. This proposed AD would not have a substantial direct effect on the States, on the relationship between the national government and the States, or on the distribution of power and responsibilities among the various levels of government.

For the reasons discussed above, I certify this proposed regulation:

- (1) Is not a "significant regulatory action" under Executive Order 12866,
- (2) Would not affect intrastate aviation in Alaska, and
- (3) Would not have a significant economic impact, positive or negative, on a substantial number of small entities

under the criteria of the Regulatory Flexibility Act.

**List of Subjects in 14 CFR Part 39**

Air transportation, Aircraft, Aviation safety, Incorporation by reference, Safety.

**The Proposed Amendment**

Accordingly, under the authority delegated to me by the Administrator, the FAA proposes to amend 14 CFR part 39 as follows:

**PART 39—AIRWORTHINESS DIRECTIVES**

- 1. The authority citation for part 39 continues to read as follows:

**Authority:** 49 U.S.C. 106(g), 40113, 44701.

**§ 39.13 [Amended]**

■ 2. The FAA amends § 39.13 by adding the following new airworthiness directive:

**Piper Aircraft, Inc.:** Docket No. FAA-2022-0222; Project Identifier AD-2020-01264-A.

**(a) Comments Due Date**

The FAA must receive comments on this airworthiness directive (AD) by March 21, 2022.

**(b) Affected ADs**

None.

**(c) Applicability**

This AD applies to Piper Aircraft, Inc., Model PA-34-200 airplanes, serial numbers 34-7250001 through 34-7450220, certificated in any category.

**(d) Subject**

Joint Aircraft System Component (JASC) Code 3220, Nose/Tail Landing Gear.

**(e) Unsafe Condition**

This AD was prompted by the determination that the life limit for alternate bolts that attach the drag link to the nose gear were not included as airworthiness limitations. The FAA is issuing this AD to establish a life limit on bolt part numbers 693-215 and NAS6207-50D that attach the drag link to the nose gear trunnion. The unsafe condition, if not addressed, could result in failure of the nose landing gear and lead to loss of airplane control during take-off, landing, or taxi operations.

**(f) Compliance**

Comply with this AD within the compliance times specified, unless already done.

**(g) Actions**

(1) Within 90 days after the effective date of this AD, incorporate into the maintenance records required by 14 CFR 91.417(a)(2) or 135.439(a)(2) for your airplane a life limit of 500 hours for bolt part numbers 693-215 and NAS6207-50D.

**Note to paragraph (g)(1):** Piper Seneca Service Manual, Airworthiness Limitations, 753-817, page 1-1, dated November 30, 2019, contains the life limit in paragraph (g)(1) of this AD.

(2) Thereafter, except as provided in paragraph (h)(1) of this AD, no alternative replacement times may be approved for these bolts.

**(h) Alternative Methods of Compliance (AMOCs)**

(1) The Manager, Atlanta ACO Branch, FAA, has the authority to approve AMOCs for this AD, if requested using the procedures found in 14 CFR 39.19. In accordance with 14 CFR 39.19, send your request to your principal inspector or local Flight Standards District Office, as appropriate. If sending information directly to the manager of the certification office, send it to the attention of the person identified in paragraph (i)(1) of this AD.

(2) Before using any approved AMOC, notify your appropriate principal inspector,

or lacking a principal inspector, the manager of the local flight standards district office/certificate holding district office.

**(i) Related Information**

(1) For more information about this AD, contact John Marshall, Aviation Safety Engineer, Atlanta ACO Branch, FAA, 1701 Columbia Avenue, College Park, GA 30337; phone: (404) 474-5524; email: [john.r.marshall@faa.gov](mailto:john.r.marshall@faa.gov).

(2) For service information identified in this AD, contact Piper Aircraft, Inc., 2926 Piper Drive, Vero Beach, FL 32960; phone: (772) 299-2141; website: <https://www.piper.com>. You may view this referenced service information at the FAA, Airworthiness Products Section, Operational Safety Branch, 901 Locust, Kansas City, MO 64106. For information on the availability of this material at the FAA, call (817) 222-5110.

Issued on January 27, 2022.

**Lance T. Gant,**

Director, Compliance & Airworthiness Division, Aircraft Certification Service.

[FR Doc. 2022-02072 Filed 2-2-22; 8:45 am]

**BILLING CODE 4910-13-P**

**DEPARTMENT OF TRANSPORTATION****Federal Aviation Administration****14 CFR Part 39**

**[Docket No. FAA-2022-0024; Project Identifier MCAI-2021-00994-R]**

**RIN 2120-AA64**

**Airworthiness Directives; Leonardo S.p.a. Helicopters**

**AGENCY:** Federal Aviation Administration (FAA), DOT.

**ACTION:** Notice of proposed rulemaking (NPRM).

**SUMMARY:** The FAA proposes to supersede Airworthiness Directive (AD) 2021-17-18, which applies to all Leonardo S.p.a. Model A109C, A109K2, A109E, A109S, and AW109SP helicopters. AD 2021-17-18 requires an inspection of certain tail rotor (TR) sleeve assemblies for discrepancies, an inspection of certain TR shaft assemblies for discrepancies, a repetitive measurement of the position of the bushing of the TR sleeve assembly in relation to the pitch change slider assembly, and corrective actions if necessary. Since the FAA issued AD 2021-17-18, the FAA has determined that it is necessary to require repetitive inspections of certain TR sleeve assemblies and corrective actions. This proposed AD would retain the requirements of AD 2021-17-18; and would also require repetitive inspections of the TR sleeve assemblies, and corrective actions if necessary, as

specified in a European Union Aviation Safety Agency (EASA) AD, which is proposed for incorporation by reference (IBR). The FAA is proposing this AD to address the unsafe condition on these products.

**DATES:** The FAA must receive comments on this proposed AD by March 21, 2022.

**ADDRESSES:** You may send comments, using the procedures found in 14 CFR 11.43 and 11.45, by any of the following methods:

- **Federal eRulemaking Portal:** Go to <https://www.regulations.gov>. Follow the instructions for submitting comments.

- **Fax:** 202-493-2251.

- **Mail:** U.S. Department of Transportation, Docket Operations, M-30, West Building Ground Floor, Room W12-140, 1200 New Jersey Avenue SE, Washington, DC 20590.

- **Hand Delivery:** Deliver to Mail address above between 9 a.m. and 5 p.m., Monday through Friday, except Federal holidays.

For material that is proposed for IBR in this AD, contact the EASA, Konrad-Adenauer-Ufer 3, 50668 Cologne, Germany; phone: +49 221 8999 000; email: [ADs@easa.europa.eu](mailto:ADs@easa.europa.eu); internet: [www.easa.europa.eu](http://www.easa.europa.eu). You may find this IBR material on the EASA website at <https://ad.easa.europa.eu>. You may view this material at the FAA, Office of the Regional Counsel, Southwest Region, 10101 Hillwood Pkwy., Room 6N-321, Fort Worth, TX 76177. For information on the availability of this material at the FAA, call 817-222-5110. It is also available in the AD docket at <https://www.regulations.gov> by searching for and locating Docket No. FAA-2022-0024.

**Examining the AD Docket**

You may examine the AD docket at <https://www.regulations.gov> by searching for and locating Docket No. FAA-2022-0024; or in person at Docket Operations between 9 a.m. and 5 p.m., Monday through Friday, except Federal holidays. The AD docket contains this NPRM, any comments received, and other information. The street address for Docket Operations is listed above. Comments will be available in the AD docket shortly after receipt.

**FOR FURTHER INFORMATION CONTACT:** Andrea Jimenez, Aerospace Engineer, COS Program Management Section, Operational Safety Branch, FAA, 1600 Stewart Ave., Suite 410, Westbury, NY 11590; phone: (516) 228-7330; email: [andrea.jimenez@faa.gov](mailto:andrea.jimenez@faa.gov).

**SUPPLEMENTARY INFORMATION:**

### Comments Invited

The FAA invites you to send any written relevant data, views, or arguments about this proposal. Send your comments to an address listed under **ADDRESSES**. Include “Docket No. FAA–2022–0024; Project Identifier MCAI–2021–00994–R” at the beginning of your comments. The most helpful comments reference a specific portion of the proposal, explain the reason for any recommended change, and include supporting data. The FAA will consider all comments received by the closing date and may amend this proposal because of those comments.

Except for Confidential Business Information (CBI) as described in the following paragraph, and other information as described in 14 CFR 11.35, the FAA will post all comments received, without change, to <https://www.regulations.gov>, including any personal information you provide. The agency will also post a report summarizing each substantive verbal contact received about this proposal.

### Confidential Business Information

CBI is commercial or financial information that is both customarily and actually treated as private by its owner. Under the Freedom of Information Act (FOIA) (5 U.S.C. 552), CBI is exempt from public disclosure. If your comments responsive to this NPRM contain commercial or financial information that is customarily treated as private, that you actually treat as private, and that is relevant or responsive to this NPRM, it is important that you clearly designate the submitted comments as CBI. Please mark each page of your submission containing CBI as “PROPIN.” The FAA will treat such marked submissions as confidential under the FOIA, and they will not be placed in the public docket of this NPRM. Submissions containing CBI should be sent to Andrea Jimenez, Aerospace Engineer, COS Program Management Section, Operational Safety Branch, FAA, 1600 Stewart Ave., Suite 410, Westbury, NY 11590; phone: (516) 228–7330; email: [andrea.jimenez@faa.gov](mailto:andrea.jimenez@faa.gov). Any commentary that the FAA receives that is not specifically designated as CBI will be placed in the public docket for this rulemaking.

### Background

The FAA issued AD 2021–17–18, Amendment 39–21701 (86 FR 46766, August 20, 2021) (AD 2021–17–18), which applies to all Leonardo S.p.a. Model A109C, A109K2, A109E, A109S, and AW109SP helicopters. AD 2021–17–18 requires an inspection of certain

TR sleeve assemblies for discrepancies, an inspection of certain TR shaft assemblies for discrepancies, a repetitive measurement of the position of the bushing of the TR sleeve assembly in relation to the pitch change slider assembly, and corrective actions if necessary. The FAA issued AD 2021–17–18 to address cracking on the TR mast, which could lead to failure of the TR mast, with consequent loss of control of the helicopter.

### Actions Since AD 2021–17–18 Was Issued

The preamble to AD 2021–17–18 explains that the FAA was considering further rulemaking to address the actions specified in paragraphs (5) and (9) of EASA AD 2021–0144, dated June 17, 2021 (EASA AD 2021–0144). The FAA has now determined that further rulemaking is indeed necessary, and this proposed AD follows from that determination.

The EASA, which is the Technical Agent for the Member States of the European Union, has issued EASA AD 2021–0144 (also referred to as the Mandatory Continuing Airworthiness Information, or the MCAI), to correct an unsafe condition for all Leonardo S.p.a. (formerly Finmeccanica S.p.A., AgustaWestland S.p.A., Agusta S.p.A.) Model A109C, A109K2, A109E, A109S, and AW109SP helicopters.

This proposed AD was prompted by a determination that additional actions are required to address the unsafe condition. This proposed AD was also prompted by a report of a crack on the TR mast. The FAA is proposing this AD to address cracking on the TR mast, which could lead to failure of the TR mast, with consequent loss of control of the helicopter. See the MCAI for additional background information.

### Related Service Information Under 1 CFR Part 51

This proposed AD would require EASA AD 2021–0144, which the Director of the Federal Register approved for incorporation by reference as of September 7, 2021 (86 FR 46766, August 20, 2021). This material is reasonably available because the interested parties have access to it through their normal course of business or by the means identified in the **ADDRESSES** section.

### FAA’s Determination and Requirements of This Proposed AD

These products have been approved by the aviation authority of another country, and are approved for operation in the United States. Pursuant to the bilateral agreement with the State of

Design Authority, the FAA has been notified of the unsafe condition described in the MCAI referenced above. The FAA is proposing this AD after evaluating all the relevant information and determining the unsafe condition described previously is likely to exist or develop in other products of the same type design.

### Proposed AD Requirements

This proposed AD would require accomplishing the actions specified in EASA AD 2021–0144 described previously, as incorporated by reference, except for any differences identified as exceptions in the regulatory text of this AD and except as discussed under “Difference Between this Proposed AD and the MCAI.”

### Explanation of Required Compliance Information

In the FAA’s ongoing efforts to improve the efficiency of the AD process, the FAA initially worked with Airbus and EASA to develop a process to use certain EASA ADs as the primary source of information for compliance with requirements for corresponding FAA ADs. The FAA has since coordinated with other manufacturers and civil aviation authorities to use this process. As a result, EASA AD 2021–0144 will be incorporated by reference in the FAA final rule. This proposed AD would, therefore, require compliance with EASA AD 2021–0144 in its entirety, through that incorporation, except for any differences identified as exceptions in the regulatory text of this proposed AD. Using common terms that are the same as the heading of a particular section in the EASA AD does not mean that operators need comply only with that section. For example, where the AD requirement refers to “all required actions and compliance times,” compliance with this AD requirement is not limited to the section titled “Required Action(s) and Compliance Time(s)” in the EASA AD. Service information specified in EASA AD 2021–0144 that is required for compliance with EASA AD 2021–0144 will be available on the internet at <https://www.regulations.gov> by searching for and locating Docket No. FAA–2022–0024 after the FAA final rule is published.

### Difference Between This Proposed AD and the MCAI

Paragraph (1) of EASA AD 2021–0144 specifies the inspection must be done within 25 flight hours or 3 months, whichever occurs first. However, this AD requires the inspection to be done within 25 hours time-in-service after

September 7, 2021 (the effective date of AD 2021–17–18).

**Interim Action**

The FAA considers this proposed AD interim action. The inspection reports that are required by this proposed AD

will enable the manufacturer to obtain better insight into the nature, cause, and extent of the cracking, and eventually to develop final action to address the unsafe condition. Once final action has been identified, the FAA might consider further rulemaking.

**Costs of Compliance**

The FAA estimates that this proposed AD affects 133 helicopters of U.S. registry. The FAA estimates the following costs to comply with this proposed AD:

**ESTIMATED COSTS FOR REQUIRED ACTIONS**

Action	Labor cost	Parts cost	Cost per product	Cost on U.S. operators
Retained Inspections/from AD 2021–17–18.	Up to 6 work-hours × \$85 per hour = \$510 per inspection/measurement cycle.	\$0	Up to \$510 per inspection/measurement cycle.	Up to \$67,830 per inspection/measurement cycle.
New proposed Repetitive Inspections	Up to 1 work-hour × \$85 per hour = \$85 per inspection cycle.	0	Up to \$85 per inspection cycle.	Up to \$11,305 per inspection cycle.

The FAA estimates the following costs to do any necessary on-condition actions (replacements, repairs, and

reporting) that would be required based on the results of any required actions. The FAA has no way of determining the

number of helicopters that might need these on-condition actions:

**ESTIMATED COSTS OF ON-CONDITION ACTIONS \***

Action	Labor cost	Parts cost	Cost per product
Retained Replacements .....	19 work-hours × \$85 per hour = \$1,615 .....	\$88,760	Up to \$90,375.
Retained Reporting .....	1 work-hour × \$85 per hour = \$85 .....	0	\$85.

\* The FAA has received no definitive data on which to base the cost estimates for the on-condition repairs specified in this proposed AD. However, the cost for restoring solid film lubricant is considered to be negligible.

According to the manufacturer, some or all of the costs of this proposed AD may be covered under warranty, thereby reducing the cost impact on affected operators. The FAA does not control warranty coverage for affected operators. As a result, the FAA has included all known costs in the cost estimate.

**Paperwork Reduction Act**

A federal agency may not conduct or sponsor, and a person is not required to respond to, nor shall a person be subject to penalty for failure to comply with a collection of information subject to the requirements of the Paperwork Reduction Act unless that collection of information displays a current valid OMB control number. The control number for the collection of information required by this proposed AD is 2120–0056. The paperwork cost associated with this proposed AD has been detailed in the Costs of Compliance section of this document and includes time for reviewing instructions, as well as completing and reviewing the collection of information. Therefore, all reporting associated with this proposed AD is mandatory. Comments concerning the accuracy of this burden and suggestions for reducing the burden should be directed to Information Collection Clearance Officer, Federal Aviation Administration, 10101

Hillwood Pkwy., Fort Worth, TX 76177–1524.

**Authority for This Rulemaking**

Title 49 of the United States Code specifies the FAA’s authority to issue rules on aviation safety. Subtitle I, section 106, describes the authority of the FAA Administrator. Subtitle VII: Aviation Programs, describes in more detail the scope of the Agency’s authority.

The FAA is issuing this rulemaking under the authority described in Subtitle VII, Part A, Subpart III, Section 44701: General requirements. Under that section, Congress charges the FAA with promoting safe flight of civil aircraft in air commerce by prescribing regulations for practices, methods, and procedures the Administrator finds necessary for safety in air commerce. This regulation is within the scope of that authority because it addresses an unsafe condition that is likely to exist or develop on products identified in this rulemaking action.

**Regulatory Findings**

The FAA determined that this proposed AD would not have federalism implications under Executive Order 13132. This proposed AD would not have a substantial direct effect on the States, on the relationship between the national Government and the States, or

on the distribution of power and responsibilities among the various levels of government.

For the reasons discussed above, I certify this proposed regulation:

- (1) Is not a “significant regulatory action” under Executive Order 12866,
- (2) Would not affect intrastate aviation in Alaska, and
- (3) Would not have a significant economic impact, positive or negative, on a substantial number of small entities under the criteria of the Regulatory Flexibility Act.

**List of Subjects in 14 CFR Part 39**

Air transportation, Aircraft, Aviation safety, Incorporation by reference, Safety.

**The Proposed Amendment**

Accordingly, under the authority delegated to me by the Administrator, the FAA proposes to amend 14 CFR part 39 as follows:

**PART 39—AIRWORTHINESS DIRECTIVES**

- 1. The authority citation for part 39 continues to read as follows:

**Authority:** 49 U.S.C. 106(g), 40113, 44701.

**§ 39.13 [Amended]**

- 2. The FAA amends § 39.13 by:
  - a. Removing Airworthiness Directive (AD) 2021–17–18, Amendment 39–

21701 (86 FR 46766, August 20, 2021); and

■ **b. Adding the following new AD:**

**Leonardo S.p.a.:** Docket No. FAA–2022–0024; Project Identifier MCAI–2021–00994–R.

**(a) Comments Due Date**

The FAA must receive comments by March 21, 2022.

**(b) Affected Airworthiness Directives (ADs)**

This AD replaces AD 2021–17–18, Amendment 39–21701 (86 FR 46766, August 20, 2021) (AD 2021–17–18).

**(c) Applicability**

This AD applies to all Leonardo S.p.a. Model A109C, A109K2, A109E, A109S, and AW109SP helicopters, certificated in any category.

**(d) Subject**

Joint Aircraft System Component (JASC) Code 6400, Tail Rotor System.

**(e) Unsafe Condition**

This AD was prompted by a report of a crack on the tail rotor (TR) mast. The FAA is issuing this AD to address cracking on the TR mast, which could lead to failure of the TR mast, with consequent loss of control of the helicopter.

**(f) Compliance**

Comply with this AD within the compliance times specified, unless already done.

**(g) Requirements**

Except as specified in paragraph (h) of this AD: Comply with all required actions and compliance times specified in, and in accordance with, European Union Aviation Safety Agency (EASA) AD 2021–0144, dated June 17, 2021 (EASA AD 2021–0144).

**(h) Exceptions to EASA AD 2021–0144**

(1) Where EASA AD 2021–0144 refers to its effective date, this AD requires using September 7, 2021 (the effective date of AD 2021–17–18).

(2) The “Remarks” section of EASA AD 2021–0144 does not apply to this AD.

(3) Where EASA AD 2021–0144 refers to flight hours (FH), this AD requires using hours time-in-service.

(4) Where paragraph (1) of EASA AD 2021–0144 specifies a compliance time of 25 FH or 3 months, whichever occurs first, this AD requires compliance within 25 hours time-in-service after September 7, 2021 (the effective date of AD 2021–17–18).

(5) Where Note 1 of EASA AD 2021–0144 specifies a tolerance of 30 FH, this AD does not allow a tolerance.

(6) The initial compliance time for the inspection specified in paragraph (5) of EASA AD 2021–0144 is at the compliance time specified in paragraph (5) of EASA AD 2021–0144, or within 30 days after the effective date of this AD, whichever occurs later.

(7) Where paragraph (6) of EASA AD 2021–0144 states the term “discrepancies,” for the purposes of this AD discrepancies include

dents, corrosion, elongation, scratches, wear, excessive wear (web visible), fretting, or stepping.

(8) Where paragraph (7) of EASA AD 2021–0144 states the term “discrepancies,” for the purposes of this AD discrepancies include abnormal wear condition, corrosion, fretting, crack, or damage (including dents, elongation, scratches, or stepping).

(9) Where EASA AD 2021–0144 defines “serviceable part,” and that definition specifies instructions that are “approved under Leonardo Design Organization Approval (DOA) or by EASA,” for this AD, the repair must be accomplished using a method approved by the Manager, General Aviation and Rotorcraft Section, International Validation Branch, FAA; or EASA; or Leonardo S.p.a.’s EASA DOA. If approved by the DOA, the approval must include the DOA-authorized signature.

(10) Where Note 2 and paragraph (7) of EASA AD 2021–0144 specify instructions that are “approved under Leonardo DOA or by EASA,” for this AD, the repair must be accomplished using a method approved by the Manager, General Aviation and Rotorcraft Section, International Validation Branch, FAA; or EASA; or Leonardo S.p.a.’s EASA DOA. If approved by the DOA, the approval must include the DOA-authorized signature.

(11) Where the service information referenced in EASA AD 2021–0144 specifies to contact the manufacturer for corrective action, this AD requires the repair to be done in accordance with a method approved by the Manager, General Aviation and Rotorcraft Section, International Validation Branch, FAA; or EASA; or Leonardo S.p.a.’s EASA DOA. If approved by the DOA, the approval must include the DOA-authorized signature.

(12) Where the service information referenced in EASA AD 2021–0144 specifies to discard a certain part, this AD requires removing that part from service.

**(i) Special Flight Permit**

Special flight permits may be issued in accordance with 14 CFR 21.197 and 21.199 to operate the helicopter to a location where the actions of this AD can be performed, provided no passengers are onboard.

**(j) Alternative Methods of Compliance (AMOCs)**

(1) The Manager, International Validation Branch, FAA, has the authority to approve AMOCs for this AD, if requested using the procedures found in 14 CFR 39.19. In accordance with 14 CFR 39.19, send your request to your principal inspector or local Flight Standards District Office, as appropriate. If sending information directly to the manager of the International Validation Branch, send it to the attention of the person identified in paragraph (k)(2) of this AD. Information may be emailed to: [9-AVS-AIR-730-AMOC@faa.gov](mailto:9-AVS-AIR-730-AMOC@faa.gov).

(2) Before using any approved AMOC, notify your appropriate principal inspector, or lacking a principal inspector, the manager of the local flight standards district office/certificate holding district office.

**(k) Related Information**

(1) For EASA AD 2021–0144, contact the EASA, Konrad-Adenauer-Ufer 3, 50668

Cologne, Germany; phone: +49 221 8999 000; email: [ADs@easa.europa.eu](mailto:ADs@easa.europa.eu); internet: [www.easa.europa.eu](http://www.easa.europa.eu). You may find this EASA AD on the EASA website at <https://ad.easa.europa.eu>. You may view this material at the FAA, Office of the Regional Counsel, Southwest Region, 10101 Hillwood Pkwy., Room 6N–321, Fort Worth, TX 76177. For information on the availability of this material at the FAA, call 817–222–5110. This material may be found in the AD docket on the internet at <https://www.regulations.gov> by searching for and locating Docket No. FAA–2022–0024.

(2) For more information about this AD, contact Andrea Jimenez, Aerospace Engineer, COS Program Management Section, Operational Safety Branch, FAA, 1600 Stewart Ave., Suite 410, Westbury, NY 11590; phone: (516) 228–7330; email: [andrea.jimenez@faa.gov](mailto:andrea.jimenez@faa.gov).

Issued on January 27, 2022.

**Lance T. Gant,**

*Director, Compliance & Airworthiness Division, Aircraft Certification Service.*

[FR Doc. 2022–02073 Filed 2–2–22; 8:45 am]

**BILLING CODE 4910–13–P**

---

**RAILROAD RETIREMENT BOARD**

**20 CFR Part 220**

**RIN 3220–AB77**

**Consultative Examinations**

**AGENCY:** Railroad Retirement Board.

**ACTION:** Proposed rule.

**SUMMARY:** The Railroad Retirement Board proposes to amend its regulations concerning consultative examinations used in adjudication of claims for disability annuities. The amendment will permit psychological and psychiatric consultative examinations to be conducted through the use of video teleconferencing technology. The amendment will allow the remote conduct of examinations where physical contact is not required and will facilitate medical evaluations when physical proximity is not feasible.

**DATES:** Submit comments on or before April 4, 2022.

**ADDRESSES:** You may send comments, identified by RIN number, by any of the following methods:

*Federal eRulemaking Portal:* <http://www.regulations.gov>. Follow the instructions for sending comments.

*Email:* [SecretarytotheBoard@RRB.gov](mailto:SecretarytotheBoard@RRB.gov). Include RIN 3220–AB77 in the subject line of the message.

*Mail:* Secretary to the Board, Railroad Retirement Board, 844 N Rush St., Chicago, IL 60611–1275.

**FOR FURTHER INFORMATION CONTACT:** Marguerite P. Dadabo, (312) 751–4945,

TTD (312) 751-4701,  
Marguerite.Dadabo@rrb.gov.

**SUPPLEMENTARY INFORMATION:** The Railroad Retirement Board (Board) proposes to amend its disability regulations to allow video teleconferencing technology (VTT) to be used to conduct a psychological or a psychiatric consultative examination in a case where such technology permits proper evaluation of a claimant. A VTT consultative examination is an examination conducted through a telecommunications system that allows the examining physician or psychologist and the claimant to see and hear each other for the purpose of communication in real time. A VTT consultative examination must comply with all requirements for consultative examinations in subpart G of Part 220 of the Board's regulations, 20 CFR part 220, subpart G. In addition, the following requirements must be followed if a VTT consultative examination is used. The examining physician or psychologist must be currently licensed in the state in which the provider practices.

The examining physician or psychologist must have the training and experience to perform the type of examination requested. The examining physician or psychologist must have access to VTT, and the claimant must live in the same state in which the provider practices. The claimant shall have the right to refuse a VTT consultative examination without penalty.

#### Regulatory Requirements

*Executive Order 12866, as  
Supplemented by Executive Order  
13563*

We consulted with the Office of Management and Budget (OMB) and determined that this proposed rule does not meet the criteria for a significant regulatory action under Executive Order 12866, as supplemented by Executive Order 13563.

*Executive Order 13132 (Federalism)*

This proposed rule will not have substantial direct effects on the States, on the relationship between the National Government and the States, or on the distribution of power and responsibilities among the various levels of government. Therefore, in accordance with section 6 of Executive Order 13132, the Board believes that this proposed rule will not have sufficient federalism implications to warrant the preparation of a federalism summary impact statement.

#### Regulatory Flexibility Act

We certify that this proposed rule would not have a significant economic impact on a substantial number of small entities because the proposed rule affects individuals only. Therefore, a regulatory flexibility analysis is not required under the Regulatory Flexibility Act, as amended.

#### Unfunded Mandates Reform Act of 1995

This proposed rule will not result in the expenditure by State, local, and Tribal governments, in the aggregate, or by the private sector, of \$100 million or more in any one year, and it will not significantly or uniquely affect small governments. Therefore, no actions are deemed necessary under the provisions of the Unfunded Mandates Reform Act of 1995.

#### Paperwork Reduction Act

This proposed rule does not create any new or affect any existing collections and, therefore, does not require OMB approval under the Paperwork Reduction Act.

#### List of Subjects in 20 CFR Part 220

Disability benefits, railroad employees, railroad retirement.

For the reasons discussed in the Preamble, the Railroad Retirement Board proposes to amend 20 CFR part 220 as follows:

#### PART 220—DETERMINING DISABILITY

■ 1. The authority citation for part 220 continues to read as follows:

**Authority:** 45 U.S.C. 231a; 45 U.S.C. 231f.

■ 2. Amend § 220.57 by adding paragraph (c) to read as follows:

#### § 220.57 Types of purchased examinations and selection of sources.

\* \* \* \* \*

(c) *Use of Video Teleconferencing Technology.* Video teleconferencing technology (VTT) may be used for a psychological or a psychiatric consultative examination provided that the following requirements are met:

(1) The examining physician or psychologist is currently state-licensed in the state in which the provider practices;

(2) The examining physician or psychologist has the training and experience to perform the type of examination requested;

(3) The examining physician or psychologist has access to video teleconferencing technology;

(4) The examining physician or psychologist is permitted to perform the exam in accordance with state licensing laws and regulations;

(5) The protocol for the examination does not require physical contact;  
(6) The claimant has the right to refuse a VTT examination without penalty; and

(7) The VTT examination complies with all requirements in this Subpart governing consultative examinations.

Dated: January 27, 2022.

For the Board

**Stephanie Hillyard,**

*Secretary to the Board.*

[FR Doc. 2022-02065 Filed 2-2-22; 8:45 am]

**BILLING CODE P**

## ENVIRONMENTAL PROTECTION AGENCY

### 40 CFR Part 52

[EPA-R08-OAR-2021-0678; FRL-9299-01-R8]

### Air Plan Approval; Montana; 2015 Ozone NAAQS Interstate Transport Requirements

**AGENCY:** Environmental Protection Agency (EPA).

**ACTION:** Proposed rule.

**SUMMARY:** The Clean Air Act (CAA) requires each State Implementation Plan (SIP) to contain adequate provisions prohibiting emissions that will significantly contribute to nonattainment or interfere with maintenance of air quality in other states. The State of Montana made a submission to the Environmental Protection Agency (EPA or Agency) to address these requirements for the 2015 ozone National Ambient Air Quality Standards (NAAQS). EPA is proposing to approve the submission for Montana as meeting the requirement that the SIP contains adequate provisions to prohibit emissions that will significantly contribute to nonattainment or interfere with maintenance of the 2015 ozone NAAQS in any other state.

**DATES:** Written comments must be received on or before March 7, 2022.

**ADDRESSES:** Submit your comments, identified by Docket ID No. EPA-R08-OAR-2021-0678, to the Federal Rulemaking Portal: <https://www.regulations.gov>. Follow the online instructions for submitting comments. Once submitted, comments cannot be edited or removed from [www.regulations.gov](https://www.regulations.gov). EPA may publish any comment received to its public docket. Do not submit electronically any information you consider to be Confidential Business Information (CBI) or other information whose disclosure is

restricted by statute. Multimedia submissions (audio, video, etc.) must be accompanied by a written comment. The written comment is considered the official comment and should include discussion of all points you wish to make. EPA will generally not consider comments or comment contents located outside of the primary submission (*i.e.*, on the web, cloud, or other file sharing system). For additional submission methods, the full EPA public comment policy, information about CBI or multimedia submissions, and general guidance on making effective comments, please visit <http://www2.epa.gov/dockets/commenting-epa-dockets>.

**Docket:** All documents in the docket are listed in the [www.regulations.gov](http://www.regulations.gov) index. Although listed in the index, some information is not publicly available, *e.g.*, CBI or other information whose disclosure is restricted by statute. Certain other material, such as copyrighted material, will be publicly available only in hard copy. Publicly available docket materials are available electronically in [www.regulations.gov](http://www.regulations.gov). To reduce the risk of COVID-19 transmission, for this action we do not plan to offer hard copy review of the docket. Please email or call the person listed in the **FOR FURTHER INFORMATION CONTACT** section if you need to make alternative arrangements for access to the docket.

**FOR FURTHER INFORMATION CONTACT:** Ellen Schmitt, Air and Radiation Division, EPA, Region 8, Mailcode 8ARD-IO, 1595 Wynkoop Street, Denver, Colorado 80202-1129, telephone number: (303) 312-6728, email address: [schmitt.ellen@epa.gov](mailto:schmitt.ellen@epa.gov).

**SUPPLEMENTARY INFORMATION:** Throughout this document whenever “we,” “us,” or “our” is used, we mean EPA.

## I. Background

On October 1, 2015, EPA promulgated a revision to the ozone NAAQS (2015 ozone NAAQS), lowering the level of both the primary and secondary standards to 0.070 parts per million (ppm).<sup>1</sup> Section 110(a)(1) of the CAA requires states to submit, within 3 years after promulgation of a new or revised standard, SIP submissions meeting the applicable requirements of section 110(a)(2).<sup>2</sup> One of these applicable

<sup>1</sup> National Ambient Air Quality Standards for Ozone, Final Rule, 80 FR 65292 (October 26, 2015). Although the level of the standard is specified in the units of ppm, ozone concentrations are also described in parts per billion (ppb). For example, 0.070 ppm is equivalent to 70 ppb.

<sup>2</sup> SIP revisions that are intended to meet the applicable requirements of section 110(a)(1) and (2)

requirements is found in section 110(a)(2)(D)(i)(I), otherwise known as the good neighbor provision, which generally requires SIPs to contain adequate provisions to prohibit in-state emissions activities from having certain adverse air quality effects on other states due to interstate transport of pollution. There are four so-called “prongs” within CAA section 110(a)(2)(D)(i); section 110(a)(2)(D)(i)(I) contains prongs 1 and 2. Under prongs 1 and 2 of the good neighbor provision, a SIP for a new or revised NAAQS must contain adequate provisions prohibiting any source or other type of emissions activity within the state from emitting air pollutants in amounts that will significantly contribute to nonattainment of the NAAQS in another state (prong 1) or interfere with maintenance of the NAAQS in another state (prong 2). EPA and states must give independent significance to prong 1 and prong 2 when evaluating downwind air quality problems under CAA section 110(a)(2)(D)(i)(I).<sup>3</sup>

We note that EPA has addressed the interstate transport requirements of CAA section 110(a)(2)(D)(i)(I) with respect to prior ozone NAAQS in several regional regulatory actions, including the Cross-State Air Pollution Rule (CSAPR), which addressed interstate transport with respect to the 1997 ozone NAAQS as well as the 1997 and 2006 fine particulate matter standards,<sup>4</sup> the Cross-State Air Pollution Rule Update (CSAPR Update) with respect to the 2008 ozone NAAQS, and, most recently, the Revised CSAPR Update for the 2008 ozone NAAQS.<sup>5</sup> <sup>6</sup>

Through the development and implementation of CSAPR and other regional rulemakings pursuant to the good neighbor provision,<sup>7</sup> EPA, working

of the CAA are often referred to as infrastructure SIPs and the applicable elements under section 110(a)(2) are referred to as infrastructure requirements.

<sup>3</sup> See *North Carolina v. EPA*, 531 F.3d 896, 909–911 (2008).

<sup>4</sup> See 76 FR 48208 (August 8, 2011).

<sup>5</sup> In 2019, the D.C. Circuit Court of Appeals remanded the CSAPR Update to the extent it failed to require upwind states to eliminate their significant contribution by the next applicable attainment date by which downwind states must come into compliance with the NAAQS, as established under CAA section 181(a). *Wisconsin v. EPA*, 938 F.3d 303, 313 (D.C. Cir. 2019).

<sup>6</sup> The Revised Cross-State Air Pollution Rule Update for the 2008 ozone NAAQS (86 FR 23054 (April 30, 2021)) was signed by the EPA Administrator on March 15, 2021 and responded to the remand of the CSAPR Update (81 FR 74504 (October 26, 2016)) and the vacatur of a separate rule, the CSAPR Close-Out (83 FR 65878 (December 21, 2018)) by the D.C. Circuit. *Wisconsin v. EPA*, 938 F.3d 303 (D.C. Cir. 2019); *New York v. EPA*, 781 F. App'x. 4 (D.C. Cir. 2019).

<sup>7</sup> In addition to the CSAPR rulemakings, other regional rulemakings addressing ozone transport

in partnership with states, developed the following four-step interstate transport framework to address the requirements of the good neighbor provision for the ozone NAAQS: (1) Identify downwind air quality problems; (2) identify upwind states that impact those downwind air quality problems sufficiently such that they are considered “linked” and therefore warrant further review and analysis; (3) identify the emissions reductions necessary (if any), considering air-quality and cost factors, to prevent linked upwind states identified in step 2 from contributing significantly to nonattainment or interfering with maintenance of the NAAQS at the locations of the downwind air quality problems; and (4) adopt permanent and enforceable measures needed to achieve those emissions reductions.

EPA has released several documents containing information relevant to evaluating interstate transport with respect to the 2015 ozone NAAQS. First, on January 6, 2017, EPA published a notice of data availability (NODA) with preliminary interstate ozone transport modeling with projected ozone design values (DVs) for 2023 using a 2011 base year modeling platform, on which we requested public comment.<sup>8</sup> In the NODA, EPA used the year 2023 as the analytic year for this preliminary modeling because that year aligns with the expected attainment year for Moderate ozone nonattainment areas for the 2015 ozone NAAQS.<sup>9</sup> On October 27, 2017, we released a memorandum (2017 memorandum) containing updated modeling data for 2023, which incorporated changes made in response to comments on the NODA, and noted that the modeling may be useful for states developing SIPs to address good neighbor obligations for the 2008 ozone NAAQS.<sup>10</sup> On March 27, 2018, we issued a memorandum (March 2018 memorandum) noting that the same 2023 modeling data released in the 2017 memorandum could also be useful for identifying potential downwind air

include the NO<sub>x</sub> SIP Call, 63 FR 57356 (October 27, 1998), and the Clean Air Interstate Rule (CAIR), 70 FR 25162 (May 12, 2005).

<sup>8</sup> See Notice of Availability of the Environmental Protection Agency’s Preliminary Interstate Ozone Transport Modeling Data for the 2015 Ozone National Ambient Air Quality Standard (NAAQS), 82 FR 1733 (January 6, 2017).

<sup>9</sup> 82 FR 1733, 1735 (January 6, 2017).

<sup>10</sup> See Information on the Interstate Transport State Implementation Plan Submissions for the 2008 Ozone National Ambient Air Quality Standards under Clean Air Act Section 110(a)(2)(D)(i)(I), October 27, 2017, available in the docket for this action as “October 2017 Memorandum” or at <https://www.epa.gov/interstate-air-pollution-transport/interstate-air-pollution-transport-memos-and-notices>.

quality problems with respect to the 2015 ozone NAAQS at step 1 of the four-step interstate transport framework.<sup>11</sup> The March 2018 memorandum also included the then newly available contribution modeling results to assist states in evaluating their impact on potential downwind air quality problems for the 2015 ozone NAAQS under step 2 of the interstate transport framework. EPA subsequently issued two more memoranda in August and October 2018, providing additional information to states developing good neighbor SIP submissions for the 2015 ozone NAAQS concerning, respectively, potential contribution thresholds that may be appropriate to apply in step 2 of the framework, and considerations for identifying downwind areas that may have problems maintaining the standard at step 1 of the framework.<sup>12</sup>

On October 30, 2020, in the notice of proposed rulemaking for the Revised CSAPR Update, EPA released and accepted public comment on updated 2023 modeling that used a 2016 emissions platform developed under the EPA/Multi-Jurisdictional Organization (MJO)/state collaborative project as the primary source for the base year and future year emissions data.<sup>13</sup> On March 15, 2021, EPA signed the final Revised CSAPR Update using the same modeling released at proposal.<sup>14</sup> Although Montana relied on the modeling included in the March 2018 memo to develop their SIP submission as EPA had suggested, EPA now proposes to primarily rely on the updated and newly available 2016 base year modeling in evaluating these submissions. By using the Revised CSAPR Update modeling results, EPA is using the most current and technically

appropriate information as the primary basis for this proposed rulemaking.<sup>15</sup> EPA's independent analysis, which evaluated historical monitoring data, recent DVs, and emissions trends, in addition to the Revised CSAPR Update modeling, provides support and further substantiates the results of the 2011 platform modeling relied on by Montana. Section III of this document and the Air Quality Modeling technical support document (TSD) included in the docket for this proposal contain additional detail on Revised CSAPR Update modeling.<sup>16</sup>

In the CSAPR, CSAPR Update, and the Revised CSAPR Update, EPA used a threshold of one percent of the NAAQS to determine whether a given upwind state was "linked" at step 2 of the interstate transport framework and would, therefore, contribute to downwind nonattainment and maintenance sites identified in step 1. If a state's impact did not equal or exceed the one percent threshold, the upwind state was not "linked" to a downwind air quality problem, and EPA, therefore, concluded the state would not significantly contribute to nonattainment or interfere with maintenance of the NAAQS in the downwind states. However, if a state's impact equaled or exceeded the one percent threshold, the state's emissions were further evaluated in step 3, considering both air quality and cost considerations, to determine what, if any, emissions might be deemed "significant" and, thus, must be eliminated under the good neighbor provision. EPA is relying on the one percent threshold for the purpose of evaluating Montana's contribution to nonattainment or maintenance of the 2015 ozone NAAQS in downwind areas.

Several D.C. Circuit court decisions address the issue of the relevant analytic year for the purposes of evaluating ozone transport air-quality problems. On September 13, 2019, the D.C. Circuit issued a decision in *Wisconsin v. EPA*,

remanding the CSAPR Update to the extent that it failed to require upwind states to eliminate their significant contribution by the next applicable attainment date by which downwind states must come into compliance with the NAAQS, as established under CAA section 181(a).<sup>17</sup>

On May 19, 2020, the D.C. Circuit issued a decision in *Maryland v. EPA* that cited the *Wisconsin* decision in holding that EPA must assess the impact of interstate transport on air quality at the next downwind attainment date, including Marginal area attainment dates, in evaluating the basis for EPA's denial of a petition under CAA section 126(b).<sup>18</sup> The court noted that "section 126(b) incorporates the Good Neighbor Provision," and, therefore, "EPA must find a violation [of section 126] if an upwind source will significantly contribute to downwind nonattainment at the next downwind attainment deadline. Therefore, the agency must evaluate downwind air quality at that deadline, not at some later date." *Id.* at 1204 (emphasis added). EPA interprets the court's holding in *Maryland* as requiring the Agency, under the good neighbor provision, to assess downwind air quality by no later than the next applicable attainment date, including a Marginal area attainment date under CAA section 181 for ozone nonattainment.<sup>19</sup>

However, the Marginal area attainment date for the 2015 ozone NAAQS was August 3, 2021.<sup>20</sup> EPA does not believe it would be appropriate to focus its analysis on an attainment date that is wholly in the past because the Agency interprets the good neighbor provision as forward looking. *See* 86 FR 23054 at 23074; *see also Wisconsin*, 938 F.3d at 322. Consequently, as this action is being proposed after the 2021 attainment date (as well as after the end of the 2021 ozone season), EPA proposes to use 2023 as an appropriate

<sup>11</sup> See Information on the Interstate Transport State Implementation Plan Submissions for the 2015 Ozone National Ambient Air Quality Standards under Clean Air Act Section 110(a)(2)(D)(i)(I), March 27, 2018, available in the docket for this action as "March 2018 Memorandum."

<sup>12</sup> See Analysis of Contribution Thresholds for Use in Clean Air Act Section 110(a)(2)(D)(i)(I) Interstate Transport State Implementation Plan Submissions for the 2015 Ozone National Ambient Air Quality Standards, August 31, 2018 ("August 2018 memorandum"), and Considerations for Identifying Maintenance Receptors for Use in Clean Air Act Section 110(a)(2)(D)(i)(I) Interstate Transport State Implementation Plan Submissions for the 2015 Ozone National Ambient Air Quality Standards, October 19, 2018, available in the docket for this action as "Maintenance Receptors Memo Oct2018" or at <https://www.epa.gov/airmarkets/memo-and-supplemental-information-regarding-interstate-transport-sips-2015-ozone-naaqs>.

<sup>13</sup> See 85 FR 68964, 68981. The underlying modeling files are available for public review in the docket for the Revised CSAPR Update (EPA-HQ-OAR-2020-0272).

<sup>14</sup> See 86 FR 23054 at 23075, 23164 (April 30, 2021).

<sup>15</sup> EPA recently made available updated modeling results on its website but was not able to incorporate those results into this proposal prior to signature. *See* <https://www.epa.gov/air-emissions-modeling/2016v2-platform>. In any case, these results corroborate the prior EPA modeling on which this proposal relies with respect to Montana.

<sup>16</sup> See "Air Quality Modeling Technical Support Document for the Final Revised Cross-State Air Pollution Rule Update," 86 FR 23054 (April 30, 2021), available in the docket for this action. This TSD was originally developed to support EPA's action in the Revised CSAPR Update, as relating to outstanding good neighbor obligations under the 2008 ozone NAAQS. While developed in this separate context, the data and modeling outputs, including interpolated design values for 2021, may be evaluated with respect to the 2015 ozone NAAQS and used in support of this proposal.

<sup>17</sup> 938 F.3d 303, 313.

<sup>18</sup> *Maryland v. EPA*, 958 F.3d 1185, 1203–04 (D.C. Cir. 2020).

<sup>19</sup> We note that the court in *Maryland* did not have occasion to evaluate circumstances in which EPA may determine that an upwind linkage to a downwind air quality problem exists at steps 1 and 2 of the interstate transport framework by a particular attainment date, but for reasons of impossibility or profound uncertainty the Agency is unable to mandate upwind pollution controls by that date. *See Wisconsin*, 938 F.3d at 320. The D.C. Circuit noted in *Wisconsin* that upon a sufficient showing, these circumstances may warrant flexibility in effectuating the purpose of the good neighbor provision. Such circumstances are not at issue in the present proposal.

<sup>20</sup> CAA section 181(a); 40 CFR 51.1303; Additional Air Quality Designations for the 2015 Ozone National Ambient Air Quality Standards, 83 FR 25776 (June 4, 2018, effective Aug. 3, 2018).



analytic year in this action. The year 2023 contains the last full ozone season before the next downwind attainment date, which is the August 3, 2024, Moderate area attainment date. (Historically, EPA has considered the full ozone season prior to the attainment date as supplying an appropriate analytic year for assessing Montana's good neighbor obligations.) EPA acknowledges that the first order directive for the timing of good neighbor compliance is "as expeditiously as practicable." See CAA section 181(a)(1); 938 F.3d at 313. EPA believes that an assessment of future air quality in the 2023 analytic year is as expeditiously as practicable. Should any emission reductions be required under the four-step interstate transport framework (though, to be clear, none are found to be necessary for Montana in this proposal), EPA believes 2023 is the earliest ozone season by which such reductions would be possible. Therefore, EPA has analyzed projected ozone air quality and Montana's emissions for purposes of the good neighbor provision using the 2023 analytic year.

## II. Montana Submission

On October 1, 2018, EPA received a SIP revision from the State of Montana addressing the CAA section 110(a)(2)(D)(i)(I) interstate transport requirements for the 2015 ozone NAAQS. Montana relied on the results of EPA's modeling for the 2015 ozone NAAQS contained in the March 2018 memorandum to identify downwind nonattainment and maintenance receptors that may be impacted by emissions from sources in Montana in the year 2023. These results indicated the State's greatest impact on any potential downwind nonattainment or maintenance receptor would be 0.10 ppb. Referencing the March 2018 memorandum modeling, this level of impact from Montana was found in Brazoria, Texas (monitoring site 480391004), Tarrant, Texas (monitoring site 484392003), and Milwaukee, Wisconsin (monitoring site 550790085). Montana compared this value to a screening threshold of 0.70 ppb, representing one percent of the 2015 ozone NAAQS. Because Montana's impacts to receptors in downwind states are projected to be less than 0.70 ppb in 2023, the State concluded that emissions from sources within Montana will not significantly contribute to nonattainment or interfere with maintenance of the 2015 ozone NAAQS in any other state.

Montana's October 2018 good neighbor SIP submission also lists the

State's regulations for controlling ozone precursors. These rules and regulations are included in ARM Title 17, Chapter 8, subchapters 7, 8, 9, 10, 16, and 17.

## III. EPA Evaluation of Montana's Submission

Montana's SIP submission relies on analysis of the year 2023 (using a 2011 base year platform) to show that the State does not significantly contribute to nonattainment or interfere with maintenance of the 2015 ozone NAAQS in any other state. As explained in Section I of this proposal, EPA has conducted an updated analysis for the 2023 analytical year (using a 2016 base year platform) and proposed to rely primarily on this updated modeling to evaluate Montana's transport SIP submission. This updated modeling corroborates Montana's conclusion that the State will not significantly contribute to nonattainment or interfere with maintenance of the 2015 ozone NAAQS in any other state.<sup>21</sup> While EPA has focused its analysis in this document on the year 2023, modeling data in the record for a future analytic year, 2028, confirm that no new linkages to downwind receptors are projected in later years. This is consistent with an overall, long-term downward trend in emissions from the State.

In step 1 of the four-step interstate framework, we identify locations where the Agency expects there to be nonattainment or maintenance receptors for the 2015 8-hour ozone NAAQS in the 2023 analytic future year, using the 2016 base year modeling platform. Where EPA's analysis shows that an area or site does not fall under the definition of a nonattainment or maintenance receptor in 2023, that site is excluded from further analysis under EPA's four step interstate transport framework. For areas that are identified as a nonattainment or maintenance receptor in 2023, we proceed to the next step of our four-step framework by identifying the upwind state's contribution to those receptors.

EPA's approach to identifying ozone nonattainment and maintenance receptors in this proposal is consistent with the approach used in previous transport rulemakings and is consistent with the D.C. Circuit's direction in *North Carolina* to give independent consideration to both the "contribute significantly to nonattainment" and the

<sup>21</sup> See 86 FR 23054 (April 30, 2021). The results of this modeling are included in a spreadsheet in the docket for this action. The underlying modeling files are available for public access in the docket for the Revised CSAPR Update (EPA-HQ-OAR-2020-0272).

"interfere with maintenance" prongs of CAA section 110(a)(2)(D)(i)(I).<sup>22</sup>

For the purpose of this proposal, EPA identifies nonattainment receptors as those monitoring sites that are projected to have average design values that exceed the NAAQS and that are also measuring nonattainment based on the most recent monitored design values. This approach is consistent with prior transport rulemakings, such as the CSAPR Update, where EPA defined nonattainment receptors as those areas that both currently monitor nonattainment and that EPA projects will be in nonattainment in the future analytic year.<sup>23</sup>

In addition, in this proposal, EPA identifies a receptor to be a "maintenance" receptor for purposes of defining interference with maintenance, consistent with the method used in the CSAPR and upheld by the D.C. Circuit in *EME Homer City Generation, L.P. v. EPA*, 795 F.3d 118, 136 (D.C. Cir. 2015).<sup>24</sup> Specifically, monitoring sites with a projected maximum design value in 2023 that exceeds the NAAQS are considered maintenance receptors. EPA's method of defining these receptors takes into account both measured data and projections based on modeling analysis.

Recognizing that nonattainment receptors are also, by definition, maintenance receptors, EPA often uses the term "maintenance-only" to refer to receptors that are not also nonattainment receptors. Consistent with the methodology described above, monitoring sites with a projected maximum design value that exceeds the NAAQS, but with a projected average design value that is below the NAAQS, are identified as maintenance-only receptors. In addition, those sites that are currently measuring ozone concentrations below the level of the applicable NAAQS, but are projected to be nonattainment based on the average design value and that, by definition, are projected to have a maximum design value above the standard are also identified as maintenance-only receptors.

<sup>22</sup> 531 F.3d at 910–911 (holding that EPA must give "independent significance" to each prong of CAA section 110(a)(2)(D)(i)(I)).

<sup>23</sup> See 81 FR 74504 (October 26, 2016). Revised CSAPR Update also used this approach. See 86 FR 23054 (April 30, 2021). This same concept, relying on both current monitoring data and modeling to define nonattainment receptor, was also applied in CAIR. See 70 FR 25241 (January 14, 2005). See also *North Carolina*, 531 F.3d at 913–914 (affirming as reasonable EPA's approach to defining nonattainment in CAIR).

<sup>24</sup> See 76 FR 48208 (August 8, 2011). CSAPR Update and Revised CSAPR Update also used this approach. See 81 FR 74504 (October 26, 2016) and See 86 FR 23054 (April 30, 2021).

To evaluate future air quality in steps 1 and 2 of the interstate transport framework, EPA is using the 2016 and 2023 base case emissions developed under the EPA/MJO/state collaborative emissions modeling platform project as the primary source for base year and 2023 future year emissions data for this proposal.<sup>25</sup>

To quantify the contribution of emissions from specific upwind states on 2023 8-hour design values for the identified downwind nonattainment and maintenance receptors, EPA first performed nationwide, state-level ozone source apportionment modeling. The source apportionment modeling provided contributions to ozone from precursor emissions of anthropogenic nitrogen oxides (NO<sub>x</sub>) and volatile organic compounds (VOCs) in each state, individually. Details on the source apportionment modeling and the methods for determining contributions are in the Air Quality Modeling TSD in the docket.

The design values and contributions were examined to determine if Montana contributes at or above the threshold of one percent of the 2015 ozone NAAQS (0.70 ppb) to any downwind nonattainment or maintenance receptor. The data<sup>26</sup> indicate that the highest contribution in 2023 from Montana to downwind nonattainment or maintenance receptors is 0.08 ppb, well below the one percent of the NAAQS screening threshold. Montana contributes 0.08 ppb to two nonattainment receptors in Connecticut (monitoring site 90013007 in Fairfield County and monitoring site 90099002 in New Haven County) and to one maintenance receptor in Illinois (monitoring site 170314201 in Cook County).

EPA also analyzed emissions trends for ozone precursors in Montana to

support the findings from the air quality analysis. We focused on state-wide emissions of NO<sub>x</sub> and VOC.<sup>27</sup> Emissions from mobile sources, electric generating units (“EGUs”), industrial facilities, gasoline vapors, and chemical solvents are some of the major anthropogenic sources of ozone precursors. This evaluation looks at both past emissions trends, as well as projected trends. EPA notes that the projected VOC emissions are greater than historical emissions in recent years according to NEI data. However, EPA also notes that NO<sub>x</sub> emissions are the primary contributor to regional ozone formation in ozone transport, and for Montana, NO<sub>x</sub> emissions are projected to continue to decline. As a result of these NO<sub>x</sub> emissions reductions, Montana is projected to contribute below the one percent threshold in 2023 to projected nonattainment and maintenance receptors and is projected to continue to contribute below one percent in 2028, despite the greater projected VOC emissions. Projected ozone design values and contributions data for 2021, 2023, and 2028 can be found in the file “Ozone Design Values and Contributions Revised CSAPR Update.xlsx” in the docket for this action.

As shown in Table 1, for Montana, between 2015 and 2019, annual total NO<sub>x</sub> and VOC emissions have declined by 19 percent and 21 percent, respectively. Between 2016 and 2023, annual NO<sub>x</sub> emissions are projected to decline by 30 percent as a result of the implementation of existing control programs that will continue to decrease NO<sub>x</sub> in Montana as indicated by EPA’s most recent 2023 projected emissions.

As shown in Table 2, onroad and nonroad mobile source emissions collectively comprise a large portion of the State’s total anthropogenic NO<sub>x</sub> and

VOC. For example, in 2019, NO<sub>x</sub> emissions from mobile sources in Montana comprised 63 percent of total NO<sub>x</sub> emissions and 25 percent of total VOC emissions.

The large decrease in NO<sub>x</sub> emissions between 2016 emissions and projected 2023 emissions in Montana is primarily driven by reductions in emissions from onroad and nonroad mobile sources. EPA projects that the total anthropogenic NO<sub>x</sub> emissions and the highway and off highway VOC emissions will continue declining out to 2023 as newer vehicles and engines that are subject to the most recent, stringent mobile source standards replace older vehicles and engines.<sup>28</sup>

In summary, there is no evidence to suggest that the overall emissions trend for Montana demonstrated in Table 1 will suddenly reverse or spike in 2021 or 2022 compared to historical emissions levels or those projected for 2023. Further, there is no evidence that the projected NO<sub>x</sub> emissions trend out to 2023 and beyond would not continue to show a decline in emissions from Montana. In addition, EPA’s normal practice is to include in our modeling only changes in NO<sub>x</sub> or VOC emissions that result from final regulatory actions. Any potential changes in NO<sub>x</sub> or VOC emissions that may result from possible future or proposed regulatory actions are speculative.

This general downward trend in emissions in Montana adds support to the air quality analyses presented above and indicates that the contributions from emissions from sources in the State to ozone receptors in downwind states will generally continue to decline and remain below one percent of the NAAQS.

TABLE 1—ANNUAL EMISSIONS OF NO<sub>x</sub> AND VOC FROM ANTHROPOGENIC SOURCES IN MONTANA [tons per year]<sup>29</sup>

	2011	2012	2013	2014	2015	2016	2017	2018	2019	Projected 2023
NO <sub>x</sub> .....	108,605	108,895	109,184	109,474	103,417	92,623	88,663	85,882	84,040	64,567

<sup>25</sup> See 86 FR 23054 (April 30, 2021). The results of this modeling are included in a spreadsheet in the docket for this action. The underlying modeling files are available for public access in the docket for the Revised CSAPR Update (EPA-HQ-OAR-2020-0272).

<sup>26</sup> The data are given in the “Air Quality Modeling Technical Support Document for the Revised Cross-State Air Pollution Rule Update” and “Ozone Design Values and Contributions Revised CSAPR Update.xlsx,” which are included in the docket for this action.

<sup>27</sup> This is because ground-level ozone is not emitted directly into the air but is formed by

chemical reactions between ozone precursors, chiefly NO<sub>x</sub> and VOC, in the presence of sunlight. See 86 FR 23054, 23063.

<sup>28</sup> Tier 3 Motor Vehicle Emission and Fuel Standards (79 FR 23414, April 28, 2014); Mobile Source Air Toxics Rule (MSAT2) (72 FR 8428, February 26, 2007), Heavy-Duty Engine and Vehicle Standards and Highway Diesel Fuel Sulfur Control Requirements (66 FR 5002, January 18, 2001); Clean Air Nonroad Diesel Rule (69 FR 38957, June 29, 2004); Locomotive and Marine Rule (73 FR 25098, May 6, 2008); Marine Spark-Ignition and Small Spark-Ignition Engine Rule (73 FR 59034, October 8, 2008); New Marine Compression-Ignition Engines at or Above 30 Liters per Cylinder Rule (75 FR

22895, April 30, 2010); and Aircraft and Aircraft Engine Emissions Standards (77 FR 36342, June 18, 2012).

<sup>29</sup> The annual emissions data for the years 2011 through 2019 were obtained from EPA’s National Emissions Inventory website: <https://www.epa.gov/air-emissions-inventories/air-pollutant-emissions-trends-data>. Note that emissions from miscellaneous sources are not included in the State totals presented in Table 1. The emissions for 2023 are based on the 2016 emissions modeling platform. See “2005 thru 2019\_2021\_2023\_2028 Annual State Tier1 Emissions\_v3” and the Emissions Modeling TSD in the docket for this action.

TABLE 1—ANNUAL EMISSIONS OF NO<sub>x</sub> AND VOC FROM ANTHROPOGENIC SOURCES IN MONTANA—Continued  
[tons per year]<sup>29</sup>

	2011	2012	2013	2014	2015	2016	2017	2018	2019	Projected 2023
VOC .....	100,778	104,768	108,759	112,750	103,312	91,612	83,660	82,432	81,204	92,076

TABLE 2—ANNUAL EMISSIONS OF NO<sub>x</sub> AND VOC FROM ONROAD AND NONROAD VEHICLES IN MONTANA  
[tons per year]

	2011	2012	2013	2014	2015	2016	2017	2018	2019	Projected 2023
NO <sub>x</sub> .....	75,883	75,352	74,821	74,289	69,640	60,254	57,701	55,182	52,662	41,261
VOC .....	31,108	30,865	30,622	30,379	28,059	23,477	22,644	21,416	20,188	16,631

Thus, EPA’s evaluation of measured and monitored data, and contribution values in 2023, as discussed in this section, is consistent with conclusions made by Montana that emissions from sources in the State will not contribute to nonattainment or interfere with maintenance of the 2015 ozone NAAQS in any other state.

**IV. Proposed Action**

EPA is proposing to approve the October 1, 2018 SIP submittal as meeting the interstate transport requirements of CAA section 110(a)(2)(D)(i)(I) for the 2015 ozone NAAQS. At this time, EPA is not proposing action on the remaining infrastructure elements included in Montana’s submittal and will act on those elements in a future action.

The Agency is soliciting public comments on its proposed approval of the CAA section 110(a)(2)(D)(i)(I) element of Montana’s infrastructure SIP submittal for the 2015 ozone NAAQS. Significant comments will be considered before taking final action. Interested parties may participate in the Federal rulemaking procedure by submitting written comments to this proposed rule by following the instructions listed in the ADDRESSES section of this Federal Register.

**V. Statutory and Executive Order Reviews**

Under the Clean Air Act, the Administrator is required to approve a SIP submission that complies with the provisions of the Act and applicable Federal regulations. 42 U.S.C. 7410(k); 40 CFR 52.02(a). Thus, in reviewing SIP submissions, EPA’s role is to approve state choices, provided that they meet the criteria of the CAA. Accordingly, this proposed action merely approves state law as meeting Federal requirements and does not impose additional requirements beyond those

imposed by state law. For that reason, this proposed action:

- Is not a significant regulatory action subject to review by the Office of Management and Budget under Executive Orders 12866 (58 FR 51735, October 4, 1993) and 13563 (76 FR 3821, January 21, 2011);
  - Does not impose an information collection burden under the provisions of the Paperwork Reduction Act (44 U.S.C. 3501 *et seq.*);
  - Is certified as not having a significant economic impact on a substantial number of small entities under the Regulatory Flexibility Act (5 U.S.C. 601 *et seq.*);
  - Does not contain any unfunded mandate or significantly or uniquely affect small governments, as described in the Unfunded Mandates Reform Act of 1995 (Pub. L. 104–4);
  - Does not have federalism implications as specified in Executive Order 13132 (64 FR 43255, August 10, 1999);
  - Is not an economically significant regulatory action based on health or safety risks subject to Executive Order 13045 (62 FR 19885, April 23, 1997);
  - Is not a significant regulatory action subject to Executive Order 13211 (66 FR 28355, May 22, 2001);
  - Is not subject to requirements of section 12(d) of the National Technology Transfer and Advancement Act of 1995 (15 U.S.C. 272 note) because application of those requirements would be inconsistent with the Clean Air Act; and
  - Does not provide EPA with the discretionary authority to address, as appropriate, disproportionate human health or environmental effects, using practicable and legally permissible methods, under Executive Order 12898 (59 FR 7629, February 16, 1994).
- In addition, the SIP is not approved to apply on any Indian reservation land or in any other area where EPA or an Indian tribe has demonstrated that a

tribe has jurisdiction. In those areas of Indian country, the proposed rule does not have tribal implications and will not impose substantial direct costs on tribal governments or preempt tribal law as specified by Executive Order 13175 (65 FR 67249, November 9, 2000).

**List of Subjects in 40 CFR Part 52**

Environmental protection, Air pollution control, Incorporation by reference, Intergovernmental relations, Nitrogen dioxide, Ozone, Reporting and recordkeeping requirements, Volatile organic compounds.

**Authority:** 42 U.S.C. 7401 *et seq.*

Dated: January 27, 2022.

**KC Becker,**

*Regional Administrator, Region 8.*

[FR Doc. 2022–02111 Filed 2–2–22; 8:45 am]

**BILLING CODE 6560–50–P**

**FEDERAL COMMUNICATIONS COMMISSION**

**47 CFR Part 73**

[MB Docket No. 22–30; RM–11916; DA 22–66; FR ID 69356]

**Television Broadcasting Services  
Vernon, Alabama**

**AGENCY:** Federal Communications Commission.

**ACTION:** Proposed rule.

**SUMMARY:** The Commission has before it a petition for rulemaking filed by Alabama Educational Television Commission (Petitioner), requesting the allotment of reserved noncommercial educational channel \*4 at Vernon, Alabama, as the community’s first local service.

**DATES:** Comments must be filed on or before March 7, 2022 and reply comments on or before March 21, 2022.

**ADDRESSES:** Federal Communications Commission, Office of the Secretary, 45

L Street NE, Washington, DC 20554. In addition to filing comments with the FCC, interested parties should serve the Petitioner as follows: M. Scott Johnson, Esq., Smithwick & Belendiuk, PC, 5028 Wisconsin Avenue NW, Washington, DC 20016.

**FOR FURTHER INFORMATION CONTACT:** Joyce Bernstein, Media Bureau, at (202) 418–1647; or Joyce Bernstein, Media Bureau, at [Joyce.Bernstein@fcc.gov](mailto:Joyce.Bernstein@fcc.gov).

**SUPPLEMENTARY INFORMATION:** In support of its channel allotment request, the Petitioner states that Vernon is a community deserving of a new television broadcast service. According to the Petitioner, Vernon (pop. 5,551/2010 Census) has a mayor, Board of Registrars, Circuit Clerk, Judge Probate, Sheriff, and six-member City Council. The community also has police, fire, and utility departments, as well as a public library, regional hospital, airport, numerous businesses and places of worship, and its own Zip Code. In addition, the proposed allotment would allow the provision of noncommercial educational television service to areas not currently served by Alabama Educational Television Commission (AETC). The Petitioner states its intention to file an application for channel \*4, if allotted, and take all necessary steps to obtain a construction permit. The Commission concludes the request to amend the Table of Allotments warrants consideration. The Petitioner’s proposal would result in a first local service to Vernon consistent with the Commission’s television allotment policies. Channel \*4 can be allotted to Vernon, consistent with the minimum geographic spacing requirements for new digital television (DTV) allotments in § 73.623(d) of the Commission’s rules, at 33°54’44.26” N and 87°48’06.20” W. In addition, the allotment point complies with § 73.625(a)(1) of the rules as the entire community of Vernon is encompassed by the 35 dBμ contour.

This is a synopsis of the Commission’s *Notice of Proposed Rulemaking*, MB Docket No. 22–30; RM–11916; DA 22–30, adopted January 20, 2022, and released January 20, 2022. The full text of this document is available for download at <https://www.fcc.gov/edocs>. To request materials in accessible formats (braille, large print, computer diskettes, or audio recordings), please send an email to [FCC504@fcc.gov](mailto:FCC504@fcc.gov) or call the Consumer & Government Affairs Bureau at (202) 418–0530 (VOICE), (202) 418–0432 (TTY).

This document does not contain information collection requirements

subject to the Paperwork Reduction Act of 1995, Public Law 104–13. In addition, therefore, it does not contain any proposed information collection burden “for small business concerns with fewer than 25 employees,” pursuant to the Small Business Paperwork Relief Act of 2002, Public Law 107–198, *see* 44 U.S.C. 3506(c)(4). Provisions of the Regulatory Flexibility Act of 1980, 5 U.S.C. 601–612, do not apply to this proceeding.

Members of the public should note that all *ex parte* contacts are prohibited from the time a notice of proposed rulemaking is issued to the time the matter is no longer subject to Commission consideration or court review, *see* 47 CFR 1.1208. There are, however, exceptions to this prohibition, which can be found in § 1.1204(a) of the Commission’s rules, 47 CFR 1.1204(a).

*See* §§ 1.415 and 1.420 of the Commission’s rules for information regarding the proper filing procedures for comments, 47 CFR 1.415 and 1.420.

**List of Subjects in 47 CFR Part 73**

Television.  
Federal Communications Commission.  
**Thomas Horan,**  
*Chief of Staff, Media Bureau.*

**Proposed Rule**

For the reasons discussed in the preamble, the Federal Communications Commission proposes to amend 47 CFR part 73 as follows:

**PART 73—RADIO BROADCAST SERVICES**

■ 1. The authority citation for part 73 continues to read as follows:

**Authority:** 47 U.S.C. 154, 155, 301, 303, 307, 309, 310, 334, 336, 339.

■ 2. In § 73.622(j), amend the Table of Allotments under Alabama by adding an entry for Vernon in alphabetical order to read as follows:

**§ 73.622 Digital television table of allotments.**

*	*	*	*	*
(j)	*	*	*	
	Community		Channel No.	
	<b>ALABAMA</b>			
	*	*	*	*
Vernon	.....		*4	
	*	*	*	*

[FR Doc. 2022–02212 Filed 2–2–22; 8:45 am]  
**BILLING CODE 6712–01–P**

**DEPARTMENT OF THE INTERIOR**

**Fish and Wildlife Service**

**50 CFR Part 17**

[Docket No. FWS–R8–ES–2020–0017; FF09E21000 FXES1111090FEDR 223]

RIN 1018–BF94

**Endangered and Threatened Wildlife and Plants; Designation of Critical Habitat for Tiehm’s Buckwheat**

**AGENCY:** Fish and Wildlife Service, Interior.

**ACTION:** Proposed rule.

**SUMMARY:** We, the U.S. Fish and Wildlife Service (Service), propose to designate critical habitat for the Tiehm’s buckwheat (*Eriogonum tiehmii*), which the Service has proposed to list as endangered under the Endangered Species Act of 1973, as amended (Act). In total, we propose to designate approximately 910 acres (368 hectares) in one unit in Nevada as critical habitat for Tiehm’s buckwheat. We also announce the availability of a draft economic analysis of the proposed critical habitat designation.

**DATES:** We will accept comments received or postmarked on or before April 4, 2022. Comments submitted electronically using the Federal eRulemaking Portal (*see ADDRESSES, below*) must be received by 11:59 p.m. Eastern Time on the closing date. We must receive requests for a public hearing, in writing, at the address shown in **FOR FURTHER INFORMATION CONTACT** by March 21, 2022.

**ADDRESSES:** *Written comments:* You may submit comments by one of the following methods:

(1) *Electronically:* Go to the Federal eRulemaking Portal: <https://www.regulations.gov>. In the Search box, enter the docket number or RIN for this rulemaking (presented above in the document headings). For best results, do not copy and paste either number; instead, type the docket number or RIN into the Search box using hyphens. Then, click on the Search button. On the resulting page, in the Search panel on the left side of the screen, under the Document Type heading, check the Proposed Rule box to locate this document. You may submit a comment by clicking on “Comment.”

(2) *By hard copy:* Submit by U.S. mail to: Public Comments Processing, Attn: FWS–R8–ES–2020–0017, U.S. Fish and Wildlife Service, MS: PRB/3W, 5275 Leesburg Pike, Falls Church, VA 22041–3803.

We request that you send comments only by the methods described above.

We will post all comments on <https://www.regulations.gov>. This generally means that we will post any personal information you provide us (see Information Requested, below, for more information).

**Availability of supporting materials:** The coordinates or plot points or both from which the critical habitat maps are generated are included in the decision file and are available at <https://www.regulations.gov> under Docket No. FWS-R8-ES-2020-0017. Any additional supporting information that we developed for this critical habitat designation will be available at <https://www.regulations.gov>.

**FOR FURTHER INFORMATION CONTACT:**

Marc Jackson, Field Supervisor, U.S. Fish and Wildlife Service, Reno Ecological Services Field Office, 1340 Financial Boulevard, Suite 234, Reno, NV 89502; telephone 775-861-6337. Persons who use a telecommunications device for the deaf (TDD) may call the Federal Relay Service at 800-877-8339.

**SUPPLEMENTARY INFORMATION:**

**Executive Summary**

*Why we need to publish a rule.* Under the Act, when we determine that any species is an endangered or threatened species, we are required to designate critical habitat, to the maximum extent prudent and determinable. Designations of critical habitat can be completed only by issuing a rule.

*What this document does.* This document proposes to designate critical habitat for Tiehm's buckwheat, which the Service has proposed to list as an endangered species under the Act, in a portion of Esmeralda County, Nevada.

*The basis for our action.* Under section 4(a)(3) of the Act, if we determine that a species is an endangered or threatened species we must, to the maximum extent prudent and determinable, designate critical habitat. Section 3(5)(A) of the Act defines critical habitat as (i) the specific areas within the geographical area occupied by the species, at the time it is listed in accordance with the provisions of section 4 of the Act, on which are found those physical or biological features (I) essential to the conservation of the species and (II) which may require special management considerations or protections; and (ii) specific areas outside the geographical area occupied by the species at the time it is listed in accordance with the provisions of section 4 of the Act, upon a determination by the Secretary that such areas are essential for the conservation of the species. Section 4(b)(2) of the Act states that the

Secretary must make the designation on the basis of the best scientific data available and after taking into consideration the economic impact, the impact on national security, and any other relevant impacts of specifying any particular area as critical habitat. The Secretary may exclude an area from the critical habitat designation if we determine that the benefits of such exclusion outweigh the benefits of specifying such area as part of the critical habitat, unless we determine, based on the best scientific data available, that the failure to designate such area will result in the extinction of the species.

**Abbreviations and Acronyms Used in This Proposed Rule**

For the convenience of the reader, a list of the abbreviations and acronyms used in this proposed rule follows:

Act = Endangered Species Act of 1973 (16 U.S.C. 1531 *et seq.*), as amended  
 BIA = Bureau of Indian Affairs  
 BLM = Bureau of Land Management  
 CBD = Center for Biological Diversity  
 CFR = Code of Federal Regulations  
 DEA = draft economic analysis  
 DoD = Department of Defense  
 FLPMA = Federal Land Policy and Management Act (43 U.S.C. 1701 *et seq.*)  
 FR = Federal Register  
 HCP = habitat conservation plan  
 IEC = Industrial Economics, Incorporated  
 IEM = incremental effects memorandum  
 INRMP = integrated natural resources management plan  
 Ioneer = Ioneer USA Corporation  
 NDF = Nevada Division of Forestry  
 NDNH = Nevada Division of Natural Heritage  
 NDOW = Nevada Department of Wildlife  
 NEPA = National Environmental Policy Act (42 U.S.C. 4321 *et seq.*)  
 RMP = resource management plan  
 Service = U.S. Fish and Wildlife Service  
 SSA = species status assessment  
 UNR = University of Nevada, Reno

**Information Requested**

We intend that any final action resulting from this proposed rule will be based on the best scientific and commercial data available and be as accurate and as effective as possible. Therefore, we request comments or information from other concerned governmental agencies, Native American Tribes, the scientific community, industry, or any other interested parties concerning this proposed rule.

We particularly seek comments concerning:

(1) The reasons why we should or should not designate habitat as "critical habitat" under section 4 of the Act (16 U.S.C. 1531 *et seq.*), including information to inform the following factors that the regulations identify as

reasons why designation of critical habitat may be not prudent:

(a) The species is threatened by taking or other human activity and identification of critical habitat can be expected to increase the degree of such threat to the species;

(b) The present or threatened destruction, modification, or curtailment of a species' habitat or range is not a threat to the species, or threats to the species' habitat stem solely from causes that cannot be addressed through management actions resulting from consultations under section 7(a)(2) of the Act;

(c) Areas within the jurisdiction of the United States provide no more than negligible conservation value, if any, for a species occurring primarily outside the jurisdiction of the United States; or

(d) No areas meet the definition of critical habitat.

(2) Specific information on:

(a) The amount and distribution of habitat for Tiehm's buckwheat;

(b) What areas, that were occupied at the time of proposed listing (86 FR 55775; October 7, 2021) and that contain the physical and biological feature essential to the conservation of the species and which may require special management considerations or protection, should be included in the designation and why;

(c) Any additional areas occurring within the range of the species (Esmeralda County, Nevada), that should be included in the designation because they (1) are occupied at the time of listing and contain the physical or biological features that are essential to the conservation of the species and that may require special management considerations, or (2) are unoccupied at the time of listing and are essential for the conservation of the species;

(d) Special management considerations or protections that may be needed in critical habitat areas we are proposing; and

(e) What areas not occupied at the time of proposed listing are essential for the conservation of the species. We particularly seek comments:

(i) Regarding whether occupied areas are adequate for the conservation of the species;

(ii) Providing specific information regarding whether or not unoccupied areas would, with reasonable certainty, contribute to the conservation of the species and contain the physical and biological feature essential to the conservation of the species; and

(iii) Explaining whether or not unoccupied areas fall within the definition of "habitat" at 50 CFR 424.02 and why.

(3) Land use designations and current or planned activities in the subject areas and their possible impacts on proposed critical habitat.

(4) Information on the projected and reasonably likely impacts of climate change on Tiehm's buckwheat proposed critical habitat.

(5) Any probable economic, national security, or other relevant impacts of designating any area that may be included in the final designation, and the benefits of including or excluding specific areas.

(6) Information on the extent to which the description of probable economic impacts in the draft economic analysis (DEA) is a reasonable estimate of the likely economic impacts and any applicable additional information.

(7) Whether any specific areas we are proposing for critical habitat designation should be considered for exclusion under section 4(b)(2) of the Act; whether the benefits of potentially excluding any specific area outweigh the benefits of including that area under section 4(b)(2) of the Act; and, in particular, whether any areas should be considered for exclusion under section 4(b)(2) of the Act based on a conservation program or plan, and why. These may include Federal, lands with permitted conservation plans covering the species in the area such as conservation easements, or non-permitted conservation agreements and partnerships that are under development. Detailed information regarding these plans, agreements, easements, and partnerships is also requested, including:

(a) The location and size of lands covered by the plan, agreement, easement, or partnership;

(b) The duration of the plan, agreement, easement, or partnership;

(c) Who holds or manages the land;

(d) What management activities are conducted;

(e) What land uses are allowable; and

(f) If management activities are beneficial to Tiehm's buckwheat and its habitat.

(8) Whether we could improve or modify our approach to designating critical habitat in any way to provide for greater public participation and understanding, or to better accommodate public concerns and comments.

Please include sufficient information with your submission (such as scientific journal articles or other publications) to allow us to verify any scientific or commercial information you include. If you request the exclusion of any areas from the final designation, please provide credible information regarding

the existence of a meaningful economic or other relevant impact supporting the benefit of exclusion of that particular area. Also, please note that submissions merely stating support for, or opposition to, the action under consideration without providing supporting information, although noted, will not be considered in making a determination, as section 4(b)(2) of the Act directs that the Secretary shall designate critical habitat on the basis of the best scientific information available.

You may submit your comments and materials concerning this proposed rule by one of the methods listed in **ADDRESSES**. We request that you send comments only by the methods described in **ADDRESSES**.

If you submit information via <https://www.regulations.gov>, your entire submission—including any personal identifying information—will be posted on the website. If your submission is made via a hardcopy that includes personal identifying information, you may request at the top of your document that we withhold this information from public review. However, we cannot guarantee that we will be able to do so. We will post all hardcopy submissions on <https://www.regulations.gov>.

Comments and materials we receive, as well as supporting documentation we used in preparing this proposed rule, will be available for public inspection on <https://www.regulations.gov>.

Because we will consider all comments and information we receive during the comment period, our final determination may differ from this proposal. Based on the new information we receive (and any comments on that new information), our final critical habitat designation may not include all areas proposed, may include some additional areas that meet the definition of critical habitat, and may exclude some areas if we find the benefits of exclusion outweigh the benefits of inclusion.

#### Public Hearing

Section 4(b)(5) of the Act provides for a public hearing on this proposal, if requested. Requests must be received by the date specified in **DATES**. Such requests must be sent to the address shown in **FOR FURTHER INFORMATION CONTACT**. We will schedule a public hearing on this proposal, if requested, and announce the date, time, and place of the hearing, as well as how to obtain reasonable accommodations, in the **Federal Register** and local newspapers at least 15 days before the hearing. For the immediate future, we will provide these public hearings using webinars that will be announced on the Service's

website, in addition to the **Federal Register**. The use of these virtual public hearings is consistent with our regulations at 50 CFR 424.16(c)(3).

#### Previous Federal Actions

It is our intent to discuss only those topics directly relevant to the designation of critical habitat for Tiehm's buckwheat in this document. For more information on the species, general information about Tiehm's buckwheat habitat, and previous Federal actions associated with listing Tiehm's buckwheat, refer to the 12-month finding published in the **Federal Register** on June 4, 2021 (86 FR 29975), the proposed listing rule published in the **Federal Register** on October 7, 2021 (86 FR 55775), and associated supporting documents available online at <https://www.regulations.gov> under Docket No. FWS-R8-ES-2020-0017.

#### Supporting Documents

The Service prepared a species status assessment (SSA) report (Service 2021a, entire), 12-month finding (86 FR 29975; June 4, 2021), and proposed listing rule (86 FR 55775; October 7, 2021) for Tiehm's buckwheat. The science provided in the SSA report, 12-month finding, and the proposed listing rule is the basis for this proposed critical habitat rule. The SSA report, 12-month finding, and proposed listing rule represent a compilation of the best scientific and commercial data available regarding a full status assessment of the species, including past, present, and future impacts (both negative and beneficial) affecting the species. The SSA report underwent independent peer review by scientists with expertise in botany, rare plant conservation, and plant ecology. The Service also sent the SSA report to three partner agencies, the Nevada Division of Forestry (NDF), the Nevada Division of Natural Heritage (NDNH), and the Bureau of Land Management (BLM), for review. We received comments from NDNH and BLM. Comments we received during peer and partner review were considered and incorporated into our SSA report.

Additionally, a team of Service biologists, in consultation with other species experts, collected and analyzed the best available information (including the information presented in the SSA report and proposed listing rule) to support this proposed critical habitat designation. As such, the science used and presented in this proposed rule represents a compilation of the best scientific information available.

In accordance with our joint policy on peer review published in the **Federal**

**Register** on July 1, 1994 (59 FR 34270), and our August 22, 2016, memorandum updating and clarifying the role of peer review of listing actions under the Act, we are seeking the expert opinions of at least three appropriate specialists regarding the science that informs this proposed rule. The purpose of peer review is to ensure that the science behind our critical habitat designation is based on scientifically sound data, assumptions, and analyses. We will consider any comments we receive, as appropriate, before making a final agency determination.

### Background

Critical habitat is defined in section 3 of the Act as:

(1) The specific areas within the geographical area occupied by the species, at the time it is listed in accordance with the provisions of section 4 of the Act, on which are found those physical or biological features:

(a) Essential to the conservation of the species, and

(b) Which may require special management considerations or protection; and

(2) Specific areas outside the geographical area occupied by the species at the time it is listed in accordance with the provisions of section 4 of the Act, upon a determination that such areas are essential for the conservation of the species.

Our regulations at 50 CFR 424.02 define the geographical area occupied by the species as an area that may generally be delineated around species' occurrences, as determined by the Secretary (*i.e.*, range). Such areas may include those areas used throughout all or part of the species' life cycle, even if not used on a regular basis (*e.g.*, migratory corridors, seasonal habitats, and habitats used periodically, but not solely, by vagrant individuals). Additionally, our regulations at 50 CFR 424.02 define the word "habitat," for the purposes of designating critical habitat only, as the abiotic and biotic setting that currently or periodically contains the resources and conditions necessary to support one or more life processes of a species.

Conservation, as defined under section 3 of the Act, means to use and the use of all methods and procedures that are necessary to bring an endangered or threatened species to the point at which the measures provided pursuant to the Act are no longer necessary.

Critical habitat receives protection under section 7 of the Act through the requirement that Federal agencies

ensure, in consultation with the Service, that any action they authorize, fund, or carry out is not likely to result in the destruction or adverse modification of critical habitat. The designation of critical habitat does not affect land ownership or establish a refuge, wilderness, reserve, preserve, or other conservation area. Such designation does not require implementation of restoration, recovery, or enhancement measures by non-Federal landowners. Where a landowner requests Federal agency funding or authorization for an action that may affect a listed species or critical habitat, the Federal agency would be required to consult with the Service under section 7(a)(2) of the Act. However, even if the Service were to conclude that the proposed activity would result in destruction or adverse modification of the critical habitat, the Federal action agency and the landowner are not required to abandon the proposed activity, or to restore or recover the species; instead, they must implement "reasonable and prudent alternatives" to avoid destruction or adverse modification of critical habitat.

Under the first prong of the Act's definition of critical habitat, areas within the geographical area occupied by the species at the time it was listed are included in a critical habitat designation if they contain physical or biological features (1) which are essential to the conservation of the species and (2) which may require special management considerations or protection. For these areas, critical habitat designations identify, to the extent known using the best scientific and commercial data available, those physical or biological features that are essential to the conservation of the species (such as space, food, cover, and protected habitat). In identifying those physical or biological features that occur in specific occupied areas, we focus on the specific features that are essential to support the life-history needs of the species, including, but not limited to, water characteristics, soil type, geological features, prey, vegetation, symbiotic species, or other features. A feature may be a single habitat characteristic or a more complex combination of habitat characteristics. Features may include habitat characteristics that support ephemeral or dynamic habitat conditions. Features may also be expressed in terms relating to principles of conservation biology, such as patch size, distribution distances, and connectivity.

Under the second prong of the Act's definition of critical habitat, we can designate critical habitat in areas outside the geographical area occupied

by the species at the time it is listed, upon a determination that such areas are essential for the conservation of the species. The implementing regulations at 50 CFR 424.12(b)(2) further delineate unoccupied critical habitat by setting out three specific parameters: (1) When designating critical habitat, the Secretary will first evaluate areas occupied by the species; (2) the Secretary will only consider unoccupied areas to be essential where a critical habitat designation limited to geographical areas occupied by the species would be inadequate to ensure the conservation of the species; and (3) for an unoccupied area to be considered essential, the Secretary must determine that there is a reasonable certainty both that the area will contribute to the conservation of the species and that the area contains one or more of those physical or biological features essential to the conservation of the species.

Section 4 of the Act requires that we designate critical habitat on the basis of the best scientific data available. Further, our Policy on Information Standards Under the Endangered Species Act (published in the **Federal Register** on July 1, 1994 (59 FR 34271)), the Information Quality Act (section 515 of the Treasury and General Government Appropriations Act for Fiscal Year 2001 (Pub. L. 106-554; H.R. 5658)), and our associated Information Quality Guidelines provide criteria, establish procedures, and provide guidance to ensure that our decisions are based on the best scientific data available. They require our biologists, to the extent consistent with the Act and with the use of the best scientific data available, to use primary and original sources of information as the basis for recommendations to designate critical habitat.

When we are determining which areas should be designated as critical habitat, our primary source of information is generally the information from an SSA report, listing rule, and other information developed during the listing process for the species. Additional information sources may include any generalized conservation strategy, criteria, or outline that may have been developed for the species; the recovery plan for the species, if one has been developed; articles in peer-reviewed journals; conservation plans developed by States and counties; scientific status surveys and studies; biological assessments; other unpublished materials; or experts' opinions or personal knowledge.

Habitat is dynamic, and species may move from one area to another over time. We recognize that critical habitat

designated at a particular point in time may not include all of the habitat areas that we may later determine are necessary for the recovery of the species. For these reasons, a critical habitat designation does not signal that habitat outside the designated area is unimportant or may not be needed for recovery of the species. Areas that are important to the conservation of the species, both inside and outside the critical habitat designation, may continue to be subject to: (1) Conservation actions implemented under section 7(a)(1) of the Act; (2) regulatory protections afforded by the requirement in section 7(a)(2) of the Act for Federal agencies to ensure their actions are not likely to jeopardize the continued existence of any endangered or threatened species; and (3) the prohibitions found in section 9 of the Act. Federally funded or permitted projects affecting listed species outside their designated critical habitat areas may still result in jeopardy findings in some cases. These protections and conservation tools will continue to contribute to recovery of the species. Similarly, critical habitat designations made on the basis of the best available information at the time of designation will not control the direction and substance of future recovery plans, habitat conservation plans (HCPs), or other species conservation planning efforts if new information available at the time of those planning efforts calls for a different outcome (*i.e.*, if new information sufficiently justifies the proposed conservation effort).

#### Prudency Determination

Section 4(a)(3) of the Act, as amended, and implementing regulations (50 CFR 424.12) require that, to the maximum extent prudent and determinable, the Secretary shall designate critical habitat at the time the species is determined to be an endangered or threatened species. Our regulations (50 CFR 424.12(a)(1)) state that the Secretary may, but is not required to, determine that a designation would not be prudent in the following circumstances:

(i) The species is threatened by taking or other human activity and identification of critical habitat can be expected to increase the degree of such threat to the species;

(ii) The present or threatened destruction, modification, or curtailment of a species' habitat or range is not a threat to the species, or threats to the species' habitat stem solely from causes that cannot be addressed through management actions resulting from

consultations under section 7(a)(2) of the Act;

(iii) Areas within the jurisdiction of the United States provide no more than negligible conservation value, if any, for a species occurring primarily outside the jurisdiction of the United States;

(iv) No areas meet the definition of critical habitat; or

(v) The Secretary otherwise determines that designation of critical habitat would not be prudent based on the best scientific data available.

There is currently no imminent threat of overutilization for commercial, recreational, scientific, or educational purposes (see 16 U.S.C. 1533(a)(1)(B)) identified for Tiehm's buckwheat, and identification and mapping of critical habitat is not expected to initiate any such threat. Threats of illegal collection or other human activity are not expected to increase due to the identification of critical habitat. Habitat impacts are a threat to the species, as noted in the proposed listing determination for Tiehm's buckwheat (86 FR 55775; October 7, 2021), and these impacts are from causes that can be addressed through management actions resulting from consultations under section 7(a)(2) of the Act. The species occurs solely within the United States, and available habitat, particularly those areas that meet the definition of critical habitat, provides significant conservation value.

Overall, our analysis of the best available scientific and commercial information indicates there are areas within the range of Tiehm's buckwheat that meet the definition of critical habitat. Therefore, because none of the circumstances listed in our regulations at 50 CFR 424.12(a)(1) have been met and because the Secretary has not identified other circumstances for which this designation of critical habitat would be not prudent, we have determined that the designation of critical habitat for Tiehm's buckwheat is prudent.

#### Critical Habitat Determinability

Having determined that designation is prudent, under section 4(a)(3) of the Act we must find whether critical habitat for Tiehm's buckwheat is determinable. Our regulations at 50 CFR 424.12(a)(2) state that critical habitat is not determinable when one or both of the following situations exist:

(i) Data sufficient to perform required analyses are lacking; or

(ii) The biological needs of the species are not sufficiently well known to identify any area that meets the definition of "critical habitat."

When critical habitat is not determinable, the Act allows the Service

an additional year to publish a critical habitat designation (16 U.S.C. 1533(b)(6)(C)(ii)).

We reviewed the available information pertaining to the biological needs of the species and habitat characteristics where the species is located. This and other information represent the best scientific data available and led us to conclude that the designation of critical habitat is determinable for Tiehm's buckwheat.

#### Physical or Biological Features Essential to the Conservation of the Species

In accordance with section 3(5)(A)(i) of the Act and regulations at 50 CFR 424.12(b), in determining which areas we will designate critical habitat from within the geographical area occupied by the species at the time of listing, we consider the physical or biological features that are essential to the conservation of the species and that may require special management considerations or protection.

The regulations at 50 CFR 424.02 define "physical or biological features essential to the conservation of the species" as the features that occur in specific areas and that are essential to support the life-history needs of the species, including, but not limited to, water characteristics, soil type, geological features, sites, prey, vegetation, symbiotic species, or other features. A feature may be a single habitat characteristic or a more complex combination of habitat characteristics. Features may include habitat characteristics that support ephemeral or dynamic habitat conditions. Features may also be expressed in terms relating to principles of conservation biology, such as patch size, distribution distances, and connectivity. For example, physical features essential to the conservation of the species might include gravel of a particular size required for spawning, alkali soil for seed germination, protective cover for migration, or susceptibility to flooding or fire that maintains necessary early-successional habitat characteristics. Biological features might include prey species, forage grasses, specific kinds or ages of trees for roosting or nesting, symbiotic fungi, or a particular level of nonnative species consistent with conservation needs of the listed species. The features may also be combinations of habitat characteristics and may encompass the relationship between characteristics or the necessary amount of a characteristic essential to support the life history of the species.

In considering whether features are essential to the conservation of the



species, the Service may consider an appropriate quality, quantity, and spatial and temporal arrangement of habitat characteristics in the context of the life-history needs, condition, and status of the species. These characteristics include, but are not limited to: (1) Space for individual and population growth and for normal behavior; (2) food, water, air, light, minerals, or other nutritional or physiological requirements; (3) cover or shelter; (4) sites for breeding, reproduction, or rearing (or development) of offspring; and (5) habitats that are protected from disturbance or are representative of the historic geographical and ecological distributions of a species.

Using the species' habitat, ecology, and life history, which are summarized below and are described more fully in the proposed listing rule (86 FR 55775; October 7, 2021) and the SSA report (Service 2021a, entire) that was developed to supplement the proposed listing rule, which are available at <https://www.regulations.gov> under Docket No. FWS-R8-ES-2020-0017, we considered the following habitat characteristics to derive the specific physical or biological features essential for the conservation of Tiehm's buckwheat.

#### Habitat Characteristics

Tiehm's buckwheat occurs between 5,906 and 6,234 feet (ft) (1,800 and 1,900 meters (m)) in elevation and on all aspects with slopes ranging from 0 to 50 degrees (Ioneer 2020a, p. 5; Morefield 1995, p. 11). The species occurs on dry, upland sites, subject only to occasional saturation by rain and snow, and is not found in association with free surface or subsurface waters (Morefield 1995, p. 11). Tiehm's buckwheat dominates the sparsely vegetated community in which it occurs, resulting in an open plant community with low plant cover and stature (Morefield 1995, p. 12). The vegetation varies from pure stands of Tiehm's buckwheat to sparse associations with a few other low-growing herbs and grass species, suggesting the species is not shade-tolerant and requires direct sunlight. The most common associates of Tiehm's buckwheat are species found in salt desert shrubland communities such as shadscale saltbush (*Atriplex confertifolia*), James' galleta (*Hilaria jamesii*), and alkali sacaton (*Sporobolus airoides*) (Morefield 1995, p. 12).

Like most terrestrial plants, Tiehm's buckwheat requires soil for physical support and as a source of nutrients and water. Tiehm's buckwheat is restricted to dry, open, relatively barren, light-

colored, rocky clay soils derived from an uncommon formation of interbedded claystones, shales, tuffaceous sandstones, and limestones (Ioneer 2020a, p. 5; Morefield 1995, p. 10). The soils are poor, with little development, lack an A horizon (top layer of mineral soil horizons), and are full of broken pieces of the parent bedrock (Ioneer 2020a, p. 5; Morefield 1995, p. 11). Soils are characterized by a variety of textures, and include clay soils, sandy clay loams, sandy loams, and loams (McClinton et al. 2020, p. 29). This specialized substrate is called channery soil, which consists of 15 to 35 percent thin, flat fragments of sandstone, shale, slate, limestone, or schist (United States Department of Agriculture (USDA) 2015, p. 7).

Tiehm's buckwheat is distributed on these soils along an outcrop of lithium clay in exposed former lake beds (Ioneer 2020a, p. 5). Soil pH ranges from 7.64 to 8.76 (Ioneer 2020a, p. 6). Initial soil sample analyses demonstrate that boron and carbonates were commonly present at excessive levels and that sulfur, calcium, and potassium were commonly present at high levels (Ioneer 2020a, p. 6). Further analyses indicate that soils occupied by Tiehm's buckwheat have on average extremely low phosphorus, low nitrogen, high boron, and high pH (McClinton et al. 2020, p. 35). There were significant differences in soil characteristics between soils occupied and unoccupied by Tiehm's buckwheat, including potassium, zinc, sulfur, and magnesium, which were on average lower in occupied soils, and boron, silt, bicarbonate, and pH, which were, on average, higher, although there was variation among subpopulations and adjacent, unoccupied sites (McClinton et al. 2020, pp. 35, 53). For example, boron was higher in Tiehm's buckwheat subpopulations 1, 2, and 3 than in subpopulations 4, 5, 6, 7, and 8 (Shams et al. 2021, pp. 4–5; McClinton et al. 2020, p. 30). Taking all soil components into consideration as well as results of greenhouse propagation experiments (McClinton et al. 2020, p. 36), there is a unique envelope of soil conditions in which Tiehm's buckwheat thrives that is different from adjacent unoccupied soils (Service 2021a, pp. 16–18).

Tiehm's buckwheat is a perennial plant species that is not rhizomatous or otherwise clonal. Therefore, like other buckwheat species, reproduction in Tiehm's buckwheat is presumed to occur via sexual means (*i.e.*, seed production and recruitment). As with most plant species, Tiehm's buckwheat does not require separate sites for reproduction other than the locations in which parent plants occur and any area

necessary for pollinators and seed dispersal. The primary seed dispersal agents of Tiehm's buckwheat are probably gravity, wind, and water (Morefield 1995, p. 14). Upon maturation of the fruit, seeds are likely to fall to the ground in the immediate vicinity of the parent plant, becoming lodged in the soil surface (Ioneer 2020a, p. 4). The number of seeds produced by individual Tiehm's buckwheat plants is variable with research demonstrating it can range anywhere from 50 to 450 seeds per plant (Service 2021a, pp. 15–16; McClinton et al. 2020, p. 22). We have no information on the longevity and viability of Tiehm's buckwheat seed in the soil seed bank (*i.e.*, natural storage of seeds within the soil of ecosystems) or what environmental cues are needed to trigger germination. However, many arid plants possess seed dormancy, enabling them to delay germination until receiving necessary environmental cues (Jurado and Flores 2005, entire; Pake and Venable 1996, pp. 1432–1434).

Buckwheat, in general, are sexual reproducers and insects are the most common pollinators (Gucker and Shaw 2019, pp. 5–6). Some studies have shown that buckwheat flowers can be pollinated by everything from bees and closely related spider predators (the Acroceridae (Cyrtidae)) to specialist pollinators, while other buckwheat species are also capable of self-pollination (Neel and Ellstrand 2003, p. 339; Archibald et al. 2001, p. 612; Moldenke 1976, pp. 20–25). Primary pollinators and insect visitors (insects that visit a plant to feed on pollen, nectar, or other flower parts, but may not necessarily play a role in pollination) to Tiehm's buckwheat include bees, wasps, beetles, and flies, and have an abundance and diversity exceptionally high for a plant community dominated by a single plant species (Service 2021a, p. 16; McClinton et al. 2020, pp. 11–22).

Successful transfer of pollen among Tiehm's buckwheat subpopulations may be inhibited if subpopulations are separated by distances greater than pollinators can travel and/or a pollinator's nesting or foraging habitat and behavior is negatively affected (Dorchin et al. 2013, entire; BLM 2012, p. 2; Cranmer et al. 2012, p. 562). Flight distances are generally correlated with body size in bees; larger bees are able to fly farther than smaller bees (Greenleaf et al. 2007, pp. 592–594; Gathmann and Tscharntke 2002, entire). There is evidence to suggest that larger bees, which are able to fly longer distances, do not need their habitat to remain contiguous, but it is more important that

the protected habitat is large enough to maintain floral diversity (BLM 2012, p. 18). While researchers have reported long foraging distance for solitary bees, the majority of individuals remain close to their nest, thus foraging distance tends to be 1,640 ft (500 m) or less (Antoine and Forrest 2021, p. 152; Danforth et al. 2019, p. 207; BLM 2012, p. 19). Nest building is common in some solitary wasps (Sphecidae and Pompilidae). However, the distances between hunting sites and nests are unknown for wasps, but many wasps probably hunt close to their nest (within 3 to 66 ft (1 to 20 m)) (O'Neil 2019, pp. 108–111, 152). Most butterflies, flies, and beetles find egg laying and feeding sites as they move across the landscape. The most common bee and wasp pollinators have a fixed location for their nest, and thus their nesting success is dependent on the availability of resources within their flight range (Xerces 2009, p. 14).

Many insect communities are known to be influenced not only by local habitat conditions, but also the surrounding landscape condition (Klein et al. 2004, p. 523; Inouye et al. 2015, pp. 119–121; Dorchin et al. 2013, entire; Tepedino et al. 2011, entire; Xerces 2009, pp. 11–26). In order for genetic exchange of Tiehm's buckwheat to occur, insect visitors and pollinators must be able to move freely between subpopulations. Alternative pollen and nectar sources (other plant species within the surrounding vegetation) are needed to support pollinators during times when Tiehm's buckwheat is not flowering. Conservation strategies that maintain plant-pollinator interactions, such as maintenance of diverse, herbicide-free nectar resources, would serve to attract a wide array of insects, including pollinators of Tiehm's buckwheat (BLM 2012, pp. 5–6, 19; Cranmer et al. 2012, p. 567).

### Summary

Based on our current knowledge of the physical or biological features and habitat characteristics required to sustain the species' life-history processes, we determine that the following physical and biological features are essential to the conservation of Tiehm's buckwheat:

1. *Plant community.* A plant community that supports all life stages of Tiehm's buckwheat includes:
  - a. Open to sparsely vegetated areas with low native plant cover and stature.
  - b. An intact, native vegetation assemblage that can include, but is not limited to, shadscale saltbush, James' galleta, and alkali sacaton to protect Tiehm's buckwheat from nonnative,

invasive plant species and provide the habitats needed by Tiehm's buckwheat's insect visitors and pollinators.

- c. A diversity of native plants whose blooming times overlap to provide insect visitors and pollinator species with flowers for foraging throughout the seasons and to provide nesting and egg-laying sites; appropriate nest materials; and sheltered, undisturbed habitat for hibernation and overwintering of pollinator species and insect visitors.

2. *Pollinators and insect visitors.*

Sufficient pollinators and insect visitors, particularly bees, wasps, beetles, and flies, are present for the species' successful reproduction and seed production.

3. *Hydrology.* Hydrology that is suitable for Tiehm's buckwheat consists of dry, open, relatively barren, upland sites subject to occasional precipitation from rain and/or snow for seed germination.

4. *Suitable soils.* Soils that are suitable for Tiehm's buckwheat consist of:
  - a. Light-colored, rocky soils derived from an uncommon formation of interbedded claystones, shales, tuffaceous sandstones, and limestones.
  - b. Soils that are poor, with little development; lack an A horizon; and are full of broken pieces of the parent bedrock.
  - c. Soils characterized by a variety of textures, and include clay soils, sandy clay loams, sandy loams, and loams.
  - d. Soils with pH ranges from 7.64 to 8.76.
  - e. Soils that commonly have on average boron and bicarbonates present at higher levels, and potassium, zinc, sulfur, and magnesium present at lower levels.

### Special Management Considerations or Protection

When designating critical habitat, we assess whether the specific areas within the geographical area occupied by the species at the time of listing contain features which are essential to the conservation of the species and which may require special management considerations or protection. The area proposed for designation as critical habitat may require some level of management to address the current and future threats to the physical and biological features essential to the conservation of Tiehm's buckwheat

A detailed discussion of threats to Tiehm's buckwheat and its habitat can be found in the SSA report (Service 2021a, pp. 23–48). The features essential to the conservation of Tiehm's buckwheat (plant community, pollinators and insect visitors, and

suitable hydrology and soils, required for the persistence of adults as well as successful reproduction of such individuals and the formation of a seedbank) may require special management considerations or protection to reduce threats; these threats are more fully described in the proposed listing rule (86 FR 55775; October 7, 2021). The current range of Tiehm's buckwheat is subject to anthropogenic threats such as mineral development, road development and off-highway vehicle (OHV) activity, livestock grazing, nonnative and invasive plant species, and climate change, as well as natural threats such as herbivory and potential effects associated with small population size (Service 2021a, pp. 23–54).

Management activities that could ameliorate these threats include (but are not limited to): Treatment of nonnative, invasive plant species; minimization of OHV access and placement of new roads away from the species and its habitat; regulations or agreements to minimize the effects of mineral exploration and development where the species resides; minimization of livestock use or other disturbances that disturb the soil or seeds; minimization of habitat fragmentation; and monitoring for herbivory. These activities would protect the physical or biological features for the species by preventing the loss of habitat; protecting the plant's habitat, pollinator and insect visitors, and soils from undesirable patterns or levels of disturbance; and facilitating management for desirable conditions that are necessary for Tiehm's buckwheat to fulfill its life-history needs.

Tiehm's buckwheat occurs entirely on Federal lands managed by the BLM. As described in the Tonopah Resource Management Plan (RMP), habitat for all federally listed endangered and threatened species and for all Nevada BLM sensitive species will be managed to maintain or increase current species populations. The introduction, reintroduction, or augmentation of Nevada BLM sensitive species may be allowed in coordination with Nevada Department of Wildlife (NDOW) or the Service, if it is deemed appropriate. Such actions will be considered on a case-by-case basis and will be subject to applicable procedures (BLM 1997, p. 9).

BLM has issued policy guidance to implement its obligations under the Federal Land Policy and Management Act (FLPMA; 43 U.S.C. 1701 *et seq.*). These include BLM's Integrated Vegetation Management Handbook H–1740–2, which guides BLM's various programs to use an interdisciplinary and

collaborative process to plan and implement a set of actions that improve biological diversity and ecosystem function that promote and maintain native plant communities that are resilient to disturbance and invasive species (BLM 2008, p. 2).

Additionally, the BLM Manual section MS-6840, release 6-125 (BLM 2008, pp. 1-48), provides guidance with respect to sensitive species. Tiehm’s buckwheat is managed as a BLM sensitive species; BLM sensitive species are defined as “species that require special management consideration to avoid potential future listing under the [Act]” (BLM 2008, Glossary, p. 5). Under this policy, BLM can initiate proactive conservation measures, including programs, plans, and management practices, to reduce or eliminate threats affecting the status of BLM sensitive species, or to improve the condition of the species’ habitat on BLM-administered lands (BLM 2008, MS-6840.02, MS-6840.06.2.C., and definition of “conservation,” pp. 3, 37, and Glossary 2).

In response to the September 2020 herbivory event on Tiehm’s buckwheat subpopulations, BLM has been monitoring the species. Photo plots were established near undamaged plants in subpopulations 1, 3, and 6 to help determine whether herbivory is continuing (Crosby 2020a, pers. comm.; Crosby, 2020b, pers. comm.). Ocular estimates from the photo plots indicate that herbivory is not ongoing (Crosby, 2020b, pers. comm.). Game cameras that were installed by BLM when damage to the species was first reported were removed in mid-November 2020, but may be reinstalled if deemed necessary (Crosby, 2020a, pers. comm.).

**Criteria Used To Identify Critical Habitat**

As required by section 4(b)(2) of the Act, we use the best scientific data available to designate critical habitat. In accordance with the Act and our

implementing regulations at 50 CFR 424.12(b), we review available information pertaining to the habitat requirements of the species and identify specific areas within the geographical area occupied by the species at the time of listing and any specific areas outside the geographical area occupied by the species to be considered for designation as critical habitat. We are not currently proposing to designate any areas outside the geographical area occupied by the species because we have not identified any unoccupied areas that meet the definition of critical habitat. The occupied areas are sufficient for the conservation of the species because the physical and biological features that support the plant occur there. The areas outside of the occupied area do not support these physical and biological features and we are not confident that they would support populations of Tiehm’s buckwheat.

We are proposing to designate one occupied critical habitat unit for Tiehm’s buckwheat. The one unit is comprised of approximately 910 acres (ac) (368 hectares (ha)) in Nevada and is completely on lands under Federal (BLM) land ownership. The unit was determined using location information for Tiehm’s buckwheat from E.M. Strategies and the NDNH (Kuyper 2019, entire; Morefield 2010, entire; Morefield 2008, entire). These locations were classified into one discrete population, with eight subpopulations, based on mapping standards devised by NatureServe and its network of Natural Heritage Programs (NatureServe 2004, entire). This unit includes the physical footprint of where the plants currently occur, as well as their immediate surroundings out to 1,640 ft (500 m) in every direction from the periphery of each subpopulation. This area of surrounding habitat contains components of the physical and biological features (*i.e.*, the pollinator community and its requisite native vegetative assembly) necessary to

support the life-history needs of Tiehm’s buckwheat (Antoine and Forrest 2021, p. 152; O’Neil 2019, pp. 108-111, 152; Danforth et al. 2019, p. 207; BLM 2012, p. 19; Xerces 2009, p. 14; Greenleaf et al. 2007, pp. 592-594; Gathmann and Tschardtke 2002, entire). This essential habitat configuration was based on the best available nesting, egg-laying, and foraging information for the bee, wasp, beetle, and fly pollinators and insect visitors of Tiehm’s buckwheat (McClinton et al. 2020, p. 18), as most insect communities are known to be influenced not only by local habitat conditions, but also the surrounding landscape conditions (Klein et al. 2004, p. 523; Inouye et al. 2015, pp. 119-121; Dorchin et al. 2013, entire; Tepedino et al. 2011, entire; Xerces 2009, pp. 11-26).

The critical habitat designation is defined by the map, as modified by any accompanying regulatory text, presented at the end of this document under Proposed Regulation Promulgation. We include more detailed information on the boundaries of the critical habitat designation in the preamble of this document. We will make the coordinates or plot points or both on which the map is based available to the public on <https://www.regulations.gov> at Docket No. FWS-R8-ES-2020-0017, and at the field office responsible for the designation (see **FOR FURTHER INFORMATION CONTACT** above).

**Proposed Critical Habitat Designation**

We are proposing one unit as critical habitat for Tiehm’s buckwheat. The unit is considered occupied at the time of listing. The critical habitat area, the Rhyolite Ridge area of the Silver Peak Range in Esmeralda County, Nevada, that we describe below constitutes our current best assessment of areas that meet the definition of critical habitat for Tiehm’s buckwheat. Table 1(below) shows the proposed critical habitat unit and its approximate area.

TABLE 1—PROPOSED CRITICAL HABITAT UNIT FOR TIEHM’S BUCKWHEAT (ENGONUM TICHMII)  
[Area estimates reflect all lands within the critical habitat boundary.]

Unit name	Federally owned land *		Total area	
	acres	hectares	acres	hectares
Rhyolite Ridge Unit .....	910	368		
.....	910	368		

\* These lands are Federal lands managed by the Bureau of Land Management (BLM).

We present brief a description of the critical habitat unit, and reasons why it meets the definition of critical habitat for Tiehm’s buckwheat, below.

*Rhyolite Ridge Unit*

The Rhyolite Ridge Unit consists of approximately 910 ac (368 ha) of

Federal land. This unit is located approximately 13 miles (21 kilometers) west of Silver Peak in Esmeralda County, Nevada. Cave Springs Road, a

rural, county unpaved road, bisects the unit. One hundred percent of this unit is on Federal lands managed by the BLM. This unit is currently occupied and contains the single population comprised of eight subpopulations of Tiehm's buckwheat. This unit is essential to the conservation and recovery of Tiehm's buckwheat because it supports all of the habitat that is occupied by Tiehm's buckwheat across the species' range. This unit currently has all of the physical and biological features described above essential to the conservation of the species, including a plant community that supports all life stages of Tiehm's buckwheat; sufficient pollinators and insect visitors, particularly bees, wasps, beetles, and flies; hydrology suitable for Tiehm's buckwheat that consists of dry, open, relatively barren, upland sites subject to occasional precipitation from rain and/or snow; and soils that are suitable for Tiehm's buckwheat. Special management considerations or protection may be required to address mineral development, road development and OHV activity, livestock grazing, nonnative invasive plant species, and herbivory (see Special Management Considerations or Protection).

### Effects of Critical Habitat Designation

#### Section 7 Consultation

Section 7(a)(2) of the Act requires Federal agencies, including the Service, to ensure that any action they fund, authorize, or carry out is not likely to jeopardize the continued existence of any endangered species or threatened species or result in the destruction or adverse modification of designated critical habitat of such species. In addition, section 7(a)(4) of the Act requires Federal agencies to confer with the Service on any agency action which is likely to jeopardize the continued existence of any species proposed to be listed under the Act or result in the destruction or adverse modification of proposed critical habitat.

We published a final rule revising the definition of destruction or adverse modification on August 27, 2019 (84 FR 44976). Destruction or adverse modification means a direct or indirect alteration that appreciably diminishes the value of critical habitat as a whole for the conservation of a listed species.

If a Federal action may affect a listed species or its critical habitat, the responsible Federal agency (action agency) must enter into consultation with us. Examples of actions that are subject to the section 7 consultation process are actions on State, Tribal,

local, or private lands that require a Federal permit (such as a permit from the U.S. Army Corps of Engineers under section 404 of the Clean Water Act (33 U.S.C. 1251 *et seq.*) or a permit from the Service under section 10 of the Act) or that involve some other Federal action (such as funding from the Federal Highway Administration, Federal Aviation Administration, or Federal Emergency Management Agency). Federal actions not affecting listed species or critical habitat—and actions on State, Tribal, local, or private lands that are not federally funded, authorized, or carried out by a Federal agency—do not require section 7 consultation.

Compliance with the requirements of section 7(a)(2) is documented through our issuance of:

(1) A concurrence letter for Federal actions that may affect, but are not likely to adversely affect, listed species or critical habitat; or

(2) A biological opinion for Federal actions that may affect, and are likely to adversely affect, listed species or critical habitat.

When we issue a biological opinion concluding that a project is likely to jeopardize the continued existence of a listed species and/or destroy or adversely modify critical habitat, we provide reasonable and prudent alternatives to the project, if any are identifiable, that would avoid the likelihood of jeopardy and/or destruction or adverse modification of critical habitat. We define “reasonable and prudent alternatives” (at 50 CFR 402.02) as alternative actions identified during consultation that:

(1) Can be implemented in a manner consistent with the intended purpose of the action,

(2) Can be implemented consistent with the scope of the Federal agency's legal authority and jurisdiction,

(3) Are economically and technologically feasible, and

(4) Would, in the Service Director's opinion, avoid the likelihood of jeopardizing the continued existence of the listed species and/or avoid the likelihood of destroying or adversely modifying critical habitat.

Reasonable and prudent alternatives can vary from slight project modifications to extensive redesign or relocation of the project. Costs associated with implementing a reasonable and prudent alternative are similarly variable.

Regulations at 50 CFR 402.16 set forth requirements for Federal agencies to reinstate formal consultation on previously reviewed actions. These requirements apply when the Federal

agency has retained discretionary involvement or control over the action (or the agency's discretionary involvement or control is authorized by law) and, subsequent to the previous consultation, when: (1) The amount or extent of taking specified in the incidental take statement is exceeded; (2) new information reveals effects of the action that may affect listed species or critical habitat in a manner or to an extent not previously considered; (3) the identified action is subsequently modified in a manner that causes an effect to the listed species or critical habitat that was not considered in the biological opinion; or (4) a new species is listed or critical habitat designated that may be affected by the identified action.

In such situations, Federal agencies sometimes may need to request reinitiation of consultation with us, but the regulations also specify some exceptions to the requirement to reinstate consultation on specific land management plans after subsequently listing a new species or designating new critical habitat. See the regulations for a description of those exceptions.

#### Application of the “Destruction or Adverse Modification” Standard

The key factor related to the destruction or adverse modification determination is whether implementation of the proposed Federal action directly or indirectly alters the designated critical habitat in a way that appreciably diminishes the value of the critical habitat as a whole for the conservation of the listed species. As discussed above, the role of critical habitat is to support physical or biological features essential to the conservation of a listed species and provide for the conservation of the species.

Section 4(b)(8) of the Act requires us to briefly evaluate and describe, in any proposed or final regulation that designates critical habitat, activities involving a Federal action that may violate section 7(a)(2) of the Act by destroying or adversely modifying such habitat, or that may be affected by such designation.

Activities that the Service may, during a consultation under section 7(a)(2) of the Act, consider likely to destroy or adversely modify the critical habitat of Tiehm's buckwheat include, but are not limited to, actions that are likely to cause large-scale habitat impacts, adversely affecting the physical and biological features at a scale and magnitude such that the designated critical habitat would no longer be able to provide for the conservation of the

species. Examples include removing corridors for pollinator movement and seed dispersal; significantly disrupting the native vegetative assemblage, seed bank, or soil composition and structure; or significantly fragmenting the landscape and decreasing the resiliency and representation of the species throughout its range (Service 2021b, p. 14). For such activities, the Service would likely require reasonable and prudent alternatives to ensure the implementation of project-specific conservation measures designed to reduce the scale and magnitude of these habitat impacts.

### Exemptions

#### *Application of Section 4(a)(3)(B)(i) of the Act*

Section 4(a)(3)(B)(i) of the Act (16 U.S.C. 1533(a)(3)(B)(i)) provides that the Secretary shall not designate as critical habitat any lands or other geographical areas owned or controlled by the Department of Defense (DoD), or designated for its use, that are subject to an integrated natural resources management plan (INRMP) prepared under section 101 of the Sikes Act (16 U.S.C. 670a), if the Secretary determines in writing that such plan provides a benefit to the species for which critical habitat is proposed for designation. No DoD lands with a completed INRMP are within the proposed critical habitat designation.

#### **Consideration of Impacts Under Section 4(b)(2) of the Act**

Section 4(b)(2) of the Act states that the Secretary shall designate and make revisions to critical habitat on the basis of the best available scientific data after taking into consideration the economic impact, national security impact, and any other relevant impact of specifying any particular area as critical habitat. The Secretary may exclude an area from designated critical habitat based on economic impacts, impacts on national security, or any other relevant impacts. In considering whether to exclude a particular area from the designation, we identify the benefits of including the area in the designation, identify the benefits of excluding the area from the designation, and evaluate whether the benefits of exclusion outweigh the benefits of inclusion. If the analysis indicates that the benefits of exclusion outweigh the benefits of inclusion, the Secretary may exercise discretion to exclude the area only if such exclusion would not result in the extinction of the species. In making the determination to exclude a particular area, the statute on its face, as well as the legislative history,

are clear that the Secretary has broad discretion regarding which factor(s) to use and how much weight to give to any factor. We describe below the process that we undertook for taking into consideration each category of impacts and our analyses of the relevant impacts.

#### *Consideration of Economic Impacts*

Section 4(b)(2) of the Act and its implementing regulations require that we consider the economic impact that may result from a designation of critical habitat. To assess the probable economic impacts of a designation, we must first evaluate specific land uses or activities and projects that may occur in the area of the critical habitat. We then must evaluate the impacts that a specific critical habitat designation may have on restricting or modifying specific land uses or activities for the benefit of the species and its habitat within the areas proposed. We then identify which conservation efforts may be the result of the species being listed under the Act versus those attributed solely to the designation of critical habitat for this particular species. The probable economic impact of a proposed critical habitat designation is analyzed by comparing scenarios both “with critical habitat” and “without critical habitat.”

The “without critical habitat” scenario represents the baseline for the analysis, which includes the existing regulatory and socio-economic burden imposed on landowners, managers, or other resource users potentially affected by the designation of critical habitat (e.g., under the Federal listing as well as other Federal, State, and local regulations). Therefore, the baseline represents the costs of all efforts attributable to the listing of the species under the Act (i.e., conservation of the species and its habitat incurred regardless of whether critical habitat is designated). The “with critical habitat” scenario describes the incremental impacts associated specifically with the designation of critical habitat for the species. The incremental conservation efforts and associated impacts would not be expected without the designation of critical habitat for the species. In other words, the incremental costs are those attributable solely to the designation of critical habitat, above and beyond the baseline costs. These are the costs we use when evaluating the benefits of inclusion and exclusion of particular areas from the final designation of critical habitat should we choose to conduct a discretionary section 4(b)(2) exclusion analysis.

For this particular designation, we developed an incremental effects

memorandum (IEM; Service 2021b, entire) considering the probable incremental economic impacts that may result from this proposed designation of critical habitat. The information contained in our IEM was then used to develop a screening analysis of the probable effects of the designation of critical habitat for Tiehm’s buckwheat (Industrial Economics Inc. (IEC) 2021, entire). We began by conducting a screening analysis of the proposed designation of critical habitat in order to focus our analysis on the key factors that are likely to result in incremental economic impacts. The purpose of the screening analysis is to filter out particular geographic areas of critical habitat that are already subject to such protections and are, therefore, unlikely to incur incremental economic impacts. In particular, the screening analysis considers baseline costs (i.e., absent critical habitat designation) and includes any probable incremental economic impacts where land and water use may already be subject to conservation plans, land management plans, best management practices, or regulations that protect the habitat area as a result of the Federal listing status of the species. Ultimately, the screening analysis allows us to focus our analysis on evaluating the specific areas or sectors that may incur probable incremental economic impacts as a result of the designation. If the proposed critical habitat designation contains any unoccupied units, the screening analysis assesses whether those units require additional management or conservation efforts that may incur incremental economic impacts. This screening analysis combined with the information contained in our IEM constitute what we consider to be our draft economic analysis (DEA) of the proposed critical habitat designation for Tiehm’s buckwheat; our DEA is summarized in the narrative below.

Executive Orders 12866 and 13563 direct Federal agencies to assess the costs and benefits of available regulatory alternatives in quantitative (to the extent feasible) and qualitative terms. Consistent with the Executive orders’ regulatory analysis requirements, our effects analysis under the Act may take into consideration impacts to both directly and indirectly affected entities, where practicable and reasonable. If sufficient data are available, we assess to the extent practicable the probable impacts to both directly and indirectly affected entities. As part of our screening analysis, we considered the types of economic activities that are likely to occur within the areas likely

affected by the critical habitat designation. In our evaluation of the probable incremental economic impacts that may result from the proposed designation of critical habitat for Tiehm's buckwheat, first we identified, in the IEM dated July 21, 2021 (Service 2021b, entire), probable incremental economic impacts associated with the following categories of activities: Mining and minerals exploration, livestock grazing, and recreation. We considered each industry or category individually. Additionally, we considered whether their activities have any Federal involvement. Critical habitat designation generally will not affect activities that do not have any Federal involvement; under the Act, designation of critical habitat only affects activities conducted, funded, permitted, or authorized by Federal agencies. Because the species is already proposed for listing, in areas where Tiehm's buckwheat is present, Federal agencies need to conference with the Service under section 7(a)(4) of the Act if it is determined that any activities they authorize, fund, or carry out are likely to jeopardize the continued existence of the species. Upon publication of this proposed critical habitat designation in the **Federal Register**, Federal agencies also need to conference with the Service under section 7(a)(4) if it is determined that any activities they authorize, fund, or carry out are likely to destroy or adversely modify the critical habitat.

In our IEM, we attempted to clarify the distinction between the effects that would result from the species being listed and those attributable to the critical habitat designation (*i.e.*, difference between the jeopardy and adverse modification standards) for Tiehm's buckwheat critical habitat. The following specific circumstances help to inform our evaluation: (1) The essential physical and biological features identified for critical habitat are the most important features essential for the life-history needs of the species, and (2) any actions that would result in sufficient adverse effect to the essential physical and biological features of critical habitat would also constitute jeopardy to Tiehm's buckwheat. The IEM outlines our rationale concerning this limited distinction between baseline conservation efforts and incremental impacts of the designation of critical habitat for Tiehm's buckwheat. This evaluation of the incremental effects has been used as the basis to evaluate the probable incremental economic impacts of this proposed designation of critical habitat.

The proposed critical habitat designation for Tiehm's buckwheat includes one critical habitat unit (Rhyolite Ridge Unit) totaling approximately 910 ac (368 ha), which was occupied by Tiehm's buckwheat at the time of proposed listing and is currently occupied. Any actions that may affect the species or its habitat would also affect critical habitat, and it is unlikely that any additional conservation efforts would be recommended to address the adverse modification standard over and above those recommended as necessary to avoid jeopardizing the continued existence of Tiehm's buckwheat. Therefore, the proposed critical habitat designation is expected to result in only administrative costs. While additional analysis will require time and resources by both the Federal action agency and the Service, it is believed that, in most circumstances, these costs would be relatively minor and administrative in nature.

This proposed critical habitat designation is expected to result in six consultations in 10 years (IEc 2021, p. 3). This additional administrative effort includes a projected estimate of five formal consultations and one programmatic consultation, which is aggregated into a given year to give a total annual incremental cost for the purpose of determining whether the rule is economically significant under Executive Order 12866 (IEc 2021, Exhibit 3, p. 12). The analysis forecasts no incremental costs associated with project modifications that would involve additional conservation efforts for Tiehm's buckwheat. The projected incremental costs for each programmatic, formal, informal, and technical assistance effort are estimated to be approximately \$5,300 (formal consultation), \$2,600 (informal consultation), \$9,800 (programmatic consultation), and \$420 (technical assistance). Analyzing the potential for adverse modification of the species' critical habitat during section 7 consultation will likely result in a total annual incremental cost of less than approximately \$37,000 (2021 dollars) in a given year for Tiehm's buckwheat (IEc 2021, Exhibits 4 and 5, p. 13); therefore, the annual administrative burden is extremely unlikely to generate costs exceeding \$100 million in a single year (*i.e.*, the threshold for an economically significant rule under Executive Order 12866).

We are soliciting data and comments from the public on the DEA discussed above, as well as on all aspects of this proposed rule and our required determinations. During the development

of a final designation, we will consider the information presented in the DEA and any additional information on economic impacts we receive during the public comment period to determine whether any specific areas should be excluded from the final critical habitat designation under the authority of section 4(b)(2) and our implementing regulations at 50 CFR 17.90. If we receive credible information regarding the existence of a meaningful economic or other relevant impact supporting a benefit of exclusion, we will conduct an exclusion analysis for the relevant area or areas. We may also exercise the discretion to evaluate any other particular areas for possible exclusion. Furthermore, when we conduct an exclusion analysis based on impacts identified by experts in, or sources with firsthand knowledge about, impacts that are outside the scope of the Service's expertise, we will give weight to those impacts consistent with the expert or firsthand information unless we have rebutting information. We may exclude an area from critical habitat if we determine that the benefits of excluding the area outweigh the benefits of including the area, provided the exclusion will not result in the extinction of this species.

#### *Consideration of National Security Impacts*

Section 4(a)(3)(B)(i) of the Act may not cover all DoD lands or areas that pose potential national-security concerns (*e.g.*, a DoD installation that is in the process of revising its INRMP for a newly listed or proposed listed species or a species previously not covered). If a particular area is not covered under section 4(a)(3)(B)(i), then national-security or homeland-security concerns are not a factor in the process of determining what areas meet the definition of "critical habitat." However, the Service must still consider impacts on national security, including homeland security, on those lands or areas not covered by section 4(a)(3)(B)(i), because section 4(b)(2) requires the Service to consider those impacts whenever it designates critical habitat. Accordingly, if DoD, Department of Homeland Security (DHS), or another Federal agency has requested exclusion based on an assertion of national-security or homeland-security concerns, or we have otherwise identified national-security or homeland-security impacts from designating particular areas as critical habitat, we generally have reason to consider excluding those areas.

However, we cannot automatically exclude requested areas. When DoD,

DHS, or another Federal agency requests exclusion from critical habitat on the basis of national-security or homeland-security impacts, we must conduct an exclusion analysis if the Federal requester provides credible information, including a reasonably specific justification of an incremental impact on national security that would result from the designation of that specific area as critical habitat. That justification could include demonstration of probable impacts, such as impacts to ongoing border-security patrols and surveillance activities, or a delay in training or facility construction, as a result of compliance with section 7(a)(2) of the Act. If the agency requesting the exclusion does not provide us with a reasonably specific justification, we will contact the agency to recommend that it provide a specific justification or clarification of its concerns relative to the probable incremental impact that could result from the designation. If we conduct an exclusion analysis because the agency provides a reasonably specific justification or because we decide to exercise the discretion to conduct an exclusion analysis, we will defer to the expert judgment of DoD, DHS, or another Federal agency as to: (1) Whether activities on its lands or waters, or its activities on other lands or waters, have national-security or homeland-security implications; (2) the importance of those implications; and (3) the degree to which the cited implications would be adversely affected in the absence of an exclusion. In that circumstance, in conducting a discretionary section 4(b)(2) exclusion analysis, we will give great weight to national-security and homeland-security concerns in analyzing the benefits of exclusion.

Under section 4(b)(2) of the Act, we also consider whether a national-security or homeland-security impact might exist on lands not owned or managed by DoD or DHS. In preparing this proposal, we have determined that the lands within the proposed designation of critical habitat for Tiehm's buckwheat are not owned or managed by DoD or DHS. Therefore, we anticipate no impact on national security or homeland security. However, if through the public comment period we receive credible information regarding impacts on national security or homeland security from designating particular areas as critical habitat, then as part of developing the final designation of critical habitat, we will conduct a discretionary exclusion analysis to determine whether to exclude those areas under authority of

section 4(b)(2) and our implementing regulations at 50 CFR 17.90.

#### *Consideration of Other Relevant Impacts*

Under section 4(b)(2) of the Act, we consider any other relevant impacts, in addition to economic impacts and impacts on national security discussed above. Other relevant impacts may include, but are not limited to, impacts to Tribes, States, local governments, public health and safety, community interests, the environment (such as increased risk of wildfire, or pest and invasive species management), Federal lands, and conservation plans, agreements, or partnerships. To identify other relevant impacts that may affect the exclusion analysis, we consider a number of factors, including whether there are permitted conservation plans covering the species in the area—such as HCPs, safe harbor agreements, or candidate conservation agreements with assurances—or whether there are non-permitted conservation agreements and partnerships that may be impaired by designation of, or exclusion from, critical habitat. In addition, we look at whether Tribal conservation plans or partnerships, Tribal resources, or government-to-government relationships of the United States with Tribal entities may be affected by the designation. We also consider any State, local, public-health, community-interest, environmental, or social impacts that might occur because of the designation.

When analyzing other relevant impacts of including a particular area in a designation of critical habitat, we weigh those impacts relative to the conservation value of the particular area. To determine the conservation value of designating a particular area, we consider a number of factors, including, but not limited to, the additional regulatory benefits that the area would receive due to the protection from destruction or adverse modification as a result of actions with a Federal nexus, the educational benefits of mapping essential habitat for recovery of the listed species, and any benefits that may result from a designation due to State or Federal laws that may apply to critical habitat.

After identifying the benefits of inclusion and the benefits of exclusion, we carefully weigh the two sides to evaluate whether the benefits of exclusion outweigh those of inclusion. If our analysis indicates that the benefits of exclusion outweigh the benefits of inclusion, we then determine whether exclusion would result in extinction of the species. If exclusion of an area from

critical habitat will result in extinction, we will not exclude it from the designation.

In the case of Tiehm's buckwheat, the benefits of critical habitat include public awareness of the presence of Tiehm's buckwheat and the importance of habitat protection, and, where a Federal nexus exists, increased habitat protection for Tiehm's buckwheat due to protection from destruction or adverse modification of critical habitat.

#### *Conservation Plans*

We evaluate the existence of a conservation plan when considering the benefits of inclusion. We consider a variety of factors, including, but not limited to, whether the plan is finalized; how it provides for the conservation of the essential physical or biological features; whether there is a reasonable expectation that the conservation management strategies and actions contained in a management plan will be implemented into the future; whether the conservation strategies in the plan are likely to be effective; and whether the plan contains a monitoring program or adaptive management to ensure that the conservation measures are effective and can be adapted in the future in response to new information.

#### *Private or Other Non-Federal Conservation Plans or Agreements and Partnerships*

We sometimes exclude specific areas from critical habitat designations based in part on the existence of private or other non-Federal conservation plans or agreements and their attendant partnerships. A conservation plan or agreement describes actions that are designed to provide for the conservation needs of a species and its habitat, and may include actions to reduce or mitigate negative effects on the species caused by activities on or adjacent to the area covered by the plan. Conservation plans or agreements can be developed by private entities with no Service involvement, or in partnership with the Service, sometimes through the permitting process under section 10 of the Act.

When we undertake a discretionary section 4(b)(2) analysis, we evaluate a variety of factors to determine how the benefits of any exclusion and the benefits of inclusion are affected by the existence of private or other non-Federal conservation plans or agreements and their attendant partnerships. The factors we consider may differ, depending on whether we are evaluating a conservation plan that involves permits under section 10 or a non-permitted plan (see 50 CFR 17.90(d)(3) and (4)).

There are no habitat conservation plans for the area in the proposed critical habitat designation for Tiehm's buckwheat.

#### *Ioneer USA Corporation (Ioneer)*

As part of the proposed Rhyolite Ridge Lithium-Boron project, Ioneer USA Corporation (Ioneer) is developing a conservation strategy for Tiehm's buckwheat to protect and preserve the continued viability of the species on a long-term basis. Currently, the conservation strategy is in the early stages (Ioneer 2020b, entire).

Ioneer has also implemented or proposed various protection measures for Tiehm's buckwheat. Ioneer funded the development of a habitat suitability model to identify additional potential habitat for Tiehm's buckwheat through field surveys (Ioneer 2020a, p. 12). In addition, a demographic monitoring program was initiated in 2019, to detect and document trends in population size, acres inhabited, size class distribution, and cover with permanent monitoring transects established in subpopulations 1, 2, 3, 4, and 6 (Ioneer 2020a, p. 16). Ioneer also funded collection of Tiehm's buckwheat seed in 2019 (Ioneer 2020a, pp. 13–14). Some of this seed was used by the University of Nevada, Reno (UNR), for a propagation trial and transplant study (Ioneer 2020a, p. 14). The remainder of this seed is in long-term storage at Rae Selling Berry Seed Bank at Portland State University (Ioneer 2020a, p. 13). As part of its proposed mining plan of operations, Tiehm's buckwheat protection plan, Ioneer also plans to avoid subpopulations 1, 2, 3, and 8 (Ioneer 2020a, p. 11), fence and place signage around subpopulations 1 and 2 (Ioneer 2020a, p. 11), and remove and salvage all remaining plants in subpopulations 4, 5, 6, and 7 and translocate them to another location (Ioneer 2020a, p. 15). However, the proposed Rhyolite Ridge Lithium-Boron project may or may not be permitted by the BLM, and these protection measures may or may not be fully implemented.

#### *Tribal Lands*

Several Executive orders, Secretarial Orders, and policies concern working with Tribes. These guidance documents generally confirm our trust responsibilities to Tribes, recognize that Tribes have sovereign authority to control Tribal lands, emphasize the importance of developing partnerships with Tribal governments, and direct the Service to consult with Tribes on a government-to-government basis. In addition, we look at the existence of Tribal conservation plans and

partnerships. In preparing this proposal, we have determined that the proposed designation of critical habitat does not include any Tribal lands or trust resources. We anticipate no impact on Tribal lands or partnerships from this proposed designation of critical habitat.

We may also consider areas not identified for inclusion or exclusion from the final critical habitat designation based on information we may receive during the public comment period. As noted above, we have requested that the entities seeking inclusion or exclusion of areas provide credible information regarding the existence of a meaningful economic or other relevant impact supporting a benefit of exclusion for that particular area (see 50 CFR 17.90). A final determination on whether the Secretary will exercise her discretion to include or exclude this area from critical habitat for Tiehm's buckwheat will be made at the time of our final determination regarding critical habitat. During the development of a final designation, we will consider any additional information we receive through the public comment period regarding other relevant impacts of the proposed designation and will determine whether any specific areas should be excluded from the final critical habitat designation under authority of section 4(b)(2) and our implementing regulations at 50 CFR 424.19.

#### **Required Determinations**

##### *Clarity of the Rule*

We are required by Executive Orders 12866 and 12988 and by the Presidential Memorandum of June 1, 1998, to write all rules in plain language. This means that each rule we publish must:

- (1) Be logically organized;
- (2) Use the active voice to address readers directly;
- (3) Use clear language rather than jargon;
- (4) Be divided into short sections and sentences; and
- (5) Use lists and tables wherever possible.

If you feel that we have not met these requirements, send us comments by one of the methods listed in **ADDRESSES**. To better help us revise the rule, your comments should be as specific as possible. For example, you should tell us the numbers of the sections or paragraphs that are unclearly written, which sections or sentences are too long, the sections where you feel lists or tables would be useful, etc.

##### *Regulatory Planning and Review (Executive Orders 12866 and 13563)*

Executive Order 12866 provides that the Office of Information and Regulatory Affairs (OIRA) in the Office of Management and Budget will review all significant rules. OIRA has determined that this rule is not significant.

Executive Order 13563 reaffirms the principles of Executive Order 12866 while calling for improvements in the nation's regulatory system to promote predictability, to reduce uncertainty, and to use the best, most innovative, and least burdensome tools for achieving regulatory ends. The executive order directs agencies to consider regulatory approaches that reduce burdens and maintain flexibility and freedom of choice for the public where these approaches are relevant, feasible, and consistent with regulatory objectives. Executive Order 13563 emphasizes further that regulations must be based on the best available science and that the rulemaking process must allow for public participation and an open exchange of ideas. We have developed this proposed rule in a manner consistent with these requirements.

##### *Regulatory Flexibility Act (5 U.S.C. 601 et seq.)*

Under the Regulatory Flexibility Act (RFA; 5 U.S.C. 601 *et seq.*), as amended by the Small Business Regulatory Enforcement Fairness Act of 1996 (SBREFA; 5 U.S.C. 801 *et seq.*), whenever an agency is required to publish a notice of rulemaking for any proposed or final rule, it must prepare and make available for public comment a regulatory flexibility analysis that describes the effects of the rule on small entities (*i.e.*, small businesses, small organizations, and small government jurisdictions). However, no regulatory flexibility analysis is required if the head of the agency certifies the rule will not have a significant economic impact on a substantial number of small entities. The SBREFA amended the RFA to require Federal agencies to provide a certification statement of the factual basis for certifying that the rule will not have a significant economic impact on a substantial number of small entities.

According to the Small Business Administration, small entities include small organizations such as independent nonprofit organizations; small governmental jurisdictions, including school boards and city and town governments that serve fewer than 50,000 residents; and small businesses (13 CFR 121.201). Small businesses include manufacturing and mining



concerns with fewer than 500 employees, wholesale trade entities with fewer than 100 employees, retail and service businesses with less than \$5 million in annual sales, general and heavy construction businesses with less than \$27.5 million in annual business, special trade contractors doing less than \$11.5 million in annual business, and agricultural businesses with annual sales less than \$750,000. To determine whether potential economic impacts to these small entities are significant, we considered the types of activities that might trigger regulatory impacts under this designation as well as types of project modifications that may result. In general, the term “significant economic impact” is meant to apply to a typical small business firm’s business operations.

Under the RFA, as amended, and as understood in light of recent court decisions, Federal agencies are required to evaluate the potential incremental impacts of rulemaking on those entities directly regulated by the rulemaking itself; in other words, the RFA does not require agencies to evaluate the potential impacts to indirectly regulated entities. The regulatory mechanism through which critical habitat protections are realized is section 7 of the Act, which requires Federal agencies, in consultation with the Service, to ensure that any action authorized, funded, or carried out by the agency is not likely to destroy or adversely modify critical habitat. Therefore, under section 7, only Federal action agencies are directly subject to the specific regulatory requirement (avoiding destruction and adverse modification) imposed by critical habitat designation. Consequently, it is our position that only Federal action agencies would be directly regulated if we adopt this proposed critical habitat designation. The RFA does not require evaluation of the potential impacts to entities not directly regulated. Moreover, Federal agencies are not small entities. Therefore, because no small entities would be directly regulated by this rulemaking, the Service certifies that, if made final as proposed, the critical habitat designation for Tiehm’s buckwheat will not have a significant economic impact on a substantial number of small entities.

In summary, we have considered whether the proposed designation would result in a significant economic impact on a substantial number of small entities. For the above reasons and based on currently available information, we certify that, if made final as proposed, the critical habitat

designation for Tiehm’s buckwheat will not have a significant economic impact on a substantial number of small business entities. Therefore, an initial regulatory flexibility analysis is not required.

*Energy Supply, Distribution, or Use—Executive Order 13211*

Executive Order 13211 (Actions Concerning Regulations That Significantly Affect Energy Supply, Distribution, or Use) requires agencies to prepare Statements of Energy Effects when undertaking certain actions. There are no operation, management, and maintenance activities of utility facilities (e.g., hydropower facilities, powerlines, pipelines) that we are aware of or that have been known to occur within the range of Tiehm’s buckwheat and its proposed critical habitat unit. If proposed in the future, these are activities that the Service consults on with Federal agencies (and their respective permittees, including utility companies) under section 7 of the Act. As discussed in the DEA, the costs associated with consultations related to occupied critical habitat would be largely administrative in nature and are not anticipated to reach \$100 million in any given year based on the anticipated annual number of consultations and associated consultation costs, which are not expected to exceed \$37,000 per year (2021 dollars) (IEc 2021, p. 13). In our economic analysis, we did not find that this proposed critical habitat designation would significantly affect energy supplies, distribution, or use. Therefore, this action is not a significant energy action, and no Statement of Energy Effects is required.

*Unfunded Mandates Reform Act (2 U.S.C. 1501 et seq.)*

In accordance with the Unfunded Mandates Reform Act (2 U.S.C. 1501 et seq.), we make the following finding:

(1) This proposed rule would not produce a Federal mandate. In general, a Federal mandate is a provision in legislation, statute, or regulation that would impose an enforceable duty upon State, local, or Tribal governments, or the private sector, and includes both “Federal intergovernmental mandates” and “Federal private sector mandates.” These terms are defined in 2 U.S.C. 658(5)–(7). “Federal intergovernmental mandate” includes a regulation that “would impose an enforceable duty upon State, local, or Tribal governments” with two exceptions. It excludes “a condition of Federal assistance.” It also excludes “a duty arising from participation in a voluntary Federal program,” unless the regulation

“relates to a then-existing Federal program under which \$500,000,000 or more is provided annually to State, local, and Tribal governments under entitlement authority,” if the provision would “increase the stringency of conditions of assistance” or “place caps upon, or otherwise decrease, the Federal Government’s responsibility to provide funding,” and the State, local, or Tribal governments “lack authority” to adjust accordingly. At the time of enactment, these entitlement programs were: Medicaid; Aid to Families with Dependent Children work programs; Child Nutrition; Food Stamps; Social Services Block Grants; Vocational Rehabilitation State Grants; Foster Care, Adoption Assistance, and Independent Living; Family Support Welfare Services; and Child Support Enforcement. “Federal private sector mandate” includes a regulation that “would impose an enforceable duty upon the private sector, except (i) a condition of Federal assistance or (ii) a duty arising from participation in a voluntary Federal program.”

The designation of critical habitat does not impose a legally binding duty on non-Federal Government entities or private parties. Under the Act, the only regulatory effect is that Federal agencies must ensure that their actions do not destroy or adversely modify critical habitat under section 7. While non-Federal entities that receive Federal funding, assistance, or permits, or that otherwise require approval or authorization from a Federal agency for an action, may be indirectly impacted by the designation of critical habitat, the legally binding duty to avoid destruction or adverse modification of critical habitat rests squarely on the Federal agency. Furthermore, to the extent that non-Federal entities are indirectly impacted because they receive Federal assistance or participate in a voluntary Federal aid program, the Unfunded Mandates Reform Act would not apply, nor would critical habitat shift the costs of the large entitlement programs listed above onto State governments.

(2) We do not believe that this rule would significantly or uniquely affect small governments because it is not anticipated to reach a Federal mandate of \$100 million in any given year; that is, it is not a “significant regulatory action” under the Unfunded Mandates Reform Act. The designation of critical habitat imposes no obligations on State or local governments. Small governments could be affected only to the extent that any programs having Federal funds, permits, or other authorized activities must ensure that

their actions will not adversely affect the critical habitat. By definition, Federal agencies are not considered small entities, although the activities they fund or permit may be proposed or carried out by small entities. Consequently, we do not believe that the proposed critical habitat designation would significantly or uniquely affect small government entities. Therefore, a Small Government Agency Plan is not required.

#### *Takings—Executive Order 12630*

In accordance with Executive Order 12630 (Government Actions and Interference with Constitutionally Protected Private Property Rights), we have analyzed the potential takings implications of designating critical habitat for Tiehm's buckwheat in a takings implications assessment. The Act does not authorize the Service to regulate private actions on private lands or confiscate private property as a result of critical habitat designation. Designation of critical habitat does not affect land ownership, or establish any closures or restrictions on use of or access to the designated areas. Furthermore, the designation of critical habitat does not affect landowner actions that do not require Federal funding or permits, nor does it preclude development of habitat conservation programs or issuance of incidental take permits to permit actions that do require Federal funding or permits to go forward. However, Federal agencies are prohibited from carrying out, funding, or authorizing actions that would destroy or adversely modify critical habitat. A takings implications assessment has been completed for the proposed designation of critical habitat for Tiehm's buckwheat, and it concludes that, if adopted, this designation of critical habitat does not pose significant takings implications for lands within or affected by the designation.

#### *Federalism—Executive Order 13132*

In accordance with Executive Order 13132 (Federalism), this proposed rule does not have significant federalism effects. A federalism summary impact statement is not required. In keeping with Department of the Interior and Department of Commerce policy, we requested information from, and coordinated development of this proposed critical habitat designation with, appropriate State resource agencies. From a federalism perspective, the designation of critical habitat directly affects only the responsibilities of Federal agencies. The Act imposes no other duties with respect to critical

habitat, either for States and local governments, or for anyone else. As a result, the proposed rule does not have substantial direct effects either on the States, or on the relationship between the Federal Government and the States, or on the distribution of powers and responsibilities among the various levels of government. The proposed designation may have some benefit to these governments because the areas that contain the features essential to the conservation of the species are more clearly defined, and the physical or biological features of the habitat necessary for the conservation of the species are specifically identified. This information does not alter where and what federally sponsored activities may occur. However, it may assist State and local governments in long-range planning because they no longer have to wait for case-by-case section 7 consultations to occur.

Where State and local governments require approval or authorization from a Federal agency for actions that may affect critical habitat, consultation under section 7(a)(2) of the Act would be required. While non-Federal entities that receive Federal funding, assistance, or permits, or that otherwise require approval or authorization from a Federal agency for an action, may be indirectly impacted by the designation of critical habitat, the legally binding duty to avoid destruction or adverse modification of critical habitat rests squarely on the Federal agency.

#### *Civil Justice Reform—Executive Order 12988*

In accordance with Executive Order 12988 (Civil Justice Reform), the Office of the Solicitor has determined that the rule would not unduly burden the judicial system and that it meets the requirements of sections 3(a) and 3(b)(2) of the order. We have proposed designating critical habitat in accordance with the provisions of the Act. To assist the public in understanding the habitat needs of the species, this proposed rule identifies the physical or biological features essential to the conservation of the species. The proposed areas of critical habitat are presented on maps, and the proposed rule provides several options for the interested public to obtain more detailed location information, if desired.

#### *Paperwork Reduction Act of 1995 (44 U.S.C. 3501 et seq.)*

This rule does not contain information collection requirements, and a submission to the Office of Management and Budget (OMB) under the Paperwork Reduction Act of 1995

(44 U.S.C. 3501 *et seq.*) is not required. We may not conduct or sponsor and you are not required to respond to a collection of information unless it displays a currently valid OMB control number.

#### *National Environmental Policy Act (42 U.S.C. 4321 et seq.)*

It is our position that, outside the jurisdiction of the U.S. Court of Appeals for the Tenth Circuit, we do not need to prepare environmental analyses pursuant to the National Environmental Policy Act (NEPA; 42 U.S.C. 4321 *et seq.*) in connection with regulations adopted pursuant to section 4(a) of the Act. We published a notice outlining our reasons for this determination in the **Federal Register** on October 25, 1983 (48 FR 49244). This position was upheld by the U.S. Court of Appeals for the Ninth Circuit (*Douglas County v. Babbitt*, 48 F.3d 1495 (9th Cir. 1995), cert. denied 516 U.S. 1042 (1996)).

#### *Government-to-Government Relationship With Tribes*

In accordance with the President's memorandum of April 29, 1994 (Government-to-Government Relations with Native American Tribal Governments; 59 FR 22951), Executive Order 13175 (Consultation and Coordination with Indian Tribal Governments), and the Department of the Interior's manual at 512 DM 2, we readily acknowledge our responsibility to communicate meaningfully with recognized Federal Tribes on a government-to-government basis. In accordance with Secretarial Order 3206 of June 5, 1997 (American Indian Tribal Rights, Federal-Tribal Trust Responsibilities, and the Endangered Species Act), we readily acknowledge our responsibilities to work directly with Tribes in developing programs for healthy ecosystems, to acknowledge that Tribal lands are not subject to the same controls as Federal public lands, to remain sensitive to Indian culture, and to make information available to Tribes. There are no Tribal lands included in this proposed designation of critical habitat.

#### **References Cited**

A complete list of references cited in this rulemaking is available on the internet at <https://www.regulations.gov> and upon request from the Reno Fish and Wildlife Office (see **FOR FURTHER INFORMATION CONTACT**).

#### **Authors**

The primary authors of this proposed rule are the staff members of the Fish and Wildlife Service's Species

Assessment Team and the Reno Fish and Wildlife Office.

#### List of Subjects in 50 CFR Part 17

Endangered and threatened species, Exports, Imports, Plants, Reporting and recordkeeping requirements, Transportation, Wildlife.

#### Proposed Regulation Promulgation

Accordingly, we propose to amend part 17, subchapter B of chapter I, title 50 of the Code of Federal Regulations, as set forth below:

#### PART 17—ENDANGERED AND THREATENED WILDLIFE AND PLANTS

■ 1. The authority citation for part 17 continues to read as follows:

**Authority:** 16 U.S.C. 1361–1407; 1531–1544; and 4201–4245, unless otherwise noted.

■ 2. Amend § 17.96, in paragraph (a), by adding an entry for “Family Polygonaceae: *Eriogonum tiehmii* (Tiehm’s buckwheat)” in alphabetical order to read as follows:

#### § 17.96 Critical habitat—plants.

(a) \* \* \*

Family Polygonaceae: *Eriogonum tiehmii* (Tiehm’s buckwheat)

(1) The critical habitat unit is depicted for Esmeralda County, Nevada, on the map in this entry.

(2) Within these areas, the physical or biological features essential to the conservation of Tiehm’s buckwheat consist of the following:

(i) *Plant community.* A plant community that supports all life stages of Tiehm’s buckwheat includes:

(A) Open to sparsely vegetated areas with low native plant cover and stature.

(B) An intact, native vegetation assemblage that can include, but is not limited to, *Atriplex confertifolia* (shadscale saltbush), *Hilaria jamesii* (James’ galleta), and *Sporobolus airoides* (alkali sacaton) to protect Tiehm’s buckwheat from nonnative, invasive plant species and provide the habitats needed by Tiehm’s buckwheat’s insect visitors and pollinators.

(C) A diversity of native plants whose blooming times overlap to provide insect visitors and pollinator species with flowers for foraging throughout the seasons and to provide nesting and egg-laying sites; appropriate nest materials; and sheltered, undisturbed habitat for hibernation and overwintering of pollinator species and insect visitors.

(ii) *Pollinators and insect visitors.*

Sufficient pollinators and insect visitors, particularly bees, wasps, beetles, and flies, are present for the species’ successful reproduction and seed production.

(iii) *Hydrology.* Hydrology that is suitable for Tiehm’s buckwheat consists of dry, open, relatively barren, upland sites subject to occasional precipitation from rain and/or snow for seed germination.

(iv) *Suitable soils.* Soils that are suitable for Tiehm’s buckwheat consist of:

(A) Light-colored, rocky soils derived from an uncommon formation of interbedded claystones, shales, tuffaceous sandstones, and limestones.

(B) Soils that are poor, with little development; lack an A horizon; and are full of broken pieces of the parent bedrock.

(C) Soils characterized by a variety of textures, and include clay soils, sandy clay loams, sandy loams, and loams.

(D) Soils with pH ranges from 7.64 to 8.76.

(E) Soils that commonly have on average boron and bicarbonates present at higher levels, and potassium, zinc, sulfur, and magnesium present at lower levels.

(3) Critical habitat does not include manmade structures (such as buildings, aqueducts, runways, roads, and other paved areas) and the land on which they are located existing within the legal boundaries on [EFFECTIVE DATE OF THE FINAL RULE].

(4) Data layers defining the map unit were created by the Service, and the critical habitat unit was then mapped using Universal Transverse Mercator Zone 11N coordinates. The map in this entry, as modified by any accompanying regulatory text, establishes the boundaries of the critical habitat designation. The coordinates or plot points or both on which the map is based are available to the public at <https://www.regulations.gov> at Docket No. FWS–R8–ES–2020–0017 and at the field office responsible for this designation. You may obtain field office location information by contacting the Service regional office, the address of which is listed at 50 CFR 2.2.

(5) Rhyolite Ridge Unit, Esmeralda County, Nevada.

(i) The Rhyolite Ridge Unit consists of approximately 910 acres (368 hectares) of occupied habitat in the Rhyolite Ridge area of the Silver Peak Range in Esmeralda County, Nevada. All lands within this unit are under Federal ownership (Bureau of Land Management).

(ii) Map of the Rhyolite Ridge Unit follows:

**BILLING CODE 4333–15–P**

Figure 1 to *Eriogonum tiehmii* (Tiehm's buckwheat) paragraph (5)(ii)

### Rhyolite Ridge Unit: Critical Habitat for Tiehm's buckwheat Esmeralda County, Nevada

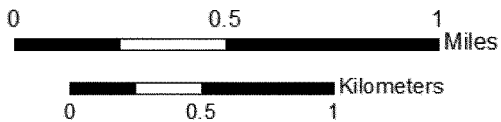
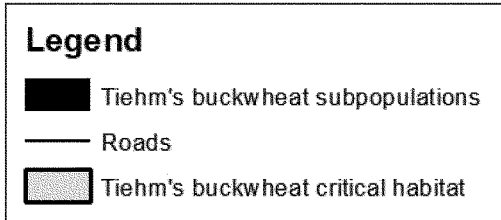
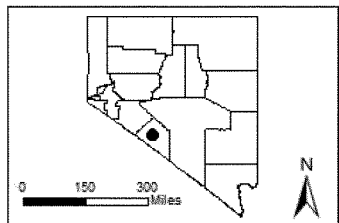
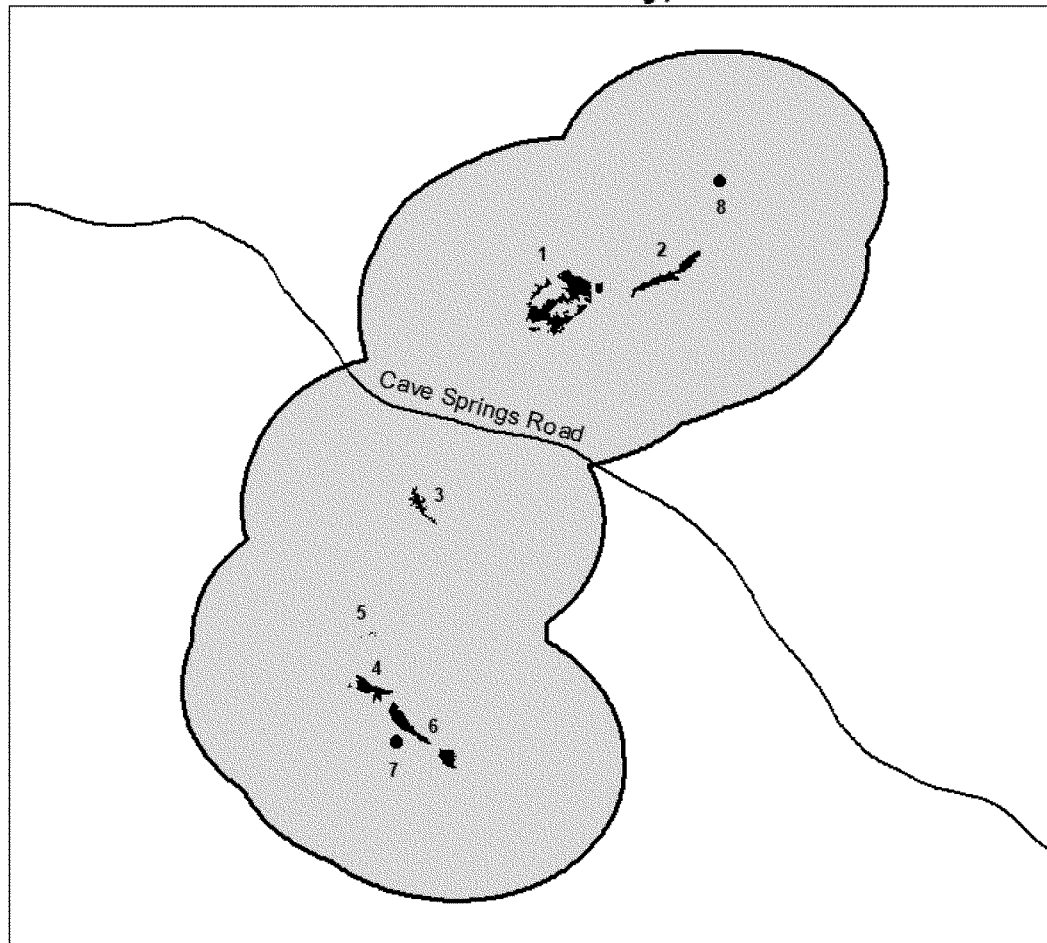

\* \* \* \* \*

**Martha Williams,**

*Principal Deputy Director, Exercising the Delegated Authority of the Director, U.S. Fish and Wildlife Service.*

[FR Doc. 2022-02298 Filed 2-2-22; 8:45 am]

BILLING CODE 4333-15-C

**DEPARTMENT OF THE INTERIOR****Fish and Wildlife Service****50 CFR Part 17**

[Docket No. FWS-R4-ES-2019-0018; FF09E22000 FXES1113090FEDR 223]

RIN 1018-BE09

**Endangered and Threatened Wildlife and Plants; Reclassification of the Red-Cockaded Woodpecker From Endangered to Threatened With a Section 4(d) Rule**

**AGENCY:** Fish and Wildlife Service, Interior.

**ACTION:** Proposed rule; revisions and reopening of comment period.

**SUMMARY:** We, the U.S. Fish and Wildlife Service (Service), announce the reopening of the comment period on our October 8, 2020, proposed rule to reclassify the red-cockaded woodpecker (*Dryobates borealis*) as a threatened species with a rule issued under section 4(d) of the Endangered Species Act of 1973 (Act), as amended. This action will allow all interested parties the opportunity to comment on the revised proposed section 4(d) rule language set forth in this document, which addresses concerns raised in the public comments we received on the October 8, 2020, proposed rule. Comments previously submitted on the proposed reclassification of the red-cockaded woodpecker and previously proposed section 4(d) rule need not be resubmitted, as they will be fully considered in preparation of the final determination.

**DATES:** The public comment period on the proposed rule that published on October 8, 2020, at 85 FR 63474, is reopened. We will accept comments received or postmarked on or before March 7, 2022. Comments submitted electronically using the Federal eRulemaking Portal (see **ADDRESSES**, below) must be received by 11:59 p.m. Eastern Time on the closing date.

**ADDRESSES:** You may submit comments by one of the following methods:

(1) *Electronically:* Go to the Federal eRulemaking Portal: <https://www.regulations.gov>. In the Search box,

enter FWS-R4-ES-2019-0018, which is the docket number for this rulemaking. Then, click on the Search button. On the resulting page, in the panel on the left side of the screen, under the Document Type heading, check the Proposed Rule box to locate this document. You may submit a comment by clicking on "Comment."

(2) *By hard copy:* Submit by U.S. mail to: Public Comments Processing, Attn: FWS-R4-ES-2019-0018, U.S. Fish and Wildlife Service, MS: PRB/3W, 5275 Leesburg Pike, Falls Church, VA 22041-3803.

We request that you send comments only by the methods described above. We will post all comments on <https://www.regulations.gov>. This generally means that we will post any personal information you provide us (see Information Requested, below, for more information).

*Availability of supporting materials:* This document and supporting materials (including the species status assessment report and references cited) are available at <https://www.regulations.gov> under Docket No. FWS-R4-ES-2019-0018 and at the Southeast Regional Office (see **FOR FURTHER INFORMATION CONTACT**).

**FOR FURTHER INFORMATION CONTACT:** Aaron Valenta, Chief, Division of Restoration and Recovery, U.S. Fish and Wildlife Service, Southeast Regional Office, 1875 Century Boulevard, Atlanta, GA 30345; telephone 404-679-4144. Persons who use a telecommunications device for the deaf (TDD) may call the Federal Relay Service at 800-877-8339.

**SUPPLEMENTARY INFORMATION:****Information Requested**

We intend that any final action resulting from the October 8, 2020, and this proposed rule will be based on the best scientific and commercial data available and be as accurate and as effective as possible. Therefore, we request comments and information from other governmental agencies, Native American Tribes, the scientific community, industry, or any other interested party concerning these proposed rules.

We particularly seek comments or information on regulations that are necessary and advisable for the conservation and management of the red-cockaded woodpecker, including whether the measures outlined in this document for the revised proposed section 4(d) rule are necessary and advisable for the conservation of the red-cockaded woodpecker. Specifically, we seek comments on:

(1) Whether the included prohibitions in the revised proposed section 4(d) rule would adequately and appropriately provide for the conservation of the red-cockaded woodpecker;

(2) Whether it is appropriate to except incidental take that results from red-cockaded woodpecker management and military training activities on Department of Defense (DoD) installations with a Service-approved integrated natural resources management plan (INRMP);

(3) Whether different or additional conditions, if any, should be applied to the exception for DoD installations in order to provide adequately for the conservation of the red-cockaded woodpecker;

(4) Whether it is appropriate to except incidental take that results from habitat management activities intended to restore or maintain red-cockaded woodpecker habitat on Federal land management agency properties;

(5) Whether different or additional conditions, if any, should be applied to the exception for Federal land management agency properties in order to provide adequately for the conservation of the red-cockaded woodpecker;

(6) Whether it is appropriate to except incidental take associated with prescribed burns and the application of herbicides on private lands when compatible with maintaining any known red-cockaded woodpecker populations;

(7) Whether different or additional conditions, if any, should be applied to the exception for prescribed burns and the application of herbicides on private lands in order to provide adequately for the conservation of the red-cockaded woodpecker;

(8) Whether it is appropriate to except incidental take that results from the installation of artificial cavity inserts and drilled cavities on public and private lands;

(9) Whether different or additional conditions, if any, should be applied to the exception for the installation of artificial cavities in order to provide adequately for the conservation of the red-cockaded woodpecker;

(10) Whether we should provide additional clarity on the minimum diameter of trees that are appropriate for selection for installation of artificial cavities and, if so, what the best available science indicates regarding a universally applicable minimum tree diameter;

(11) Whether any other forms of take should be excepted from the prohibitions in the revised proposed section 4(d) rule;

(12) Whether there are additional provisions the Service may wish to consider for the section 4(d) rule in order to conserve, recover, and manage the red-cockaded woodpecker; and

(13) Whether or how the Service could provide additional guidance or methods to streamline the implementation of the proposed section 4(d) rule for the red-cockaded woodpecker.

If you submitted comments or information on the October 8, 2020, proposed rule (85 FR 63474) during the comment period that was open from October 8, 2020, to December 7, 2020, please do not resubmit these comments. Any such comments are already part of the public record of this rulemaking proceeding, and we will fully consider them in the preparation of our final determination. Our final determination will take into consideration all written comments and any additional information we receive during both comment periods.

Please include sufficient information with your submission (such as scientific journal articles or other publications) to allow us to verify any scientific or commercial information you include.

Please note that submissions merely stating support for, or opposition to, the action under consideration without providing supporting information, although noted, will not be considered in making a determination, as section 4(b)(1)(A) of the Act directs that determinations as to whether any species is an endangered or a threatened species must be made solely on the basis of the best scientific and commercial data available.

You may submit your comments and materials concerning this proposed rule by one of the methods listed in **ADDRESSES**. We request that you send comments only by the methods described in **ADDRESSES**.

If you submit information via <https://www.regulations.gov>, your entire submission—including any personal identifying information—will be posted on the website. If your submission is made via a hardcopy that includes personal identifying information, you may request at the top of your document that we withhold this information from public review. However, we cannot guarantee that we will be able to do so. We will post all hardcopy submissions on <https://www.regulations.gov>.

Comments and materials we receive, as well as supporting documentation we used in preparing this proposed rule, will be available for public inspection on <https://www.regulations.gov>.

The final decision may differ from this revised proposed rule, based on our

review of all information we receive during this rulemaking proceeding, including both comment periods. We may change the parameters of the prohibitions or the exceptions to those prohibitions in this proposed section 4(d) rule if we conclude it is appropriate in light of comments and new information received. For example, we may establish additional exceptions to the prohibitions in the final rule if we conclude that the activities would facilitate or are compatible with the conservation and recovery of the species. We may also expand the prohibitions to include prohibiting additional activities if we conclude that those additional activities are not compatible with conservation of the species.

### Background

We will only discuss those topics directly relevant to the revisions we are proposing to the section 4(d) rule in this document. For more information on the species, its habitat, and previous Federal actions concerning the red-cockaded woodpecker, refer to the proposed rule published in the **Federal Register** on October 8, 2020 (85 FR 63474).

In our October 8, 2020, proposed rule, we proposed to reclassify the red-cockaded woodpecker as a threatened species with a section 4(d) rule that provided specific prohibitions and exceptions that we determined necessary and advisable for the conservation of the red-cockaded woodpecker. These originally proposed prohibitions included prohibiting incidental take resulting from damage or conversion of currently occupied red-cockaded woodpecker nesting and foraging habitat to other land uses that results in conditions not able to support red-cockaded woodpeckers; forest management practices in currently occupied red-cockaded woodpecker nesting and foraging habitat; operation of vehicles or mechanical equipment, the use of floodlights, activities with a human presence, other actions associated with construction and repair, or extraction activities in an active cavity tree cluster during the red-cockaded woodpecker breeding season; installation of artificial cavity inserts, drilled cavities, or cavity restrictor plates; inspecting cavity contents, including, but not limited to, use of video scopes, drop lights, or mirrors inserted into cavities; activities that render active cavity trees unusable to red-cockaded woodpeckers; and the use of insecticide or herbicide on any standing pine tree within 0.50-mile from the center of an active cavity tree cluster

of red-cockaded woodpeckers (85 FR 63498, October 8, 2020).

The species-specific exceptions in the October 8, 2020, proposed rule included excepting incidental take caused by red-cockaded woodpecker management and military training activities on DoD installations with a Service-approved INRMP; habitat restoration activities carried out in accordance with a management plan providing for red-cockaded woodpecker conservation developed in coordination with, and approved by, the Service or a State conservation agency; and operation of vehicles or mechanical equipment, the use of lights at night, or activities with a human presence in active cavity tree cluster during the red-cockaded woodpecker breeding season, under some circumstances.

We accepted comments on the October 8, 2020, proposed rule for 60 days, ending December 7, 2020. The public comments we received during that public comment period indicated significant confusion regarding the intent of the Service's proposed section 4(d) rule and how it could impact activities that may affect the red-cockaded woodpecker.

Based on these comments, we propose a revised section 4(d) rule for the red-cockaded woodpecker. We request public comments on the revised proposed section 4(d) rule set forth in this document. We will provide a more detailed response to all of the comments we have already received on the October 8, 2020, proposed rule in our final determination; however, our revisions in this document generally address the overarching comments and concerns we received from the public regarding the proposed section 4(d) rule set forth in the October 8, 2020, proposed rule.

### New Information and Revisions to Proposed 4(d) Rule

#### Background

Section 4(d) of the Act contains two sentences. The first sentence states that the Secretary of the Interior (Secretary) shall issue such regulations as she deems necessary and advisable to provide for the conservation of species listed as threatened. The U.S. Supreme Court has noted that statutory language like "necessary and advisable" demonstrates a large degree of deference to the agency (see *Webster v. Doe*, 486 U.S. 592 (1988)). Conservation is defined in the Act to mean the use of all methods and procedures which are necessary to bring any endangered species or threatened species to the point at which the measures provided pursuant to the Act are no longer

necessary. Additionally, the second sentence of section 4(d) of the Act states that the Secretary may by regulation prohibit with respect to any threatened species any act prohibited under section 9(a)(1), in the case of fish or wildlife, or 9(a)(2), in the case of plants. Thus, the combination of the two sentences of section 4(d) provides the Secretary with wide latitude of discretion to select and promulgate appropriate regulations tailored to the specific conservation needs of the threatened species. The second sentence grants particularly broad discretion to the Service when adopting the prohibitions under section 9.

The courts have recognized the extent of the Secretary's discretion under this standard to develop rules that are appropriate for the conservation of a species. For example, courts have upheld rules developed under section 4(d) as a valid exercise of agency authority where they prohibited take of threatened wildlife or included a limited taking prohibition (see *Alsea Valley Alliance v. Lautenbacher*, 2007 U.S. Dist. Lexis 60203 (D. Or. 2007); *Washington Environmental Council v. National Marine Fisheries Service*, 2002 U.S. Dist. Lexis 5432 (W.D. Wash. 2002)). Courts have also upheld section 4(d) rules that do not address all the threats a species faces (see *State of Louisiana v. Verity*, 853 F.2d 322 (5th Cir. 1988)). As noted in the legislative history when the Act was initially enacted, "once an animal is on the threatened list, the Secretary has an almost infinite number of options available to him [or her] with regard to the permitted activities for those species. [S]he may, for example, permit taking, but not importation of such species, or [s]he may choose to forbid both taking and importation but allow the transportation of such species" (H.R. Rep. No. 412, 93rd Cong., 1st Sess. 1973).

In practice, consistent with the two sentences in section 4(d), the Secretary has two mechanisms to provide for the conservation of threatened species in a section 4(d) rule. One mechanism is to promulgate prohibitions similar to those in section 9 of the Act. As discussed above, section 4(d) grants particularly broad discretion to the Service for prohibiting acts discussed in section 9. As noted in *Sweet Home Chapter of Communities for a Great Oregon v. Babbitt*, this "second sentence gives [the Service] discretion to apply any or all of the [section 9] prohibitions to threatened species without obliging it to support such actions with findings of necessity," because "[o]nly the first sentence . . . contains the 'necessary

and advisable' language and mandates formal individualized findings" (*Sweet Home Chapter of Communities for a Great Oregon v. Babbitt*, 1 F.3d 1, 8 (D.C. Cir. 1993), *modified on other grounds on reh'g*, 17 F.3d 1463 (D.C. Cir. 1994), *rev'd on other grounds*, 515 U.S. 687 (1995)).

Secondly, section 4(d) provides the Secretary discretion to issue such regulations as she deems necessary and advisable to provide for the conservation of species listed as threatened. Therefore, in addition to prohibiting relevant forms of take, section 4(d) rules can allow other forms of take by excepting this take from the prohibitions. These exceptions can encourage managers to pursue activities that benefit the species but that might result in take, especially if this take would not result in considerable detrimental effects to the species. If the Service excepts take associated with these beneficial activities in a section 4(d) rule, managers can implement these activities without fear of violating section 9 of the Act, even if take occurs.

Exercising this authority under section 4(d) of the Act, we have developed revisions to the proposed section 4(d) rule that are designed to address the red-cockaded woodpecker's specific threats and conservation needs. Although the statute does not require us to make a "necessary and advisable" finding with respect to the adoption of specific prohibitions under section 9, we find that this rule as a whole satisfies the requirement in section 4(d) of the Act to issue regulations deemed necessary and advisable to provide for the conservation of the red-cockaded woodpecker.

As the Service concluded in its October 8, 2020, proposed rule to reclassify the red-cockaded woodpecker from endangered to threatened (85 FR 63474), the red-cockaded woodpecker is likely to become in danger of extinction within the foreseeable future primarily due to threats stemming from lack of suitable habitat. Given these threats, the intent of this revised proposed section 4(d) rule is to enhance population resiliency and to make it easier to carry out the habitat and species management activities that enhance the availability of the species' key habitat and resource needs, which are outlined in the red-cockaded woodpecker's species status assessment (SSA) report (U.S. Fish and Wildlife Service (USFWS) 2020a, pp. 74–87). This means that this proposed section 4(d) rule would prohibit take to protect the species, while also providing exceptions to these take prohibitions to encourage necessary and beneficial

habitat restoration and species' management to advance recovery.

The red-cockaded woodpecker requires cavity trees, nesting habitat, and foraging habitat (USFWS 2020a, pp. 81–85). Red-cockaded woodpeckers rely on cavities for nesting and roosting (USFWS 2020a, p. 31). Old pines are required as cavity trees because cavity chambers must be completely within the heartwood to prevent pine resin in the sapwood from entering the chamber and because heartwood diameter is a function of tree age (Jackson and Jackson 1986, pp. 319–320; Clark 1993, pp. 621–626; USFWS 2020a, p. 30). In addition, old pines have a higher incidence of the heartwood decay that greatly facilitates cavity excavation (USFWS 2020a, p. 30). As we explain in the 2003 red-cockaded woodpecker recovery plan, given that the species requires these cavities to complete its life cycle, the number of suitable cavities available can limit population size (USFWS 2003, p. 20); thus, the recovery plan states, "to prevent loss of occupied territories, existing cavity trees should be protected, so that a sufficient number of suitable ones are maintained at all times" (USFWS 2003, p. 20).

Red-cockaded woodpeckers also require open pine woodlands and savannahs with large old pines for nesting and roosting (*i.e.*, nesting habitat) (USFWS 2020a, p. 30). Cavity trees, with rare exception, occur in open stands with little or no hardwood midstory and few or no overstory hardwoods (USFWS 2020a, p. 30). Suitable foraging habitat generally consists of mature pines with an open canopy, low densities of small pines, a sparse hardwood or pine midstory, few or no overstory hardwoods, and abundant native bunchgrass and forb groundcovers (USFWS 2020a, p. 39).

Additionally, the red-cockaded woodpecker is a conservation-reliant species "highly dependent on active conservation management with prescribed fire, beneficial and compatible silvicultural methods to regulate forest composition and structure, the provision of artificial cavities where natural cavities are insufficient, translocation to sustain and increase small vulnerable populations, and effective monitoring to identify limiting biological and habitat factors for management" (USFWS 2020a, p. 129). The proposed rule to downlist the red-cockaded woodpecker from endangered to threatened emphasized this conservation reliance and indicated that the future persistence of the species will require these management actions to continue (85 FR 63474; October 8, 2020). As such, in addition to providing

prohibitions necessary to protect individuals, the revised proposed section 4(d) rule provides exceptions that would maintain and restore these essential nesting and foraging resources for the species (*i.e.*, cavity trees, nesting habitat, and foraging habitat), which will advance the species' recovery and conservation.

Specifically, the exceptions in the revised proposed section 4(d) rule encourage beneficial habitat management on Federal lands, compatible prescribed burns and use of herbicides on private lands, and the provision of artificial cavities throughout the species' range. These activities provide considerable benefit to the species and its habitat by maintaining or increasing the quantity and quality of cavity trees, nesting habitat, and foraging habitat. Additionally, this revised proposed 4(d) rule retains the proposed exception for take that results from activities authorized by a permit under the Act, which includes permits we have issued or will issue under the valuable safe harbor agreement program. Together, these prohibitions and exceptions would maintain and restore essential nesting and foraging resources for the species, improving the availability of suitable habitat, and would promote continued recovery.

Additionally, one of the primary purposes of the Act is to provide a means whereby the ecosystems upon which endangered and threatened species depend may be conserved (16 U.S.C. 1531(b)); crafting a section 4(d) rule for red-cockaded woodpecker that encourages habitat management that benefits the species would also support conservation of the native pine-grass ecosystems upon which the species depends.

The provisions of this revised proposed 4(d) rule would promote conservation of the red-cockaded woodpecker by prohibiting take that can directly or indirectly impact population demographics. It would also promote conservation of the species by providing more flexibility for incidental take that may result from activities that maintain and restore requisite habitat features.

Moreover, we acknowledge and commend the accomplishments of our Federal partners, State agencies, nongovernmental organizations, and private landowners in providing conservation for the red-cockaded woodpecker for the past four decades. This intensive management has facilitated population growth since the time of listing, thereby allowing the Service to propose downlisting the species from endangered to threatened.

Private landowners' safe harbor agreements, DoD's INRMPs, U.S. Forest Service land and resource management plans (LRMPs), and National Wildlife Refuge System habitat management plans currently provide specific measures for the active management and conservation of the species throughout its range, which have aided in the recovery of the species and its habitat. Overall, the majority of red-cockaded woodpecker populations are managed under plans that address population enhancement and habitat management to sustain or increase populations and to meet the 2003 recovery plan objectives for primary core, secondary core, and essential support populations (USFWS 2003, pp. 156–159). Our revised proposed 4(d) rule does not invalidate or replace these successful programs. In fact, the revised proposed 4(d) rule would continue to encourage private landowners to participate in the safe harbor agreement program and would provide incentives for public land managers and applicable State land management agencies to continue providing specific management for the benefit of the species and its habitat.

The provisions of this revised proposed section 4(d) rule are only one of the many tools the Service can use to promote the conservation of the red-cockaded woodpecker. For example, if this 4(d) rule is finalized, private landowners and some State agencies may still pursue regulatory flexibility through existing mechanisms that currently promote the species' conservation, such as safe harbor agreements or habitat conservation plans. These effective mechanisms would continue to provide considerable assurances for landowners.

Similarly, this 4(d) rule would not change a private landowner's ability to enroll in Natural Resources Conservation Service or Partners for Fish and Wildlife conservation programs. These Federal programs provide technical and financial assistance to private landowners to support habitat management on working lands that will benefit wildlife and other natural resources in the open-pine systems of the southeastern United States. Nationwide, these programs help conserve or restore hundreds of thousands of acres of wildlife habitat every year (USFWS 2020b, p. 4). As a result of the consultations these Federal programs conduct with the Service, enrolled private landowners already receive allowances for incidental take associated with beneficial conservation practices, without having to embark on a complex permitting process; the reclassification of the red-cockaded

woodpecker and the revised proposed 4(d) rule, if finalized, would not alter these programs. We encourage private landowners to continue participating in these valuable private lands conservation programs.

Rules under 4(d) of the Act do not and cannot remove Federal agencies' section 7 consultation obligations (see "Implications for Implementation," below). While this revised proposed 4(d) rule may facilitate a streamlined consultation for beneficial habitat management projects, Federal agencies would still consult under section 7 of the Act if their actions may affect red-cockaded woodpeckers. Specifically, Federal agencies can consult with the Service regarding their project to minimize effects to the red-cockaded woodpecker and, if needed, the Service would develop a biological opinion and accompanying incidental take statement that exempts the Federal agency from the prohibitions in the 4(d) rule, for a specific amount of incidental take, while carrying out their planned project.

Finally, this revised proposed 4(d) rule would not alter or invalidate the 2003 red-cockaded woodpecker recovery plan. Recovery plans are not regulatory documents, but rather they provide a strategy to guide the conservation and recovery of the red-cockaded woodpecker. While this revised proposed 4(d) rule does not incorporate certain specific guidelines from the 2003 recovery plan (*e.g.*, survey protocols, training requirements for acquiring a section 10(a)(1)(A) permit to monitor the species), as suggested by some commenters, these provisions may still be applicable under the 4(d) rule.

This revised proposed 4(d) rule would apply only when and if we make a final determination that the red-cockaded woodpecker should be reclassified as a threatened species. Finally, if finalized, the only portion of this document that would have regulatory effect is the text presented below under Proposed Regulation Promulgation (*i.e.*, the text we propose to add as paragraph (h) of § 17.41 of title 50 of the Code of Federal Regulations (CFR) (50 CFR 17.41(h)); the explanatory text above and in *Provisions of the Revised Proposed Section 4(d) Rule* below merely clarifies the intent of these proposed amendments to the regulations.

#### *Provisions of the Revised Proposed Section 4(d) Rule*

##### Prohibitions

In the October 8, 2020, proposed downlisting rule (85 FR 63474), the Service proposed specific provisions



that prohibited incidental take associated with activities that would result in the further loss or degradation of red-cockaded woodpecker habitat, including damage to or loss of cavity trees, among other practices, to specifically protect the species' key habitat needs. However, comments submitted by the general public, Federal agencies, and the States during the public comment period on the October 8, 2020, proposed rule expressed confusion regarding these provisions. Many commenters believed the Service was prohibiting the activities it referenced in the proposed 4(d) rule. For example, commenters believed the Service was prohibiting all use of herbicides in habitat management, given the prohibition on incidental take that resulted from herbicide use. The Service's intent in the October 8, 2020, proposed rule was to prohibit incidental take that results from certain types of habitat management and land use, not to prohibit the activities themselves. However, given this confusion regarding the language in the October 8, 2020, proposed rule, this revised proposed rule describes prohibitions in a different, but more familiar, way.

Consistent with the discretion provided by section 4(d), our revisions to the proposed section 4(d) rule would provide for the conservation of the red-cockaded woodpecker by adopting the same prohibitions that apply to an endangered species under section 9 of the Act and 50 CFR 17.21. These are the same prohibitions that currently apply to the red-cockaded woodpecker while it is listed as an endangered species. Specifically, except as otherwise authorized or permitted, this revised proposed 4(d) rule would continue to prohibit: Importing or exporting red-cockaded woodpeckers; take of red-cockaded woodpeckers; possession and other acts with unlawfully taken specimens; delivering, receiving, transporting, or shipping red-cockaded woodpeckers in interstate or foreign commerce in the course of commercial activity; and selling red-cockaded woodpeckers or offering red-cockaded woodpeckers for sale in interstate or foreign commerce. As they do now, these prohibitions would apply throughout the species' range, on both public and private lands. Over the past four decades, while the species was listed as an endangered species, these prohibitions have provided an understandable, broadly accepted framework for protecting red-cockaded woodpeckers and the habitat resources upon which they depend.

Identical to the regulations that apply under endangered status, the

prohibitions in this revised proposed section 4(d) rule would prohibit all forms of take of red-cockaded woodpeckers within the United States. Under the Act, "take" means to harass, harm, pursue, hunt, shoot, wound, kill, trap, capture, or collect, or to attempt to engage in any such conduct. The Service has further defined the terms "harm" and "harass" in regulation (50 CFR 17.3). To "harm" entails an act which actually kills or injures fish or wildlife (50 CFR 17.3). Such an act may include significant habitat modification or degradation which actually kills or injures fish or wildlife by significantly impairing essential behavioral patterns, including breeding, feeding or sheltering (50 CFR 17.3). To "harass" involves an intentional or negligent act or omission which creates the likelihood of injury to wildlife by annoying it to such an extent as to significantly disrupt normal behavioral patterns which include, but are not limited to, breeding, feeding, or sheltering (50 CFR 17.3). Take can result knowingly or otherwise, by direct and indirect impacts, and intentionally or incidentally.

As discussed in the SSA report for the species, effective monitoring, research, and translocation are an important element of the active management that promotes red-cockaded woodpecker conservation and recovery. However, in this revised proposed section 4(d) rule, we propose to prohibit all forms of take, which would include capturing, handling, and similar activities. Such activities include, but are not limited to, translocation, banding, collecting tissue samples, and research involving capturing and handling red-cockaded woodpeckers. While these activities are essential to conservation and recovery of the species, there are proper techniques to capturing and handling birds that require training and experience. Improper capture, banding, or handling can cause injury or even result in death of red-cockaded woodpeckers. Therefore, to assure these activities continue to be conducted correctly by properly trained personnel, the proposed section 4(d) rule would continue to prohibit take associated with translocation, banding, research, and other activities that involve capture or handling of red-cockaded woodpeckers; however, take that results from these activities could still be allowed under a section 10(a)(1)(A) permit.

In essence, this rule would prohibit take under all circumstances, unless otherwise excepted in the section 4(d) rule (discussed below), authorized by a permit under the Act (e.g., section

10(a)(1)(A) permit issued for a safe harbor agreement, section 10(a)(1)(B) permit issued for a habitat conservation plan), or exempted through section 7 consultation (including the consultations that cover landowners enrolled in Natural Resources Conservation Service or Partners for Fish and Wildlife conservation programs). Because the prohibitions in this proposed rule exactly match those that currently apply under endangered status, if managers (e.g., landowners, Federal agencies, utility companies) are currently carrying out compatible land use activities without resulting in take of the species, the provisions in this proposed rule would not affect their ability to continue conducting those activities; this 4(d) rule also would not alter Federal agencies' current and continued obligation to conduct necessary section 7 consultation on these activities.

Prohibiting all forms of take on both public and private lands will provide clear measures necessary and advisable to ensure the species continues to maintain or improve its demographics. Regulating both intentional and incidental take would help preserve the species' remaining populations and decrease synergistic, negative effects from other stressors, while allowing beneficial activities that do not result in take to continue to occur. The Service seeks comments on these prohibitions (see Information Requested, above).

#### Exceptions

The revised proposed section 4(d) rule would also provide for the conservation of the species by promulgating exceptions to the prohibitions discussed above; these exceptions would allow for routine law enforcement activities, for defense of life, to aid sick or injured birds, and for incidental take associated with the active habitat management this species uniquely requires. These exceptions would promote the maintenance and restoration of the habitat resources (cavity trees, nesting habitat, and foraging habitat) crucial to red-cockaded woodpecker recovery and conservation.

At the outset, the revised proposed section 4(d) rule outlines several standard exceptions to the prohibitions that are identical to exceptions that currently apply to the red-cockaded woodpecker and other endangered species. First, we propose to except certain actions that may be otherwise prohibited by this rule but that are authorized by permits under 50 CFR 17.32. Currently, activities that are prohibited by 50 CFR 17.21, which applies to endangered species, may be

permitted by permits issued under 50 CFR 17.22 for the red-cockaded woodpecker. Accordingly, the inclusion of this provision referencing 50 CFR 17.32 does not result in a change from the status quo. This means that if a manager has received or receives a permit for a particular activity (e.g., a section 10(a)(1)(A) permit for monitoring red-cockaded woodpeckers; a permit issued for a safe harbor agreement or habitat conservation plan), any take that occurs as a result of activities covered by this permit would remain exempted from the aforementioned prohibitions on take; in other words, the manager would not be liable for any take for which they already have a permit, as long as they continue to comply with the stipulations in the permit. This exception also applies to the permits that private landowners or some State agencies already hold as a result of a safe harbor agreement or habitat conservation plan. This revised proposed section 4(d) rule would not invalidate any part of a landowner's existing safe harbor agreement, habitat conservation plan, or permit. We encourage landowners to continue operating within the parameters of their safe harbor agreement, habitat conservation plan, and associated permits. As long as landowners continue to comply with the provisions of these permits, any take that occurs as a result of covered activities would be exempted from the prohibitions on take in this rule.

Furthermore, the Service encourages landowners to continue to enroll in the safe harbor agreement program. Exactly like the regulatory regime that applies while the species is listed as endangered, any new permits issued under the authority of the safe harbor agreement program would provide landowners with additional management flexibility and exemption from some of the take prohibitions in this proposed rule. Safe harbor agreements are partnerships between landowners and the Service or between the State and the Service involving voluntary agreements under which the property owners receive formal regulatory assurances from the Service regarding their management responsibilities in return for contributions to benefit the listed species.

For the red-cockaded woodpecker, this includes voluntary commitments by landowners to maintain and enhance red-cockaded woodpecker habitat to support baseline active clusters, which is the number of clusters at the time of enrollment, and to bolster their

populations with additional above-baseline active clusters that emerge in response to beneficial management. Beneficial management includes the maintenance and enhancement of existing cavity trees and foraging habitat through activities such as prescribed fire, mid-story thinning, seasonal limitations for timber harvesting, and management of pine stands to provide suitable foraging habitat and cavity trees. Permits issued under safe harbor agreements allow enrolled landowners to return their properties to "baseline" conditions at any time. Since its inception in the 1990s, the safe harbor program has successfully promoted the recovery of red-cockaded woodpeckers; due to the concerted efforts of private landowners enrolled in the program, the number of red-cockaded clusters on private lands has increased. As described in the proposed downlisting rule (85 FR 63474; October 8, 2020), 12 populations with 342 active clusters reside entirely on private lands, of which 10 populations with 295 active clusters are managed by landowners enrolled in the safe harbor agreement program. There currently are 241 active above-baseline clusters in the program. This revised proposed section 4(d) rule would not alter this valuable program or the permits associated with it.

Second, we propose to incorporate standard exceptions that currently apply to the red-cockaded woodpecker and endangered species, including exceptions that allow take in defense of life; allow take by an employee of the Service, Federal land management agency, or State conservation agency to aid sick or injured red-cockaded woodpeckers, dispose of dead specimens, or salvage dead specimens for scientific research; and allow individuals to take the species if they have a valid migratory bird rehabilitation permit if such action is necessary to aid a sick, injured, or orphaned listed migratory bird. We also propose a standard regulatory exception to allow Federal and State law enforcement officers to possess, deliver, carry, transport or ship individuals taken in violation of the Act as necessary in performing their official duties and that allow those with a valid migratory bird rehabilitation permit to possess or transport a listed migratory bird species. All of these standard exceptions currently apply while the species is listed as endangered, and they would continue to apply if we finalize the reclassification of red-cockaded woodpeckers to a threatened species with this revised proposed 4(d) rule.

Next, we propose to incorporate an exception that does not currently apply

while the woodpecker is listed as endangered. This exception from 50 CFR 17.31(b) allows employees or agents of the Service or State conservation agencies operating under a cooperative agreement with the Service in accordance with section 6(c) of the Act to take red-cockaded woodpeckers in order to carry out conservation programs for the species. The Service can only apply the exception in 50 CFR 17.31(b) to take prohibitions for threatened species. The Service recognizes the special and unique relationship with our State conservation agency partners in contributing to conservation of listed species. States solely own and manage lands occupied by at least 31 demographic populations and oversee State-wide safe harbor agreements that have enrolled 459 non-Federal landowners covering approximately 2.5 million acres (85 FR 63474; October 8, 2020).

State agencies also often possess scientific data and valuable expertise on the status and distribution of endangered, threatened, and candidate species of wildlife and plants. State agencies, because of their authorities and their close working relationships with local governments and landowners, are in a unique position to assist the Service in implementing all aspects of the Act. In this regard, section 6 of the Act provides that the Service shall cooperate to the maximum extent practicable with the States in carrying out programs authorized by the Act. Therefore, any qualified employee or agent of a State conservation agency that is a party to a cooperative agreement with the Service in accordance with section 6(c) of the Act, who is designated by his or her agency for such purposes, would be able to conduct activities designed to conserve the red-cockaded woodpecker that may result in otherwise prohibited take without additional authorization (i.e., without a permit). Most State conservation agencies within the range of red-cockaded woodpeckers have already worked with the Service to develop valid cooperative agreements under section 6(c) of the Act that include conservation programs for red-cockaded woodpeckers.

This exception is very similar to an exception that currently applies while the woodpecker is listed as endangered (the exception under 50 CFR 17.21(c)(5)). While the exception in 50 CFR 17.31(b) is similar to the exception that currently applies while the species is listed as endangered (50 CFR 17.21(c)(5)), it does not provide the same limitations on take associated with carrying out conservation programs in

States' cooperative agreements. State agencies may also enroll in the safe harbor program to receive permits that allow for certain types of take, if they are not otherwise covered by a cooperative agreement or otherwise prohibited. The Service seeks comments on the inclusion of this exception (see Information Requested, above).

Finally, unlike the regulations that apply to the species under endangered status, we propose additional exceptions to the take prohibitions in this revised proposed 4(d) rule that would facilitate continued and increased implementation of beneficial management practices that contribute to the conservation of the species. As discussed above, active management targeted at maintaining and restoring red-cockaded woodpecker populations and habitat is essential to the continued recovery of the species. The analyses in the red-cockaded woodpecker SSA report illustrate that it could take "many decades . . . to attain a desired future ecosystem condition in which red-cockaded woodpeckers are no longer dependent on artificial cavities and related special treatments. Without adequate species-level management, in contrast to ecosystem management alone, very little increase in the number of moderately to very highly resilient populations can be expected, and small populations of low or very low resilience are unlikely to persist" (USFWS 2020a, p. 12). The species-specific exceptions in this revised proposed section 4(d) rule aim to facilitate management that would protect and enhance red-cockaded woodpecker populations.

Conservation of red-cockaded woodpeckers as a species depends primarily on the conservation of populations on Federal properties (e.g., National forests, DoD installations) for several reasons. First, the vast majority of red-cockaded woodpeckers in existence today are on Federal lands (USFWS 2020a, pp. 106–108; see Table 7 in USFWS 2003, p. 137). Second, Federal properties contain most of the land that can reasonably be viewed as potential habitat for red-cockaded woodpeckers (USFWS 1985, p. 133). Third, existing Federal statutes, especially the Act, require that Federal agencies conserve listed species and maintain biodiversity within their lands. Section 2(c)(1) of the Act declares that it is the policy of Congress that all Federal departments and agencies shall seek to conserve endangered species and threatened species (16 U.S.C. 1531(c)(1)); the Act defines conservation as the use of all methods and procedures necessary to bring an

endangered species or threatened species to the point at which the measures provided pursuant to the Act are no longer necessary (16 U.S.C. 1532(3)). Private landowners, in contrast, can contribute substantially to conservation, but such contributions above complying with the statutory prohibitions (e.g., direct harm) are voluntary. For those private landowners that wish to increase the size of their population, we strongly encourage them to aim to achieve the recovery standard in the 2003 recovery plan or join the safe harbor program (USFWS 2003, pp. 188–189).

Therefore, the species-specific exceptions in this revised proposed 4(d) rule address private lands and Federal properties differently for three reasons. First, these entities have differing recovery responsibilities. Second, the Service would retain additional involvement in Federal agencies' habitat management activities as a result of section 7 consultation obligations. Third, there are other flexible programs that permit take that are already available to some State conservation agencies and private landowners (e.g., permits issued from safe harbor agreements and habitat conservation plans, Partners for Fish and Wildlife program, Natural Resources Conservation Service private landowner programs).

First, we propose an exception to the take prohibitions to allow incidental take on DoD installations that occurs as a result of implementing red-cockaded woodpecker habitat management and military training activities detailed in Service-approved INRMPS. In this proposal, we define habitat management activities as activities intended to maintain or improve the quality and/or quantity of red-cockaded woodpecker habitat, including, but not limited to, prescribed burning; using herbicides and equipment to reduce midstory encroachment, thin overstocked pine stands, promote an open canopy pine system, and promote herbaceous groundcover; converting loblolly, slash, or other planted pines to more fire-tolerant native pines such as longleaf pine; planting and seeding native, site-appropriate pines and groundcover species; and regenerating areas of older pine forest, or any overrepresented age class, to increase and maintain sustainable current and future habitat.

Within the range of the species, most DoD Army, Air Force, and Marine Corps installations have red-cockaded woodpecker management plans and guidelines incorporated into their Service-approved INRMPS to minimize the adverse effects of the military

training activities outlined in INRMPS and to achieve red-cockaded woodpecker recovery objectives. These plans and guidelines all contain an "Endangered Species Management Component" (ESMC) for red-cockaded woodpecker conservation, which includes population size objectives, management actions to achieve conservation goals, monitoring and reporting, and specific training activities that are allowed or restricted within clusters and near cavity trees. Under the Sikes Act (16 U.S.C. 670 *et seq.*), the Service is required to review and approve INRMPS, when they are revised, at least every 5 years, and participate in annual reviews. In addition to this review and approval under the Sikes Act, the Service conducts section 7 consultation under the Act on INRMPS and ESMCs to ensure DoD installations' activities are not likely to jeopardize the continued existence of any listed species, including red-cockaded woodpeckers. If this revised proposed section 4(d) rule is finalized, DoD installations would still need to comply with the Sikes Act requirement to obtain Service approval of INRMPS and would still need to fulfill their section 7 obligations under the Act, including tracking and reporting amounts of incidental take that occur as a result of activities outlined in the INRMP (see "Implications for Implementation," below, for more detail on section 7 processes under section 4(d) rules).

In addition to excepting incidental take that results from red-cockaded woodpecker habitat management activities in INRMPS, this revised proposed section 4(d) rule would except incidental take associated with routine military training activities that are included in a Service-approved INRMP. The military training activities that DoD installations include in their INRMPS have been specifically designed to minimize incidental take of listed species, including red-cockaded woodpeckers. The DoD uses long-established guidelines (e.g., Management Guidelines for the Red-cockaded Woodpecker on Army Installations (U.S. Army 1996, entire)) to inform minimization measures that reduce incidental take associated with military training. Moreover, the DoD conducts section 7 consultation with the Service on the content of their INRMPS to ensure these military training activities will not jeopardize the species. Any incidental take resulting from new proposed training or construction activities that are not incorporated into a Service-approved

INRMP would not be excepted under this proposed rule, but could be exempted through an incidental take statement associated with a biological opinion resulting from a separate section 7 consultation under the Act. In other words, if a military installation's activities do not fall within the exceptions in this proposed 4(d) rule (*i.e.*, they are not incorporated in a Service-approved INRMP) or are not otherwise covered in an existing section 7 biological opinion, incidental take that results from those activities could still be exempted from the prohibitions in this proposed 4(d) rule via a new biological opinion's incidental take statement, as long as the activities will not jeopardize the continued existence of the species.

To further ensure the DoD continues to monitor their red-cockaded woodpecker populations and habitats, the provisions in the revised proposed section 4(d) rule would require each installation to share an annual property report regarding their red-cockaded woodpecker populations. This annual property report could include the property's recovery goal; the number of active, inactive, and recruitment clusters; information on habitat quality; and the number of artificial cavities the property installed. All military installations with red-cockaded woodpecker populations currently provide such a report to the Service, and we expect this to continue if we downlist the species. This monitoring could inform adaptive management and course corrections during annual INRMP reviews.

As a result of existing conservation programs under Service-approved INRMPs, red-cockaded woodpecker populations have increased on all DoD installations. In fact, Fort Bragg, Fort Stewart, Eglin Air Force Base, Fort Benning, and Camp Blanding all have achieved or surpassed their 2003 red-cockaded woodpecker recovery plan population size objectives and are expected to continue to manage towards larger populations (USFWS 2003, pp. xiii–xx, 212–213). Active and beneficial red-cockaded woodpecker management to increase population sizes on DoD installations has been an essential component of sustaining the species, and it can balance the effects of military training.

Some comments we received on the October 8, 2020, proposed downlisting rule (85 FR 63474) raised concerns this exception for Service-approved INRMPs could be too open-ended to be sufficiently protective of the species. However, given the close, formal involvement the Service has in

reviewing and approving INRMPs under the Sikes Act, the species-specific beneficial management prescriptions that DoD installations must incorporate into the ESMCs of these plans, the monitoring that the DoD installations must conduct, and the section 7 consultation that would still occur for these plans to ensure conservation activities do not jeopardize the species, we find that the management resulting from INRMPs would continue to advance the conservation of the species, even if incidental take occurs. Therefore, this revised proposed section 4(d) rule would except incidental take resulting from red-cockaded woodpecker habitat management and military training activities on DoD installations carried out in accordance with a Service-approved INRMP. The Service seeks comments on this exception (see Information Requested, above).

Second, we propose an exception to take prohibitions to allow incidental take that results from habitat management activities intended to restore or maintain red-cockaded woodpecker habitat on Federal land management agency properties; as noted earlier, we define "habitat management activities" for the purposes of the revised proposed 4(d) rule (see Proposed Regulation Promulgation, below). We provide this exception separately from the aforementioned exception for DoD properties to account for the fact that the Sikes Act requires a different level of Service involvement in the development of INRMPs and provides different standards for content in INRMPs than other Federal natural resource management planning processes.

In order to benefit from this exception, Federal land management agencies must detail these planned activities in a Federal habitat management plan that includes a red-cockaded woodpecker management component, which addresses factors including, but not limited to, the red-cockaded woodpecker population size objective and the habitat management necessary to sustain, restore, or increase foraging habitat, nesting habitat, and cavity trees to attain population size objectives. Suitable management plans may be stand-alone documents or may be step-down plans with red-cockaded woodpecker-specific management components that implement more general plans (*e.g.*, the habitat management plans that implement the National Wildlife Refuge System's comprehensive conservation plans and red-cockaded woodpecker-specific amendments to LRMPs). In addition to

describing these habitat management activities in a Federal habitat management plan, Federal land management agencies must also incorporate appropriate conservation measures to minimize or avoid adverse effects of these habitat management activities on red-cockaded woodpecker foraging habitat, on clusters, and on the species' roosting and nesting behavior to the maximum extent practicable; Federal agencies may identify these avoidance and minimization measures in these habitat management plans or in documentation associated with the section 7 consultation process. The inclusion of "clusters" in this provision would ensure Federal land managers are adequately protecting nesting habitat and cavity trees, in addition to foraging habitat, while executing their planned beneficial habitat management activities. The Service expects the red-cockaded woodpecker components of these Federal management plans to allow for adaptive management and frequent re-evaluation of appropriate conservation activities and minimization measures.

Moreover, to further ensure Federal land management agencies continue to monitor their red-cockaded woodpecker populations and habitats, the provisions in the revised proposed section 4(d) rule would require each Federal property to share an annual property report with the Service regarding their red-cockaded woodpecker populations. This annual property report could include the property's recovery goal; the number of active, inactive, and recruitment clusters; information on habitat quality; and the number of artificial cavities the property installed. All Federal properties with red-cockaded woodpecker populations currently provide such a report to the Service, and we expect this to continue if we downlist the species. The reporting Federal agencies provide as part of section 7 consultations would also qualify as this annual property report.

As a result of this proposed provision in the section 4(d) rule, we would, under certain conditions, except incidental take associated with habitat management activities on Federal lands that have short-term adverse effects to red-cockaded woodpeckers, but that are intended to provide for improved habitat quality and quantity in the long term, with coinciding increases in numbers of red-cockaded woodpeckers, if these activities are detailed in a management plan that can adequately address site-specific considerations. Current and future red-cockaded woodpecker habitat conditions that require such restoration can vary

significantly among sites and properties, to the extent that it would be extremely difficult to prescribe a universal condition by which this exception would apply. Therefore, in this section 4(d) rule, we propose that incidental take associated with these activities would be excepted, as long as the activities are intended to restore and maintain red-cockaded woodpecker habitat and are detailed in a Federal agency habitat management plan. These management plans can strategically and accurately assess the site-specific conditions. According to the revised proposed 4(d) rule, Federal agencies must also incorporate appropriate conservation measures to minimize the adverse effects of these activities on red-cockaded woodpecker foraging habitat, on clusters, and on the species' roosting and nesting behavior. Because Federal agencies will still need to complete section 7 consultation, as appropriate, on these habitat management plans or projects, the Service would have the opportunity to review these restoration projects and provide input on how to minimize impacts to the species.

Again, the Service seeks to encourage comprehensive, proactive management that results in red-cockaded woodpecker population growth and stability since, according to the 2003 recovery plan, "development and maintenance of viable recovery populations is dependent on restoration and maintenance of appropriate habitat" (USFWS 2003, p. 32). Continued conservation activities and beneficial land management are necessary to address the threats of habitat degradation and fragmentation, and it is the intent of this revised proposed rule to encourage these activities.

Most Federal properties within the range of the red-cockaded woodpecker already have management plans that detail habitat management activities specifically intended to restore or maintain red-cockaded woodpecker habitat; this exception would not require these agencies to rewrite these management plans or to reinitiate section 7 consultation on these plans or on relevant projects. Moreover, because this revised proposed section 4(d) rule would not remove or alter the obligation of Federal agencies to complete section 7 consultation on their management plans, the Service would have the opportunity to review any major changes to these site-specific plans to ensure the Federal agency's habitat management activities are not likely to jeopardize the continued existence of any listed species, including the red-cockaded woodpecker. As part of this section 7 process, the Service would

produce an incidental take statement for the estimated amount of take reasonably likely to occur as a result of the management plan's activities, even though that take would be excepted under the section 4(d) rule.

Additionally, Federal agencies would still track all incidental take, even if it is excepted under this provision. If they exceed the amount of take in this incidental take statement as a result of carrying out the activities in their management plan, they would need to reinitiate consultation (see "Implications for Implementation," below, for more detail on section 7 processes under section 4(d) rules).

This provision would not except take that results from habitat management or other activities that provide no benefit to red-cockaded woodpecker recovery, even if these activities are also described in the Federal management plan; however, incidental take from such activities could still be exempted through an incidental take statement associated with a biological opinion resulting from section 7 consultation under the Act. In other words, if a Federal land management agency's activities cannot comply with the exceptions in this 4(d) rule, incidental take that results from those activities could still be exempted from the prohibitions in this 4(d) rule via a project-specific section 7 consultation, as long as the activities will not jeopardize the continued existence of the species. Finally, because the prohibitions in this revised proposed section 4(d) rule match those that currently apply under endangered status, if Federal agencies are currently conducting management activities without resulting in take of red-cockaded woodpeckers, this rule would not affect their ability to continue conducting those activities, independent of this exception.

In short, if incidental take of red-cockaded woodpeckers occurs as a result of Federal land management agencies carrying out habitat management activities, as defined in the revised proposed rule, this take would not be prohibited, as long as: (1) The habitat management activities were implemented specifically to restore or maintain red-cockaded woodpecker habitat; (2) the Federal agency details these habitat management activities in a habitat management plan; (3) the Federal agency incorporates appropriate conservation measures to minimize or avoid adverse effects of these habitat management activities on red-cockaded woodpecker foraging habitat, on clusters, and on the species' roosting and nesting behavior to the maximum

extent practicable; and (4) the Federal agency provides annual reporting to the Service. The Service seeks comments on this exception (see Information Requested, above).

Third, we include an exception to encourage private landowners who are not enrolled in the safe harbor agreement program to carry out specific compatible forest management activities (namely, prescribed burns and application of herbicides), given the importance of these forest management tools for red-cockaded woodpecker recovery (USFWS 2020a, p. 129). This provision would not change the measures in any existing safe harbor agreements or habitat conservation plans.

While Federal lands bear additional responsibility when it comes to achieving the recovery goals for red-cockaded woodpeckers, private lands still play an important role in the conservation of the species. They provide for connectivity between populations, which boosts resiliency, and support additional red-cockaded woodpecker clusters to enhance redundancy and representation of the species. This revised proposed section 4(d) rule would continue to encourage voluntary red-cockaded woodpecker conservation on private lands through the successful safe harbor agreement program.

The proposed exception would further support compatible forest management on private lands, while continuing to maintain existing populations and would be especially relevant for landowners that do not currently participate in the safe harbor agreement program. This exception would except incidental take caused by application of prescribed burns or herbicides on private lands when compatible with maintaining any known red-cockaded woodpecker populations, provided that the landowner, or their representative: (1) Follows applicable best management practices for prescribed burns and applicable Federal and State laws; (2) applies herbicides in a manner consistent with applicable best management practices and applicable Federal and State laws, including Environmental Protection Agency label restrictions and herbicide application guidelines as prescribed by manufacturers; and (3) applies prescribed burns and herbicides in a manner that minimizes or avoids adverse effects to known active clusters and red-cockaded woodpecker roosting and nesting behavior to the maximum extent practicable.

The first condition on this provision requires landowners to follow applicable best management practices for prescribed burns. States and counties within the range of red-cockaded woodpecker provide guidance documents with these best management practices to ensure practitioners safely apply prescribed burns in a way that minimizes impacts to communities, riparian ecosystems, forest roads, and vegetation (e.g., North Carolina Forestry Best Management Practices Manual; Recommended Forestry Best Management Practices for Louisiana).

The third condition on this provision calls for private landowners to incorporate reasonable preventative measures to reduce any direct adverse effects of these activities on red-cockaded woodpeckers they already know to roost or nest on their property to the maximum extent practicable, increasing the net benefit that prescribed burns and herbicide application can provide to red-cockaded woodpecker habitat and clusters. However, it does not require these private landowners to survey for new clusters prior to carrying out a burn or using herbicides, nor does it require them to follow particular preventative measures the Service prescribes, although the methods the Service outlines for cavity tree protection in its red-cockaded woodpecker recovery plan can provide a helpful resource to landowners when identifying practical ways to minimize adverse effects (USFWS 2003, pp. 201–205). Thus, this measure asks that landowners responsibly apply prescribed burns and herbicides, without being unreasonably prohibitive on landowners' compatible or beneficial activities.

This provision would also only be relevant in situations where take might occur as a result of a prescribed burn or the application of herbicides. For example, if a landowner does not currently have any red-cockaded woodpecker cavity trees, clusters, or foraging woodpeckers on their property, then it is not possible for these activities to result in incidental take. Thus, this landowner can proceed with prescribed burns or the use of herbicides without the possibility of violating the take prohibitions in the section 4(d) rule, because such activities would not result in take. It is only when a prescribed burn or the use of herbicides could result in incidental take of red-cockaded woodpeckers that private landowners may wish to take advantage of this exception by following best management practices and conducting activities in a manner that minimizes or avoids adverse effects to known active

clusters and red-cockaded woodpecker roosting and nesting behavior to the maximum extent practicable. If a private landowner follows these best management practices and incorporates reasonable preventative measures while conducting prescribed burns and applying herbicides, while incidental take is unlikely, if it were to occur, the landowner would not be liable for such take under this proposed rule.

This provision would only except incidental take associated with prescribed burns or the use of herbicides when the use of these management practices are compatible with maintaining any known red-cockaded woodpecker populations on their property; in other words, if a private landowner wishes to pursue a prescribed burn that could impair red-cockaded woodpecker population dynamics in the long term, this exception would not cover any incidental take that results from that burn, even if the landowner follows relevant best management practices.

Finally, if landowners are already enrolled in the safe harbor program, this exception would not provide any additional flexibility; the permits associated with safe harbor agreements authorize take associated with prescribed burns, herbicide use, and other activities, as long as landowners follow the stipulations in their safe harbor agreement and do not decrease the number of red-cockaded woodpecker clusters below their baseline.

The Service's intent for this provision is to provide a simple means by which to encourage private landowners to pursue certain types of voluntary forest management activities (i.e., prescribed burns and herbicide application) in a way that reduces impacts to the species but also removes any potential barriers to the implementation of this beneficial forest management, such as fear of prosecution for take. Collaboration with partners in the forestry industry and their voluntary conservation and restoration of red-cockaded woodpecker habitat has helped advance red-cockaded woodpecker recovery to the point of downlisting; this provision would continue to encourage this compatible or beneficial management. We also continue to encourage private landowners to participate in existing valuable conservation programs that promote forest management that benefits red-cockaded woodpeckers and provide take allowances for participating landowners through other means (e.g., permits issued as part of the safe harbor program or habitat conservation plans, Partners for Fish

and Wildlife and Natural Resources Conservation Service private landowner programs, and the associated section 7 consultations these Federal programs conduct with the Service that provide allowances for incidental take associated with beneficial conservation practices). The Service seeks comment on this exception (see Information Requested, above).

Finally, the proposed rule would except incidental take that occurs as a result of the installation of artificial cavities, as long as individuals conducting the installation have completed training, have achieved a certain level of proficiency as detailed below, and are following appropriate guidelines. As described above, maintaining an adequate number of suitable cavities in each woodpecker cluster is fundamental to the conservation of the species. Loss of natural cavity trees was a major factor in the species' decline, and availability of natural cavity trees currently limits many populations. Until a sufficient number of large, old pines becomes widely available, installation and maintenance of artificial cavities is an essential management tool to sustain populations and bring about population increases, and the Service continues to encourage the installation of artificial cavities. However, we also acknowledge that there are proper techniques to install cavity inserts, drill cavities, or install cavity restrictor plates, and these techniques require training and experience. Improperly installed artificial cavities can cause injury or even result in death of red-cockaded woodpeckers attempting to roost or nest in them. Currently, because the species is listed as endangered, individuals must seek a section 10(a)(1)(A) permit to install artificial cavity inserts, drilled cavities, or cavity restrictor plates.

However, we recognize that many of our partners have training and extensive experience in installing artificial cavities. Moreover, given the essential nature of artificial cavity installation for the continued conservation of the species, we find it is necessary and advisable for the section 4(d) rule to remove any potential hurdles to the efficient and effective provisioning and maintenance of artificial cavities. We, therefore, provide an exception to take prohibitions in this revised proposed rule for the installation, maintenance, and replacement of artificial cavity inserts and drilled cavities on public and private lands. However, this exception would only apply if the individual conducting the installation has either held a valid Service permit for that purpose and has continued to

install, maintain, and replace cavities since the expiration of their permit or has completed a period of apprenticeship under the direction of a person that has been involved in cavity installation for at least 3 years (the trainer).

In order to complete their training, under the direct supervision of the trainer, the apprentice must install at least 10 drilled cavities, if they plan to install drilled cavities, or 10 inserts, if they plan to install inserts, and learn the proper maintenance and inspection procedures for cavities and restrictor plates. After the apprentice has completed their training, the trainer must provide a letter to the apprentice and to the U.S. Fish and Wildlife Service Regional red-cockaded woodpecker recovery coordinator; the letter would outline the training the apprentice received and would serve as a record of the apprentice's training.

Additionally, the individual conducting the installation must follow appropriate guidelines for the installation and use of artificial cavity inserts and drilled cavities, including: (1) Monitoring the cavity resource; (2) installing and maintaining the recommended number of suitable cavities in each cluster; (3) using the appropriate type of artificial cavity insert and method of artificial cavity installation; (4) installing artificial cavities as close to existing cavity trees as possible, preferably within 71 meters (200 feet); (5) selecting a tree that is of appropriate age or diameter when installing a cavity insert; (6) selecting the appropriate location for artificial cavity installation on the tree; and (7) protecting red-cockaded woodpeckers from sap leakage by ensuring that no artificial cavity has resin leaking into the chamber or entrance tunnel.

The 2003 red-cockaded woodpecker recovery plan can provide some additional detail on how an installer can ensure they successfully follow these guidelines (USFWS 2003, pp. 175–178). If an installer does not comply with the qualification requirements (*i.e.*, they have not held a valid Service permit or they have not completed the necessary training) or installation guidelines in the proposed 4(d) rule and incidental take occurs as a result of artificial cavity installation, the installer would still be liable for this take. However, if an installer is qualified and follows the installation guidelines, while incidental take is highly unlikely, if it were to occur, the installer would not be liable for such take under this proposed rule. We included this exception in our revised proposed 4(d) rule as a result of public comments on the October 8,

2020, proposal that supported its incorporation. The Service seeks comments on this exception (see Information Requested, above).

In addition to the exceptions we outline above, we may issue permits to carry out activities that could result in otherwise prohibited take of threatened wildlife under certain circumstances. Regulations governing permits are codified at 50 CFR 17.32. With regard to threatened wildlife, a permit may be issued for the following purposes: For scientific purposes, to enhance propagation or survival, for economic hardship, for zoological exhibition, for educational purposes, for incidental taking, or for special purposes consistent with the purposes of the Act. The statute also contains certain exemptions from the prohibitions, which are found in sections 9 and 10 of the Act.

#### Implications for Implementation

Nothing in this revised proposed section 4(d) rule would change in any way the recovery planning provisions of section 4(f) of the Act; the consultation requirements under section 7 of the Act, as noted above; or the ability of the Service to enter into partnerships for the management and protection of the red-cockaded woodpecker. However, interagency cooperation may be further streamlined through planned programmatic consultations for the species between Federal agencies and the Service, where appropriate.

Section 7(a)(2) of the Act requires Federal agencies, including the Service, to ensure that any action they fund, authorize, or carry out is not likely to jeopardize the continued existence of any endangered species or threatened species or result in the destruction or adverse modification of designated critical habitat of such species. In addition, section 7(a)(4) of the Act requires Federal agencies to confer with the Service on any agency action which is likely to jeopardize the continued existence of any species proposed to be listed under the Act or result in the destruction or adverse modification of proposed critical habitat.

As a result of these provisions in the Act, if a Federal action may affect a listed species or its critical habitat, the responsible Federal agency (action agency) must enter into consultation with us. Examples of actions that are subject to the section 7 consultation process are actions on State, Tribal, local, or private lands that require a Federal permit (such as a permit from the U.S. Army Corps of Engineers under section 404 of the Clean Water Act (33 U.S.C. 1251 *et seq.*) or a permit from the

Service under section 10 of the Act) or that involve some other Federal action (such as funding from the Federal Highway Administration, Federal Aviation Administration, Federal Emergency Management Agency, Natural Resources Conservation Service, or Partners for Fish and Wildlife Program). Federal actions that do not affect listed species or critical habitat—and actions on State, Tribal, local, or private lands that are not federally funded, authorized, or carried out by a Federal agency—do not require section 7 consultation.

The trigger for consultation is whether a Federal action may affect a listed species or its critical habitat, not whether the action would result in prohibited take; species-specific section 4(d) rules, regardless of the take they prohibit or allow, cannot change this requirement to consult. Consultation is still required to satisfy the requirements of section 7(a)(2) of the Act to ensure that the activity will not jeopardize the species or result in adverse modification of critical habitat. Thus, if a Federal agency determines that their action is not likely to adversely affect a listed species or its critical habitat, they must still receive the Service's written concurrence, even if this activity is excepted under a section 4(d) rule. If a Federal agency determines that their action is likely to adversely affect a listed species or its critical habitat, even if it only results in take that is excepted under a section 4(d) rule, they must still pursue formal consultation with the Service and the Service must formulate a biological opinion that includes an incidental take statement. Even if a section 4(d) rule includes specific exceptions to take prohibitions, the Service must still describe or enumerate the amount or extent of this incidental take that is reasonably certain to occur (*i.e.*, in an incidental take statement) and the Federal action agency must monitor and report any such take that occurs. If an action agency's activities exceed the amount of incidental take enumerated in the incidental take statement, it would trigger reinitiation of the consultation, even if this excessive take is still excepted under the section 4(d) rule (see *Center for Biological Diversity v. Salazar*, 695 F.3d 893 (2012)). This allows the agency to keep track of any take to stay abreast of the status of the species. The Federal action agency may also trigger reinitiation of consultation if they do not implement the proposed action as described in the biological opinion or as directed in the section 4(d) rule.

Even though section 4(d) rules do not remove or alter Federal agencies' section

7 consultation obligations, a section 4(d) rule can facilitate simplification of formal consultations. For example, as noted in our August 27, 2019, final rule regarding prohibitions for threatened species (84 FR 44753), in choosing to except take under certain circumstances in a section 4(d) rule, the Service has already determined that these forms of take are compatible with the species' conservation, which can streamline our analysis of whether an action would jeopardize the continued existence of the species, making consultation more straightforward and predictable. The Service plans to develop tools to streamline formal consultation for activities that do not result in prohibited take of red-cockaded woodpeckers. For example, given the nature of activities that would be consistent with this revised proposed section 4(d) rule, and as the revised proposed section 4(d) rule includes an explanation for why such activities provide for the conservation of the species, the Service could draft an analysis of the effects of these habitat management activities on the species for inclusion in all section 7 analyses that consider effects on the red-cockaded woodpecker. This analysis could be inserted verbatim into any Service biological opinion (or action agency biological assessment), thereby creating efficiencies in the development of these documents and providing consistency for consultation on activities that are covered by the section 4(d) rule.

Finally, if Federal agencies have already completed section 7 consultation on particular projects, activities, or management plans and the biological opinion remains valid, they do not need to reinitiate consultation if or when this 4(d) rule is finalized, if their Federal action (*e.g.*, management plan) has not changed. However, given the provisions in this revised proposed section 4(d) rule, Federal agencies may find that reinitiating consultation, although not required, could grant additional flexibilities for their management.

We will consider tools to streamline section 7 consultation on activities that may result in take that is excepted under this revised proposed 4(d) rule. We ask the public, particularly Federal and State agencies and other interested stakeholders that may be affected by the proposed section 4(d) rule, to provide comments and suggestions regarding additional guidance and methods that the Service could provide or use, respectively, to streamline the implementation of this proposed section 4(d) rule (see Information Requested, above).

## References Cited

A complete list of references cited in this document is available on the internet at <https://www.regulations.gov> and upon request from the person listed under **FOR FURTHER INFORMATION CONTACT**, above.

## Authors

The primary authors of this proposed rule are the staff members of the Fish and Wildlife Service's Species Assessment Team and the Louisiana, Georgia, and South Carolina Ecological Services Field Offices.

## List of Subjects in 50 CFR Part 17

Endangered and threatened species, Exports, Imports, Plants, Reporting and recordkeeping requirements, Transportation, Wildlife.

## Proposed Regulation Promulgation

Accordingly, we propose to further amend part 17, subchapter B of chapter I, title 50 of the Code of Federal Regulations, as proposed to be amended on October 9, 2018, at 83 FR 50560, and October 8, 2020, at 85 FR 63474, as set forth below:

## PART 17—ENDANGERED AND THREATENED WILDLIFE AND PLANTS

- 1. The authority citation for part 17 continues to read as follows:

**Authority:** 16 U.S.C. 1361–1407; 1531–1544; and 4201–4245, unless otherwise noted.

- 2. Amend § 17.41 by revising paragraph (h) to read as follows:

### § 17.41 Special rules—birds.

\* \* \* \* \*

(h) Red-cockaded woodpecker (*Dryobates borealis*). (1) *Definitions*. For the purposes of this paragraph (h), we define the following terms:

(i) *Habitat management activities* are activities intended to maintain or improve the quality and/or quantity of red-cockaded woodpecker habitat, including, but not limited to, prescribed burning; using herbicides and equipment to reduce midstory encroachment, thin overstocked pine stands, promote an open canopy pine system, and promote herbaceous groundcover; converting planted pines to more fire-tolerant, site-appropriate native pines found within the associated native pine, fire-dependent ecosystem; planting and seeding native, site-appropriate pines and groundcover species; and regenerating areas of older pine forest to increase and maintain sustainable current and future habitat for red-cockaded woodpeckers.

(ii) *Cavity tree* means any tree containing one or more active or inactive natural or artificial cavities.

(A) An *active cavity* is a completed natural or artificial cavity or cavity start exhibiting fresh pine resin associated with red-cockaded woodpeckers' cavity maintenance, cavity construction, or resin well excavation.

(B) An *inactive cavity* is a cavity that is not presently being used by red-cockaded woodpeckers.

(C) A *cavity start* is a void formed in the bole of the tree during the initial stages of cavity excavation and can be active or inactive.

(iii) *Cluster* means the aggregation of cavity trees within an area previously or currently used and defended by a single red-cockaded woodpecker group. A cluster may be active or inactive. A cluster encompasses the minimum convex polygon containing all of a group's cavity trees and the 61-meter (200-foot) buffer surrounding that polygon. The minimum cluster area size is 4.05 hectares (10 acres), as some clusters may contain only one cavity tree.

(A) An *active cluster* is defined as a cluster in which one or more of the cavity trees exhibit fresh resin as a result of red-cockaded woodpecker activity or in which one or more red-cockaded woodpeckers are observed.

(B) An *inactive cluster* is defined as a cluster that is not currently supporting any red-cockaded woodpeckers and shows no evidence of red-cockaded woodpecker activity.

(C) A *group* is a red-cockaded woodpecker social unit, consisting of a breeding pair with one or more helpers, a breeding pair without helpers, or a solitary male.

(iv) *Foraging habitat* is habitat that generally consists of mature pines with an open canopy, low densities of small pines, a sparse hardwood and/or pine midstory, few or no overstory hardwoods, and abundant native bunchgrass and forb groundcovers.

(2) *Prohibitions*. The following prohibitions in this paragraph (h)(2) that apply to endangered wildlife also apply to the red-cockaded woodpecker. Except as provided under paragraphs (h)(3) and (4) of this section and §§ 17.4 and 17.5, it is unlawful for any person subject to the jurisdiction of the United States to commit, to attempt to commit, to solicit another to commit, or cause to be committed, any of the following acts in regard to this species:

(i) Import or export, as set forth at § 17.21(b) for endangered wildlife.

(ii) Take, as set forth at § 17.21(c)(1) for endangered wildlife.



(iii) Possession and other acts with unlawfully taken specimens, as set forth at § 17.21(d)(1) for endangered wildlife.

(iv) Interstate or foreign commerce in the course of commercial activity, as set forth at § 17.21(e) for endangered wildlife.

(v) Sale or offer for sale, as set forth at § 17.21(f) for endangered wildlife.

(3) *General exceptions from prohibitions.* In regard to this species, you may:

(i) Conduct activities as authorized by a permit issued under § 17.32, such as permits associated with safe harbor agreements and habitat conservation plans.

(ii) Take, as set forth at § 17.21(c)(2) through (4) for endangered wildlife, and § 17.21(c)(6) and (7) for endangered migratory birds.

(iii) Take, as set forth at § 17.31(b).

(iv) Possess and engage in other acts with unlawfully taken red-cockaded woodpeckers, as set forth at § 17.21(d)(2) for endangered wildlife, and § 17.21(d)(3) and (4) for endangered migratory birds.

(4) *Exceptions from prohibitions for specific types of incidental take.* The following activities that cause take that is incidental to an otherwise lawful activity are not in violation of the prohibitions:

(i) *Department of Defense (DoD) installations.* Red-cockaded woodpecker habitat management and military training activities on DoD installations carried out in accordance with a U.S. Fish and Wildlife Service (Service)-approved integrated natural resources management plan, provided that the DoD installation reports annually to the Service regarding their red-cockaded woodpecker populations.

(ii) *Federal land management agency properties.* Habitat management activities intended to restore or maintain red-cockaded woodpecker habitat on Federal land management agency properties, provided that:

(A) The Federal land management agency details these habitat management activities in a Federal habitat management plan;

(B) The Federal habitat management activities incorporate appropriate

conservation measures to minimize or avoid adverse effects of these habitat management activities on red-cockaded woodpecker foraging habitat, on clusters, and on the species' roosting and nesting behavior to the maximum extent practicable; and

(C) The Federal land management agency reports annually to the Service regarding their red-cockaded woodpecker populations.

(iii) *Privately owned properties.*

Application of prescribed burns or herbicides on private lands when compatible with maintaining any known red-cockaded woodpecker populations, provided that the landowner or their representative:

(A) Follows applicable best management practices for prescribed burns and applicable Federal and State laws;

(B) Applies herbicides in a manner consistent with applicable best management practices and applicable Federal and State laws, including Environmental Protection Agency label restrictions and herbicide application guidelines as prescribed by manufacturers; and

(C) Applies prescribed burns and herbicides in a manner that minimizes or avoids adverse effects to known active clusters and red-cockaded woodpecker roosting and nesting behavior to the maximum extent practicable.

(iv) *Artificial cavities.* Installation, maintenance, and replacement of artificial cavity inserts and drilled cavities on public and private lands, provided that:

(A) The individual conducting the installation, maintenance, or replacement has either:

(1) Held a valid Service permit for that purpose in the past and has continued to install, maintain, and replace cavities since the expiration of their permit; or

(2) Completed the following training procedures for the type of artificial cavity they plan to install, maintain, or replace:

(i) The individual ("apprentice") has completed a period of apprenticeship to learn proper installation, maintenance,

and replacement procedures for artificial cavities under the direction of a person ("trainer") who has been actively installing, maintaining, and replacing cavities for at least the past 3 years;

(ii) The apprentice has installed at least 10 drilled cavities or 10 inserts under direct supervision of the trainer; and

(iii) The apprentice has learned the proper maintenance and inspection procedures for cavities and restrictor plates.

(B) If the individual conducting the installation is an apprentice, the apprentice's trainer provides a letter to the apprentice and to the Service red-cockaded woodpecker recovery coordinator that outlines the training the apprentice received, which will serve as a record of the apprentice's training.

(C) The individual conducting the installation follows appropriate guidelines for the installation and use of artificial cavity inserts and drilled cavities, including, but not limited to:

(1) Monitoring the cavity resource;

(2) Installing and maintaining the recommended number of suitable cavities in each cluster;

(3) Using the appropriate type of artificial cavity insert and method of artificial cavity installation;

(4) Installing artificial cavities as close to existing cavity trees as possible, preferably within 71 meters (200 feet);

(5) Selecting a tree that is of appropriate age or diameter, when installing a cavity insert;

(6) Selecting the appropriate location for artificial cavity installation on the tree; and

(7) Protecting red-cockaded woodpeckers from sap leakage by ensuring that no artificial cavity has resin leaking into the chamber or entrance tunnel.

**Martha Williams,**

*Principal Deputy Director, Exercising the Delegated Authority of the Director, U.S. Fish and Wildlife Service.*

[FR Doc. 2022-02006 Filed 2-2-22; 8:45 am]

**BILLING CODE 4333-15-P**

# Notices

Federal Register

Vol. 87, No. 23

Thursday, February 3, 2022

This section of the FEDERAL REGISTER contains documents other than rules or proposed rules that are applicable to the public. Notices of hearings and investigations, committee meetings, agency decisions and rulings, delegations of authority, filing of petitions and applications and agency statements of organization and functions are examples of documents appearing in this section.

## DEPARTMENT OF AGRICULTURE

### Office of the Secretary/Office of the Chief Scientist

#### Meeting Notice of the National Agricultural Research, Extension, Education, and Economics Advisory Board

**AGENCY:** Research, Education, and Economics, USDA.

**ACTION:** Notice of public meeting.

**SUMMARY:** In accordance with the Federal Advisory Committee Act, the National Agricultural Research, Extension, and Teaching Policy Act of 1977 and the Agriculture Improvement Act of 2018, the United States Department of Agriculture (USDA) announces a meeting of the National Agricultural Research, Extension, Education, and Economics Advisory Board.

**DATES:** The National Agricultural Research Extension, Education, and Economics Advisory Board will meet virtually by Zoom on February 9, 2022, from 11:00 a.m.–4:15 p.m. and February 10, 2022, from 11:00 a.m.–3:30 p.m. Eastern Time (ET). The public may file written comments before or up to February 24, 2022, with Shirley Morgan-Jordan, Program Support Coordinator by email at [nareee@usda.gov](mailto:nareee@usda.gov).

**ADDRESSES:** The meeting will take place virtually via Zoom.

**Web Preregistration:** Participants wishing to participate may preregister by emailing the NAREEE Advisory Board at [nareee@usda.gov](mailto:nareee@usda.gov). Upon registration you will receive an email link to participate by Zoom in the meeting.

Written comments may be sent to The National Agricultural Research, Extension, Education, and Economics Advisory Board Office, United States Department of Agriculture, 1400 Independence Avenue SW, Room 6019, The South Building, Washington, DC

20250–2255. We recommend you email all comments to [nareee@usda.gov](mailto:nareee@usda.gov) for receipt confirmation.

**FOR FURTHER INFORMATION CONTACT:** Kate Lewis, Executive Director/Designated Federal Official, or Shirley Morgan-Jordan, Program Support Coordinator, National Agricultural Research, Extension, Education, and Economics Advisory Board; telephone: (202) 631–1434 or (202) 380–5373 or email: [nareee@usda.gov](mailto:nareee@usda.gov).

#### SUPPLEMENTARY INFORMATION:

**Purpose of the meeting:** To provide advice and recommendations on the top priorities and policies for food and agricultural research, education, extension, and economics. The focus of this meeting will be on the deliberation of the report and recommendations of the relevance and adequacy review of the climate and energy needs programs of the USDA Research, Education, and Extension mission area and the Cooperative Extension activities of the land-grant university system. The Board will also hear from REE leadership and receive updates from the subcommittees of the Board. The latest agenda details will be available at <https://nareeeab.ree.usda.gov/meetings/general-meetings> or you may request a copy by email at [nareee@usda.gov](mailto:nareee@usda.gov).

On Wednesday, February 9, 2022 and February 10, 2022, the meeting will be held between 11:00 a.m. and 4:15 p.m. Eastern Time (ET) each day.

**Public Participation:** This meeting is open to the public. For any interested individuals, you may participate via internet and telephone. Opportunity for public comment will be offered. To attend the meeting via Zoom and/or make oral statements regarding any items on the agenda, you *must* contact Shirley Morgan-Jordan at email: [nareee@usda.gov](mailto:nareee@usda.gov) at least 5 business days prior to the meeting. Members of the public will be heard in the order in which they sign up at the beginning of the meeting. The Chair will conduct the meeting to facilitate the orderly conduct of business. Written comments by attendees or other interested stakeholders will be welcomed for the public record before and up to two weeks following the Board meeting (or by close of business February 24, 2022). All written statements must be sent to Shirley Morgan-Jordan, Program Support Coordinator, National Agricultural Research, Extension,

Education, and Economics Advisory Board, U.S. Department of Agriculture, Room 332A, Jamie L. Whitten Building, Mail Stop 0321, 1400 Independence Avenue SW, Washington, DC 20250–0321; or email: [nareee@usda.gov](mailto:nareee@usda.gov). All statements will become a part of the official record of the National Agricultural Research, Extension, Education, and Economics Advisory Board and will be kept on file for public review in the Research, Education, and Economics Advisory Board Office.

Dated: January 25, 2022.

**Cikena Reid,**

*USDA Committee Management Officer.*

[FR Doc. 2022–02019 Filed 2–2–22; 8:45 am]

**BILLING CODE 3410–03–P**

## DEPARTMENT OF AGRICULTURE

### Submission for OMB Review; Comment Request

The Department of Agriculture has submitted the following information collection requirement(s) to OMB for review and clearance under the Paperwork Reduction Act of 1995, Public Law 104–13. Comments are requested regarding; whether the collection of information is necessary for the proper performance of the functions of the agency, including whether the information will have practical utility; the accuracy of the agency's estimate of burden including the validity of the methodology and assumptions used; ways to enhance the quality, utility and clarity of the information to be collected; and ways to minimize the burden of the collection of information on those who are to respond, including through the use of appropriate automated, electronic, mechanical, or other technological collection techniques or other forms of information technology.

Comments regarding this information collection received by March 7, 2022 will be considered. Written comments and recommendations for the proposed information collection should be submitted within 30 days of the publication of this notice on the following website [www.reginfo.gov/public/do/PRAMain](http://www.reginfo.gov/public/do/PRAMain). Find this particular information collection by selecting “Currently under 30-day Review—Open for Public Comments” or by using the search function.

An agency may not conduct or sponsor a collection of information unless the collection of information displays a currently valid OMB control number and the agency informs potential persons who are to respond to the collection of information that such persons are not required to respond to the collection of information unless it displays a currently valid OMB control number.

#### Animal and Plant Health Inspection Service

*Title:* National Animal Health Monitoring System; Bison 2022 Study.

*OMB Control Number:* 0579-0420.

*Summary of Collection:* Collection and dissemination of animal health data and information is mandated by 7 U.S.C. 391, the Animal Industry Act of 1884, which established the precursor of the Animal and Plant Health Inspection Service (APHIS), Veterinary Services, the Bureau of Animal Industry. Legal requirements for examining and reporting on animal disease control methods were further mandated by 7 U.S.C. 8308 of the Animal Health Protection Act, "Detection, Control, and Eradication of Diseases and Pests," May 13, 2002. This collection of bison data is consistent with the APHIS mission of protecting and improving American agriculture's productivity and competitiveness.

In connection with this mission, the NAHMS program includes periodic national commodity studies to investigate current issues and examine general productivity, health, and management practices used on farms and their economic impact. These non-regulatory, voluntary studies are driven by industry and stakeholder interest.

*Need and Use of the Information:* APHIS will collect information using several forms. APHIS will use the data collected from the forms to address the following goals. (1) Update knowledge of national and regional health management and production practices and develop estimates for producer, veterinary, and industry reference; (2) Provide factual information on fencing and confinement, processing and marketing, and movement for U.S. bison operations; (3) Detect national and regional trends in disease emergence and movement such as the producer reporting of clinical signs of *Mycoplasma bovis*, malignant catarrhal fever, internal parasitism, and respiratory and enteric disease in bison; (4) Provide information useful to disease-spread models; and (5) Provide information on internal parasitism in bison, on antimicrobial resistance among isolates obtained from feces, and

on pasture forage nutritional quality. Without the information, the ability to respond to domestic and international trade issues involving the health status and production practices of the U.S. bison population would be severely reduced, potentially impacting the global marketability of animals, meat, and byproducts. Disease spread models would not have the necessary parameters to more accurately predict spread of an outbreak.

*Description of Respondents:* Business or other for-profit.

*Number of Respondents:* 2,000.

*Frequency of Responses:* Reporting: On occasion.

*Total Burden Hours:* 3,741.

Dated: January 6, 2022.

**Ruth Brown,**

*Departmental Information Collection Clearance Officer.*

[FR Doc. 2022-02210 Filed 2-2-22; 8:45 am]

**BILLING CODE 3410-34-P**

## DEPARTMENT OF AGRICULTURE

### Foreign Agricultural Service

#### Notice of Request for Extension of Currently Approved Information Collection.

**AGENCY:** Foreign Agricultural Service, USDA.

**ACTION:** Notice and request for comments.

**SUMMARY:** In accordance with the Paperwork Reduction Act (PRA) of 1995 this notice announces the intention of the Foreign Agricultural Service to request an extension of a currently approved information collection for the Agriculture Wool Apparel Manufacturers Trust Fund.

**DATES:** Comments on this notice must be received by April 4, 2022 to be assured of consideration.

**ADDRESSES:** You may send comments, identified by OMB Control Number 0551-0045, by any of the following methods:

- *Federal eRulemaking Portal:* <http://www.regulations.gov>. This portal enables respondents to enter short comments or attach a file containing lengthier comments.

- *Email:* [PODadmin@usda.gov](mailto:PODadmin@usda.gov). Include OMB Control Number 0551-0045 in the subject line of the message.

- *Mail, Courier, or Hand Delivery:* Curt Alt, U.S. Department of Agriculture, Foreign Agricultural Service, 1400 Independence Avenue SW, Room 6512, Washington, DC 20250.

*Instructions:* All submissions received must include the agency names and

OMB Control Number for this notice. All comments received will be posted without change, including any personal information provided.

**FOR FURTHER INFORMATION CONTACT:** Curt Alt, 202 690-4784, [Podadmin@usda.gov](mailto:PODadmin@usda.gov).

#### SUPPLEMENTARY INFORMATION:

*Title:* Agriculture Wool Apparel Manufacturers Trust Fund.

*OMB Control Number:* 0551-0045.

*Expiration Date of Approval:* January 31, 2022.

*Type of Request:* Extension of a currently approved information collection.

*Abstract:* This information collection is required for affidavits submitted to FAS for claims against the Agriculture Wool Apparel Manufacturers Trust Fund. Claimants of the Agriculture Wool Apparel Manufacturers Trust Fund will be required to submit electronically a notarized affidavit and information pertaining to the production of worsted wool suits, suit-type jackets, or trousers for boys and men; or the weaving of wool yarn, wool fiber, or wool top.

*Estimate of Burden:* Public reporting burden for this collection of information is estimated to average approximately 2 hours per response for affidavits related to the Agriculture Wool Apparel Manufacturers Trust Fund.

*Type of Respondents:* Under the Agriculture Wool Apparel Manufacturers Trust Fund there are four groups of potential respondents, as authorized by Section 12315 of the Agriculture Act of 2014 (Pub. L. 113-79), and reauthorized under Section 12603 of the Agriculture Improvement Act of 2018 (Pub. L. 115-334): (1) Persons in the United States who produced worsted wool suits, suit-type jackets, or trousers for men and boys in the year prior to the application using worsted wool fabric of the kind described in headings 9902.51.11, 9902.51.15, or who wove worsted wool fabrics suitable for use in making men and boys suits under heading 9902.51.16 of the Harmonized Tariff Schedule of the United States; (2) Persons in the United States who processed wool yarn, wool fiber, or wool top of the kind described in headings 9902.51.13 or 9902.51.14 of the Harmonized Tariff Schedule of the United States in the year prior to the application; (3) Persons in the United States who wove worsted wool fabrics of the kind described in headings 9902.51.11 and or 9902.51.15 of the Harmonized Tariff Schedule of the United States in the year prior to the application and in the years 1999, 2000,

and 2001; (4) Persons in the United States who manufactured certain wool articles made with certain imported wool products during calendar years 2000, 2001, and 2002; received a 2005 payment under section 505 of the Trade and Development Act of 2000; and who continue to be a manufacturer in the United States as provided for in Section 505(a) of the Trade and Development Act of 2000.

*Estimated Number of Respondents:* 95.

*Estimated Number of Responses:* 95.

*Estimated Number of Responses per Respondent:* 1.

*Estimated Total Annual Burden on Respondents:* 190 hours.

Copies of this information collection can be obtained from Dacia Rogers, the Agency Information Collection Coordinator, at [Dacia.Rogers@usda.gov](mailto:Dacia.Rogers@usda.gov).

*Request for Comments:* Send comments regarding (a) whether the proposed collection of information is necessary for the proper performance of the functions of the agency, including whether the information will have practical utility; (b) the accuracy of the agency's estimate of the burden of the collection of information including validity of the methodology and assumption used; (c) ways to enhance the quality, utility, and clarity of the information to be collected; and (d) ways to minimize the burden of the collection of information on those who are to respond, including through the use of automated, electronic, mechanical, or other technological collection techniques or other forms of information technology.

All comments received in response to this notice, including names and addresses when provided, will be a matter of public record. Comments will be available without change, including any personal information provided, for inspection online at <http://www.regulations.gov> and at the mail address listed above between 8:00 a.m. and 4:30 p.m., Monday through Friday, except holidays.

Comments will be summarized and included in the submission for Office of Management and Budget approval.

Persons with disabilities who require an alternative means for communication of information (Braille, large print, audiotape, etc.) should contact [FAS-ReasonableAccommodation@usda.gov](mailto:FAS-ReasonableAccommodation@usda.gov) or Jeffrey Galloway (Office of Civil Rights, 202-690-1399).

**Daniel Whitley,**

*Administrator, Foreign Agricultural Service.*

[FR Doc. 2022-02129 Filed 2-2-22; 8:45 am]

**BILLING CODE 3410-10-P**

## DEPARTMENT OF AGRICULTURE

### Forest Service

#### El Dorado County Resource Advisory Committee

**AGENCY:** Forest Service, Agriculture (USDA).

**ACTION:** Notice of virtual meeting.

**SUMMARY:** The El Dorado County Resource Advisory Committee (RAC) will hold a virtual meeting. The committee is authorized under the Secure Rural Schools and Community Self-Determination Act (the Act) and operates in compliance with the Federal Advisory Committee Act. The purpose of the committee is to improve collaborative relationships and to provide advice and recommendations to the Forest Service concerning projects and funding consistent with the Act. RAC information can be found at the following website: <https://www.fs.usda.gov/main/eldorado/workingtogether/advisorycommittees>.

**DATES:** The meeting will be held on Thursday, March 3, 2022, 3:30 p.m.–5:30 p.m., Pacific Standard Time.

All RAC meetings are subject to cancellation. For status of the meeting prior to attendance, please contact the person listed under **FOR FURTHER INFORMATION CONTACT**.

**ADDRESSES:** The meeting is open to the public and will be held with virtual attendance only. For virtual meeting information, please contact the person listed under **FOR FURTHER INFORMATION CONTACT**.

Written comments may be submitted as described under **SUPPLEMENTARY INFORMATION**. All comments, including names and addresses when provided, are placed in the record and are available for public inspection and copying. The public may inspect comments received at: Eldorado National Forest Supervisor's Office, 100 Forni Road, Placerville, CA. Please call ahead to facilitate entry into the building.

**FOR FURTHER INFORMATION CONTACT:** Jennifer Chapman, Public Affairs Officer by phone at 530-957-9660 or via email at [jennifer.chapman@usda.gov](mailto:jennifer.chapman@usda.gov).

Individuals who use telecommunication devices for the deaf/hard-of-hearing (TDD) may call the Federal Relay Service (FRS) at 1-800-877-8339, 24 hours a day, every day of the year, including holidays.

**SUPPLEMENTARY INFORMATION:** The purpose of the meeting is to discuss the upcoming call for proposals and other RAC updates.

The meeting is open to the public. The agenda will include time for people to make oral statements of three minutes or less. Individuals wishing to make an oral statement should request in writing 7 days before the meeting to be scheduled on the agenda. Anyone who would like to bring related matters to the attention of the committee may file written statements with the committee staff before or after the meeting. Written comments and requests for time to make oral comments must be sent to Jennifer Chapman, Eldorado National Forest, 100 Forni Road, Placerville, CA 95667; by email to [jennifer.chapman@usda.gov](mailto:jennifer.chapman@usda.gov); or via facsimile to 530-621-5297.

*Meeting Accommodations:* Please make requests in advance for sign language interpreter services, assistive listening devices, or other reasonable accommodation. For access to proceedings, please contact the person listed in the section titled **FOR FURTHER INFORMATION CONTACT**. All reasonable accommodation requests are managed on a case-by-case basis.

Equal opportunity practices, in line with USDA policies, will be followed in all membership appointments to the RAC. To help ensure that recommendations of the RAC have taken into account the needs of the diverse groups served by the Department, membership shall include, to the extent practicable, individuals with demonstrated ability to represent minorities, women, and persons with disabilities.

The USDA prohibits discrimination in all of its programs and activities on the basis of race, color, national origin, religion, sex, gender identity (including gender expression), sexual orientation, disability, age, marital status, family/parental status, political beliefs, income derived from a public assistance program, or reprisal or retaliation for prior civil rights activity in any program or activity conducted or funded by USDA (not all bases apply to all programs).

Dated: January 28, 2022.

**Cikena Reid,**

*USDA Committee Management Officer.*

[FR Doc. 2022-02174 Filed 2-2-22; 8:45 am]

**BILLING CODE 3411-15-P**

## DEPARTMENT OF AGRICULTURE

### Forest Service

#### El Dorado County Resource Advisory Committee; Meeting

**AGENCY:** Forest Service, Agriculture (USDA).

**ACTION:** Notice of virtual meeting.

**SUMMARY:** The El Dorado County Resource Advisory Committee (RAC) will hold a virtual meeting. The committee is authorized under the Secure Rural Schools and Community Self-Determination Act (the Act) and operates in compliance with the Federal Advisory Committee Act. The purpose of the committee is to improve collaborative relationships and to provide advice and recommendations to the Forest Service concerning projects and funding consistent with the Act. RAC information can be found at the following website: <https://www.fs.usda.gov/main/eldorado/workingtogether/advisorycommittees>.

**DATES:** The meeting will be held on Wednesday, February 16, 2022, 3:30 p.m.–5:30 p.m., Pacific Standard Time.

All RAC meetings are subject to cancellation. For status of the meeting prior to attendance, please contact the person listed under **FOR FURTHER INFORMATION CONTACT**.

**ADDRESSES:** The meeting is open to the public and will be held with virtual attendance only. For virtual meeting information, please contact the person listed under **FOR FURTHER INFORMATION CONTACT**.

Written comments may be submitted as described under **SUPPLEMENTARY INFORMATION**. All comments, including names and addresses when provided, are placed in the record and are available for public inspection and copying. The public may inspect comments received at: El Dorado National Forest Supervisor's Office, 100 Forni Road, Placerville, CA. Please call ahead to facilitate entry into the building.

**FOR FURTHER INFORMATION CONTACT:** Jennifer Chapman, Public Affairs Officer by phone at (530) 957-9660 or via email at [jennifer.chapman@usda.gov](mailto:jennifer.chapman@usda.gov).

Individuals who use telecommunication devices for the deaf/hard-of-hearing (TDD) may call the Federal Relay Service (FRS) at 1-800-877-8339, 24 hours a day, every day of the year, including holidays.

**SUPPLEMENTARY INFORMATION:** The purpose of the meeting is to discuss the upcoming call for proposals and other RAC updates.

The meeting is open to the public. The agenda will include time for people to make oral statements of three minutes or less. Individuals wishing to make an oral statement should request in writing 7 days before the meeting to be scheduled on the agenda. Anyone who would like to bring related matters to the attention of the committee may file

written statements with the committee staff before or after the meeting. Written comments and requests for time to make oral comments must be sent to Jennifer Chapman, El Dorado National Forest, 100 Forni Road, Placerville, CA 95667; by email to [jennifer.chapman@usda.gov](mailto:jennifer.chapman@usda.gov); or via facsimile to (530) 621-5297.

**Meeting Accommodations:** Please make requests in advance for sign language interpreter services, assistive listening devices, or other reasonable accommodation. For access to proceedings, please contact the person listed in the section titled **FOR FURTHER INFORMATION CONTACT**. All reasonable accommodation requests are managed on a case-by-case basis.

Equal opportunity practices, in line with USDA policies, will be followed in all membership appointments to the RAC. To help ensure that recommendations of the RAC have taken into account the needs of the diverse groups served by the Department, membership shall include, to the extent practicable, individuals with demonstrated ability to represent minorities, women, and persons with disabilities.

The USDA prohibits discrimination in all of its programs and activities on the basis of race, color, national origin, religion, sex, gender identity (including gender expression), sexual orientation, disability, age, marital status, family/parental status, political beliefs, income derived from a public assistance program, or reprisal or retaliation for prior civil rights activity in any program or activity conducted or funded by USDA (not all bases apply to all programs).

Dated: January 28, 2022.

**Cikena Reid,**

*USDA Committee Management Officer.*

[FR Doc. 2022-02170 Filed 2-2-22; 8:45 am]

**BILLING CODE 3411-15-P**

## DEPARTMENT OF AGRICULTURE

### Forest Service

#### Dixie Resource Advisory Committee

**AGENCY:** Forest Service, Agriculture (USDA).

**ACTION:** Notice of meeting.

**SUMMARY:** The Dixie Resource Advisory Committee (RAC) will hold a virtual meeting by phone and/or video conference. The committee is authorized under the Secure Rural Schools and Community Self-Determination Act (the Act) and operates in compliance with the Federal Advisory Committee Act. The purpose

of the committee is to improve collaborative relationships and to provide advice and recommendations to the Forest Service concerning projects and funding consistent with Title II of the Act, as well as make recommendations on recreation fee proposals for sites on the Dixie National Forest within Garfield, Iron, Kane, and Washington Counties, consistent with the Federal Lands Recreation Enhancement Act. RAC information and virtual meeting information can be found at the following website: <https://www.fs.usda.gov/main/dixie/workingtogether/advisorycommittees>.

**DATES:** The meeting will be held on March 10, 2022, 9:00 a.m.–12:00 p.m., Mountain Standard Time.

All RAC meetings are subject to cancellation. For status of the meeting prior to attendance, please contact the person listed under **FOR FURTHER INFORMATION CONTACT**.

**ADDRESSES:** The meeting will be held virtually via telephone and/or video conference. Details on how members of the public can join the meeting can be found at the website link in the above **SUMMARY**.

Written comments may be submitted as described under **SUPPLEMENTARY INFORMATION**. All comments, including names and addresses when provided, are placed in the record and are available for public inspection and copying. The public may inspect comments received upon request.

**FOR FURTHER INFORMATION CONTACT:** Steven O'Neil, Designated Federal Officer (DFO), by phone at 435-865-3753 or email at [steven.oneil1@usda.gov](mailto:steven.oneil1@usda.gov) or Wendy Soper, RAC Coordinator, at 435-865-3794 or email at [wendy.soper@usda.gov](mailto:wendy.soper@usda.gov).

Individuals who use telecommunication devices for the deaf/hard-of-hearing (TDD) may call the Federal Relay Service (FRS) at 1-800-877-8339, 24 hours a day, every day of the year, including holidays.

**SUPPLEMENTARY INFORMATION:** The purpose of the meeting is to:

1. Review RAC roles and responsibilities;
2. Hear from Title II project proponents and discuss Title II project proposals; and
3. Schedule the next meeting.

The meeting is open to the public. The agenda will include time for people to make oral statements of three minutes or less. Individuals wishing to make an oral statement should make a request in writing by March 1, 2022, to be scheduled on the agenda. Anyone who would like to bring related matters to the attention of the committee may file

written statements with the committee staff before or after the meeting. Written comments and requests for time for oral comments must be sent to Steven O'Neil, Dixie National Forest, 820 N Main, Cedar City, UT 84721; or by email to [steven.oneil@usda.gov](mailto:steven.oneil@usda.gov).

**Meeting Accommodations:** Please make requests in advance for sign language interpreter services, assistive listening devices, or other reasonable accommodation. For access to proceedings, please contact the person listed in the section titled **FOR FURTHER INFORMATION CONTACT**. All reasonable accommodation requests are managed on a case-by-case basis.

Equal opportunity practices, in line with USDA policies, will be followed in all membership appointments to the RAC. To help ensure that recommendations of the RAC have taken into account the needs of the diverse groups served by the Department, membership shall include, to the extent practicable, individuals with demonstrated ability to represent minorities, women, and persons with disabilities.

The USDA prohibits discrimination in all of its programs and activities on the basis of race, color, national origin, religion, sex, gender identity (including gender expression), sexual orientation, disability, age, marital status, family/parental status, political beliefs, income derived from a public assistance program, or reprisal or retaliation for prior civil rights activity in any program or activity conducted or funded by USDA (not all bases apply to all programs).

Dated: January 28, 2022.

**Cikena Reid,**

*USDA Committee Management Officer.*

[FR Doc. 2022-02172 Filed 2-2-22; 8:45 am]

**BILLING CODE 3411-15-P**

## DEPARTMENT OF AGRICULTURE

### Forest Service

#### Yavapai Resource Advisory Committee Meeting

**AGENCY:** Forest Service, Agriculture (USDA).

**ACTION:** Notice of virtual meeting.

**SUMMARY:** The Yavapai Resource Advisory Committee (RAC) will hold a virtual meeting by phone and/or video conference. The committee is authorized under the Secure Rural Schools and Community Self-Determination Act (the Act) and operates in compliance with the Federal Advisory Committee Act. The purpose

of the committee is to improve collaborative relationships and to provide advice and recommendations to the Forest Service concerning projects and funding consistent with Title II of the Act. RAC information and virtual meeting information can be found at the following website: <https://www.fs.usda.gov/main/prescott/working-together/advisorycommittees>.

**DATES:** The meeting will be held on March, 1, 2022, 12:00 p.m.–4:00 p.m., Mountain Standard Time.

All RAC meetings are subject to cancellation. For status of the meeting prior to attendance, please contact the person listed under **FOR FURTHER INFORMATION CONTACT**.

**ADDRESSES:** The meeting is open to the public and will be held virtually via telephone and/or video conference. Virtual meeting participation details can be found on the website listed under *Summary* or can be obtained by contacting the person listed under **FOR FURTHER INFORMATION CONTACT**.

Written comments may be submitted as described under **SUPPLEMENTARY INFORMATION**. All comments, including names and addresses when provided, are placed in the record and are available for public inspection and copying. The public may inspect comments received upon request.

**FOR FURTHER INFORMATION CONTACT:** Debbie Maneely, RAC Coordinator at 928-499-4736 or email at [debbie.maneely@usda.gov](mailto:debbie.maneely@usda.gov).

Individuals who use telecommunication devices for the deaf/hard-of-hearing (TDD) may call the Federal Relay Service (FRS) at 1-800-877-8339, 24 hours a day, every day of the year, including holidays.

**SUPPLEMENTARY INFORMATION:** The purpose of the meeting is to:

1. Make funding recommendations on Title II projects;
2. Schedule the next meeting; and
3. Discuss reauthorization for FY2021–FY2023.

The meeting is open to the public. Anyone who would like to bring related matters to the attention of the committee may file written statements with the committee staff before or after the meeting. Written comments and requests for time for oral comments must be sent to Debbie Maneely, RAC Coordinator, 735 N Highway 89, Chino Valley, Arizona 86323; or by email to [debbie.maneely@usda.gov](mailto:debbie.maneely@usda.gov).

**Meeting Accommodations:** Please make requests in advance for sign language interpreter services, assistive listening devices, or other reasonable accommodation. For access to proceedings, please contact the person

listed in the section titled **FOR FURTHER INFORMATION CONTACT**. All reasonable accommodation requests are managed on a case-by-case basis.

Equal opportunity practices, in line with USDA policies, will be followed in all membership appointments to the RAC. To help ensure that recommendations of the RAC have taken into account the needs of the diverse groups served by the Department, membership shall include, to the extent practicable, individuals with demonstrated ability to represent minorities, women, and persons with disabilities.

The USDA prohibits discrimination in all of its programs and activities on the basis of race, color, national origin, religion, sex, gender identity (including gender expression), sexual orientation, disability, age, marital status, family/parental status, political beliefs, income derived from a public assistance program, or reprisal or retaliation for prior civil rights activity in any program or activity conducted or funded by USDA (not all bases apply to all programs).

Dated: January 28, 2022.

**Cikena Reid,**

*USDA Committee Management Officer.*

[FR Doc. 2022-02173 Filed 2-2-22; 8:45 am]

**BILLING CODE 3411-15-P**

## DEPARTMENT OF AGRICULTURE

### Forest Service

#### Collaborative Forest Landscape Restoration Advisory Panel

**AGENCY:** Forest Service, Agriculture (USDA).

**ACTION:** Call for nominations.

**SUMMARY:** The Collaborative Forest Landscape Restoration Advisory Panel (Panel) was renewed on January 11, 2022, to evaluate and provide recommendations on the selection of collaborative forest landscape restoration proposals to the Secretary of Agriculture (Secretary) for approval as provided in Section 8629 of the Agriculture Improvement Act of 2018. The Secretary has determined that the work of the Panel is in the public's interest and relevant to the duties of the Department of Agriculture. Therefore, the Secretary is seeking nominations to fill vacancies on the Panel. The Panel is a statutory committee. Additional information concerning the Panel can be found by visiting the Panel's website at: <https://www.fs.fed.us/restoration/CFLRP/advisory-panel.shtml>.

**DATES:** Nominations must be received by March 7, 2022. Nominations must contain a completed application packet that includes the nominee's name, resume, references, and completed Form AD-755 (Advisory Committee or Research and Promotion Background Information). The package must be sent to the address below.

**ADDRESSES:** Send nominations and applications to Lindsay Buchanan, [lindsay.buchanan@usda.gov](mailto:lindsay.buchanan@usda.gov), USDA Forest Service, Forest Management, Range Management and Vegetation Ecology, 201 14th Street SW, Room 3SW, Washington, DC 20024 by express mail or overnight courier service. If sent via the U.S. Postal Service, please send to the following address: USDA, Forest Service, Forest Management, National Forest System, Mail Stop 1103, 1400 Independence Avenue SW, Washington, DC 20250-1123.

**FOR FURTHER INFORMATION CONTACT:** Lindsay Buchanan, USDA, National Forest System, Forest Management, Range Management, and Vegetation Ecology, by phone at 202-365-2600 or by email at [lindsay.buchanan@usda.gov](mailto:lindsay.buchanan@usda.gov). Individuals who use telecommunication devices for the deaf and hard of hearing (TDD) may call the Federal Relay Service (FRS) at 1-800-877-8339, 24 hours a day, every day of the year, including holidays.

**SUPPLEMENTARY INFORMATION:**

**Background**

The purpose of the Collaborative Forest Landscape Restoration Program is to increase active management to improve forest health, reduce the risk of catastrophic wildfires, and promote jobs in rural economies through a process that:

- (1) Encourages ecological, economic, and social sustainability;
- (2) Leverages local resources with national and private resources;
- (3) Facilitates the reduction of wildfire management costs, including through reestablishing natural fire regimes and reducing the risk of uncharacteristic wildfire; and
- (4) Demonstrates the degree to which:
  - (a) Various ecological restoration techniques
    - (i) achieve ecological and watershed health objectives;
    - (ii) affect wildfire activity and management costs; and
    - (b) The use of forest restoration byproducts can offset treatment costs while benefiting local rural economies and improving forest health.

The duties of the Committee include:

1. Evaluating Collaborative Forest Landscape Restoration project proposals with special consideration given to:

- a. The strength of the proposal and strategy;
- b. the strength of the ecological case of the proposal and the proposed ecological restoration strategies;
- c. the strength of the collaborative process and the likelihood of successful collaboration throughout implementation;
- d. whether the proposal is likely to reduce the risk of uncharacteristic wildfire and reestablish natural fire regimes;
- e. whether the proposal would use restoration byproducts to reduce the relative costs of carrying out ecological restoration treatments and benefit local economies; and
- f. whether the proposal is in alignment with a shared stewardship approach, including leveraging an appropriate level of non-Federal investments.

2. Provide recommendations on each proposal to the Secretary of Agriculture through the Chief of the Forest Service.

**Advisory Committee Organization**

The Committee shall be comprised of no more than 15 members approved by the Secretary of Agriculture where each will serve a 2-year term, although appointments shall have staggered terms. The Committee membership will be fairly balanced in terms of the points of view represented and functions to be performed. Non-Federal members of the Committee shall serve without pay but will be reimbursed for reasonable costs incurred while performing duties on behalf of the Committee, subject to approval by the Designated Federal Officer (DFO). The Committee shall include representation from experts in the following interest areas:

1. Ecological Restoration,
2. Fire Ecology,
3. Fire Management,
4. Rural Economic Development,
5. Strategies for Ecological Adaptation to Climate Change,
6. Fish and Wildlife Ecology, and
7. Woody Biomass and Small-Diameter Tree Utilization.

Of these members, one will become the Chairperson who is recognized for his/her ability to lead a group in a fair and focused manner and who has been briefed on the mission of this Committee. The Committee will meet on an annual basis or as needed. This will be determined by the Committee. Vacancies will be filled in the manner in which the original appointment was made.

**Nomination and Application Information**

The appointment of members to the Committee will be made by the

Secretary of Agriculture. The public is invited to submit nominations for membership on the Committee, either self-nomination or nomination of any qualified and interested person. Any individual or organization may nominate one or more qualified persons to represent the interest areas listed above. To be considered for membership, nominees must:

1. Identify what interest area group listed above they would represent and how they are qualified to represent that interest group;
2. State why they want to serve on the Committee and what they can contribute;
3. Provide 2-3 references that may be contacts about the nominee's application;

4. Provide a resume showing their past experience in working successfully as part of a coordinating group; and

5. Complete Form AD-755, Advisory Committee or Research and Promotion Background Information. Form AD-755 may be obtained from the listed Forest Service contact persons or from the following website: <https://www.usda.gov/sites/default/files/documents/ad-755.pdf>.

Letters of recommendation are welcome. All nominations will be vetted by the Agency.

Equal opportunity practices, in line with USDA policies, will be followed in all membership appointments to the RAC. To help ensure that recommendations of the RAC have taken into account the needs of the diverse groups served by the Department, membership shall include, to the extent practicable, individuals with demonstrated ability to represent minorities, women, and persons with disabilities.

The USDA prohibits discrimination in all of its programs and activities on the basis of race, color, national origin, religion, sex, gender identity (including gender expression), sexual orientation, disability, age, marital status, family/parental status, political beliefs, income derived from a public assistance program, or reprisal or retaliation for prior civil rights activity in any program or activity conducted or funded by USDA (not all bases apply to all programs).

Dated: January 28, 2022.

**Cikena Reid,**

*USDA Committee Management Officer.*

[FR Doc. 2022-02192 Filed 2-2-22; 8:45 am]

**BILLING CODE 3411-15-P**

## DEPARTMENT OF COMMERCE

## Foreign-Trade Zones Board

[S-179-2021]

**Approval of Subzone Status; Valbruna Stainless, Inc.; Pompton Lakes, New Jersey**

On November 19, 2021, the Acting Executive Secretary of the Foreign-Trade Zones (FTZ) Board docketed an application submitted by the Port Authority of New York and New Jersey, grantee of FTZ 49, requesting subzone status subject to the existing activation limit of FTZ 49, on behalf of Valbruna Stainless, Inc., in Pompton Lakes, New Jersey.

The application was processed in accordance with the FTZ Act and Regulations, including notice in the **Federal Register** inviting public comment (86 FR 67435, November 26, 2021). The FTZ staff examiner reviewed the application and determined that it meets the criteria for approval. Pursuant to the authority delegated to the FTZ Board Executive Secretary (15 CFR Sec. 400.36(f)), the application to establish Subzone 49X was approved on January 31, 2022, subject to the FTZ Act and the Board's regulations, including Section 400.13, and further subject to FTZ 49's 2,000-acre activation limit.

Dated: January 31, 2022.

**Andrew McGilvray,**

*Executive Secretary.*

[FR Doc. 2022-02261 Filed 2-2-22; 8:45 am]

BILLING CODE 3510-DS-P

## DEPARTMENT OF COMMERCE

## International Trade Administration

[A-570-051]

**Certain Hardwood Plywood Products From the People's Republic of China: Preliminary Results of Antidumping Duty Administrative Review and Preliminary Determination of No Shipments; 2020**

**AGENCY:** Enforcement and Compliance, International Trade Administration, Department of Commerce.

**SUMMARY:** The Department of Commerce (Commerce) preliminarily determines that 17 exporters of certain hardwood plywood products (hardwood plywood) from the People's Republic of China (China) under review had no shipments of subject merchandise during the period of review (POR) January 1, 2020, through December 31, 2020. Commerce also preliminarily determines that the remaining 39 remaining companies

subject to this review are part of the China-wide entity because they did not demonstrate eligibility for separate rates.

**DATES:** Applicable February 3, 2022.

**FOR FURTHER INFORMATION CONTACT:** Kabir Archuletta, AD/CVD Operations, Office V, Enforcement and Compliance, International Trade Administration, U.S. Department of Commerce, 1401 Constitution Avenue NW, Washington, DC 20230; telephone: (202) 482-2593.

**SUPPLEMENTARY INFORMATION:****Background**

On March 4, 2021, Commerce published in the **Federal Register** a notice of initiation of an administrative review of the antidumping duty (AD) order<sup>1</sup> on hardwood plywood from China with respect to 56 exporters.<sup>2</sup> Subsequently, we released U.S. Customs and Border Protection (CBP) data to interested parties for comment.<sup>3</sup> We received comments from the petitioner.<sup>4</sup> No other interested party commented on the CBP data.

From March 30 to April 5, 2021, we received timely no-shipment certifications from 17 companies.<sup>5</sup> We did not receive a no-shipment statement, separate rate application (SRA), or separate rate certification (SRC) from any other company subject to this review. On June 14, 2021, we received a request from the petitioner that we conduct verification of the information submitted in this review.<sup>6</sup> On October 1, 2021, Commerce

<sup>1</sup> See *Certain Hardwood Plywood Products from the People's Republic of China: Amended Final Determination of Sales at Less Than Fair Value, and Antidumping Duty Order*, 83 FR 504 (January 4, 2018) (*Order*).

<sup>2</sup> See *Initiation of Antidumping and Countervailing Duty Administrative Reviews*, 86 FR 12599 (March 4, 2021) (*Initiation Notice*).

<sup>3</sup> See Memorandum, "Release of U.S. Customs and Border Protection Data," dated March 10, 2021.

<sup>4</sup> The petitioner is the Coalition for Fair Trade in Hardwood Plywood. See Petitioner's Letter, "Hardwood Plywood Products from the People's Republic of China: Comments on CBP Data," dated March 17, 2021.

<sup>5</sup> We received timely no-shipment certifications from the following companies: (1) Celtic Co., Ltd.; (2) Cosco Star International Co., Ltd.; (3) Happy Wood Industrial Group Co., Ltd.; (4) Jiaying Hengtong Wood Co., Ltd.; (5) Linyi Evergreen Wood Co., Ltd.; (6) Linyi Glary Plywood Co., Ltd.; (7) Linyi Huasheng Yongbin Wood Co., Ltd.; (8) Linyi Jiahe Wood Industry Co., Ltd.; (9) Linyi Sanfortune Wood Co., Ltd.; (10) Qingdao Top P&Q International Corp.; (11) Shandong Qishan International Trading Co., Ltd.; (12) Shanghai Brightwood Trading Co., Ltd.; (13) Shanghai Futuwood Trading Co., Ltd.; (14) Shanghai Luli Trading Co., Ltd.; (15) Suqian Hopeway International Trade Co., Ltd.; (16) Xuzhou Jiangyang Wood Industries Co., Ltd.; and (17) Zhejiang Dehua TB Import & Export Co., Ltd.

<sup>6</sup> See Petitioner's Letter, "Request for Verification," dated June 14, 2021.

extended the time limit for completing the preliminary results of this review to January 28, 2022.<sup>7</sup>

For a complete description of the events that followed the initiation of this administrative review, see the Preliminary Decision Memorandum.<sup>8</sup> A list of topics included in the Preliminary Decision Memorandum is provided in Appendix III to this notice. The Preliminary Decision Memorandum is a public document and is on file electronically *via* Enforcement and Compliance's Antidumping and Countervailing Duty Centralized Electronic Service System (ACCESS). ACCESS is available to registered users at <http://access.trade.gov>. In addition, a complete version of the Preliminary Decision Memorandum can be found at <http://enforcement.trade.gov/frn/>. The signed and the electronic versions of the Preliminary Decision Memorandum are identical in content.

**Scope of the Order**

The product covered by the order is hardwood plywood from China. A full description of the scope of the order is contained in the Preliminary Decision Memorandum.<sup>9</sup>

**Methodology**

Commerce is conducting this review in accordance with section 751(a)(1)(B) of the Tariff Act of 1930, as amended (the Act) and 19 CFR 351.213.

**Preliminary Determination of No Shipments**

Based upon the no shipment certifications received by Commerce, and our review of the CBP data, we preliminarily find that 17 companies had no shipments during the POR. Commerce requested that CBP confirm whether any shipments of subject merchandise entered the United States during the POR with respect to the 17 companies that submitted no shipment claims, and CBP responded that it has no record of any subject entries for these 17 inquiries.<sup>10</sup> Because we have

<sup>7</sup> See Memorandum, "Extension of Deadline for Preliminary Results of Antidumping Duty Administrative Review, 2020," dated October 1, 2021. See also Memorandum, "Clarification of Extension of Deadline for Preliminary Results of Antidumping Duty Administrative Review, 2020," dated October 13, 2021.

<sup>8</sup> See Memorandum, "Decision Memorandum for the Preliminary Results for the 2020 Antidumping Duty Administrative Review: Certain Hardwood Plywood from the People's Republic of China," dated concurrently with, and hereby adopted by, this notice (Preliminary Decision Memorandum).

<sup>9</sup> *Id.*

<sup>10</sup> See Memorandum "No Shipment Inquiries for Multiple Companies during the period 01/01/2020 through 12/31/2020," dated April 16, 2021.



corroborated the 17 no-shipment claims with CBP, we have verified these claims for purposes of these preliminary results, in accordance with section 782(i) of the Act. For additional information regarding this determination, see the Preliminary Decision Memorandum. Consistent with our assessment in non-market economy administrative reviews,<sup>11</sup> Commerce is not rescinding this review for these 17 companies.<sup>12</sup> Commerce intends to complete this review and issue appropriate instructions to CBP based on the final results of this review.

### Separate Rates

Because the other 39 companies under review did not submit a no-shipment certification, SRA, or SRC, Commerce preliminarily determines that these companies have not demonstrated their eligibility for separate rates.<sup>13</sup> For additional information, see the Preliminary Decision Memorandum.

### China-Wide Entity

Commerce's policy regarding conditional review of the China-wide entity applies to this administrative review.<sup>14</sup> Under this policy, the China-wide entity will not be under review unless a party specifically requests, or Commerce self-initiates, a review of the China-wide entity.<sup>15</sup> Because no party requested a review of the China-wide entity in this review, the China-wide entity is not under review and the China-wide entity's rate (*i.e.*, 183.36 percent) is not subject to change.<sup>16</sup> For additional information, see the Preliminary Decision Memorandum.

### Public Comment

In accordance with 19 CFR 351.309(c), case briefs or other written comments may be submitted to the Assistant Secretary for Enforcement and Compliance no later than 30 days after the date of publication of these preliminary results, unless the Secretary alters the time limit. Rebuttal briefs, limited to issues raised in case briefs, may be submitted no later than seven days after the deadline date for case

briefs.<sup>17</sup> Pursuant to 19 CFR 351.309(c)(2) and (d)(2), parties who submit case briefs or rebuttal briefs in this review are encouraged to submit with each argument: (1) A statement of the issue; (2) a brief summary of the argument; and (3) a table of authorities. Note that Commerce has temporarily modified certain of its requirements for serving documents containing business proprietary information, until further notice.<sup>18</sup>

Pursuant to 19 CFR 351.310(c), interested parties who wish to request a hearing, limited to issues raised in the case and rebuttal briefs, must submit a written request to the Assistant Secretary for Enforcement and Compliance, U.S. Department of Commerce, within 30 days after the date of publication of this notice. Requests should contain: (1) The party's name, address, and telephone number; (2) the number of participants; and (3) a list of issues to be discussed. Oral presentations at the hearing will be limited to those issues raised in the briefs. If a request for a hearing is made, Commerce intends to hold the hearing at a date and time to be determined.<sup>19</sup>

### Assessment Rates

Upon issuance of the final results of this review, Commerce will determine, and CBP shall assess, AD duties on all appropriate entries covered by this review.<sup>20</sup> We have not calculated any assessment rates in this administrative review. Based on record evidence, we have preliminarily determined that 17 companies had no shipments of subject merchandise and, therefore, pursuant to Commerce's assessment practice, any suspended entries that entered under their case numbers, where available, will be liquidated at the China-wide entity rate.<sup>21</sup> For all remaining companies subject to this review, which are part of the China-wide entity, we will instruct CBP to liquidate their entries at the current rate for the China-wide entity (*i.e.*, 183.36 percent). Commerce intends to issue assessment instructions to CBP no earlier than 35 days after the date of publication of the final results of this review in the **Federal Register**. If a timely summons is filed at the U.S. Court of International

Trade, the assessment instructions will direct CBP not to liquidate relevant entries until the time for parties to file a request for a statutory injunction has expired (*i.e.*, within 90 days of publication).

### Cash Deposit Requirements

The following cash deposit requirements will be effective upon publication of the final results of this administrative review for shipments of the subject merchandise from China entered, or withdrawn from warehouse, for consumption on or after the publication date of the final results of this administrative review, as provided by section 751(a)(2)(C) of the Act: (1) The cash deposit rates for the 17 companies that had no shipments during the POR will remain unchanged from the rates assigned to them in the most recently completed segment for each company; (2) for previously investigated or reviewed Chinese and non-Chinese exporters that have separate rates, the cash deposit rate will continue to be the exporter-specific rate published for the most recently completed segment of this proceeding; (3) for all Chinese exporters of subject merchandise that have not been found to be entitled to a separate rate, the cash deposit rate will be the rate for the China-wide entity (*i.e.*, 183.36 percent); and (4) for all non-Chinese exporters of subject merchandise that have not received their own rate, the cash deposit rate will be the rate applicable to the Chinese exporter that supplied that non-Chinese exporter. These deposit requirements, when imposed, shall remain in effect until further notice.

### Final Results of Review

Unless otherwise extended, Commerce intends to issue the final results of this administrative review, which will include the results of its analysis of issues raised in any briefs, within 120 days of publication of these preliminary results of review, pursuant to section 751(a)(3)(A) of the Act.

### Notification to Importers

This notice also serves as a reminder to importers of their responsibility under 19 CFR 351.402(f)(2) to file a certificate regarding the reimbursement of AD duties prior to liquidation of the relevant entries during this POR. Failure to comply with this requirement could result in Commerce's presumption that reimbursement of AD duties occurred and the subsequent assessment of double AD duties.

<sup>11</sup> See *Non-Market Economy Antidumping Proceedings: Assessment of Antidumping Duties*, 76 FR 65694, 65694–95 (October 24, 2011); see also "Assessment Rate" section below.

<sup>12</sup> See Appendix II.

<sup>13</sup> See Appendix I.

<sup>14</sup> See *Antidumping Proceedings: Announcement of Change in Department Practice for Respondent Selection in Antidumping Duty Proceedings and Conditional Review of the Nonmarket Economy Entity in NME Antidumping Duty Proceedings*, 78 FR 65963 (November 4, 2013).

<sup>15</sup> *Id.*

<sup>16</sup> See *Order*, 83 FR at 512.

<sup>17</sup> See 19 CFR 351.309; see also 19 CFR 351.303 (for general filing requirements).

<sup>18</sup> See *Temporary Rule Modifying AD/CVD Service Requirements Due to Covid-19, Extension of Effective Period*, 85 FR 41363 (July 10, 2020).

<sup>19</sup> See 19 CFR 351.310(d).

<sup>20</sup> See 19 CFR 351.212(b)(1).

<sup>21</sup> For a full discussion of this practice, see *Non-Market Economy Antidumping Proceedings: Assessment of Antidumping Duties*, 76 FR 65694 (October 24, 2011).

**Notification to Interested Parties**

These preliminary results of administrative review are issued and published in accordance with sections 751(a)(1) and 777(i)(1) of the Act, and 19 CFR 351.213(h)(1).

Dated: January 27, 2022.

**Lisa W. Wang,**

*Assistant Secretary for Enforcement and Compliance.*

**Appendix I****Companies Not Eligible for a Separate Rate**

1. Anhui Hoda Wood Co., Ltd.
2. China Friend Limited.
3. Deqing China-Africa Foreign Trade Port Co., Ltd.
4. Feixian Jinde Wood Factory
5. G.D. Enterprise Limited
6. Henan Hongda Woodcraft Industry Co., Ltd.
7. Jiangsu Qianjiuren International Trading Co., Ltd.
8. Jiangsu Shengyang Industrial Joint Stock Co., Ltd.
9. Jiashan Dalin Wood Industry Co., Ltd.
10. Jiaxing Kaochuan Woodwork Co., Ltd.
11. Leadwood Industrial Corp.
12. Linyi Chengen Import and Export Co., Ltd.
13. Linyi City Dongfang Fukai Wood Industry Co., Ltd.
14. Linyi City Shenrui International Trade Co., Ltd.
15. Linyi Tian He Wooden Industry Co., Ltd.
16. Pizhou Dayun Import & Export Trade Co., Ltd.
17. Pizhou Jin Sheng Yuan International Trade Co., Ltd.
18. Shandong Anxin Timber Co., Ltd.
19. Shandong Huaxin Jiasheng Wood Co., Ltd.
20. Shandong Huiyu International Trade Co., Ltd.
21. Shandong Johnson Trading Co., Ltd.
22. Shanghai S&M Trade Co., Ltd.
23. Smart Gift International
24. Suining Pengxiang Wood Co., Ltd.
25. Suqian Yaorun Trade Co., Ltd.
26. Suzhou Dongsheng Wood Co., Ltd.
27. Suzhou Oriental Dragon Import and Export Co., Ltd.
28. Xuzhou Baoqi Wood Product Co., Ltd.
29. Xuzhou Dilun Wood Co. Ltd.
30. Xuzhou Eastern Huatai International Trading Co., Ltd.
31. Xuzhou Hansun Import & Export Co. Ltd.
32. Xuzhou Jiangheng Wood Products Co., Ltd.
33. Xuzhou Maker's Mark Building Materials Co., Ltd.
34. Xuzhou Shenghe Wood Co. Ltd.
35. Xuzhou Shuiwangxing Trading Co., Ltd.
36. Xuzhou Shuner Import & Export Trade Co. Ltd.
37. Xuzhou Tianshan Wood Co., Ltd.
38. Xuzhou Timber International Trade Co., Ltd.
39. Yangzhou Hanov International Co., Ltd.

**Appendix II****Companies Preliminarily Found To Have No Shipments**

1. Celtic Co., Ltd.

2. Cosco Star International Co., Ltd.
3. Happy Wood Industrial Group Co., Ltd.
4. Jiaxing Hengtong Wood Co., Ltd.
5. Linyi Evergreen Wood Co., Ltd.
6. Linyi Glary Plywood Co., Ltd.
7. Linyi Huasheng Yongbin Wood Co., Ltd.
8. Linyi Jiahe Wood Industry Co., Ltd.
9. Linyi Sanfortune Wood Co., Ltd.
10. Qingdao Top P&Q International Corp.
11. Shandong Qishan International Trading Co., Ltd.
12. Shanghai Brightwood Trading Co., Ltd.
13. Shanghai Futuwood Trading Co., Ltd.
14. Shanghai Luli Trading Co., Ltd.
15. Suqian Hopeway International Trade Co., Ltd.
16. Xuzhou Jiangyang Wood Industries Co., Ltd.
17. Zhejiang Dehua TB Import & Export Co., Ltd.

**Appendix III****List of Topics Discussed in the Preliminary Decision Memorandum**

- I. Summary
- II. Background
- III. Scope of the Order
- IV. Discussion of the Methodology
- V. Recommendation

[FR Doc. 2022-02216 Filed 2-2-22; 8:45 am]

**BILLING CODE 3510-DS-P**

**DEPARTMENT OF COMMERCE****International Trade Administration****Extension of U.S. Section Member Appointments to the United States-Brazil CEO Forum**

**AGENCY:** International Trade Administration (ITA), Department of Commerce (DOC).

**ACTION:** Notice.

**SUMMARY:** The Secretary of Commerce and the Director of the National Economic Council are extending the current U.S. Section Member appointments of the United States-Brazil CEO Forum through April 30, 2022.

**ADDRESSES:** For inquiries, please contact Christopher Di Trolio, Office of Latin America and the Caribbean, U.S. Department of Commerce, by email at [Christopher.DiTrolio@trade.gov](mailto:Christopher.DiTrolio@trade.gov).

**FOR FURTHER INFORMATION CONTACT:** Christopher Di Trolio, 202-823-0530, Office of Latin America and the Caribbean, U.S. Department of Commerce. [Christopher.DiTrolio@trade.gov](mailto:Christopher.DiTrolio@trade.gov).

**SUPPLEMENTARY INFORMATION:** In March 2007, the Governments of the United States and Brazil established the U.S.-Brazil CEO Forum (Forum). Through a **Federal Register** notice on October 12, 2018 (83 FR 51663), the Department of Commerce solicited applicants for

appointment to the U.S. Section for a term of three years to expire November 30, 2021, and on December 21, 2018 (83 FR 65627), the term was extended through February 24, 2022. Vacancies arising during the three-year term were filled through the same process (see 83 FR 65627 (Dec. 21, 2018) and 86 FR 1479 (Jan. 8, 2021)). The Secretary of Commerce and the Director of the National Economic Council, together with the Brazilian Minister of Economy and the Planalto Casa Civil Minister (Presidential Chief of Staff), co-chair the U.S.-Brazil CEO Forum (Forum), pursuant to the Terms of Reference signed in March 2007 by the U.S. and Brazilian governments, as amended, which set forth the objectives and structure of the Forum. The Terms of Reference may be viewed at: <https://www.trade.gov/us-brazil-ceo-forum-terms-reference/>. The Forum, consisting of both private and public sector members, brings together leaders of the respective business communities of the United States and Brazil to discuss issues of mutual interest, particularly ways to strengthen the economic and commercial ties between the two countries. The Forum consists of the U.S. and Brazilian Government co-chairs and a Committee comprised of private sector members. The Committee is composed of two Sections, each consisting of approximately ten to twelve members from the private sector, representing the views and interests of the private sector business community in the United States and Brazil. Each government appoints the members to its respective Section. The Committee provides joint recommendations to the two governments that reflect private sector views, needs, and concerns regarding the creation of an economic environment in which their respective private sectors can partner, thrive, and enhance bilateral commercial ties to expand trade between the United States and Brazil.

As stated in the amended Terms of Reference, "members [of the Forum] normally are to serve three-year terms but may be reappointed." The current U.S. Section Member appointments expire on February 24, 2022. The COVID-19 pandemic has impacted the most recently scheduled meeting of the United States-Brazil CEO Forum, resulting in a need for additional time for the current U.S. Section Members to participate in ongoing events through April 2022. For that reason, the Secretary of Commerce and the Director of the National Economic Council have decided to extend the current U.S.

Section Member appointments through April 30, 2022.

Dated: January 25, 2022.

**Alexander Peacher,**

*Director for the Office of Latin America & the Caribbean.*

[FR Doc. 2022-01881 Filed 2-2-22; 8:45 am]

**BILLING CODE 3510-HE-P**

## DEPARTMENT OF COMMERCE

### International Trade Administration

[A-580-874]

#### Certain Steel Nails From the Republic of Korea: Final Results of Antidumping Duty Administrative Review; 2019-2020; Correction

**AGENCY:** Enforcement and Compliance, International Trade Administration, Department of Commerce.

**ACTION:** Notice; correction.

**SUMMARY:** The Department of Commerce (Commerce) published notice in the *Federal Register* of January 20, 2022, in which Commerce announced the final results of the 2019-2020 administrative review of the antidumping duty (AD) order on certain steel nails from the Republic of Korea (Korea). This notice was a duplicate for a notice published on January 19, 2022, in which Commerce announced the final results of the 2019-2020 administrative review of the AD order on certain steel nails from Korea.

**FOR FURTHER INFORMATION CONTACT:** Eva Kim, AD/CVD Operations, Office IV, Enforcement and Compliance, International Trade Administration, U.S. Department of Commerce, 1401 Constitution Avenue NW, Washington, DC 20230; telephone: (202) 482-8283.

#### SUPPLEMENTARY INFORMATION:

##### Correction

In the *Federal Register* of January 20, 2022, the FR Doc 2022-01038 is a duplicate to the notice published on January 19, 2022, FR Doc 2022-00957.

##### Background

On January 20, 2022, Commerce published in the *Federal Register* the final results of the 2019-2020 administrative reviews of the AD order on certain steel nails from Korea.<sup>1</sup> This was a duplicate notice from the January 19, 2022, notice published in the *Federal Register* announcing the final results of the 2019-2020 administrative

<sup>1</sup> See *Certain Steel Nails From the Republic of Korea: Final Results of Antidumping Duty Administrative Review; 2019-2020*, 87 FR 3079 (January 20, 2022).

reviews of the AD order on certain steel nails from Korea.<sup>2</sup> The controlling notice is the original January 19, 2022, notice. The inadvertent duplicate publication of this notice does not constitute redetermination of this proceeding. This notice serves as a notification of, and correction to, this inadvertent duplicate publication.

#### Notification to Interested Parties

This notice is issued and published in accordance with section 751(a) of the Tariff Act of 1930, as amended.

Dated: January 28, 2022.

**Lisa W. Wang,**

*Assistant Secretary for Enforcement and Compliance.*

[FR Doc. 2022-02274 Filed 2-2-22; 8:45 am]

**BILLING CODE 3510-DS-P**

## DEPARTMENT OF COMMERCE

### National Oceanic and Atmospheric Administration

[RTID 0648-XB769]

#### Mid-Atlantic Fishery Management Council (MAFMC); Public Meeting

**AGENCY:** National Marine Fisheries Service (NMFS), National Oceanic and Atmospheric Administration (NOAA), Commerce.

**ACTION:** Notice; public meeting.

**SUMMARY:** The Ecosystem and Ocean Planning (EOP) Committee and Advisory Panel (AP) of the Mid-Atlantic Fishery Management Council (Council) will hold a joint meeting. See **SUPPLEMENTARY INFORMATION** for agenda details.

**DATES:** The meeting will be held on Thursday, February 24, 2022, from 1 p.m. through 2:30 p.m.

**ADDRESSES:** The meeting will take place over webinar with a telephone-only connection option. Details on how to connect to the webinar by computer and by telephone will be available at: [www.mafmc.org](http://www.mafmc.org).

*Council address:* Mid-Atlantic Fishery Management Council, 800 N State Street, Suite 201, Dover, DE 19901; telephone: (302) 674-2331; website: [www.mafmc.org](http://www.mafmc.org).

**FOR FURTHER INFORMATION CONTACT:** Christopher M. Moore, Ph.D., Executive Director, Mid-Atlantic Fishery Management Council, telephone: (302) 526-5255.

<sup>2</sup> See *Certain Steel Nails From the Republic of Korea: Final Results of Antidumping Duty Administrative Review; 2019-2020*, 87 FR 2763 (January 19, 2022).

**SUPPLEMENTARY INFORMATION:** The purpose of this meeting is for the EOP Committee and AP to provide feedback and input on a research project the Council is collaborating on with a research team from Rutgers University. The project is developing forecast models to predict short-term (1-10 years) climate-induced distribution changes for four economically important Mid and South Atlantic managed species (summer flounder, spiny dogfish, Illex squid, and gray triggerfish). Short-term projections should provide for greater management utility and application since most management considerations and decisions operate at similar timescales. A forecast model has been completed for summer flounder and the research team will present on model development and initial/draft results and outputs. The EOP Committee and AP will provide feedback on the model outputs and their potential utility and offer input on future project direction and next steps.

A detailed agenda and background documents will be made available on the Council's website ([www.mafmc.org](http://www.mafmc.org)) prior to the meeting.

#### Special Accommodations

The meeting is physically accessible to people with disabilities. Requests for sign language interpretation or other auxiliary aid should be directed to Shelley Spedden, (302) 526-5251, at least 5 days prior to the meeting date.

*Authority:* 16 U.S.C. 1801 *et seq.*

Dated: January 31, 2022.

**Tracey L. Thompson,**

*Acting Deputy Director, Office of Sustainable Fisheries, National Marine Fisheries Service.*

[FR Doc. 2022-02285 Filed 2-2-22; 8:45 am]

**BILLING CODE 3510-22-P**

## DEPARTMENT OF COMMERCE

### National Oceanic and Atmospheric Administration

[RTID 0648-XB696]

#### Taking of Threatened or Endangered Marine Mammals Incidental to Commercial Fishing Operations; Issuance of Permit

**AGENCY:** National Marine Fisheries Service (NMFS), National Oceanic and Atmospheric Administration (NOAA), Commerce.

**ACTION:** Notice.

**SUMMARY:** The National Marine Fisheries Service (NMFS) is issuing a permit to authorize the incidental, but not intentional, take of specific

Endangered Species Act (ESA)-listed marine mammal species or stocks under the Marine Mammal Protection Act (MMPA), in the Alaska (AK) Bering Sea, Aleutian Islands (BSAI) Pacific cod pot fishery.

**DATES:** The permit is effective for a three-year period beginning February 3, 2022.

**ADDRESSES:** Reference materials for the permit including the final negligible impact determination are available on the internet at <https://www.fisheries.noaa.gov/action/negligible-impact-determination-and-mmpa-section-101a5e-authorization-ak-bering-sea-aleutian> or <https://www.regulations.gov/docket/NOAA-NMFS-2021-0123>. Other supporting information is available on the internet including: Recovery plans for the ESA-listed marine mammal species, <https://www.fisheries.noaa.gov/national/endangered-species-conservation/recovery-species-under-endangered-species-act>; 2021 MMPA List of Fisheries (LOF), <https://www.fisheries.noaa.gov/national/marine-mammal-protection/list-fisheries-summary-tables>; the most recent Marine Mammal Stock Assessment Reports (SAR) by region, <https://www.fisheries.noaa.gov/national/marine-mammal-protection/marine-mammal-stock-assessment-reports-region>, and stock, <https://www.fisheries.noaa.gov/national/marine-mammal-protection/marine-mammal-stock-assessment-reports-species-stock>; and Take Reduction Teams and Plans, <https://www.fisheries.noaa.gov/national/marine-mammal-protection/marine-mammal-take-reduction-plans-and-teams>.

**FOR FURTHER INFORMATION CONTACT:** Suzie Teerlink, NMFS Alaska Region, 907-586-7240, [Suzie.Teerlink@noaa.gov](mailto:Suzie.Teerlink@noaa.gov); or Jaclyn Taylor, NMFS Office of Protected Resources, 301-427-8402, [Jaclyn.Taylor@noaa.gov](mailto:Jaclyn.Taylor@noaa.gov).

**SUPPLEMENTARY INFORMATION:** The MMPA requires NMFS to authorize the incidental take of ESA-listed marine mammals in commercial fisheries provided it can make the following determinations: (1) The incidental mortality and serious injury (M/SI) from commercial fisheries will have a negligible impact on the affected species or stocks; (2) a recovery plan for all affected species or stocks of threatened or endangered marine mammals has been developed or is being developed; and (3) where required under MMPA section 118, a take reduction plan has been developed or is being developed, a monitoring program is implemented, and vessels participating in the fishery are registered (16 U.S.C. 1371(a)(5)(E)).

NMFS has determined that the AK BSAI Pacific cod pot fishery meets these three requirements and is issuing a permit to the fishery to authorize the incidental take of ESA-listed marine mammal species or stocks (Central North Pacific and Western North Pacific stocks of humpback whale) under the MMPA for a period of three years.

### Background

The MMPA List of Fisheries (LOF) classifies each commercial fishery as a Category I, II, or III fishery based on the level of mortality and injury of marine mammals occurring incidental to each fishery as defined in 50 CFR 229.2. Category I and II fisheries must register with NMFS and are subsequently authorized to incidentally take marine mammals during commercial fishing operations. However, that authorization is limited to those marine mammals that are not listed as threatened or endangered under the ESA. Section 101(a)(5)(E) of the MMPA, 16 U.S.C. 1371, states that NMFS, as delegated by the Secretary of Commerce, for a period of up to 3 years shall allow the incidental, but not intentional, taking of marine mammal stocks designated as depleted because of their listing as an endangered species or threatened species under the ESA, 16 U.S.C. 1531 *et seq.*, by persons using vessels of the United States and those vessels which have valid fishing permits issued by the Secretary in accordance with section 204(b) of the Magnuson-Stevens Fishery Conservation and Management Act, 16 U.S.C. 1824(b), while engaging in commercial fishing operations, if NMFS makes certain determinations. NMFS must determine, after notice and opportunity for public comment, that: (1) Incidental M/SI from commercial fisheries will have a negligible impact on the affected species or stock; (2) a recovery plan has been developed or is being developed for such species or stock under the ESA; and (3) where required under section 118 of the MMPA, a monitoring program has been established, vessels engaged in such fisheries are registered in accordance with section 118 of the MMPA, and a take reduction plan has been developed or is being developed for such species or stock.

The LOF includes a list of marine mammal species or stocks incidentally killed or injured in each commercial fishery. We evaluated ESA-listed stocks or species included on the final 2021 MMPA LOF as killed or seriously injured following NMFS' Procedural Directive 02-238 "Process for Distinguishing Serious from Non-Serious Injury of Marine Mammals."

Based on this evaluation, NMFS proposed to issue a permit under MMPA section 101(a)(5)(E) to vessels registered in the Category II AK BSAI Pacific cod pot fishery, as classified on the final 2021 MMPA LOF, to incidentally kill or seriously injure individuals from the Central North Pacific and Western North Pacific stocks of humpback whale (86 FR 71236; December 15, 2021).

NMFS will regularly evaluate other commercial fisheries for purposes of making a negligible impact determination (NID) and issuing section 101(a)(5)(E) authorizations with the annual LOF as new information becomes available. More information about the AK BSAI Pacific cod pot fishery is available in the 2021 MMPA LOF (86 FR 3028; January 14, 2021) and on the internet at: <https://www.fisheries.noaa.gov/national/marine-mammal-protection/list-fisheries-summary-tables>.

We reviewed the best available scientific information to determine whether the AK BSAI Pacific cod pot fishery met the three requirements of MMPA section 101(a)(5)(E) for issuing a permit for the incidental taking of ESA-listed marine mammals. This information is included in the 2021 MMPA LOF (86 FR 3028; January 14, 2021), the SARs for these species (available at: <https://www.fisheries.noaa.gov/national/marine-mammal-protection/marine-mammal-stock-assessment-reports>), recovery plans for these species (available at: <https://www.fisheries.noaa.gov/national/endangered-species-conservation/recovery-species-under-endangered-species-act>), and other relevant information, as detailed further in the documents describing the preliminary and final determinations supporting the permit (available at: <https://www.regulations.gov/docket/NOAA-NMFS-2021-0123>).

NMFS is in the process of revising humpback whale stock structure under the MMPA in response to the 14 Distinct Population Segments (DPSs) established under the ESA (81 FR 62259, September 8, 2016), and based on the "Procedural Directive 02-204-03: Reviewing and Designating Stocks and Issuing Stock Assessment Reports under the Marine Mammal Protection Act" (NMFS 2019). The humpback whale DPSs that occur in waters under the jurisdiction of the United States do not align with the existing MMPA stocks. Some of the listed DPSs partially coincide with the currently defined stocks. Because we cannot manage one portion of an MMPA stock as ESA-listed and another portion of a stock as not ESA-listed, until such time as the

MMPA stock designations are revised, NMFS continues to use the existing MMPA stock structure for MMPA management purposes (*e.g.*, selection of a recovery factor, stock status) and treats such stocks as ESA-listed if a component of that stock is listed under the Act and overlaps with the analyzed commercial fishery. Therefore, for the purpose of this MMPA 101(a)(5)(E) authorization, we considered the Central North Pacific and Western North Pacific stocks of humpback whales to be ESA-listed as they overlap with the two ESA-listed DPSs: The threatened Mexico DPS and the endangered Western North Pacific DPS.

#### Basis for Determining Negligible Impact

Prior to issuing a MMPA 101(a)(5)(E) permit to take ESA-listed marine mammals incidental to commercial fishing, NMFS must determine if the M/SI incidental to commercial fisheries will have a negligible impact on the affected marine mammal species or stocks. NMFS satisfies this requirement by making a NID. Although the MMPA does not define “negligible impact,” NMFS has issued regulations providing a qualitative definition of “negligible impact,” defined in 50 CFR 216.103, as an impact resulting from the specified activity that cannot be reasonably expected to, and is not reasonably likely to, adversely affect the species or stock through effects on annual rates of recruitment or survival.

#### Criteria for Determining Negligible Impact

NMFS relies on a quantitative approach for determining negligible impact detailed in NMFS Procedural Directive 02–204–02 (directive), “Criteria for Determining Negligible Impact under MMPA section 101(a)(5)(E),” which became effective on June 17, 2020 (NMFS 2020). The procedural directive is available online at: <https://www.fisheries.noaa.gov/national/laws-and-policies/protected-resources-policy-directives>. The directive describes NMFS’ process for determining whether incidental M/SI from commercial fisheries will have a negligible impact on ESA-listed marine mammal species/stocks (the first requirement necessary for issuing a MMPA section 101(a)(5)(E) permit as noted above).

The directive first describes the derivation of two Negligible Impact Thresholds (NIT), which represent levels of removal from a marine mammal species or stock. The first, Total Negligible Impact Threshold (NIT<sub>t</sub>), represents the total amount of human-caused M/SI that NMFS

considers negligible for a given stock. The second, lower threshold, Single NIT (NIT<sub>s</sub>) represents the level of M/SI from a single commercial fishery that NMFS considers negligible for a stock. NIT<sub>s</sub> was developed in recognition that some stocks may experience non-negligible levels of total human-caused M/SI but one or more individual fisheries may contribute a very small portion of that M/SI, and the effect of an individual fishery may be considered negligible.

The directive describes a detailed process for using these NIT values to conduct a NID analysis for each fishery classified as a Category I or II fishery on the MMPA LOF. The NID process uses a two-tiered analysis. The Tier 1 analysis first compares the total human-caused M/SI for a particular stock to NIT<sub>t</sub>. If NIT<sub>t</sub> is not exceeded, then all commercial fisheries that kill or seriously injure the stock are determined to have a negligible impact on the particular stock. If NIT<sub>t</sub> is exceeded, then the Tier 2 analysis compares each individual fishery’s M/SI for a particular stock to NIT<sub>s</sub>. If NIT<sub>s</sub> is not exceeded, then the commercial fishery is determined to have a negligible impact on that particular stock. For transboundary, migratory stocks, because of the uncertainty regarding the M/SI that occurs outside of U.S. waters, we assume that total M/SI exceeds NIT<sub>t</sub> and proceed directly to the Tier 2 NIT<sub>s</sub> analysis. If a commercial fishery has a negligible impact across all ESA-listed stocks, then the first of 3 findings necessary for issuing a MMPA 101(a)(5)(E) permit to the commercial fishery has been met (*i.e.*, a negligible impact determination). If a commercial fishery has a non-negligible impact on any ESA-listed stock, then NMFS cannot issue a MMPA 101(a)(5)(E) permit for the fishery to incidentally take ESA-listed marine mammals.

These NID criteria rely on the best available scientific information, including estimates of a stock’s minimum population size and human-caused M/SI levels, as published in the most recent SARs and other supporting documents, as appropriate. Using these inputs, the quantitative negligible impact thresholds allow for straightforward calculations that lead to clear negligible or non-negligible impact determinations for each commercial fishery analyzed. In rare cases, robust data may be unavailable for a straightforward calculation, and the directive provides instructions for completing alternative calculations or assessments where appropriate.

#### Negligible Impact Determination

NMFS evaluated the impact of the AK BSAI Pacific cod pot fishery using the process outlined in the directive, and, based on the best available scientific information, made a NID.

The Central North Pacific and Western North Pacific stocks of humpback whales are transboundary stocks. As noted above, because of the uncertainty regarding M/SI that occurs outside of U.S. waters for transboundary stocks, we assumed that total M/SI exceeds NIT<sub>t</sub> and proceeded directly to the Tier 2 NIT<sub>s</sub> analysis. The most recent (2020) final Central North Pacific and Western North Pacific humpback whale SARs documented M/SI of Central North Pacific and Western North Pacific stocks of humpback whale incidental to this fishery (Muto *et al.* 2021).

The estimated annual M/SI of Central North Pacific humpback whales in the AK BSAI Pacific cod pot fishery is 0.2, based on Alaska Marine Mammal Health and Stranding Response Program data. Since this M/SI (0.2) is less than NIT<sub>s</sub> (3.59), NMFS determined that the AK BSAI Pacific cod pot fishery has a negligible impact on the Central North Pacific stock of humpback whales (see accompanying MMPA 101(a)(5)(E) determination document linked above for NIT calculations).

The estimated annual M/SI of Western North Pacific humpback whales in the AK BSAI Pacific cod pot fishery is 0.2, based on Alaska Marine Mammal Health and Stranding Response Program data. Since this M/SI (0.2) is less than NIT<sub>s</sub> (0.39), NMFS determined that the AK BSAI Pacific cod pot fishery has a negligible impact on the Western North Pacific stock of humpback whales (see accompanying MMPA 101(a)(5)(E) determination document linked above for NIT calculations).

The estimated annual M/SI noted above for the Central North Pacific and Western North Pacific stocks of humpback whales is based on a single M/SI event that occurred in an area where the two stocks overlap. This M/SI was assigned to both the Central North Pacific and Western North Pacific stocks (Muto *et al.* 2021) and was therefore included in the NID analysis for each of these stocks. This is conservative as it double counts this single M/SI event and assumes it applies to each stock individually. Furthermore, this also conservatively assumes that this M/SI necessarily involved a humpback that is listed under the ESA, despite a large portion (approximately 91 percent) of the

humpback whales in the Aleutian Islands, Bering Sea, Chukchi Sea, and Beaufort Sea area estimated to be part of the Hawaii DPS, which is not listed under the ESA (Wade 2021, NMFS 2021). However, as discussed above, the humpback whale MMPA stock designations are currently being revised in response to the ESA-listed DPSs. In revising humpback stocks, NMFS is evaluating the available data and methods to apportion the M/SI to the individual stocks in areas where they overlap. Once the revised stock designations are finalized and the M/SI for those stocks is analyzed, the MMPA 101(a)(5)(E) authorization will be modified as appropriate.

The 2020 SAR includes the mean annual total commercial fishery-related M/SI (9.8) for the Central North Pacific stock of humpback whale and (0.9) for the Western North Pacific stock of humpback whale. This comprises M/SI from all commercial fisheries, including the AK BSAI Pacific cod pot fishery, as well as fishery-related M/SI for the stock not assigned to a specific commercial fishery. The SARs for both stocks also include unattributed fishery-related M/SI (7.9 for Central North Pacific, 0.4 for Western North Pacific), which is not assigned to a specific commercial fishery. This unattributed fishery-related M/SI could be from any number of commercial or recreational fisheries, including the AK BSAI Pacific cod pot fishery. In accordance with NMFS Procedural Directive 02–204–02, because data are not currently available to assign the unattributed fishery-related M/SI to a specific commercial fishery, we did not include unattributed mortality in the calculations for the NID Tier 2 analysis (NMFS 2020).

In addition, because the Central North Pacific and Western North Pacific stocks of humpback whales are considered to be transboundary stocks, NMFS assumed  $NIT_1$  is exceeded and conducted the more conservative Tier 2 analysis with the lower  $NIT_5$  criterion. NMFS is actively monitoring the AK BSAI Pacific cod pot fishery through the North Pacific Fisheries Observer Program. Further, most of the information on large whale entanglements in Alaska is reported to and documented by the Alaska Large Whale Entanglement Response Program. If additional fishery-related M/SI of the Central North Pacific or Western North Pacific stock of humpback whale is documented through the observer program or the Alaska Marine Mammal Health and Stranding Response Program that indicates additional M/SI of the Central North Pacific or Western North Pacific stock of humpback whale in the

AK BSAI Pacific cod pot fishery, then NMFS will re-evaluate the NID and the permit.

The NID analysis is presented in an accompanying MMPA section 101(a)(5)(E) determination document that provides summaries of the information used to evaluate each ESA-listed stocks documented on the 2021 MMPA LOF as killed or injured incidental to the fishery (available at: <https://www.fisheries.noaa.gov/action/mmpa-list-fisheries-2021>). The final MMPA 101(a)(5)(E) determination document is available at: <https://www.fisheries.noaa.gov/action/negligible-impact-determination-and-mmpa-section-101a5e-authorization-ak-bering-sea-aleutian> or <https://www.regulations.gov/docket/NOAA-NMFS-2021-0123>. Based on the criteria outlined in the directive, the most recent SAR, and the best available scientific information, NMFS has determined that the M/SI incidental to the Category II AK BSAI Pacific cod pot fishery will have a negligible impact on the associated ESA-listed marine mammal stocks (Central North Pacific and Western North Pacific stocks of humpback whale). Accordingly, this MMPA 101(a)(5)(E) requirement is satisfied for the commercial fishery (see MMPA 101(a)(5)(E) determination document available at: <https://www.regulations.gov/docket/NOAA-NMFS-2021-0123>).

#### Recovery Plan

The humpback whale recovery plan has been completed (see <https://www.fisheries.noaa.gov/national/endangered-species-conservation/recovery-species-under-endangered-species-act>). Accordingly, the requirement to have recovery plans in place or being developed is satisfied.

#### Take Reduction Plan

Subject to available funding, MMPA section 118 requires the development and implementation of a Take Reduction Plan (TRP) for each strategic stock that interacts with a Category I or II fishery. The stocks considered for this permit are designated as a strategic stock under the MMPA because the stocks, or a component of the stocks, are listed as threatened or endangered under the ESA (MMPA section 3(19)(C)).

The short- and long-term goals of a TRP are to reduce M/SI of marine mammals incidental to commercial fishing to levels below the Potential Biological Removal (PBR) level for stocks and to an insignificant threshold, defined by NMFS as 10 percent of PBR, respectively. The obligations to develop

and implement a TRP are subject to the availability of funding. MMPA section 118(f)(3) (16 U.S.C. 1387(f)(3)) contains specific priorities for developing TRPs when funding is insufficient. NMFS has insufficient funding available to simultaneously develop and implement TRPs for all strategic stocks that interact with Category I or Category II fisheries. As provided in MMPA section 118(f)(6)(A) and (f)(7), NMFS uses the most recent SAR and LOF as the basis to determine its priorities for establishing Take Reduction Teams (TRT) and developing TRPs. Information about NMFS' marine mammal TRTs and TRPs may be found at: <https://www.fisheries.noaa.gov/national/marine-mammal-protection/marine-mammal-take-reduction-plans-and-teams>.

Based on NMFS' priorities, implementation of a TRP for the AK BSAI Pacific cod pot fishery is currently deferred under MMPA section 118 as other stocks/fisheries are a higher priority for any available funding. Accordingly, the requirement under MMPA section 118 to have TRPs in place or in development is satisfied (see determination supporting the permit available on the internet at <https://www.regulations.gov/docket/NOAA-NMFS-2021-0123>).

#### Monitoring Program

Under MMPA section 118(d), NMFS is to establish a program for monitoring incidental M/SI of marine mammals from commercial fishing operations. The AK BSAI Pacific cod pot fishery is monitored under the partial coverage category through the North Pacific Fisheries Observer Program. Accordingly, the requirement under MMPA section 118 to have a monitoring program in place is satisfied.

#### Vessel Registration

MMPA section 118(c) requires that vessels participating in Category I and II fisheries register to obtain an authorization to take marine mammals incidental to fishing activities. NMFS has integrated the MMPA registration process, implemented through the Marine Mammal Authorization Program, with existing state and Federal fishery license, registration, or permit systems for Category I and II fisheries on the LOF. Therefore, the requirement for vessel registration is satisfied.

#### Conclusions for Proposed Permit

Based on the above evaluation for the AK BSAI Pacific cod pot fishery as it relates to the three requirements of MMPA section 101(a)(5)(E), we are issuing a MMPA 101(a)(5)(E) permit to

the AK BSAI Pacific cod pot fishery to authorize the incidental take of ESA-listed species or stocks during commercial fishing operations. If, during the three-year authorization, there is a significant change in the information or conditions used to support any of these determinations, NMFS will re-evaluate whether to amend or modify the authorization, after notice and opportunity for public comment.

### ESA Section 7 and National Environmental Policy Act Requirements

ESA section 7(a)(2) requires federal agencies to ensure that actions they authorize, fund, or carry out do not jeopardize the existence of any species listed under the ESA, or destroy or adversely modify designated critical habitat of any ESA-listed species. The effects of the AK BSAI Pacific cod pot fishery on ESA-listed marine mammals, were analyzed in the ESA section 7 Biological Opinion for the BSAI Groundfish Fishery Management Plan.

Under section 7 of the ESA, Biological Opinions analyze the effects of the proposed action on ESA-listed species and their critical habitat and, where appropriate, exempt anticipated future take of ESA-listed species as specified in the incidental take statement. Under MMPA section 101(a)(5)(E), NMFS analyzes previously documented M/SI incidental to commercial fisheries through the negligible impact determination process, and when the necessary findings can be made, issues a MMPA section 101(a)(5)(E) permit that allows for an unspecified amount of incidental taking of specific ESA-listed marine mammal stocks while engaging in commercial fishing operations. Thus, the applicable standards and resulting analyses under the MMPA and ESA differ, and as such, may not always align.

The National Environmental Policy Act (NEPA) requires Federal agencies to evaluate the impacts of alternatives for their actions on the human environment. Because the permit would not modify any fishery operation and the effects of the fishery operations have been evaluated in accordance with NEPA, no additional NEPA analysis beyond that conducted for the associated Fishery Management Plan is required for the permit. Issuing the permit would have no additional impact on the human environment or effects on threatened or endangered species beyond those analyzed in these documents.

### Public Comments

On December 15, 2021, NMFS published a notice and request for comments in the **Federal Register** for the proposed issuance of a permit under MMPA section 101(a)(5)(E) to vessels registered in the Category II AK BSAI Pacific cod pot fishery (86 FR 71236). The public comment period closed on December 30, 2021. NMFS received one non-substantive comment letter opposing the proposed issuance of the permit and underlying preliminary negligible impact determination.

### References

- Muto, M.M., V.T. Helker, B.J. Delean, N.C. Young, J.C. Freed, R.P. Angliss, N.A. Friday, P.L. Boveng, J.M. Breiwick, B.M. Brost, M.F. Cameron, P.J. Clapham, J.L. Crance, S.P. Dahle, M.E. Dahlheim, B.S. Fadely, M.C. Ferguson, L.W. Fritz, K.T. Goetz, R.C. Hobbs, Y.V. Ivashchenko, A.S. Kennedy, J.M. London, S.A. Mizroch, R.R. Ream, E.L. Richmond, K.E. W. Shelden, K.L. Sweeney, R.G. Towell, P.R. Wade, J.M. Waite, and A.N. Zerbin. 2021. Alaska marine mammal stock assessments, 2020. U.S. Department of Commerce, NOAA Tech. Memo. NMFS–AFSC–421. 398 p.
- National Marine Fisheries Service (NMFS). 2021. Occurrence of Endangered Species Act (ESA) Listed Humpback Whales off Alaska. 4 p. Available online: <https://media.fisheries.noaa.gov/2021-12/Guidance-Humpbacks-Alaska.pdf>.
- National Marine Fisheries Service (NMFS). 2020. National Marine Fisheries Service Procedure 02–204–02: Criteria for Determining Negligible Impact under MMPA Section 101(a)(5)(E). 20 p. Available online: <https://www.fisheries.noaa.gov/national/laws-and-policies/protected-resources-policy-directives>.
- National Marine Fisheries Service (NMFS). 2019. National Marine Fisheries Service Procedure 02–204–03: Reviewing and Designating Stocks and Issuing Stock Assessment Reports under the Marine Mammal Protection Act. 9 p. Available online: <https://www.fisheries.noaa.gov/national/laws-and-policies/protected-resources-policy-directives>.
- National Marine Fisheries Service (NMFS). 2016. National Marine Fisheries Service Procedure 02–204–01: Guidelines for preparing stock assessment reports pursuant to the 1994 amendments to the Marine Mammal Protection Act. 23 p. Available online: <https://www.fisheries.noaa.gov/national/marine-mammal-protection/guidelines-assessing-marine-mammal-stocks>.
- National Marine Fisheries Service (NMFS). 2014. National Marine Fisheries Service Procedure 02–238–01: Process for Distinguishing Serious from Non-Serious Injury of Marine Mammals. 42 p. Available online: <https://www.fisheries.noaa.gov/national/marine-mammal-protection/marine-mammal-protection-act-policies-guidance-and-regulations>
- Wade, P. R. 2021. Estimates of abundance

and migratory destination for North Pacific humpback whales in both summer feeding areas and winter mating and calving areas. International Whaling Commission. SC/68c/IA/03. 32 p. <https://archive.iwc.int/>.

Dated: January 28, 2022.

**Kimberly Damon-Randall,**

*Director, Office of Protected Resources, National Marine Fisheries Service.*

[FR Doc. 2022–02166 Filed 2–2–22; 8:45 am]

**BILLING CODE 3510–22–P**

## DEPARTMENT OF COMMERCE

### National Oceanic and Atmospheric Administration

[RTID 0648–XB776]

### Pacific Fishery Management Council; Public Meeting

**AGENCY:** National Marine Fisheries Service (NMFS), National Oceanic and Atmospheric Administration (NOAA), Commerce.

**ACTION:** Notice of public meeting.

**SUMMARY:** The Pacific Fishery Management Council’s (Pacific Council) Ad Hoc Groundfish Electronic Monitoring Policy Advisory Committee and Technical Advisory Committee (Committees) will hold two webinars, which are open to the public.

**DATES:** The online meetings will be held February 23 and March 30, 2022, from 9 a.m. to 12 p.m., Pacific Time each day or until work for the day is completed.

**ADDRESSES:** These meetings will be held online. Specific meeting information, including directions on how to join the meetings and system requirements will be provided in the meeting announcements on the Pacific Council’s website (see [www.pcouncil.org](http://www.pcouncil.org)). You may send an email to Mr. Kris Kleinschmidt ([kris.kleinschmidt@noaa.gov](mailto:kris.kleinschmidt@noaa.gov)) or contact him at (503) 820–2412 for technical assistance.

*Council address:* Pacific Fishery Management Council, 7700 NE Ambassador Place, Suite 101, Portland, OR 97220–1384.

**FOR FURTHER INFORMATION CONTACT:** Brett Wiedoff, Staff Officer, Pacific Council; telephone: (503) 820–2424.

**SUPPLEMENTARY INFORMATION:** The purpose of these webinars is to discuss continued development of the West Coast Electronic Monitoring Program (EM Program). The Committees will begin scoping EM Program issues and conduct a workload planning process to identify future meetings and topics at the February 23rd webinar. The March 30th webinar will be a work session to

discuss meeting materials and topics that will be presented at the April 2022 Council meeting.

Although non-emergency issues not contained in the meeting agenda may be discussed, those issues may not be the subject of formal action during this meeting. Action will be restricted to those issues specifically listed in this document and any issues arising after publication of this document that require emergency action under section 305(c) of the Magnuson-Stevens Fishery Conservation and Management Act, provided the public has been notified of the intent to take final action to address the emergency.

#### Special Accommodations

Requests for sign language interpretation or other auxiliary aids should be directed to Mr. Kris Kleinschmidt ([kris.kleinschmidt@noaa.gov](mailto:kris.kleinschmidt@noaa.gov); (503) 820-2412) at least 10 days prior to the meeting date.

*Authority:* 16 U.S.C. 1801 *et seq.*

Dated: January 31, 2022.

**Tracey L. Thompson,**

*Acting Deputy Director, Office of Sustainable Fisheries, National Marine Fisheries Service.*

[FR Doc. 2022-02288 Filed 2-2-22; 8:45 am]

BILLING CODE 3510-22-P

## DEPARTMENT OF COMMERCE

### National Oceanic and Atmospheric Administration

[RTID 0648-XB764]

#### Takes of Marine Mammals Incidental to Specified Activities; Taking Marine Mammals Incidental to U.S. Navy Construction at Naval Station Newport, Rhode Island

**AGENCY:** National Marine Fisheries Service (NMFS), National Oceanic and Atmospheric Administration (NOAA), Commerce.

**ACTION:** Notice of issuance of letter of authorization.

**SUMMARY:** In accordance with the Marine Mammal Protection Act (MMPA), as amended, and implementing regulations, notification is hereby given that a Letter of Authorization (LOA) has been issued to the U.S. Navy (Navy) for the take of marine mammals incidental to construction activities at Naval Station Newport, in Newport, Rhode Island.

**DATES:** LOA effective from May 15, 2022 through May 14, 2027.

**ADDRESSES:** The LOA and supporting documentation are available online at: <https://www.fisheries.noaa.gov/action/>

*incidental-take-authorization-us-navy-construction-naval-station-newport-rhode-island.* In case of problems accessing these documents, please call the contact listed below (see **FOR FURTHER INFORMATION CONTACT**).

**FOR FURTHER INFORMATION CONTACT:** Stephanie Egger, Office of Protected Resources, NMFS, (301) 427-8401.

#### SUPPLEMENTARY INFORMATION:

##### Background

Sections 101(a)(5)(A) and (D) of the MMPA (16 U.S.C. 1361 *et seq.*) direct the Secretary of Commerce to allow, upon request, the incidental, but not intentional, taking of small numbers of marine mammals by U.S. citizens who engage in a specified activity (other than commercial fishing) within a specified geographical region if certain findings are made and either regulations are issued or, if the taking is limited to harassment, a notice of a proposed authorization is provided to the public for review.

An authorization for incidental takings shall be granted if NMFS finds that the taking will have a negligible impact on the species or stock(s), will not have an unmitigable adverse impact on the availability of the species or stock(s) for subsistence uses (where relevant), and if the permissible methods of taking and requirements pertaining to the mitigation, monitoring and reporting of such takings are set forth. NMFS has defined “negligible impact” in 50 CFR 216.103 as an impact resulting from the specified activity that cannot be reasonably expected to, and is not reasonably likely to, adversely affect the species or stock through effects on annual rates of recruitment or survival.

Except with respect to certain activities not pertinent here, the MMPA defines “harassment” as: any act of pursuit, torment, or annoyance which (i) has the potential to injure a marine mammal or marine mammal stock in the wild (Level A harassment); or (ii) has the potential to disturb a marine mammal or marine mammal stock in the wild by causing disruption of behavioral patterns, including, but not limited to, migration, breathing, nursing, breeding, feeding, or sheltering (Level B harassment).

##### Summary of Request

On December 15, 2021, we issued a final rule upon request from the Navy for authorization to take marine mammals incidental to construction activities (86 FR 71162). The Navy plans to conduct construction activities for bulkhead replacement and repairs at Naval Station Newport. This

construction will include use of vibratory pile driving and removal, and impact pile driving. The use of both vibratory and impact pile driving is expected to produce underwater sound at levels that have the potential to result in Level A and Level B harassment of marine mammals.

#### Authorization

We have issued a LOA to Navy authorizing the take of marine mammals incidental to construction activities, as described above. Take of marine mammals will be minimized through the implementation of the following planned mitigation measures: (1) Required monitoring of the construction area to detect the presence of marine mammals before beginning construction activities; (2) shutdown of construction activities under certain circumstances to avoid injury of marine mammals; and (3) soft start for impact pile driving to allow marine mammals the opportunity to leave the area prior to beginning impact pile driving at full power. Additionally, the rule includes an adaptive management component that allows for timely modification of mitigation or monitoring measures based on new information, when appropriate. The Navy will submit reports as required.

Based on these findings and the information discussed in the preamble to the final rule, the activities described under this LOA will have a negligible impact on marine mammal stocks and will not have an unmitigable adverse impact on the availability of the affected marine mammal stock for subsistence uses.

Dated: January 28, 2022.

**Kimberly Damon-Randall,**

*Director, Office of Protected Resources, National Marine Fisheries Service.*

[FR Doc. 2022-02164 Filed 2-2-22; 8:45 am]

BILLING CODE 3510-22-P

## DEPARTMENT OF COMMERCE

### National Oceanic and Atmospheric Administration

[RTID 0648-XB768]

#### Fisheries of the Gulf of Mexico; Southeast Data, Assessment, and Review (SEDAR); Public Meeting

**AGENCY:** National Marine Fisheries Service (NMFS), National Oceanic and Atmospheric Administration (NOAA), Commerce.

**ACTION:** Notice of SEDAR 68OA Life History Topical Working Group data



scoping webinar for Gulf of Mexico scamp grouper.

**SUMMARY:** The SEDAR 680A assessment of Gulf of Mexico scamp grouper will consist of a series of assessment webinars. See **SUPPLEMENTARY INFORMATION**.

**DATES:** The SEDAR 680A scoping webinar for the Life History Topical Working Group will be held February 24, 2022, from 1 p.m. to 3 p.m. Eastern. The established times may be adjusted as necessary to accommodate the timely completion of discussion relevant to the assessment process. Such adjustments may result in the meeting being extended from or completed prior to the time established by this notice.

**ADDRESSES:**

*Meeting address:* The meeting will be held via webinar. The webinar is open to members of the public. Those interested in participating should contact Julie A. Neer at SEDAR (see **FOR FURTHER INFORMATION CONTACT**) to request an invitation providing webinar access information. Please request webinar invitations at least 24 hours in advance of each webinar.

*SEDAR address:* 4055 Faber Place Drive, Suite 201, North Charleston, SC 29405.

**FOR FURTHER INFORMATION CONTACT:** Julie A. Neer, SEDAR Coordinator; (843) 571-4366; email: [Julie.neer@safmc.net](mailto:Julie.neer@safmc.net).

**SUPPLEMENTARY INFORMATION:** The Gulf of Mexico, South Atlantic, and Caribbean Fishery Management Councils, in conjunction with NOAA Fisheries and the Atlantic and Gulf States Marine Fisheries Commissions have implemented the Southeast Data, Assessment and Review (SEDAR) process, a multi-step method for determining the status of fish stocks in the Southeast Region. SEDAR is a multi-step process including: (1) Data Workshop; (2) Assessment Process utilizing webinars; and (3) Review Workshop. The product of the Data Workshop is a data report that compiles and evaluates potential datasets and recommends which datasets are appropriate for assessment analyses. The product of the Assessment Process is a stock assessment report that describes the fisheries, evaluates the status of the stock, estimates biological benchmarks, projects future population conditions, and recommends research and monitoring needs. The assessment is independently peer reviewed at the Review Workshop. The product of the Review Workshop is a Summary documenting panel opinions regarding the strengths and weaknesses of the stock assessment and input data.

Participants for SEDAR Workshops are appointed by the Gulf of Mexico, South Atlantic, and Caribbean Fishery Management Councils and NOAA Fisheries Southeast Regional Office, HMS Management Division, and Southeast Fisheries Science Center. Participants include data collectors and database managers; stock assessment scientists, biologists, and researchers; constituency representatives including fishermen, environmentalists, and NGO's; International experts; and staff of Councils, Commissions, and state and federal agencies.

The items of discussion in the data scoping webinar is as follows:

Participants will discuss what life history data may be available for use in the Operational Assessment of Gulf of Mexico scamp grouper.

Although non-emergency issues not contained in this agenda may come before this group for discussion, those issues may not be the subject of formal action during this meeting. Action will be restricted to those issues specifically identified in this notice and any issues arising after publication of this notice that require emergency action under section 305(c) of the Magnuson-Stevens Fishery Conservation and Management Act, provided the public has been notified of the intent to take final action to address the emergency.

**Special Accommodations**

The meeting is physically accessible to people with disabilities. Requests for sign language interpretation or other auxiliary aids should be directed to the Council office (see **ADDRESSES**) at least 5 business days prior to each webinar.

*Note:* The times and sequence specified in this agenda are subject to change.

*Authority:* 16 U.S.C. 1801 *et seq.*

Dated: January 31, 2022.

**Tracey L. Thompson,**

*Acting Deputy Director, Office of Sustainable Fisheries, National Marine Fisheries Service.*

[FR Doc. 2022-02286 Filed 2-2-22; 8:45 am]

**BILLING CODE 3510-22-P**

**DEPARTMENT OF COMMERCE**

**National Oceanic and Atmospheric Administration**

[RTID 0648-XB771]

**Mid-Atlantic Fishery Management Council (MAFMC); Public Meeting**

**AGENCY:** National Marine Fisheries Service (NMFS), National Oceanic and Atmospheric Administration (NOAA), Commerce.

**ACTION:** Notice; public meeting.

**SUMMARY:** The Mid-Atlantic Fishery Management Council's Tilefish Advisory Panel will hold a public webinar meeting. See **SUPPLEMENTARY INFORMATION** for agenda details.

**DATES:** The meeting will be held on Thursday, February 24, 2022, from 9 a.m. until 12 p.m.

**ADDRESSES:** The meeting will be held via webinar. Connection information will be posted to the calendar prior to the meeting at [www.mafmc.org](http://www.mafmc.org).

*Council address:* Mid-Atlantic Fishery Management Council, 800 N State Street, Suite 201, Dover, DE 19901; telephone: (302) 674-2331; [www.mafmc.org](http://www.mafmc.org).

**FOR FURTHER INFORMATION CONTACT:**

Christopher M. Moore, Ph.D., Executive Director, Mid-Atlantic Fishery Management Council, telephone: (302) 526-5255.

**SUPPLEMENTARY INFORMATION:** The purpose of this meeting is for the Advisory Panel to develop a fishery performance report (FPR) for both golden and blueline tilefish. The intent of the FPR is to facilitate a venue for structured input from the Advisory Panel for the tilefish specifications processes. The FPR will be used by the MAFMC's Scientific and Statistical Committee and the Tilefish Monitoring Committee when reviewing golden tilefish specifications and setting blueline tilefish specifications.

**Special Accommodations**

The meeting is physically accessible to people with disabilities. Requests for sign language interpretation or other auxiliary aid should be directed to Shelley Spedden, (302) 526-5251, at least 5 days prior to the meeting date.

*Authority:* 16 U.S.C. 1801 *et seq.*

Dated: January 31, 2022.

**Tracey L. Thompson,**

*Acting Deputy Director, Office of Sustainable Fisheries, National Marine Fisheries Service.*

[FR Doc. 2022-02287 Filed 2-2-22; 8:45 am]

**BILLING CODE 3510-22-P**

**DEPARTMENT OF COMMERCE**

**National Oceanic and Atmospheric Administration**

[RTID 0648-XB759]

**Endangered and Threatened Species; Initiation of a 5-Year Review for North Atlantic Right Whale**

**AGENCY:** National Marine Fisheries Service (NMFS), National Oceanic and

Atmospheric Administration (NOAA), Commerce.

**ACTION:** Notice of initiation of 5-year review; request for information.

**SUMMARY:** NMFS announces its intent to conduct a 5-year review of the North Atlantic right whale (*Eubalaena glacialis*). NMFS is required by the Endangered Species Act to conduct 5-year reviews to ensure that listing classifications of species are accurate. The 5-year review must be based on the best scientific and commercial data available at the time of the review. We request submission of any such information on the North Atlantic right whale, particularly information on its status, threats, and recovery, that has become available since its last 5-year review in 2017.

**DATES:** To allow us adequate time to conduct this review, we must receive your information no later than May 4, 2022. However, we will continue to accept new information about any listed species at any time.

**ADDRESSES:** Submit your information, identified by docket number NOAA-NMFS-2022-0004, by the following method:

- *Federal e-Rulemaking Portal:* Go to [www.regulations.gov](http://www.regulations.gov). In the Search box, enter the above docket number for this notice. Then, click on the Search icon. On the resulting web page, click the "Comment Now!" icon, complete the required fields, and enter or attach your comments.

*Instructions:* NMFS may not consider comments if they are sent by any other method, to any other address or individual, or received after the comment period ends. All comments received are a part of the public record and NMFS will post the comments for public viewing on [www.regulations.gov](http://www.regulations.gov) without change. All personal identifying information (e.g., name, address, etc.), confidential business information, or otherwise sensitive information submitted voluntarily by the sender is publicly accessible. NMFS will accept anonymous comments (enter "N/A" in the required fields if you wish to remain anonymous).

**FOR FURTHER INFORMATION CONTACT:** Diane Borggaard, Greater Atlantic Region Right Whale Recovery Coordinator, 978-282-8453, [diane.borggaard@noaa.gov](mailto:diane.borggaard@noaa.gov).

**SUPPLEMENTARY INFORMATION:** Section 4(c)(2)(A) of the Endangered Species Act (ESA) requires that we conduct a review of listed species at least once every 5 years. The regulations in 50 CFR 424.21 require that we publish a notice in the **Federal Register** announcing species

currently under active review. On the basis of such reviews, under section 4(c)(2)(B) we determine whether a listed species should be delisted, or reclassified from endangered to threatened or from threatened to endangered (16 U.S.C. 1533(c)(2)(B)). As described by the regulations in 50 CFR 424.11(e), the Secretary shall delist a species if the Secretary finds that, after conducting a status review based on the best scientific and commercial data available: (1) The species is extinct; (2) the species does not meet the definition of an endangered species or a threatened species; or (3) the listed entity does not meet the statutory definition of a species. Any change in Federal classification would require a separate rulemaking process.

The North Atlantic right whale has been listed as endangered under the ESA since it was enacted in 1973 (35 FR 18319, December 2, 1970; 73 FR 12024, March 6, 2008). The last North Atlantic right whale 5-year review is available on the NMFS website at: [fisheries.noaa.gov/resource/document/5-year-review-north-atlantic-right-whale-eubalaena-glacialis](http://fisheries.noaa.gov/resource/document/5-year-review-north-atlantic-right-whale-eubalaena-glacialis). Additional background information on the North Atlantic right whale is also available on the website at: [fisheries.noaa.gov/species/north-atlantic-right-whale](http://fisheries.noaa.gov/species/north-atlantic-right-whale).

#### **Determining if a Species Is Threatened or Endangered**

Section 4(a)(1) of the ESA requires that we determine whether a species is endangered or threatened based on one or more of the five following factors: (1) The present or threatened destruction, modification, or curtailment of its habitat or range; (2) overutilization for commercial, recreational, scientific, or educational purposes; (3) disease or predation; (4) the inadequacy of existing regulatory mechanisms; or (5) other natural or manmade factors affecting its continued existence. Section 4(b) also requires that our determination be made on the basis of the best scientific and commercial data available after conducting a review of the status of the species and after taking into account those efforts, if any, being made by any State or foreign nation to protect such species.

#### **Public Solicitation of New Relevant Information**

To ensure that the 5-year review is complete and based on the best scientific and commercial data available, we are soliciting new information from the public, governmental agencies, Tribes, the scientific community, industry, environmental entities, and any other

interested parties concerning the status of the listed North Atlantic right whale. Categories of requested information include: (1) Species biology including, but not limited to, population trends, distribution, abundance, demographics, and genetics; (2) habitat conditions including, but not limited to, amount, distribution, and important features for conservation; (3) status and trends of threats to the species and its habitats; (4) conservation measures that have been implemented that benefit the species, including monitoring data demonstrating effectiveness of such measures; (5) need for additional conservation measures; and (6) other new information, data, or corrections including, but not limited to, taxonomic or nomenclatural changes and improved analytical methods for evaluating extinction risk.

If you wish to provide information for this review, you may submit your information and materials electronically (see **ADDRESSES** section). We request that all information be accompanied by supporting documentation such as maps, bibliographic references, or reprints of pertinent publications. We also would appreciate the submitter's name, address, and any association, institution, or business that the person represents; however, anonymous submissions will also be accepted.

(Authority: 16 U.S.C. 1531 *et seq.*)

Dated: January 28, 2022.

**Angela Somma,**

Chief, Endangered Species Conservation Division, Office of Protected Resources, National Marine Fisheries Service.

[FR Doc. 2022-02187 Filed 2-2-22; 8:45 am]

**BILLING CODE 3510-22-P**

## **DEPARTMENT OF COMMERCE**

### **National Oceanic and Atmospheric Administration**

[RTID 0648-XB766]

#### **Caribbean Fishery Management Council; Public Meeting**

**AGENCY:** National Marine Fisheries Service (NMFS), National Oceanic and Atmospheric Administration (NOAA), Commerce.

**ACTION:** Notice of a public meeting.

**SUMMARY:** The Caribbean Fishery Management Council's (Council) Outreach and Education Advisory Panel (OEAP) will hold a public virtual meeting to discuss the items contained in the agenda in the **SUPPLEMENTARY INFORMATION**.

**DATES:** The OEAP virtual meeting will be held on February 23, 2022, from 12 p.m. to 4 p.m.

**ADDRESSES:** You may join the OEAP public virtual meeting (via Zoom) from a computer, tablet or smartphone by entering the following address:

Join OEAP Zoom Meeting: <https://us02web.zoom.us/j/84039986774?pwd=SUhDc1hXeFloQWF3ajVtL2ZHRGN3Zz09>.

Meeting ID: 840 3998 6774.

Passcode: 179728.

One tap mobile:

+17879667727,,84039986774#

,,, \*179728# Puerto Rico

+19399450244,,84039986774#

,,, \*179728# Puerto Rico

Dial by your location:

+1 787 966 7727 Puerto Rico

+1 939 945 0244 Puerto Rico

+1 787 945 1488 Puerto Rico

+1 669 900 6833 US (San Jose)

+1 929 205 6099 US (New York)

+1 253 215 8782 US (Tacoma)

+1 301 715 8592 US (Washington DC)

+1 312 626 6799 US (Chicago)

+1 346 248 7799 US (Houston)

Meeting ID: 840 3998 6774.

Passcode: 179728.

**FOR FURTHER INFORMATION CONTACT:**

Diana Martino, telephone: (787) 226-8849, Caribbean Fishery Management Council, 270 Muñoz Rivera Avenue, Suite 401, San Juan, Puerto Rico 00918-1903.

**SUPPLEMENTARY INFORMATION:**

**Tentative Agenda**

February 23, 2022

12 p.m.–1 p.m.

—Call to Order

—Adoption of Agenda

—OEAP Chairperson's Report

—Updates:

- Recipe Book
- Illustrated Booklets on Ecosystem Based Fishery Management (EBFM) and US Caribbean MPAs
- CFMC Meeting US Caribbean Marine Protected Areas (MPAs)
- MREP update
- Update status of O&E products Approved by the CFMC: Bulletin boards with fisheries information for fish markets/restaurants and Signs on MPAs, St. Croix MPAs poster and Fact Sheet.

1 p.m.–1:10 p.m.

—Break

1:10 p.m.–4 p.m.

—CFMC 5-Year Strategic Plan:

—Outreach & Education projects to meet Objectives 20 and 21

—Island-Based Fishery Management Plans

—Liaisons reports:

—Wilson Santiago/Puerto Rico

—Nicole Greaux/St. Thomas, USVI

—Mavel Maldonado/St. Croix, USVI

—CFMC Facebook, Instagram and YouTube Communications with Stakeholders

—Other Business

The order of business may be adjusted as necessary to accommodate the completion of agenda items. The meeting will begin on February 23, 2022, at 12 p.m., and will end on February 23, 2022, at 4 p.m. Other than the start time, interested parties should be aware that discussions may start earlier or later than indicated.

**Special Accommodations**

For any additional information on this public virtual meeting, please contact Diana Martino, Caribbean Fishery Management Council, 270 Muñoz Rivera Avenue, Suite 401, San Juan, Puerto Rico, 00918-1903; telephone: (787) 226-8849.

Authority: 16 U.S.C. 1801 *et seq.*

Dated: January 31, 2022.

**Tracey L. Thompson,**

Acting Deputy Director, Office of Sustainable Fisheries, National Marine Fisheries Service.

[FR Doc. 2022-02284 Filed 2-2-22; 8:45 am]

**BILLING CODE 3510-22-P**

**CONSUMER PRODUCT SAFETY COMMISSION**

[CPSC Docket No. 22-C0001]

**Settlement Agreement With Core Health & Fitness, LLC**

**AGENCY:** Consumer Product Safety Commission.

**ACTION:** Notice.

**SUMMARY:** The Commission publishes in the **Federal Register** any settlement that it provisionally accepts under the Consumer Product Safety Act. Published below is a provisionally accepted Settlement Agreement with Core Health and Fitness, LLC, containing a civil penalty in the amount of six million, five hundred thousand dollars (\$6,500,000), subject to the terms and conditions of the Settlement Agreement. The Commission voted unanimously (4-0) to provisionally accept the proposed Settlement Agreement and Order pertaining to Core Health and Fitness, LLC.

**DATES:** Any interested person may ask the Commission not to accept this agreement or otherwise comment on its contents by filing a written request with the Division of the Secretariat by February 18, 2022.

**ADDRESSES:** Persons wishing to comment on this Settlement Agreement should send written comments to Comment 22-C0001, Division of the Secretariat, Consumer Product Safety Commission, Room 820, 4330 East-West Highway, Bethesda, MD 20814; telephone: (240) 863-8938 (mobile), (301) 504-7479 (office); email: [cpsc-os@cpsc.gov](mailto:cpsc-os@cpsc.gov).

**FOR FURTHER INFORMATION CONTACT:**

Liana G.T. Wolf, Trial Attorney, Division of Enforcement and Litigation, Office of Compliance and Field Operations, Consumer Product Safety Commission, 4330 East-West Highway, Bethesda, Maryland 20814-4408; [lwolf@cpsc.gov](mailto:lwolf@cpsc.gov), 301-504-7733.

**SUPPLEMENTARY INFORMATION:** The text of the Agreement and Order appears below.

Dated: January 31, 2022.

**Alberta E. Mills,**

Secretary.

**United States of America**

**Consumer Product Safety Commission**

*In the Matter of:* CORE HEALTH & FITNESS, LLC.

CPSC Docket No.: 22-C0001

**Settlement Agreement**

1. In accordance with the Consumer Product Safety Act (“CPSA”), 15 U.S.C. 2051–2089, and 16 CFR 1118.20, Core Health & Fitness, LLC (“Core”) and the United States Consumer Product Safety Commission (“Commission”), through its staff, hereby enter into this Settlement Agreement (“Agreement”). The Agreement and the incorporated attached Order resolve staff’s charges set forth below.

*The Parties*

2. The Commission is an independent federal regulatory agency, established pursuant to, and responsible for, the enforcement of the CPSA, 15 U.S.C. 2051–2089. By executing the Agreement, staff is acting on behalf of the Commission, pursuant to 16 CFR 1118.20(b). The Commission issues the Order under the provisions of the CPSA.

3. Core is a privately held company, organized and existing under the laws of the state of Nevada, with its principal place of business in Vancouver, Washington.

*Staff Charges*

4. Between 2001 and 2017, Unisen Inc. and Core manufactured, distributed, and offered for sale approximately 3,600 Cable Cross Over Machines and Dual Adjustable Pulley Machines.

5. Between 2001 and 2010, Unisen Inc. manufactured, distributed, and

offered for sale in the United States the Cable Cross Over Machines and Dual Adjustable Pulley Machines.

6. In November 2010, Core purchased the assets of Unisen Inc. and took over the distribution of the Cable Cross Over Machines and Dual Adjustable Pulley Machines.

7. Between 2010 and 2017, Core manufactured, distributed, and offered for sale in the United States the Cable Cross Over Machines and Dual Adjustable Pulley Machines.

8. The Cable Cross Over Machines and Dual Adjustable Pulley Machines (collectively, the "Subject Products") are "consumer products" that were "distribut[ed] in commerce," as those terms are defined or used in sections 3(a)(5) and (8) of the CPSA, 15 U.S.C. 2052(a)(5), (8). Core is a "manufacturer" and "distributor" of the Subject Products, as such terms are defined in sections 3(a)(7) and (11) of the CPSA, 15 U.S.C. 2052(a)(7), (11).

Violation of CPSA Section 19(a)(4)

9. The Subject Products contain a defect which could create a substantial product hazard and create an unreasonable risk of serious injury or death because the height adjusting carriages on the machines can loosen and fall on the consumer, posing an impact injury hazard.

10. Although the Subject Products were sold between 2001 and 2017, Core was only able to produce incident information Core received after August 2012.

11. Between 2012 and February 2017, Core received reports of 55 incidents involving falling carriages, including 11 incidents that resulted in head lacerations requiring stitches or staples.

12. Despite information that reasonably supported the conclusion that the Subject Products contained a defect that could create a substantial product hazard or created an unreasonable risk of serious injury or death, Core did not immediately report to the Commission.

13. In February 2017, Core filed a Full Report with the Commission under 15 U.S.C. 2064(b) concerning the Subject Products.

14. Core and the Commission jointly announced a Fast Track recall of the Subject Products on July 12, 2017. The press release announcing the recall noted that the height adjusting carriage assembly can loosen and fall on the consumer, posing an impact injury hazard.

Failure to Timely Report

15. Despite having information reasonably supporting the conclusion

that the Subject Products contained a defect or created an unreasonable risk of serious injury or death, Core did not notify the Commission immediately of such defect or risk, as required by sections 15(b)(3) and (4) of the CPSA, 15 U.S.C. 2064(b)(3), (4), in violation of section 19(a)(4) of the CPSA, 15 U.S.C. 2068(a)(4).

16. Because the information in Core's possession about the Subject Products constituted actual and presumed knowledge, Core knowingly violated section 19(a)(4) of the CPSA, 15 U.S.C. 2068(a)(4), as the term "knowingly" is defined in section 20(d) of the CPSA, 15 U.S.C. 2069(d).

17. Pursuant to section 20 of the CPSA, 15 U.S.C. 2069, Core is subject to civil penalties for its knowing violation of section 19(a)(4) of the CPSA, 15 U.S.C. 2068(a)(4).

*Response of Core*

18. This Agreement does not constitute an admission by Core to the staff's charges set forth in paragraphs 4 through 17 above, and Core specifically refutes the staff's findings that the Cable Cross Over Machines and Dual Adjustable Pulley Machines contained a defect that could create a substantial product hazard or created an unreasonable risk of serious injury or death; that Core failed to notify the Commission in a timely manner, in accordance with Section 15(b) of the CPSA, 15 U.S.C. 2064(b); and that there was any "knowing" violation of the CPSA as that term is defined in 15 U.S.C. 2069(d).

19. Core enters into this Agreement to settle this matter without the delay and expense of litigation and agrees to pay the amount referenced below in compromise of the staff's charges.

20. Over the relevant time period, Core took various steps to address safety issues gyms brought to its attention in an effort to support their service and maintain the Subject Products. Due to the role of fitness clubs in monitoring and maintaining the equipment, and communicating any such issues to the manufacturer, consumer reports can be difficult for a manufacturer to obtain and evaluate, may not be received promptly, and may not include complete and accurate information. Core was not aware of a systemic or overarching issue with the Subject Products, but rather was working to address what it viewed as a routine maintenance issue.

21. Core voluntarily notified the Commission in connection with the Subject Products and carried out a voluntary recall in cooperation with the Commission.

22. At all relevant times, Core had a product safety compliance program, including quality control personnel and a product safety testing program.

*Agreement of the Parties*

23. Under the CPSA, the Commission has jurisdiction over the matter involving the Subject Products and over Core.

24. The parties enter into the Agreement for settlement purposes only. The Agreement does not constitute an admission by Core or a determination by the Commission that Core violated the CPSA's reporting requirements.

25. In settlement of staff's charges, and to avoid the cost, distraction, delay, uncertainty, and inconvenience of protracted litigation or other proceedings, Core shall pay a civil penalty in the amount of six million five hundred thousand dollars (\$6,500,000) within thirty (30) calendar days after receiving service of the Commission's final Order accepting the Agreement. All payments to be made under the Agreement shall constitute debts owing to the United States and shall be made by electronic wire transfer to the United States via <http://www.pay.gov>, for allocation to, and credit against, the payment obligations of Core under this Agreement. Failure to make such payment by the date specified in the Commission's final Order shall constitute Default.

26. All unpaid amounts, if any, due and owing under the Agreement, shall constitute a debt due and immediately owing by Core to the United States, and interest shall accrue and be paid by Core at the federal legal rate of interest set forth at 28 U.S.C. 1961(a) and (b) from the date of Default, until all amounts due have been paid in full (hereinafter "Default Payment Amount" and "Default Interest Balance"). Core shall consent to a Consent Judgment in the amount of the Default Payment Amount and Default Interest Balance, and the United States, at its sole option, may collect the entire Default Payment Amount and Default Interest Balance, or exercise any other rights granted by law or in equity, including, but not limited to, referring such matters for private collection, and Core agrees not to contest, and hereby waives and discharges any defenses to, any collection action undertaken by the United States, or its agents or contractors, pursuant to this paragraph. Core shall pay the United States all reasonable costs of collection and enforcement under this paragraph, respectively, including reasonable attorney's fees and expenses.

27. After staff receives this Agreement executed on behalf of Core, staff shall promptly submit the Agreement to the Commission for provisional acceptance. Promptly following provisional acceptance of the Agreement by the Commission, the Agreement shall be placed on the public record and published in the **Federal Register**, in accordance with the procedures set forth in 16 CFR 1118.20(e). If the Commission does not receive any written request not to accept the Agreement within fifteen (15) calendar days, the Agreement shall be deemed finally accepted on the 16th calendar day after the date the Agreement is published in the **Federal Register**, in accordance with 16 CFR 1118.20(f).

28. This Agreement is conditioned upon, and subject to, the Commission's final acceptance, as set forth above, and it is subject to the provisions of 16 CFR 1118.20(h). Upon the later of: (i) The Commission's final acceptance of this Agreement and service of the accepted Agreement upon Core, and (ii) the date of issuance of the final Order, this Agreement shall be in full force and effect, and shall be binding upon the parties.

29. *Effective upon the later of:* (i) The Commission's final acceptance of the Agreement and service of the accepted Agreement upon Core and (ii) the date of issuance of the final Order, for good and valuable consideration, Core hereby expressly and irrevocably waives and agrees not to assert any past, present, or future rights to the following, in connection with the matter described in this Agreement: (i) An administrative or judicial hearing; (ii) judicial review or other challenge or contest of the Commission's actions; (iii) a determination by the Commission of whether Core failed to comply with the CPSA and the underlying regulations; (iv) a statement of findings of fact and conclusions of law; and (v) any claims under the Equal Access to Justice Act.

30. Core shall maintain an improved compliance program designed to ensure compliance with the CPSA with respect to any consumer product imported, manufactured, distributed, or sold by Core, and which shall contain the following elements:

(i) Written standards, policies, and procedures, including those designed to ensure that information that may relate

to or impact CPSA compliance is conveyed effectively to personnel responsible for CPSA compliance, whether or not an injury is referenced;

(ii) a mechanism for confidential employee reporting of compliance-related questions or concerns to either a compliance officer or to another senior manager with authority to act as necessary;

(iii) effective communication of company compliance-related policies and procedures regarding the CPSA to all applicable employees through training programs or otherwise;

(iv) Core's senior management responsibility for, and general board oversight of, CPSA compliance; and (v) retention of all CPSA compliance-related records for at least five (5) years, and availability of such records to CPSC staff upon request.

31. Core shall maintain and enforce a system of internal controls and procedures designed to ensure that, with respect to all consumer products imported, manufactured, distributed, or sold by Core:

(i) Information required to be disclosed by Core to the Commission is recorded, processed, and reported in accordance with applicable law;

(ii) all reporting made to the Commission is timely, truthful, complete, accurate, and in accordance with applicable law; and

(iii) prompt disclosure is made to Core's management of any significant deficiencies or material weaknesses in the design or operation of such internal controls that are reasonably likely to affect adversely, in any material respect, Core's ability to record, process and report to the Commission in accordance with applicable law.

32. Upon request of staff, Core shall provide written documentation of its internal controls and procedures, including, but not limited to, the effective dates of the procedures and improvements thereto. Core shall cooperate fully and truthfully with staff and shall make available all non-privileged information and materials, and personnel deemed necessary by staff to evaluate Core's compliance with the terms of the Agreement.

33. The parties acknowledge and agree that the Commission may publicize the terms of the Agreement and the Order.

34. *Core represents that the Agreement:* (i) Is entered into freely and voluntarily, without any degree of duress or compulsion whatsoever; (ii) has been duly authorized; and (iii) constitutes the valid and binding obligation of Core, enforceable against Core in accordance with its terms. The individuals signing the Agreement on behalf of Core represent and warrant that they are duly authorized by Core to execute the Agreement.

35. The signatories represent that they are authorized to execute this Agreement.

36. The Agreement is governed by the laws of the United States.

37. The Agreement and the Order shall apply to, and be binding upon, Core and each of its successors, transferees, and assigns; and a violation of the Agreement or Order may subject Core, and each of its successors, transferees, and assigns, to appropriate legal action.

38. The Agreement and the Order constitute the complete agreement between the parties on the subject matter contained therein.

39. The Agreement may be used in interpreting the Order. Understandings, agreements, representations, or interpretations apart from those contained in the Agreement and the Order may not be used to vary or contradict their terms. For purposes of construction, the Agreement shall be deemed to have been drafted by both of the parties and shall not, therefore, be construed against any party, for that reason, in any subsequent dispute.

40. The Agreement may not be waived, amended, modified, or otherwise altered, except as in accordance with the provisions of 16 CFR 1118.20(h). The Agreement may be executed in counterparts.

41. If any provision of the Agreement or the Order is held to be illegal, invalid, or unenforceable under present or future laws effective during the terms of the Agreement and the Order, such provision shall be fully severable. The balance of the Agreement and the Order shall remain in full force and effect, unless the Commission and Core agree in writing that severing the provision materially affects the purpose of the Agreement and the Order.

## CORE HEALTH &amp; FITNESS, LLC

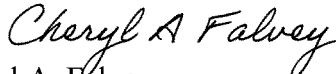
Dated: 1/11/22By:   
Michael Bruno  
Core Health & Fitness, LLC  
Chief Executive OfficerDated: 1/11/22By:   
Cheryl A. Falvey  
Counsel to Core Health & Fitness, LLCU.S. CONSUMER PRODUCT SAFETY  
COMMISSIONMary B. Murphy,  
*Director, Division of Enforcement and  
Litigation, Office of Compliance and Field  
Operations.*

Dated: 1/12/2022

By: Liana G. T. Wolf,  
Digitally signed by Liana G.T. Wolf.

Date: 2022.01.12 17:58:59 -05'00'

Liana G.T. Wolf,  
*Trial Attorney, Division of Enforcement and  
Litigation, Office of Compliance and Field  
Operations.***United States of America, Consumer  
Product Safety Commission***In the Matter of:* CORE HEALTH &  
FITNESS, LLC, CPSC Docket No.: 22-  
C0001**Order**

Upon consideration of the Settlement Agreement entered into between Core Health & Fitness, LLC ("Core"), and the U.S. Consumer Product Safety Commission ("Commission"), and the Commission having jurisdiction over the subject matter and over Core, and it appearing that the Settlement Agreement and the Order are in the public interest, it is:

*Ordered that* the Settlement Agreement be, and is, hereby, accepted; and it is

*Further ordered* that Core shall comply with all terms of the Settlement Agreement including payment of a civil penalty in the amount of six million five hundred thousand dollars (\$6,500,000), within thirty (30) days after service of the Commission's final Order accepting the Settlement Agreement. The payment shall be made by electronic wire transfer to the Commission via: <http://www.pay.gov>. Upon the failure of Core

to make the foregoing payment when due, interest on the unpaid amount shall accrue and be paid by Core at the federal legal rate of interest set forth at 28 U.S.C. 1961(a) and (b). If Core fails to make such payment or to comply in full with any other provision of the Settlement Agreement, such conduct will be considered a violation of the Settlement Agreement and Order.

Provisionally accepted and provisional Order issued on the 25th, day of January 2022.

By Order of the Commission:  
/s/ \_\_\_\_\_  
Alberta Mills,  
*Secretary, U.S. Consumer Product Safety  
Commission.*  
[FR Doc. 2022-02211 Filed 2-2-22; 8:45 am]  
BILLING CODE 6355-01-P

**DEPARTMENT OF EDUCATION****[Docket No.: ED-2022-SCC-0010]****Agency Information Collection  
Activities; Submission to the Office of  
Management and Budget for Review  
and Approval; Comment Request;  
Application Forms and Instructions for  
the Fulbright-Hays Seminars Abroad  
Program****AGENCY:** Office of Postsecondary  
Education (OPE), Department of  
Education (ED).**ACTION:** Notice.**SUMMARY:** In accordance with the  
Paperwork Reduction Act of 1995, ED is  
proposing a revision of a currently  
approved collection.**DATES:** Interested persons are invited to  
submit comments on or before March 7,  
2022.

**ADDRESSES:** Written comments and  
recommendations for proposed  
information collection requests should  
be sent within 30 days of publication of  
this notice to [www.reginfo.gov/public/  
do/PRAMain](http://www.reginfo.gov/public/do/PRAMain). Find this information  
collection request by selecting  
"Department of Education" under  
"Currently Under Review," then check  
"Only Show ICR for Public Comment"  
checkbox. Comments may also be sent  
to [ICDocketmgr@ed.gov](mailto:ICDocketmgr@ed.gov).

**FOR FURTHER INFORMATION CONTACT:** For  
specific questions related to collection  
activities, please contact Matthew  
Robinson, 202-453-6024.

**SUPPLEMENTARY INFORMATION:** The  
Department of Education (ED), in  
accordance with the Paperwork  
Reduction Act of 1995 (PRA) (44 U.S.C.  
3506(c)(2)(A)), provides the general  
public and Federal agencies with an  
opportunity to comment on proposed,  
revised, and continuing collections of  
information. This helps the Department  
assess the impact of its information  
collection requirements and minimize  
the public's reporting burden. It also  
helps the public understand the  
Department's information collection  
requirements and provide the requested  
data in the desired format. ED is  
soliciting comments on the proposed  
information collection request (ICR) that  
is described below. The Department of  
Education is especially interested in  
public comment addressing the  
following issues: (1) Is this collection  
necessary to the proper functions of the  
Department; (2) will this information be  
processed and used in a timely manner;  
(3) is the estimate of burden accurate;  
(4) how might the Department enhance  
the quality, utility, and clarity of the  
information to be collected; and (5) how

might the Department minimize the burden of this collection on the respondents, including through the use of information technology. Please note that written comments received in response to this notice will be considered public records.

*Title of Collection:* Application Forms and Instructions for the Fulbright-Hays Seminars Abroad Program.

*OMB Control Number:* 1840-0501.

*Type of Review:* A revision of a currently approved collection.

*Respondents/Affected Public:* Individuals and Households.

*Total Estimated Number of Annual Responses:* 300.

*Total Estimated Number of Annual Burden Hours:* 900.

*Abstract:* The Department of Education (US/ED) is responsible for administering the Fulbright-Hays Seminars Abroad (SA) Program under authority of Section 102(b)(6) of the Mutual Educational and Cultural Exchange (Fulbright-Hays) Act of 1961, as amended. The program is administered under the policies established by the J. William Fulbright Foreign Scholarship Board (FSB), a 12-member body appointed by the President. US/ED recruits and recommends candidates for seminar positions abroad in accordance with FSB policies, which support the purposes of the Fulbright-Hays Act. The application is necessary in order for the Department to award funds under this program.

This is a revision of a currently approved collection. The suggested changes from the currently approved application are minor, and consist of mainly updated language to reflect improvements in clarity and minor updates to instructions. The burden of the applicants is an average of three hours for each applicant and includes the time needed to obtain references. There is no change in burden per response.

This collection is being submitted under the Streamlined Clearance Process for Discretionary Grant Information Collections (1894-0001). Therefore, the 30-day public comment period notice will be the only public comment notice published for this information collection request.

Dated: January 31, 2022.

**Kate Mullan,**

*PRA Coordinator, Strategic Collections and Clearance Governance and Strategy Division, Office of Chief Data Officer Office of Planning, Evaluation and Policy Development.*

[FR Doc. 2022-02189 Filed 2-2-22; 8:45 am]

**BILLING CODE 4000-01-P**

## DEPARTMENT OF EDUCATION

### Application Deadline for Fiscal Year 2022; Small, Rural School Achievement Program

**AGENCY:** Office of Elementary and Secondary Education, Department of Education.

**ACTION:** Notice.

**SUMMARY:** Under the Small, Rural School Achievement (SRSA) program, Assistance Listing Number 84.358A, the U.S. Department of Education (Department) awards grants on a formula basis to eligible local educational agencies (LEAs) to address the unique needs of rural school districts. In this notice, we establish the deadline and describe the submission procedures for fiscal year (FY) 2022 SRSA grant applications. This notice relates to the approved information collection under OMB control number 1810-0646. All LEAs eligible for FY 2022 SRSA funds must submit an application electronically via the process described in this notice by the deadline in this notice.

#### **DATES:**

*Applications Available:* February 9, 2022.

*Deadline for Transmittal of Applications:* April 15, 2022.

**FOR FURTHER INFORMATION CONTACT:** Ms. Leslie Poynter, U.S. Department of Education, 400 Maryland Avenue SW, Washington, DC 20202. Telephone: (202) 401-0039. Email: [reap@ed.gov](mailto:reap@ed.gov).

If you use a telecommunications device for the deaf (TDD) or a text telephone (TTY), call the Federal Relay Service, toll free, at 1-800-877-8339.

#### **SUPPLEMENTARY INFORMATION:**

##### **I. Award Information**

*Type of Award:* Formula grant.

*Available Funds:* The Administration has requested \$96,420,000 for SRSA in FY 2022. The actual level of funding, if any, depends on final congressional action. However, we are inviting applications to allow enough time to complete the grant process if Congress appropriates funds for this program.

*Estimated Range of Awards:* \$0-\$60,000.

*Note:* Depending on the number of eligible LEAs identified in a given year and the amount appropriated by Congress for the program, some eligible LEAs may receive an SRSA allocation of \$0 under the statutory funding formula.

*Estimated Number of Awards:* 4,260.

## II. Program Authority and Eligibility Information

*Under what statutory authority will FY 2022 SRSA grant awards be made?*

The FY 2022 SRSA grant awards will be made under title V, part B, subpart 1 of the Elementary and Secondary Education Act of 1965, as amended (ESEA).

*Which LEAs are eligible for an award under the SRSA program?*

For FY 2022, a LEA (including a public charter school that meets the definition of LEA in section 8101(30) of the ESEA) is eligible for an award under the SRSA program if it meets both criteria below:

(a) The total number of students in average daily attendance at all of the schools served by the LEA is fewer than 600; or each county in which a school served by the LEA is located has a total population density of fewer than 10 persons per square mile; and

(b) All of the schools served by the LEA are designated with a school locale code of 41, 42, or 43 by the Department's National Center for Education Statistics (NCES); or the Secretary has determined, based on a demonstration by the LEA and concurrence of the State educational agency, that the LEA is located in an area defined as rural by a governmental agency of the State.

The Department provides an eligibility spreadsheet containing each LEA eligible for FY 2022 SRSA grant funds, which is available on the Department's website at: <https://oese.ed.gov/offices/office-of-formula-grants/rural-insular-native-achievement-programs/rural-education-achievement-program/small-rural-school-achievement-program/eligibility/>.

If an LEA on the Department's list of LEAs eligible to receive an FY 2022 SRSA award will close prior to the 2022-2023 school year, that LEA is no longer eligible to receive an FY 2022 SRSA award and should not apply.

*Note:* The "Choice of Participation" provision under section 5225 of the ESEA gives an LEA eligible for both SRSA and the Rural and Low-Income School (RLIS) program authorized under title V, part B, subpart 2 of the ESEA the option to participate in either the SRSA program or the RLIS program. An LEA eligible for both SRSA and RLIS is henceforth referred to as a "dual-eligible LEA."

Which eligible LEAs must submit an application to receive an FY 2022 SRSA grant award?

Under 34 CFR 75.104(a), the Secretary makes a grant only to an eligible entity that submits an application.

In FY 2022, each LEA eligible to receive an SRSA award is required to submit an SRSA application in order to receive SRSA funds, regardless of whether the LEA received an award or submitted an application in any previous year. This includes each dual-eligible LEA that chooses to participate in the SRSA program instead of the RLIS program, and each SRSA-eligible LEA that is a member of an educational service agency (ESA) that does not receive SRSA funds on the LEA's behalf. In the case of an SRSA-eligible LEA that is a member of an SRSA-eligible ESA, the LEA and ESA must coordinate with each other to determine which entity will submit an SRSA application on the LEA's behalf, as both entities may not apply for or receive SRSA funds for the LEA. Pursuant to section 5225 of the ESEA, a dual-eligible LEA that applies for SRSA funds in accordance with these application submission procedures will not be considered for an RLIS award.

A separate application must be submitted for each eligible LEA and each applicant must apply with its own unique entity identifier pursuant to 2 CFR part 25. For example, if a rural community has two distinct LEAs—one composed of its elementary school(s) and one composed of its high school(s)—each LEA is required to submit its own SRSA application with the LEA's own unique entity identifier.

An LEA eligible to receive FY 2022 SRSA funds that fails to submit an FY 2022 SRSA application in accordance with the requirements below risks not receiving an FY 2022 SRSA award. The Department may consider applications submitted after the deadline to the extent practicable and contingent upon the availability of funding.

As noted above, each applicant must apply with its own unique entity identifier. The applicant's Data Universal Numbering System (DUNS) number will serve as the entity identifier until April 4, 2022, when the Federal Government transitions government-wide from using DUNS numbers to the new Unique Entity Identifier (UEI) system for Federal awards. For more information and resources on the transition from DUNS number to UEI, please visit the Federal Service Desk website at [fsd.gov](https://fsd.gov).

### III. Application and Submission Information

#### Electronic Submission of Applications Using MAX.gov

The Department will email each LEA eligible for FY 2022 SRSA grant funds a uniquely identifiable application link on February 9, 2022. The email will include customized instructions for completing the electronic application via the *Office of Management and Budget (OMB) MAX Survey* platform.

An eligible LEA must submit an electronic application via *OMB MAX Survey* by April 15, 2022, to be assured of receiving an FY 2022 SRSA grant award. The Department may consider applications submitted after the deadline to the extent practicable and contingent upon the availability of funding.

Please note the following:

- We estimate that it will take 30 minutes to submit an application. We strongly recommend that you do not wait until the application deadline date to begin the application process, however.
- To better ensure applications are processed in a timely, accurate, and efficient manner, we will send reminder emails to any LEAs that have not submitted applications by March 1, 2022.

- An application received by *OMB MAX Survey* is date and time stamped upon submission and an applicant will receive a confirmation email after the application is submitted.

- If you need to update any information in the application after it has been submitted via *OMB MAX Survey*, you must contact the REAP program staff directly at [reap@ed.gov](mailto:reap@ed.gov).

#### Application Deadline Date Extension in Case of Technical Issues With OMB MAX Survey

If you are unable to submit an application by April 15, 2022, because of technical problems with *OMB MAX Survey*, contact the REAP program staff at [reap@ed.gov](mailto:reap@ed.gov) within five business days and explain the technical problem you experienced. We will accept your late application as having met the deadline if we can confirm that a technical problem occurred with the *OMB MAX Survey* system and that the problem affected your ability to submit your application by the application deadline date. As noted above, if you submit your application after the deadline and the late submission is not due to a technical issue about which you have notified the REAP program staff, the Department may consider your application to the extent practicable and

contingent upon the availability of funding.

### IV. Other Procedural Requirements

#### System for Award Management

To do business with the Department, you must register in the System for Award Management (SAM), the Federal Government's primary registrant database, using the following information:

- a. DUNS number until April 3, 2022, and UEI starting April 4, 2022.
- b. Legal business name.
- c. Physical address associated with your DUNS number or UEI.
- d. Taxpayer identification number (TIN).
- e. Taxpayer name associated with your TIN.
- f. Bank information to set up Electronic Funds Transfer (EFT) (*i.e.*, routing number, account number, and account type (checking/savings)).

For assistance on the SAM registration process, including directions for how to check your entity's registration status, please view the resources or utilize the live chat function on the *FSD.gov* website.

### V. Accessibility Information and Program Authority

**Accessible Format:** On request to the program contact person listed under **FOR FURTHER INFORMATION CONTACT**, individuals with disabilities can obtain this document and a copy of the application package in an accessible format. The Department will provide the requestor with an accessible format that may include Rich Text Format (RTF) or text format (txt), a thumb drive, an MP3 file, braille, large print, audiotape, or compact disc, or other accessible format.

**Electronic Access to This Document:** The official version of this document is the document published in the **Federal Register**. You may access the official edition of the **Federal Register** and the Code of Federal Regulations at [www.govinfo.gov](https://www.govinfo.gov). At this site you can view this document, as well as all other documents of this Department published in the **Federal Register**, in text or Portable Document Format (PDF). To use PDF you must have Adobe Acrobat Reader, which is available free at the site.

You may also access documents of the Department published in the **Federal Register** by using the article search feature at [www.federalregister.gov](https://www.federalregister.gov). Specifically, through the advanced search feature at this site, you can limit your search to documents published by the Department.



*Program Authority:* Sections 5211–5212 of the ESEA, 20 U.S.C. 7345–7345a.

**Ian Rosenblum,**

*Deputy Assistant Secretary for Policy and Programs, Delegated the Authority to Perform the Functions and Duties of the Assistant Secretary.*

[FR Doc. 2022–02179 Filed 2–2–22; 8:45 am]

**BILLING CODE 4000–01–P**

## DEPARTMENT OF EDUCATION

[Docket No. ED–2022–SCC–0011]

### Agency Information Collection Activities; Comment Request; Supplemental Support Under the American Rescue Plan (SSARP) Application

**AGENCY:** Office of Postsecondary Education (OPE), Department of Education (ED).

**ACTION:** Notice.

**SUMMARY:** In accordance with the Paperwork Reduction Act of 1995, ED is requesting the Office of Management and Budget (OMB) to conduct an emergency review of a new information collection.

**DATES:** The Department requested emergency processing from OMB for this information collection request on January 31, 2022. As a result, the Department is providing the public with the opportunity to comment under the full comment period. Interested persons are invited to submit comments on or before April 4, 2022.

**ADDRESSES:** To access and review all the documents related to the information collection listed in this notice, please use <http://www.regulations.gov> by searching the Docket ID number ED–2022–SCC–0011. Comments submitted in response to this notice should be submitted electronically through the Federal eRulemaking Portal at <http://www.regulations.gov> by selecting the Docket ID number or via postal mail, commercial delivery, or hand delivery. If the regulations.gov site is not available to the public for any reason, ED will temporarily accept comments at [ICDocketMgr@ed.gov](mailto:ICDocketMgr@ed.gov). Please include the docket ID number and the title of the information collection request when requesting documents or submitting comments. *Please note that comments submitted by fax or email and those submitted after the comment period will not be accepted.* Written requests for information or comments submitted by postal mail or delivery should be addressed to the Director of the Strategic Collections and Clearance Governance

and Strategy Division, U.S. Department of Education, 400 Maryland Ave. SW, LBJ, Room 6W208D, Washington, DC 20202–4537.

**FOR FURTHER INFORMATION CONTACT:** For specific questions related to collection activities, please contact Karen Epps, 202–453–6337.

**SUPPLEMENTARY INFORMATION:** The Department of Education (ED), in accordance with the Paperwork Reduction Act of 1995 (PRA) (44 U.S.C. 3506(c)(2)(A)), provides the general public and Federal agencies with an opportunity to comment on proposed, revised, and continuing collections of information. This helps the Department assess the impact of its information collection requirements and minimize the public's reporting burden. It also helps the public understand the Department's information collection requirements and provide the requested data in the desired format. ED is soliciting comments on the proposed information collection request (ICR) that is described below. The Department of Education is especially interested in public comment addressing the following issues: (1) Is this collection necessary to the proper functions of the Department; (2) will this information be processed and used in a timely manner; (3) is the estimate of burden accurate; (4) how might the Department enhance the quality, utility, and clarity of the information to be collected; and (5) how might the Department minimize the burden of this collection on the respondents, including through the use of information technology. Please note that written comments received in response to this notice will be considered public records.

*Title of Collection:* Supplemental Support under the American Rescue Plan (SSARP) Application.

*OMB Control Number:* 1840–0860.

*Type of Review:* A new information collection.

*Respondents/Affected Public:* Private Sector; State, Local, and Tribal Governments.

*Total Estimated Number of Annual Responses:* 300.

*Total Estimated Number of Annual Burden Hours:* 900.

*Abstract:* Section 2003 of the American Rescue Plan allocates funds for institutions of higher education that the Secretary determines have the greatest unmet needs related to the coronavirus. This collection includes (1) a certification and agreement and (2) a profile form that will be used by institutions applying for discretionary grant funding under this section.

Dated: January 31, 2022.

**Kate Mullan,**

*PRA Coordinator, Strategic Collections and Clearance, Governance and Strategy Division, Office of Chief Data Officer, Office of Planning, Evaluation and Policy Development.*

[FR Doc. 2022–02262 Filed 2–2–22; 8:45 am]

**BILLING CODE 4000–01–P**

## DEPARTMENT OF EDUCATION

### Applications for New Awards; Supplemental Support Under the American Rescue Plan

**AGENCY:** Office of Postsecondary Education, Department of Education.

**ACTION:** Notice.

**SUMMARY:** The Department of Education (Department) is issuing a notice announcing the availability of funds and the application deadline for new grants to institutions of higher education under the Higher Education Emergency Relief Fund (HEERF or HEERF III), Supplemental Support under the American Rescue Plan (SSARP) program, Assistance Listing Number (ALN) 84.425T. The SSARP program supports institutions of higher education (IHEs or institutions) with the greatest unmet needs related to the novel coronavirus 2019 pandemic (coronavirus or COVID–19).

**DATES:**

*Applications available:* February 3, 2022.

*Deadline for transmittal of applications:* April 4, 2022.

**ADDRESSES:** For the addresses for obtaining and submitting an application, please refer to our Common Instructions for Applicants to Department of Education Discretionary Grant Programs, published in the **Federal Register** on December 27, 2021 (86 FR 73264) and available at [www.federalregister.gov/d/2021-27979](http://www.federalregister.gov/d/2021-27979). Please note that these Common Instructions supersede the version published on February 13, 2019, and, in part, describe the transition from the requirement to register in SAM.gov a Data Universal Numbering System (DUNS) number to the implementation of the Unique Entity Identifier (UEI). More information on the phase-out of DUNS number is available at [www2.ed.gov/about/offices/list/fofo/docs/unique-entity-identifier-transition-fact-sheet.pdf](http://www2.ed.gov/about/offices/list/fofo/docs/unique-entity-identifier-transition-fact-sheet.pdf).

**FOR FURTHER INFORMATION CONTACT:** Karen Epps, U.S. Department of Education, 400 Maryland Avenue SW, Room 2B133, Washington, DC 20202–

6450. Telephone: (202) 377-3711.

Email: [HEERF@ed.gov](mailto:HEERF@ed.gov).

If you use a telecommunications device for the deaf (TDD) or a text telephone (TTY), call the Federal Relay Service (FRS), toll free, at 1-800-877-8339.

#### SUPPLEMENTARY INFORMATION:

#### Full Text of Announcement

#### I. Funding Opportunity Description

*Purpose of Program:* The SSARP program supports public and private nonprofit IHEs that the Secretary determines have, after allocating other funds available under HEERF III, the greatest unmet needs related to the coronavirus, including institutions with large populations of graduate students and institutions that did not otherwise receive a HEERF allocation under the American Rescue Plan Act, 2021 (ARP).

*Background:* On March 11, 2021, the ARP (Pub. L. 117-2) was signed into law. ARP section 2003, as incorporating the Coronavirus Response and Relief Supplemental Appropriations Act, 2021 (CRRSAA) section 314(a)(3), requires the Secretary of Education to allocate 0.5 percent of HEERF III funding (\$198 million) for discretionary grants under part B of title VII of the Higher Education Act of 1965, as amended (HEA), for public and private nonprofit IHEs that the Secretary determines have, after allocating other funds available under HEERF III, the greatest unmet needs related to coronavirus, including institutions with large populations of graduate students and institutions that did not otherwise receive an allocation under ARP. Proprietary institutions are not eligible for funding since eligibility is limited to those institutions that are eligible under part B of title VII of the HEA.

HEERF has been a critical lifeline to aid institutions in meeting urgent public health needs to prevent and respond to the Coronavirus pandemic, providing Emergency Financial Aid Grants to Students to support continued enrollment and learning, addressing student basic needs, providing mental health and other immediate support.

As institutions continue to address the immediate challenges brought on by the pandemic, the Department encourages institutions applying for the SSARP program to use the funding to support campuses and students in the following ways:

(1.) *Covid-19 mitigation:* ARP requires that institutions spend a portion of their HEERF grant funds to implement evidence-based practices to monitor and suppress coronavirus in accordance with public health guidelines.

According to a recent survey of college presidents conducted by the American Council on Education, nearly 90 percent of institutions used HEERF to purchase COVID-19 tests, conduct health screening, and meet other urgent health needs.<sup>1</sup> The Department has heard from institutions of the importance of HEERF in implementing testing and contact tracing, purchasing PPE, HVAC, and other ventilation system improvements to prevent the spread of COVID-19, and in providing vaccine clinics and incentives, and the Department continues to encourage institutions to use HEERF grant funds in these ways.

(2.) *Addressing students' basic needs:* HEERF provides broad flexibility to each institution to address specific student needs related to coronavirus. Many institutions have used HEERF to expand student support services for underserved students by covering the cost of childcare, expanding access to campus-based food pantries and meal programs, subsidizing on- and off-campus housing, providing transportation subsidies, and expanding campus health services and other mental health supports.

(3.) *Support continued enrollment and re-enrollment:* Community colleges and other institutions are facing significant enrollment declines, and as of January 2022 enrollment overall is estimated to have fallen by over 900,000 students since the beginning of the pandemic.<sup>2</sup> HEERF grant funds should be used to support continued enrollment and re-enrollment by providing additional emergency grant aid to students, subsidizing the cost of college to students, and providing additional student supports.

(4.) *Forgive institutional debts and end transcript withholding:* Small sums of money owed on student account balances can derail enrollment, limit transfer, and restrict access to jobs and earning potential. Many institutions, including Historically Black Colleges and Universities (HBCUs), Tribal Colleges and Universities (TCUs), Minority-Serving Institutions (MSIs), and community colleges, have forgiven unpaid balances for students enrolled during the time of the coronavirus pandemic and taken steps to end transcript withholding, allowing students to move forward with subsequent opportunities.

(5.) *Expanding programs that lead to in-demand high-quality jobs:* HEERF has

aided institutions in creating access to new programs that prepare students for high-quality jobs in demand, as a result of the coronavirus, that require specialized training and education.

*Development of Institutional Eligibility Criteria for the SSARP program:* To determine the types of institutions that would be funded under the statutory focus on "greatest unmet needs related to coronavirus," the Department published a notice on May 11, 2021 on its ARP HEERF III website ([www2.ed.gov/about/offices/list/ope/arpheerfiii3proposednotice.pdf](http://www2.ed.gov/about/offices/list/ope/arpheerfiii3proposednotice.pdf)) that announced the Department's proposed institutional eligibility criteria for the SSARP program and invited public comment.

The Department accepted public comments from May 11 to May 25, 2021. The Department received comments from three entities representing institutions of higher education and trade associations supporting the Department's absolute priorities, inclusion of MSIs, and majority graduate institutions. Commenters suggested the Department broaden its proposed priorities in several ways. One commenter urged the Department to consider making awards to institutions that more recently gained eligibility as MSIs. Another commenter requested that we expand the use of funds beyond Emergency Financial Aid Grants to Students. Finally, one commenter requested that the Department include as eligible applicants IHEs with non-traditional academic programming that may have been underfunded under previous iterations of HEERF.

Although we appreciate the commenters' feedback on the proposed categories of eligible applicants, we believe the Department's proposed categories better reflect the intent of ARP section 2003 and the CRRSAA section 314(a)(3) to prioritize both institutions that would have otherwise received a HEERF allocation and providing Emergency Financial Aid Grants to Students. Accordingly, in this notice, we provide for five absolute priorities that represent separate funding categories for different categories of eligible applicants. In developing these absolute priorities, we have broadened the proposed categories of eligible applicants to better account for ways in which institutions may have been underfunded or have unmet needs related to coronavirus. In addition, in this notice, we establish the requirements an institution must meet to establish its eligibility under each of the five absolute priorities.

<sup>1</sup> <https://www.acenet.edu/Research-Insights/Pages/Senior-Leaders/Presidents-Survey-HEERF.aspx>.

<sup>2</sup> <https://nscresearchcenter.org/current-term-enrollment-estimates/>.

**Priorities:** This notice contains five absolute priorities. We are establishing these priorities for fiscal year (FY) 2022 grant competitions and any subsequent year in which we make awards from the list of unfunded applications from this competition, in accordance with section 437(d)(1) of the General Education Provisions Act (GEPA), 20 U.S.C. 1232(d)(1).

**Absolute Priorities:** These priorities are absolute priorities. Under 34 CFR 75.105(c)(3), we consider only applications that meet one or more of these priorities.

The Secretary intends to award grants under each of the absolute priorities. Applicants must clearly identify the absolute priority or priorities that the proposed project addresses in the SSARP Program Profile Information Form (Profile Form). Each applicant must submit only one application, but an applicant may apply to receive funds under multiple priorities.

In selecting grantees under the absolute priorities, the Department will fund each applicant according to the absolute priority or priorities under which it is applying. We will allocate funds under the allocation formula specific to the applicable priority or priorities. Should funding requests in approved applications exceed available funding under the ARP (a)(3) program, the Department reserves the right to make ratable reductions for any of the allocations under Absolute Priorities 1–3 and to determine the amount of funding needed to support each of the absolute priorities based on applications received. For Absolute Priorities 4 and 5, the Department may also prioritize awards to applicants that did not receive funding under priorities 6 and 7 in the Supplemental Assistance to Institutions of Higher Education (SAIHE) program,<sup>3</sup> depending on the number of applications received.

These priorities are:

**Absolute Priority 1: Underfunded (a)(1) Grantees due to Technical Errors, Application Issues, or not Reporting in IPEDS:**

**Background:** Under Absolute Priority 1, the Department will provide funding to institutions that did not receive CRRSAA (a)(1) funding because the applicant did not apply by the deadline or did not submit a complete application under the correct *grants.gov* funding opportunity number.

The Department will also fund institutions that could have been

eligible to receive funding under ARP (a)(1) but did not receive an allocation because they did not report 2018/19 student data in the Integrated Postsecondary Education Data System (IPEDS), which were the data used in calculating the formula awards for ARP (a)(1).

**Note:** Institutions that were included on the ARP (a)(1) allocation table *should not* apply here. To accommodate institutions that missed the ARP (a)(1) application deadline, the Department is reopening the ARP (a)(1) application in a separate notice.

**Absolute Priority 1:** The Department invites applications from institutions that were underfunded under CRRSAA or ARP (a)(1) for any of the following reasons:

(a) The institution was identified within the Department's allocation table<sup>4</sup> as eligible to receive funding under the Coronavirus Response and Relief Supplemental Appropriations Act, 2021 (CRRSAA) (a)(1) but did not receive an award because the applicant did not apply by the deadline or did not submit a complete application under the correct *grants.gov* funding opportunity number.

(b) The institution could have been eligible to receive funding under ARP (a)(1) but did not receive an allocation because it did not report 2018/19 student data in the IPEDS, which are the data used in calculating the formula awards for ARP (a)(1).

**Award Amounts:** Under paragraph (a) of Absolute Priority 1(a), the funds will be allocated based on the allocations institutions were eligible to receive under CRRSAA, (a)(1). For Absolute Priority 1(b), allocations will be based on the formula methodology that was used for ARP (a)(1), except that the Department will use updated (2019–2020) IPEDS and FSA Pell Volume data. If institutions believe these data do not capture their need (*e.g.*, they did not report to IPEDS their 2019–2020 enrollment), they may provide alternative data in the Profile Form.

**Student Grant Minimum:** A grantee under paragraph (a) of this priority must use its award to fund Emergency Financial Aid Grants to Students in the amount that would have been required had they received a CRRSAA (a)(1) award. A grantee under paragraph (b) of this priority must use its award to fund Emergency Financial Aid Grants to Students in the amount that would have been required had they received an ARP (a)(1) award.

**Absolute Priority 2: MSI or Strengthening Institutions Program (SIP) Grantees that were Underfunded due to Technical Errors or Application Issues,**

*are Newly Eligible, or are a Branch Campus:*

**Background:** Under Absolute Priority 2, the Department invites institutions to apply that should have received funds but did not, or were underfunded, under MSI or SIP funding streams for several reasons.

Specifically, the Department intends to fund applicants that did not receive ARP(a)(2) funding but have gained new or additional eligibility for funds since the time the Department initially allocated ARP (a)(2) funding on May 11, 2021 through December 31, 2021, including through FY 21 grant competitions, or were a branch campus designated as eligible under titles III and V of the HEA according to the FY 2021 Eligibility Matrix but were not funded under ARP (a)(2) either directly or through their parent institutions because the Department did not have the requisite data to calculate their allocations. The Department also plans to fund institutions that did not receive an award under CRRSAA (a)(2) because the applicant did not successfully apply by the deadline or failed to submit a complete application under the correct funding opportunity number.

**Note:** Institutions that were included on the ARP (a)(2) allocation table but did not receive an award *should not* apply here. To accommodate these institutions, the Department plans to reopen the ARP (a)(2) application in a separate notice.

**Absolute Priority 2:** The Department invites applications from IHEs that should have received funds but did not, or were underfunded, under the HEERF (a)(2) MSI/SIP funding streams for any of the following reasons:

(a) The institution has gained new or additional eligibility for funds since the time the Department initially allocated ARP (a)(2) funding because the institution was:

(1) Previously designated as ineligible for ARP (a)(2) funds but has since been designated as eligible under titles III or V of the HEA through December 31, 2021; or

(2) Previously eligible under the MSI or SIP funding stream but is now eligible under one or more additional (a)(2)-MSI categories.

(b) The institution did not receive an award under CRRSAA (a)(2) because the institution did not successfully apply by the deadline, or because the institution failed to submit a complete application under the correct funding opportunity number.

(c) The institution was a branch campus designated as eligible under titles III and V of the HEA (according to the FY 2021 Eligibility Matrix) but was

<sup>3</sup> The SAIHE program under CRRSAA HEERF (HEERF II) addressed institutions' unmet needs due to coronavirus. The Department announced awards under that program on July 29, 2021.

not funded under ARP(a)(2) either directly or through its parent institution because the Department did not have the requisite data to calculate its allocation.

**Award Amounts:** For Absolute Priority 2(a) and (c), the funds will be allocated based on the formula methodology in CRRSAA section 314(a)(2) that was used to calculate ARP (a)(2) MSI/SIP allocations. For institutions that were allocated funds under ARP(a)(2) SIP but that have been designated eligible as an MSI, the Department will calculate the award the institution would have received as an MSI and subtract the award the institution already received under SIP. For Absolute Priority 2(b), amounts will be based on the amounts allocated on the CRRSAA (a)(2) allocation tables.

**Absolute Priority 3: Underfunded ARP (a)(1) Grantees due to an Institutional Merger or Change in Program Participation Agreement (PPA):**

**Background:** Under Absolute Priority 3, the Department invites applications from institutions that can demonstrate their ARP (a)(1) allocation was underfunded or not funded because their student enrollment or Pell recipient total was undercounted due to an institutional merger not captured in their ARP (a)(1) allocation, or a recent change in their HEA Title IV PPA effective date resulting in the institution being underfunded due to the formula methodology used to calculate allocations under ARP(a)(1). An institution might be eligible under this Absolute Priority if it currently has a certified and approved PPA but did not have one during the 2018–19 award year.

**Absolute Priority 3:** The Department invites applications from institutions that can demonstrate their ARP (a)(1) allocation was underfunded or not funded because their student enrollment or Pell recipient total was undercounted due to—

(a) An institutional merger not captured in their ARP (a)(1) allocation; or

(b) A change in their HEA Title IV PPA effective date through December 31, 2021, resulting in the institution being underfunded due to the formula methodology used to calculate allocations under ARP (a)(1) award amounts.

**Award Amounts:** The funds will be allocated based on the ARP (a)(1) formula methodology, using updated (2019–2020) IPEDS and FSA Pell Volume data. Institutions that believe these data do not capture their need (e.g., they did not report 2019–2020 enrollment to IPEDS) may provide

alternative data in the Profile Form. The Department will deduct any funds already received under ARP (a)(1) by the institutions in making awards.

**Student Grant Minimum:** A grantee under this priority must use its award to fund Emergency Financial Aid Grants to Students in the amount that would have been required had they received an ARP (a)(1) award.

**Absolute Priority 4: Community Colleges and Rural IHEs Serving a High Percentage of Low-Income Students and Experiencing Enrollment Declines:**

**Background:** The pandemic has disproportionately impacted low-income students and the community colleges that help serve those students. According to data from the U.S. Census Bureau Household Pulse Survey, the lowest-income households with at least one expected student enrolling in postsecondary education were three times more likely to cancel their enrollment plans entirely compared to the highest income households.<sup>5</sup>

In response to these enrollment declines, under Absolute Priority 4, the Department invites applications from community colleges that serve a high percentage of low-income students and have experienced significant enrollment declines, and from IHEs located in rural settings that serve a high percentage of low-income students and have experienced significant enrollment declines.

Under this priority, the Department has set a minimum threshold for these institutions, both of which must be met to receive funds: (1) 50 percent or more of degree/certificate-seeking undergraduate students enrolled in Fall 2019 were Pell Grant recipients; and (2) a 4.5 percent or greater decline in student enrollment from Fall 2019 to Fall 2020. These percentages were set using data from IPEDS and represent the Department's attempt to prioritize institutions that have the greatest unmet needs.

Through this priority, the Department seeks to make awards to the identified categories of IHEs for the purposes of (1) providing additional financial aid to students to support their continued enrollment and re-enrollment in postsecondary education and (2) providing institutional funding that allows institutions to continue to support, engage, and reengage their students. Depending on the number of applications received, the Department may prioritize institutions that did not receive funds under the SAIHE program for the same priority.

**Absolute Priority 4:** The Department invites applications from community colleges, and IHEs located in rural settings, that—

(a) Had 50 percent or more of degree/certificate-seeking undergraduate students enrolled in Fall 2019 who were Pell Grant recipients; and

(b) Experienced a 4.5 percent or greater decline in student enrollment from Fall 2019 to Fall 2020.

**Award amounts:** Awards under this absolute priority will be based on each institution's relative share of Pell Grant recipients using FSA Pell Program volume data in 2019–2020. The per-Pell-recipient amount will be established after the Department receives all the applications under this priority.

**Student Grant Minimum:** A grantee under this priority must use at least 50 percent of its award for Emergency Financial Aid Grants to Students.

**Note:** The following campus settings will be considered rural: Town-Fringe, Town-Distant, Town-Remote, Rural Fringe, Rural-Distant, and Rural-Remote, as defined by the National Center for Education Statistics (NCES) College Navigator search tool.

Applicants may look up individual campus locale settings at: <https://nces.ed.gov/collegenavigator/>.

**Absolute Priority 5: Institutions Serving High Percentages of Graduate Students:**

**Background:** Finally, the Department is establishing Absolute Priority 5 to provide additional support to institutions with high percentages of graduate students. Congress specified in section 2003(a)(3) of the ARP that, in allocating funds to institutions with the greatest unmet need due to the coronavirus, the Department should consider institutions with large populations of graduate students. Accordingly, under this priority, the Department is awarding funds to eligible institutions for which graduate students comprise 90 percent or more of their student population according to Fall 2020 enrollment data provided in IPEDS. This threshold of 90 percent reflects the Department's goal of targeting funds to institutions with large graduate populations since the weighing of the main ARP formula toward Pell recipients meant that these institutions did not receive sufficient awards relative to the size of their student body. However, because some standalone graduate schools may have small undergraduate offerings, we have chosen 90 percent as a threshold to ensure we do not exclude a college that is primarily a graduate institution, but which also serves a limited number of

<sup>5</sup> Table 6, [www.census.gov/data/tables/2021/demo/hhp/hhp27.html](http://www.census.gov/data/tables/2021/demo/hhp/hhp27.html).

undergraduate students. Depending on the number of applications received, the Department may prioritize institutions that did not receive funds under SAIHE.

**Absolute Priority 5:** The Department invites applications from eligible institutions for which graduate students comprise 90 percent or more of their student population according to Fall 2020 enrollment data provided in IPEDS.

**Award amounts:** For Absolute Priority 5, the Department will use the number of graduate students enrolled at the institution as reported in IPEDS (using Fall 2020 enrollment) to calculate the allocation.

**Student Grant Minimum:** Grantees under this priority must use all funds awarded to make Emergency Financial Aid Grants to graduate Students.

**Definitions:** For the FY 2022 grant competition we are establishing the following definitions of “community college” and “Minority Serving Institution,” in accordance with section 437(d)(1) of GEPA, 20 U.S.C. 1232(d)(1).

**Community college** means an institution that meets the definition in section 312(f) of the HEA (20 U.S.C. 1058(f)) or an IHE (as defined in section 101 of the HEA) that awards degrees and certificates, more than 50 percent of which are not bachelor’s degrees (or an equivalent) or master’s, professional, or other advanced degrees.

**Minority-Serving Institution** means an institution that is eligible to receive assistance under sections 316 through 320 of part A of title III, under part B of title III, or under title V of the HEA.

**Waiver of Proposed Rulemaking:** Under the Administrative Procedure Act (5 U.S.C. 553), the Department generally offers interested parties the opportunity to comment on proposed priorities and definitions. Section 437(d)(1) of GEPA, however, allows the Secretary to exempt from rulemaking requirements regulations governing the first grant competition under a new or substantially revised program authority. This is the first grant competition for this program under section 2003 of ARP, as incorporating CRRSAA section 314(a)(3), and therefore qualifies for this exemption. In order to ensure timely grant awards, the Secretary has decided to forgo formal public comment under the Administrative Procedure Act on the priorities and definitions under section 437(d)(1) of GEPA. These priorities and definitions will apply to the FY 2022 grant competition and any subsequent year in which we make awards from the list of unfunded applications from this competition.

**Program Authority:** CRRSAA section 314(a)(3) and ARP section 2003.

**Note:** Projects will be awarded and must be operated in a manner consistent with the nondiscrimination requirements contained in Federal civil rights laws.

**Applicable Regulations:** (a) The Education Department General Administrative Regulations in 34 CFR parts 75, 77, 79, 81, 82, 84, 86, 97, 98, and 99. (b) The Office of Management and Budget Guidelines to Agencies on Governmentwide Debarment and Suspension (Nonprocurement) in 2 CFR part 180, as adopted and amended as regulations of the Department in 2 CFR part 3485. (c) The Uniform Administrative Requirements, Cost Principles, and Audit Requirements for Federal Awards in 2 CFR part 200, as adopted and amended as regulations of the Department in 2 CFR part 3474.

**Note:** The regulations in 34 CFR part 86 apply to institutions of higher education only.

## II. Award Information

**Type of Award:** Discretionary grants.  
**Estimated Available Funds:** \$197,922,850.

**Estimated Award Amounts and Number of Awards:** The award amounts will depend on the absolute priority or priorities under which an institution is applying. The award amounts and number of awards will also depend on the number of applications received under each priority. At the time at which we make awards, the Department will post an allocation table with award amounts and amounts subject to the use-of-funds restrictions under the applicable priorities. See the *Absolute Priorities* section of this notice for more information.

Should requests for funding exceed the amount available under the ARP (a)(3) program, the Department reserves the right to make ratable reductions for any awards under Absolute Priorities 1–3 and to determine the amount of funding needed to support each of the absolute priorities based on applications received. For Absolute Priorities 4 and 5, the Department may prioritize awards to applicants that did not receive funding under SAIHE, depending on the number of applications received.

In making awards under Absolute Priority 4, the Department may also give priority to eligible applicants in the following order:

**Tier 1:** Community colleges; and  
**Tier 2:** Other public and private nonprofit IHEs in rural settings.

Depending on the funds available for this absolute priority, some applicants may not be funded based on tier rankings. An IHE must complete Section

5 of the Profile form for this absolute priority.

**Project Period:** Up to 12 months.

**Note:** The Department is not bound by any estimates in this notice.

## III. Eligibility Information

1. **Eligible Applicants:** Eligible applicants are IHEs (as defined in section 101 of the HEA (20 U.S.C. 1001)) that are public or private non-profit IHEs that meet the eligibility requirements specified in the absolute priority or priorities under which the applicant applies. With the exception of Absolute Priority 2(c), institutional eligibility is based on the six-digit OPEID.

2. **Cost Sharing or Matching:** This program does not require cost sharing or matching.

3. **Subgrantees:** A grantee under this competition may not award subgrants to entities to directly carry out project activities described in its application.

4. **Uses of Funds:** Unless noted otherwise, in accordance with section 2003 of the ARP, grantees may use these grant funds for their institutional costs to defray expenses associated with coronavirus (including lost revenue, reimbursement for expenses already incurred, technology costs associated with a transition to distance education, faculty and staff trainings, and payroll); and to make additional Emergency Financial Grants to Students, which may be used for any component of the student’s cost of attendance or for emergency costs that arise due to coronavirus, such as tuition, food, housing, health care (including mental health care), and child care.

Additionally, no funds received by an IHE under this section may be used to fund contractors for the provision of pre-enrollment recruitment activities; marketing or recruitment; endowments; capital outlays associated with facilities related to athletics, sectarian instruction, or religious worship; senior administrator or executive salaries, benefits, bonuses, contracts, incentives; stock buybacks, shareholder dividends, capital distributions, and stock options; or any other cash or other benefit for a senior administrator or executive.

Furthermore, in accordance with ARP section 2003(5), an institution that has not previously received ARP (a)(1) or (a)(2) funding must use a portion of funds received under any of the absolute priorities in this competition to (A) implement evidence-based practices to monitor and suppress coronavirus in accordance with public health guidelines; and (B) conduct direct outreach to financial aid applicants about the opportunity to receive a

financial aid adjustment due to the recent unemployment of a family member or independent student, or other circumstances, described in section 479A.

Finally, grantees under certain priorities are required to expend a certain percentage of funds on Emergency Financial Aid Grants to Students. The Department will publish an ARP (a)(3) allocation table will identify the minimum amount that each institution must spend on Emergency Financial Aid Grants to Students amounts at the time of award.

#### IV. Application and Submission Information

##### 1. Application Submission

*Instructions:* Applicants are required to follow the Common Instructions for Applicants to Department of Education Discretionary Grant Programs, published in the **Federal Register** on December 27, 2021 (86 FR 73264) and available at [www.federalregister.gov/d/2021-27979](http://www.federalregister.gov/d/2021-27979), which contain requirements and information on how to submit an application. Please note that these Common Instructions supersede the version published on February 13, 2019, and, in part, describe the transition from applicants using a DUNS Number to the Unique Entity Identifier (UEI). More information on the phase-out of the DUNS Number is available here: [www2.ed.gov/about/offices/list/fofo/docs/unique-entity-identifier-transition-fact-sheet.pdf](http://www2.ed.gov/about/offices/list/fofo/docs/unique-entity-identifier-transition-fact-sheet.pdf).

*2. Intergovernmental Review:* This competition is subject to Executive Order 12372 and the regulations in 34 CFR part 79. However, under 34 CFR 79.8(a), we waive intergovernmental review in order to make awards in a timely manner.

*3. Funding Restrictions:* We reference regulations outlining funding restrictions in the *Applicable Regulations* sections of this notice. We describe requirements relating to the uses of funds, including funding restrictions, under this program in the Uses of Funds section of this notice.

*4. Recommended Page Limit:* The application for this program includes the Standard Form 424, the Certificate and Agreement, and the SSARP Program Profile Information Form. The project narrative form in *grants.gov* is where you, the applicant, will include the Certificate and Agreement for this program and the SSARP Program Profile Information Form.

*5. Program Profile Information Form:* Applicants must complete the Program Profile Information Form and submit the form under the program narrative form in *grants.gov*.

#### V. Application Review Information

*1. Review and Selection Process:* We remind potential applicants that in reviewing applications in any discretionary grant competition, the Secretary may consider, under 34 CFR 75.217(d)(3), the past performance of the applicant in carrying out a previous award, such as the applicant's use of funds, achievement of project objectives, and compliance with grant conditions. The Secretary may also consider whether the applicant failed to submit a timely performance report or submitted a report of unacceptable quality.

In addition, in making a competitive grant award, the Secretary requires various assurances, including those applicable to Federal civil rights laws that prohibit discrimination in programs or activities receiving Federal financial assistance from the Department (34 CFR 100.4, 104.5, 106.4, 108.8, and 110.23).

For this competition, the Department has waived the peer review process for this program. Department staff will review eligible applications using the criteria specified in the applicable absolute priority or priorities.

*2. Risk Assessment and Specific Conditions:* Consistent with 2 CFR 200.206, before awarding grants under this competition the Department conducts a review of the risks posed by applicants. Under 2 CFR 200.208, the Secretary may impose specific conditions and, under 2 CFR 3474.10, in appropriate circumstances, high-risk conditions on a grant if the applicant or grantee is not financially stable; has a history of unsatisfactory performance; has a financial or other management system that does not meet the standards in 2 CFR part 200, subpart D; has not fulfilled the conditions of a prior grant; or is otherwise not responsible.

*3. Integrity and Performance System:* If you are selected under this competition to receive an award that over the course of the project period may exceed the simplified acquisition threshold (currently \$250,000), under 2 CFR 200.206(a)(2) we must make a judgment about your integrity, business ethics, and record of performance under Federal awards—that is, the risk posed by you as an applicant—before we make an award. In doing so, we must consider any information about you that is in the integrity and performance system (currently referred to as the Federal Awardee Performance and Integrity Information System (FAPIIS)), accessible through the System for Award Management. You may review and comment on any information about yourself that a Federal agency

previously entered and that is currently in FAPIIS.

Please note that, if the total value of your currently active grants, cooperative agreements, and procurement contracts from the Federal Government exceeds \$10,000,000, the reporting requirements in 2 CFR part 200, Appendix XII, require you to report certain integrity information to FAPIIS semiannually. Please review the requirements in 2 CFR part 200, Appendix XII, if this grant plus all the other Federal funds you receive exceed \$10,000,000.

*4. In General:* In accordance with the Office of Management and Budget's guidance located at 2 CFR part 200, all applicable Federal laws, and relevant Executive guidance, the Department will review and consider applications for funding pursuant to this notice inviting applications in accordance with:

(a) Selecting recipients most likely to be successful in delivering results based on the program objectives through an objective process of evaluating Federal award applications (2 CFR 200.205);

(b) Prohibiting the purchase of certain telecommunication and video surveillance services or equipment in alignment with section 889 of the National Defense Authorization Act of 2019 (Pub. L. 115–232) (2 CFR 200.216);

(c) Providing a preference, to the extent permitted by law, to maximize use of goods, products, and materials produced in the United States (2 CFR 200.322); and

(d) Terminating agreements in whole or in part to the greatest extent authorized by law if an award no longer effectuates the program goals or agency priorities (2 CFR 200.340).

#### VI. Award Administration Information

*1. Award Notices:* If your application is successful, the individuals listed as the Authorizing Representative and Director will receive a Grant Award Notification (GAN); or we may send you an email containing a link to access an electronic version of your GAN.

If your application is not evaluated or not selected for funding, we will notify you.

*2. Administrative and National Policy Requirements:* We identify administrative and national policy requirements in the application package and reference these and other requirements in the *Applicable Regulations* section of this notice.

We reference the regulations outlining the terms and conditions of an award in the *Applicable Regulations* section of this notice and include these and other specific conditions in the GAN. The GAN also incorporates your approved

application as part of your binding commitments under the grant.

3. *Reporting:* (a) Institutions receiving a grant under this program must report their expenditures using the HEERF Public Quarterly Reporting Form and the HEERF Annual Report. More information is available at [www2.ed.gov/about/offices/list/ope/heerfreporting.html](http://www2.ed.gov/about/offices/list/ope/heerfreporting.html).

(b) At the end of your project period, you must submit a final performance report, including financial information, as directed by the Secretary. If you receive a multiyear award, you must submit an annual performance report that provides the most current performance and financial expenditure information as directed by the Secretary under 34 CFR 75.118. The Secretary may also require more frequent performance reports under 34 CFR 75.720(c).

## VII. Other Information

*Accessible Format:* On request to the program contact person listed under **FOR FURTHER INFORMATION CONTACT**, individuals with disabilities can obtain this document and a copy of the application package in an accessible format. The Department will provide the requestor with an accessible format that may include Rich Text Format (RTF) or text format (txt), a thumb drive, an MP3 file, braille, large print, audiotape, or compact disc, or other accessible format.

*Electronic Access to This Document:* The official version of this document is the document published in the **Federal Register**. You may access the official edition of the **Federal Register** and the Code of Federal Regulations at [www.govinfo.gov](http://www.govinfo.gov). At this site you can view this document, as well as all other documents of this Department published in the **Federal Register**, in text or Portable Document Format (PDF). To use PDF, you must have Adobe Acrobat Reader, which is available free at the site.

You may also access documents of the Department published in the **Federal Register** by using the article search feature at: [www.federalregister.gov](http://www.federalregister.gov). Specifically, through the advanced search feature at this site, you can limit your search to documents published by the Department.

### Michelle Asha Cooper,

*Deputy Assistant Secretary for Higher Education Programs, Delegated the Authority to Perform the Functions and Duties of the Assistant Secretary, Office of Postsecondary Education.*

[FR Doc. 2022-02338 Filed 2-2-22; 8:45 am]

BILLING CODE 4000-01-P

## DEPARTMENT OF EDUCATION

### Notice Inviting Applications for Public and Private Nonprofit Institutions of Higher Education Under the Higher Education Emergency Relief Fund (HEERF), Section 2003 of the American Rescue Plan Act, 2021 (ARP)

**AGENCY:** Office of Postsecondary Education, Department of Education.

**ACTION:** Notice; reopening of application period.

**SUMMARY:** The U.S. Department of Education is reopening the application period for institutions of higher education (IHEs) eligible for HEERF, ARP Act funds under the grant funding provided in **SUPPLEMENTARY INFORMATION**. The Secretary takes this action to allow eligible applicants additional time to submit their Certifications and Agreements (applications), and associated data submissions for approved information collections.

#### DATES:

*Deadline for transmittal of applications:* Applications will be accepted on a rolling basis until March 7, 2022.

*Deadline for submission of RPIC form:* March 7, 2022.

#### FOR FURTHER INFORMATION CONTACT:

Karen Epps, U.S. Department of Education, 400 Maryland Avenue SW, Room 2B133, Washington, DC 20202. Telephone: The Department of Education HEERF Call Center at (202) 377-3711. Email: [HEERF@ed.gov](mailto:HEERF@ed.gov). Please also visit our HEERF website at: [www2.ed.gov/about/offices/list/ope/arp.html](http://www2.ed.gov/about/offices/list/ope/arp.html).

If you use a telecommunications device for the deaf (TDD) or a text telephone (TTY), call the Federal Relay Service (FRS), toll free, at 1-800-877-8339.

**SUPPLEMENTARY INFORMATION:** The U.S. Department of Education is reopening the application period for institutions of higher education (IHEs) eligible for HEERF, ARP Act funds under the grant funding streams:

- ARP (a)(1) HEERF grant funding as authorized under section 2003(1) of the ARP (Assistance Listing Numbers (ALNs) 84.425E and 84.425F);
- ARP (a)(2) HEERF grant funding as authorized under ARP section 2003(2) for MSI and SIP institutions (ALNs 84.425L, and 84.425M); and
- ARP (a)(4) grant funding under the Proprietary Institution Grant Funds for Students Program (ALN 84.425Q).

The Secretary takes this action to allow eligible applicants additional time

to submit their Certifications and Agreements (applications), and associated data submissions for approved information collections under OMB control numbers 1801-0005, 1840-0842, 1840-0843, 1840-0852, and 1840-0855.

This notice reopens the period for transmittal of applications for all eligible applicants that appear on the published allocation tables for ARP (a)(1), (a)(2) SIP and MSI, and ARP (a)(4) funding, along with the Required Proprietary Institution Certification (RPIC) until March 7, 2022. Please note that institutions that are not included on the ARP(a)(1) and (a)(2) allocation tables, but that are eligible institutions, may apply under the Supplemental Support Under the American Rescue Plan (SSARP) funding opportunity.

*ARP HEERF (a)(1):* On May 13, 2021, the Secretary announced in the **Federal Register** (86 FR 26215) the availability of new ARP (a)(1) HEERF grant funding as authorized under section 2003(1) of the ARP and invited applications under Assistance Listing Numbers (ALN) 84.425E and 84.425F from eligible public and private nonprofit institutions that did not previously receive funding under section 314(a)(1) of the Coronavirus Response and Relief Supplemental Appropriations Act, 2021 (CRRSAA).

*ARP HEERF (a)(2):* On August 2, 2021, the Secretary announced in the **Federal Register** (86 FR 41459) the availability of new HEERF funding for the ARP (a)(2) grant program authorized under the ARP section 2003(2) Strengthening Institutions Program and invited applications under Assistance Listing Number (ALN) 84.425M from eligible public and private nonprofit IHEs to address needs directly related to the coronavirus. These awards were in addition to the ARP (a)(1) grant funds and were allocated by the Secretary proportionally based on the relative share of funding appropriated to SIP in the Further Consolidated Appropriations Act, 2020. The IHEs eligible for this funding include institutions eligible for SIP that did not receive funding under section 314(a)(2) of the CRRSAA and that are included in the ARP (a)(2) allocation table.

In addition, on August 2, 2021, the Secretary announced in the **Federal Register** (86 FR 41454) the availability of new HEERF funding for the ARP (a)(2) grant program authorized under ARP section 2003(2) Minority Serving Institutions program and invited applications under Assistance Listing Number (ALN) 84.425L from eligible public and private nonprofit IHEs to address needs directly related to the

coronavirus. These awards were in addition to the ARP (a)(1) grants and were allocated by the Secretary proportionally to funding for MSI programs in the Further Consolidated Appropriations Act, 2020. The institutions eligible for this funding include institutions that generally would be eligible to apply for the following grant programs under the Higher Education Act of 1965, as amended (HEA), and that are listed on the ARP (a)(2) MSI Allocation Table: Title V, part A Developing Hispanic Serving Institutions, Title V, part B Promoting Postbaccalaureate Opportunities for Hispanic Americans, and the following Title III Part A programs: Strengthening Asian American and Native American Pacific Islander-Serving Institutions (AANAPISI), Strengthening Alaska Native and Native Hawaiian-Serving Institutions (ANNH), Strengthening Native American-Serving Nontribal Institutions (NASNTI), and Strengthening Predominantly Black Institutions (PBI).

*ARP HEERF (a)(4)*: Lastly, on May 13, 2021, the Department published in the **Federal Register** (86 FR 26210) a notice announcing the availability of funds and application deadlines for the ARP (a)(4) grant funding and the RPIC form for Supplemental ARP (a)(4) awards under the Proprietary Institution Grant Funds for Students Program, ALN 84.425Q, as authorized under section 2003 of the ARP. The Department also announced that it would award supplemental funds to eligible institutions that previously received a CRRSAA section 314(a)(4) award, ALN 84.425Q, without requiring these institutions to submit a new application for funding. However, prior to receiving an award, eligible institutions were required to submit an RPIC form signed by the institution's president or chief executive officer and any owners with an ownership interest in the institution of 25 percent or more.

Each application for an ARP (a)(1), (a)(2), and (a)(4) grant must include—

- A complete SF-424;
- The Supplemental Information for the SF-424 form;
- The applicable Certification and Agreement (C&A).

Each application for an ARP (a)(4) grant must also include a complete RPIC form, available at [www2.ed.gov/about/offices/list/ope/arp.html](http://www2.ed.gov/about/offices/list/ope/arp.html).

The Department reopens the period for transmittal of applications for all eligible applicants for ARP (a)(1), ARP (a)(2) SIP and MSI, and ARP (a)(4) funding, along with the Required Proprietary Institution Certification (RPIC) until March 7, 2022.

We will accept complete applications submitted at any time prior to the deadline on March 7, 2022. All other requirements and conditions stated in the aforementioned notices announcing availability of funds remain the same.

*Program Authority*: Section 2003 of the ARP and section 314 of the CRRSAA.

*Accessible Format*: On request to the program contact person listed under **FOR FURTHER INFORMATION CONTACT**, individuals with disabilities can obtain this document and a copy of the application package in an accessible format. The Department will provide the requestor with an accessible format that may include Rich Text Format (RTF) or text format (txt), a thumb drive, an MP3 file, braille, large print, audiotape, or compact disc or other accessible format.

*Electronic Access to This Document*: The official version of this document is the document published in the **Federal Register**. You may access the official edition of the **Federal Register** and the Code of Federal Regulations at [www.govinfo.gov](http://www.govinfo.gov). At this site you can view this document, as well as all other documents of this Department published in the **Federal Register**, in text or Portable Document Format (PDF). To use PDF you must have Adobe Acrobat Reader, which is available free through a link at the site.

You may also access documents of the Department published in the **Federal Register** by using the article search feature at [www.federalregister.gov](http://www.federalregister.gov). Specifically, through the advanced search feature at this site, you can limit your search to documents published by the Department.

**Michelle Asha Cooper,**

*Deputy Assistant Secretary for Higher Education Programs Delegated the Authority to Perform the Functions and Duties of the Assistant Secretary, Office of Postsecondary Education.*

[FR Doc. 2022-02339 Filed 2-2-22; 8:45 am]

**BILLING CODE 4000-01-P**

## DEPARTMENT OF ENERGY

### Federal Energy Regulatory Commission

[Project No. 2212-055]

#### Domtar Paper Company, LLC; Notice of Application Accepted for Filing and Soliciting Comments, Motions To Intervene, and Protests

Take notice that the following hydroelectric application has been filed with the Commission and is available for public inspection:

- a. *Type of Application*: Non-Capacity Amendment of License.
- b. *Project No.*: 2212-055.
- c. *Date Filed*: November 22, 2021.
- d. *Applicant*: Domtar Paper Company, LLC.
- e. *Name of Project*: Rothschild Hydroelectric Project.
- f. *Location*: The project is located on the Wisconsin River in Marathon County, Wisconsin.
- g. *Filed Pursuant to*: Federal Power Act 16 U.S.C. 791a-825r.
- h. *Applicant Contact*: Mr. Steven Lewens, Environmental Health & Safety Manager-Rothschild, Domtar Paper Company, LLC, 200 North Grand Avenue, Rothschild, WI 54474; (715) 355-6268; [Steven.Lewens@domtar.com](mailto:Steven.Lewens@domtar.com).
- i. *FERC Contact*: Linda Stewart, (202) 502-8184, [linda.stewart@ferc.gov](mailto:linda.stewart@ferc.gov).
- j. *Deadline for filing comments, motions to intervene, and protests*: February 28, 2022.

The Commission strongly encourages electronic filing. Please file comments, motions to intervene, and protests using the Commission's eFiling system at <http://www.ferc.gov/docs-filing/efiling.asp>. Commenters can submit brief comments up to 6,000 characters, without prior registration, using the eComment system at <http://www.ferc.gov/docs-filing/ecomment.asp>. You must include your name and contact information at the end of your comments. For assistance, please contact FERC Online Support at [FERCOnlineSupport@ferc.gov](mailto:FERCOnlineSupport@ferc.gov), (866) 208-3676 (toll free), or (202) 502-8659 (TTY). In lieu of electronic filing, you may submit a paper copy. Submissions sent via the U.S. Postal Service must be addressed to: Kimberly D. Bose, Secretary, Federal Energy Regulatory Commission, 888 First Street NE, Room 1A, Washington, DC 20426. Submissions sent via any other carrier must be addressed to: Kimberly D. Bose, Secretary, Federal Energy Regulatory Commission, 12225 Wilkins Avenue, Rockville, Maryland 20852. The first page of any filing should include the docket number P-2212-055. Comments emailed to Commission staff are not considered part of the Commission record.

The Commission's Rules of Practice and Procedure require all intervenors filing documents with the Commission to serve a copy of that document on each person whose name appears on the official service list for the project. Further, if an intervenor files comments or documents with the Commission relating to the merits of an issue that may affect the responsibilities of a particular resource agency, it must also



serve a copy of the document on that resource agency.

k. *Description of Request:* Domtar Paper Company, LLC (licensee) has determined that the repair of five inoperable turbine generating units (Units 1, 2, 4, 5, and 6) is not cost effective, and therefore, proposes to retire the five units in place. The other two turbine generating units at the project (Units 3 and 7) would remain in service, with no changes proposed by the licensee. To retire the five units, the licensee proposes to disconnect the generator leads from the units. All proposed activity would occur in the powerhouse, with no ground disturbing activity necessary. With both the powerhouse and the spillway section of the dam currently releasing flows into the main channel of the Wisconsin River downstream, the proposal would result in a reduced flow through the powerhouse and an increased flow over the spillway. The proposal would decrease the total authorized capacity of the project from 3,708 to 948 kilowatts and would decrease the hydraulic capacity from 3,850 to 1,100 cubic feet per second.

l. *Locations of the Application:* This filing may be viewed on the Commission's website at <http://www.ferc.gov> using the "eLibrary" link. Enter the docket number excluding the last three digits in the docket number field to access the document. You may also register online at <http://www.ferc.gov/docs-filing/esubscription.asp> to be notified via email of new filings and issuances related to this or other pending projects. For assistance, call 1-866-208-3676 or email [FERCOnlineSupport@ferc.gov](mailto:FERCOnlineSupport@ferc.gov), for TTY, call (202) 502-8659. Agencies may obtain copies of the application directly from the applicant.

m. Individuals desiring to be included on the Commission's mailing list should so indicate by writing to the Secretary of the Commission.

n. *Comments, Protests, or Motions to Intervene:* Anyone may submit comments, a protest, or a motion to intervene in accordance with the requirements of Rules of Practice and Procedure, 18 CFR 385.210, .211, .214, respectively. In determining the appropriate action to take, the Commission will consider all protests or other comments filed, but only those who file a motion to intervene in accordance with the Commission's Rules may become a party to the proceeding. Any comments, protests, or motions to intervene must be received on or before the specified comment date for the particular application.

o. *Filing and Service of Documents:* Any filing must (1) bear in all capital letters the title "COMMENTS", "PROTEST", or "MOTION TO INTERVENE" as applicable; (2) set forth in the heading the name of the applicant and the project number of the application to which the filing responds; (3) furnish the name, address, and telephone number of the person commenting, protesting, or intervening; and (4) otherwise comply with the requirements of 18 CFR 385.2001 through 385.2005. All comments, motions to intervene, or protests must set forth their evidentiary basis. Any filing made by an intervenor must be accompanied by proof of service on all persons listed in the service list prepared by the Commission in this proceeding, in accordance with 18 CFR 385.2010.

Dated: January 27, 2022.

**Kimberly D. Bose,**  
Secretary.

[FR Doc. 2022-02153 Filed 2-2-22; 8:45 am]

**BILLING CODE 6717-01-P**

## DEPARTMENT OF ENERGY

### Federal Energy Regulatory Commission

[Docket No. CP22-40-000]

#### Eastern Shore Natural Gas; Notice of Request Under Blanket Authorization and Establishing Intervention and Protest Deadline

Take notice that on January 18, 2022 Eastern Shore Natural Gas (Eastern Shore) filed a prior notice request for authorization, in accordance with 18 CFR Sections 157.203(c), 157.205(b), 157.208(c) and 157.210 of the Federal Energy Regulatory Commission's (Commission) regulations under the Natural Gas Act and Eastern Shore's blanket certificate issued in Docket Nos. CP96-128-000, et al., to install an additional compressor unit, adding 1,875 horse power of new compression at Eastern Shore's existing Bridgeville Compressor Station site in Sussex County, DE and appurtenant facilities required to provide additional firm natural gas transportation service of 7,300 dekatherms per day to an existing shipper on Eastern Shore's pipeline system, and estimates that the cost of the project will be about \$14,026,800, all as more fully set forth in the application which is on file with the Commission and open for public inspection.

In addition to publishing the full text of this document in the **Federal**

**Register**, the Commission provides all interested persons an opportunity to view and/or print the contents of this document via the internet through the Commission's Home Page (<http://ferc.gov>) using the "eLibrary" link. Enter the docket number excluding the last three digits in the docket number field to access the document. At this time, the Commission has suspended access to the Commission's Public Reference Room, due to the proclamation declaring a National Emergency concerning the Novel Coronavirus Disease (COVID-19), issued by the President on March 13, 2020. For assistance, contact the Federal Energy Regulatory Commission at [FERCOnlineSupport@ferc.gov](mailto:FERCOnlineSupport@ferc.gov) or call toll-free, (886) 208-3676 or TTY, (202) 502-8659.

Any questions concerning this application should be directed to Jeffrey R. Tietbohl, Vice President, Eastern Shore Natural Gas Company, 500 Energy Lane, Suite 200 Dover, Delaware 19901 at (302)-363-4679 or email at [jtietbohl@esng.com](mailto:jtietbohl@esng.com) or [pipelines@chpk.com](mailto:pipelines@chpk.com).

Pursuant to Section 157.9 of the Commission's Rules of Practice and Procedure,<sup>1</sup> within 90 days of this Notice the Commission staff will either: complete its environmental review and place it into the Commission's public record (eLibrary) for this proceeding; or issue a Notice of Schedule for Environmental Review. If a Notice of Schedule for Environmental Review is issued, it will indicate, among other milestones, the anticipated date for the Commission staff's issuance of the final environmental impact statement (FEIS) or environmental assessment (EA) for this proposal. The filing of an EA in the Commission's public record for this proceeding or the issuance of a Notice of Schedule for Environmental Review will serve to notify federal and state agencies of the timing for the completion of all necessary reviews, and the subsequent need to complete all federal authorizations within 90 days of the date of issuance of the Commission staff's FEIS or EA.

#### Public Participation

There are three ways to become involved in the Commission's review of this project: you can file a protest to the project, you can file a motion to intervene in the proceeding, and you can file comments on the project. There is no fee or cost for filing protests, motions to intervene, or comments. The deadline for filing protests, motions to intervene, and comments is 5:00 p.m. Eastern Time on March 29, 2022. How

<sup>1</sup> 18 CFR (Code of Federal Regulations) § 157.9.

to file protests, motions to intervene, and comments is explained below.

#### Protests

Pursuant to section 157.205 of the Commission's regulations under the NGA,<sup>2</sup> any person<sup>3</sup> or the Commission's staff may file a protest to the request. If no protest is filed within the time allowed or if a protest is filed and then withdrawn within 30 days after the allowed time for filing a protest, the proposed activity shall be deemed to be authorized effective the day after the time allowed for protest. If a protest is filed and not withdrawn within 30 days after the time allowed for filing a protest, the instant request for authorization will be considered by the Commission.

Protests must comply with the requirements specified in section 157.205(e) of the Commission's regulations,<sup>4</sup> and must be submitted by the protest deadline, which is March 29, 2022. A protest may also serve as a motion to intervene so long as the protestor states it also seeks to be an intervenor.

#### Interventions

Any person has the option to file a motion to intervene in this proceeding. Only intervenors have the right to request rehearing of Commission orders issued in this proceeding and to subsequently challenge the Commission's orders in the U.S. Circuit Courts of Appeal.

To intervene, you must submit a motion to intervene to the Commission in accordance with Rule 214 of the Commission's Rules of Practice and Procedure<sup>5</sup> and the regulations under the NGA<sup>6</sup> by the intervention deadline for the project, which is March 29, 2022. As described further in Rule 214, your motion to intervene must state, to the extent known, your position regarding the proceeding, as well as your interest in the proceeding. For an individual, this could include your status as a landowner, ratepayer, resident of an impacted community, or recreationist. You do not need to have property directly impacted by the project in order to intervene. For more information about motions to intervene, refer to the FERC website at <https://www.ferc.gov/resources/guides/how-to/intervene.asp>.

All timely, unopposed motions to intervene are automatically granted by

operation of Rule 214(c)(1). Motions to intervene that are filed after the intervention deadline are untimely and may be denied. Any late-filed motion to intervene must show good cause for being late and must explain why the time limitation should be waived and provide justification by reference to factors set forth in Rule 214(d) of the Commission's Rules and Regulations. A person obtaining party status will be placed on the service list maintained by the Secretary of the Commission and will receive copies (paper or electronic) of all documents filed by the applicant and by all other parties.

#### Comments

Any person wishing to comment on the project may do so. The Commission considers all comments received about the project in determining the appropriate action to be taken. To ensure that your comments are timely and properly recorded, please submit your comments on or before March 29, 2022. The filing of a comment alone will not serve to make the filer a party to the proceeding. To become a party, you must intervene in the proceeding.

#### How to File Protests, Interventions, and Comments

There are two ways to submit protests, motions to intervene, and comments. In both instances, please reference the Project docket number CP22-40-000 in your submission.

(1) You may file your protest, motion to intervene, and comments by using the Commission's eFiling feature, which is located on the Commission's website ([www.ferc.gov](http://www.ferc.gov)) under the link to Documents and Filings. New eFiling users must first create an account by clicking on "eRegister." You will be asked to select the type of filing you are making; first select "General" and then select "Protest", "Intervention", or "Comment on a Filing"; or<sup>7</sup>

(2) You can file a paper copy of your submission by mailing it to the address below. Your submission must reference the Project docket number CP22-40-000.

To mail via USPS, use the following address: Kimberly D. Bose, Secretary, Federal Energy Regulatory Commission, 888 First Street NE, Washington, DC 20426

To mail via any other courier, use the following address: Kimberly D. Bose,

Secretary, Federal Energy Regulatory Commission, 12225 Wilkins Avenue, Rockville, Maryland 20852

The Commission encourages electronic filing of submissions (option 1 above) and has eFiling staff available to assist you at (202) 502-8258 or [FercOnlineSupport@ferc.gov](mailto:FercOnlineSupport@ferc.gov).

Protests and motions to intervene must be served on the applicant either by mail or email (with a link to the document) at: Jeffrey R. Tietbohl, Vice President, Eastern Shore Natural Gas Company, 500 Energy Lane, Suite 200 Dover, Delaware 19901 at (302)-363-4679 or email at [jtietbohl@esng.com](mailto:jtietbohl@esng.com) or [pipelines@chpk.com](mailto:pipelines@chpk.com).

Any subsequent submissions by an intervenor must be served on the applicant and all other parties to the proceeding. Contact information for parties can be downloaded from the service list at the eService link on FERC Online.

#### Tracking the Proceeding

Throughout the proceeding, additional information about the project will be available from the Commission's Office of External Affairs, at (866) 208-FERC, or on the FERC website at [www.ferc.gov](http://www.ferc.gov) using the "eLibrary" link as described above. The eLibrary link also provides access to the texts of all formal documents issued by the Commission, such as orders, notices, and rulemakings.

In addition, the Commission offers a free service called eSubscription which allows you to keep track of all formal issuances and submittals in specific dockets. This can reduce the amount of time you spend researching proceedings by automatically providing you with notification of these filings, document summaries, and direct links to the documents. For more information and to register, go to [www.ferc.gov/docs-filing/esubscription.asp](http://www.ferc.gov/docs-filing/esubscription.asp).

Dated: January 28, 2022.

**Kimberly D. Bose,**  
Secretary.

[FR Doc. 2022-02218 Filed 2-2-22; 8:45 am]

BILLING CODE 6717-01-P

## DEPARTMENT OF ENERGY

### Federal Energy Regulatory Commission

[Docket No. CP22-41-000]

#### Cameron LNG, LLC; Notice of Application for Amendment and Establishing Intervention Deadline

Take notice that on January 18, 2021, Cameron LNG, LLC (Cameron LNG),

<sup>2</sup> 18 CFR 157.205.

<sup>3</sup> Persons include individuals, organizations, businesses, municipalities, and other entities. 18 CFR 385.102(d).

<sup>4</sup> 18 CFR 157.205(e).

<sup>5</sup> 18 CFR 385.214.

<sup>6</sup> 18 CFR 157.10.

<sup>7</sup> Additionally, you may file your comments electronically by using the eComment feature, which is located on the Commission's website at [www.ferc.gov](http://www.ferc.gov) under the link to Documents and Filings. Using eComment is an easy method for interested persons to submit brief, text-only comments on a project.

2925 Briarpark Drive, Suite 1000, Houston, Texas 77042, filed an application under section 3(a) of the Natural Gas Act (NGA) requesting an amendment to its May 5, 2016 Order<sup>1</sup> (2016 Order) to site, construct, and operate facilities to provide additional natural gas processing, storage, and liquefaction capacity at the existing site of the Cameron LNG liquefied natural gas terminal located in Cameron and Calcasieu Parishes, Louisiana (Amended Expansion Project). The proposed enhancements will reduce greenhouse gas (GHG) emissions from Train 4, will allow to access carbon capture and sequestration (CCS) facilities that may be developed in the region in the future, and will enhance the production capacity of Train 4.

Cameron LNG also proposes a partial vacatur of the 2016 Order to exclude the construction and operation of Train 5 and a fifth LNG storage tank.<sup>2</sup> With the removal of Train 5, the overall maximum production capacity of the Amended Expansion Project will be reduced from 9.97 MTPA to 6.75 MTPA, sourced exclusively from Train 4. The resultant total output capacity of the Cameron LNG terminal would be reduced from 24.95 MTPA (in service Trains 1–3 and Trains 4 & 5 which are approved but not in-service) to 21.7 MTPA (in service Trains 1–3 and enhanced Train 4).

In addition to publishing the full text of this document in the **Federal Register**, the Commission provides all interested persons an opportunity to view and/or print the contents of this document via the internet through the Commission's Home Page (<http://ferc.gov>) using the "eLibrary" link. Enter the docket number excluding the last three digits in the docket number field to access the document. At this time, the Commission has suspended access to the Commission's Public Reference Room, due to the proclamation declaring a National Emergency concerning the Novel Coronavirus Disease (COVID-19), issued by the President on March 13, 2020. For assistance, contact the Federal Energy Regulatory Commission at [FERCOnlineSupport@ferc.gov](mailto:FERCOnlineSupport@ferc.gov) or call toll-free, (886) 208-3676 or TYY, (202) 502-8659.

Any questions regarding the proposed project should be directed to Blair

Woodward, General Counsel, Cameron LNG, LLC, 2925 Briarpark Drive, Suite 1000 Houston, TX 77042, (832) 783-5582, [bwoodward@cameronlng.com](mailto:bwoodward@cameronlng.com); or Brett A. Snyder or Lamiya Rahman, 1825 Eye Street NW, Washington, DC 20006, (202) 420-2200, [brett.snyder@blankrome.com](mailto:brett.snyder@blankrome.com) or [lamiya.rahman@blankrome.com](mailto:lamiya.rahman@blankrome.com).

Pursuant to Section 157.9 of the Commission's Rules of Practice and Procedure,<sup>3</sup> within 90 days of this Notice the Commission staff will either: Complete its environmental review and place it into the Commission's public record (eLibrary) for this proceeding; or issue a Notice of Schedule for Environmental Review. If a Notice of Schedule for Environmental Review is issued, it will indicate, among other milestones, the anticipated date for the Commission staff's issuance of the final environmental impact statement (FEIS) or environmental assessment (EA) for this proposal. The filing of an EA in the Commission's public record for this proceeding or the issuance of a Notice of Schedule for Environmental Review will serve to notify federal and state agencies of the timing for the completion of all necessary reviews, and the subsequent need to complete all federal authorizations within 90 days of the date of issuance of the Commission staff's FEIS or EA.

### Public Participation

There are two ways to become involved in the Commission's review of this project: You can file comments on the project, and you can file a motion to intervene in the proceeding. There is no fee or cost for filing comments or intervening. The deadline for filing a motion to intervene is 5:00 p.m. Eastern Time on February 18, 2022.

### Comments

Any person wishing to comment on the project may do so. Comments may include statements of support or objections to the project as a whole or specific aspects of the project. The more specific your comments, the more useful they will be. To ensure that your comments are timely and properly recorded, please submit your comments on or before February 18, 2021.

There are three methods you can use to submit your comments to the Commission. In all instances, please reference the Project docket number CP22-41-000 in your submission.

(1) You may file your comments electronically by using the eComment feature, which is located on the Commission's website at [www.ferc.gov](http://www.ferc.gov)

under the link to Documents and Filings. Using eComment is an easy method for interested persons to submit brief, text-only comments on a project;

(2) You may file your comments electronically by using the eFiling feature, which is located on the Commission's website ([www.ferc.gov](http://www.ferc.gov)) under the link to Documents and Filings. With eFiling, you can provide comments in a variety of formats by attaching them as a file with your submission. New eFiling users must first create an account by clicking on "eRegister." You will be asked to select the type of filing you are making; first select "General" and then select "Comment on a Filing"; or

(3) You can file a paper copy of your comments by mailing them to the following address below. Your written comments must reference the Project docket number (CP22-41-000).

*To mail via USPS, use the following address:* Kimberly D. Bose, Secretary, Federal Energy Regulatory Commission, 888 First Street NE, Washington, DC 20426.

*To mail via any other courier, use the following address:* Kimberly D. Bose, Secretary, Federal Energy Regulatory Commission, 12225 Wilkins Avenue, Rockville, Maryland 20852.

The Commission encourages electronic filing of comments (options 1 and 2 above) and has eFiling staff available to assist you at (202) 502-8258 or [FercOnlineSupport@ferc.gov](mailto:FercOnlineSupport@ferc.gov).

Persons who comment on the environmental review of this project will be placed on the Commission's environmental mailing list, and will receive notification when the environmental documents (EA or EIS) are issued for this project and will be notified of meetings associated with the Commission's environmental review process.

The Commission considers all comments received about the project in determining the appropriate action to be taken. However, the filing of a comment alone will not serve to make the filer a party to the proceeding. To become a party, you must intervene in the proceeding. For instructions on how to intervene, see below.

### Interventions

Any person, which includes individuals, organizations, businesses, municipalities, and other entities,<sup>4</sup> has the option to file a motion to intervene in this proceeding. Only intervenors have the right to request rehearing of Commission orders issued in this proceeding and to subsequently

<sup>1</sup> Cameron LNG, LLC, 155 FERC ¶ 61,141 (2016).

<sup>2</sup> The 2016 Order authorized Cameron LNG to construct and operate two additional liquefaction trains (Trains 4 and 5) and one additional storage tank that would increase the Cameron LNG Terminal's maximum natural gas liquefaction capacity by 9.97 million tonnes per annum (MTPA) referred to as the Expansion Project.

<sup>3</sup> 18 CFR (Code of Federal Regulations) § 157.9.

<sup>4</sup> 18 CFR 385.102(d).

challenge the Commission's orders in the U.S. Circuit Courts of Appeal.

To intervene, you must submit a motion to intervene to the Commission in accordance with Rule 214 of the Commission's Rules of Practice and Procedure<sup>5</sup> and the regulations under the NGA<sup>6</sup> by the intervention deadline for the project, which is February 18, 2022. As described further in Rule 214, your motion to intervene must state, to the extent known, your position regarding the proceeding, as well as your interest in the proceeding. [For an individual, this could include your status as a landowner, ratepayer, resident of an impacted community, or recreationist. You do not need to have property directly impacted by the project in order to intervene.] For more information about motions to intervene, refer to the FERC website at <https://www.ferc.gov/resources/guides/how-to-intervene.asp>.

There are two ways to submit your motion to intervene. In both instances, please reference the Project docket number CP22-41-000 in your submission.

(1) You may file your motion to intervene by using the Commission's eFiling feature, which is located on the Commission's website ([www.ferc.gov](http://www.ferc.gov)) under the link to Documents and Filings. New eFiling users must first create an account by clicking on "eRegister." You will be asked to select the type of filing you are making; first select "General" and then select "Intervention." The eFiling feature includes a document-less intervention option; for more information, visit <https://www.ferc.gov/docs-filing/efiling/document-less-intervention.pdf>; or

(2) You can file a paper copy of your motion to intervene, along with three copies, by mailing the documents to the address below. Your motion to intervene must reference the Project docket number CP22-41-000.

To mail via USPS, use the following address: Kimberly D. Bose, Secretary, Federal Energy Regulatory Commission, 888 First Street NE, Washington, DC 20426.

To mail via any other courier, use the following address: Kimberly D. Bose, Secretary, Federal Energy Regulatory Commission, 12225 Wilkins Avenue, Rockville, Maryland 20852.

The Commission encourages electronic filing of motions to intervene (option 1 above) and has eFiling staff available to assist you at (202) 502-8258 or [FercOnlineSupport@ferc.gov](mailto:FercOnlineSupport@ferc.gov).

Motions to intervene must be served on the applicant either by mail or email at: Cameron LNG, LLC, 2925 Briarpark Drive, Suite 1000, Houston, TX 77042, or at [bwoodward@cameronlng.com](mailto:bwoodward@cameronlng.com). Any subsequent submissions by an intervenor must be served on the applicant and all other parties to the proceeding. Contact information for parties can be downloaded from the service list at the eService link on FERC Online. Service can be via email with a link to the document.

All timely, unopposed<sup>7</sup> motions to intervene are automatically granted by operation of Rule 214(c)(1).<sup>8</sup> Motions to intervene that are filed after the intervention deadline are untimely and may be denied. Any late-filed motion to intervene must show good cause for being late and must explain why the time limitation should be waived and provide justification by reference to factors set forth in Rule 214(d) of the Commission's Rules and Regulations.<sup>9</sup> A person obtaining party status will be placed on the service list maintained by the Secretary of the Commission and will receive copies (paper or electronic) of all documents filed by the applicant and by all other parties.

#### Tracking the Proceeding

Throughout the proceeding, additional information about the project will be available from the Commission's Office of External Affairs, at (866) 208-FERC, or on the FERC website at [www.ferc.gov](http://www.ferc.gov) using the "eLibrary" link as described above. The eLibrary link also provides access to the texts of all formal documents issued by the Commission, such as orders, notices, and rulemakings.

In addition, the Commission offers a free service called eSubscription which allows you to keep track of all formal issuances and submittals in specific dockets. This can reduce the amount of time you spend researching proceedings by automatically providing you with notification of these filings, document summaries, and direct links to the documents. For more information and to register, go to [www.ferc.gov/docs-filing/esubscription.asp](http://www.ferc.gov/docs-filing/esubscription.asp).

Intervention Deadline: 5:00 p.m. Eastern Time on February 18, 2022.

Dated: January 28, 2022.

**Kimberly D. Bose,**

Secretary.

[FR Doc. 2022-02214 Filed 2-2-22; 8:45 am]

**BILLING CODE 6717-01-P**

<sup>7</sup> The applicant has 15 days from the submittal of a motion to intervene to file a written objection to the intervention.

<sup>8</sup> 18 CFR 385.214(c)(1).

<sup>9</sup> 18 CFR 385.214(b)(3) and (d).

## DEPARTMENT OF ENERGY

### Federal Energy Regulatory Commission

[Docket No. CP21-463-000]

#### Texas Eastern Transmission, LP Notice of Schedule for the Preparation of an Environmental Assessment for the Holbrook Compressor Units Replacement Project

On June 17, 2021, Texas Eastern Transmission, LP (Texas Eastern) filed an application in Docket No. CP21-463-000 requesting authorization and a Certificate of Public Convenience and Necessity pursuant to Sections 7(b) and 7(c) of the Natural Gas Act to abandon certain natural gas facilities, and construct, operate, and maintain certain natural gas facilities. The proposed project is known as the Holbrook Compressor Station Replacement Project (Project). Texas Eastern is requesting authorization to abandon twelve existing reciprocating compressor units installed in the 1950s at its Holbrook Compressor Station in Greene County, Pennsylvania, and replace them with two new, more efficient gas turbines.

On July 2, 2021, the Federal Energy Regulatory Commission (FERC or Commission) issued its Notice of Application for the Project. Among other things, that notice alerted other agencies issuing federal authorizations of the requirement to complete all necessary reviews and to reach a final decision on the request for a federal authorization within 90 days of the date of issuance of the Commission staff's environmental document for the Project. This notice identifies the Commission staff's intention to prepare an environmental assessment (EA) for the Project and the planned schedule for completion of the environmental review.<sup>1</sup>

#### Schedule for Environmental Review

Issuance of EA—May 12, 2022  
90-day Federal Authorization Decision  
Deadline<sup>2</sup>—August 10, 2022

If a schedule change becomes necessary for the EA, an additional notice will be provided so that the relevant agencies are kept informed of the Project's progress.

<sup>1</sup> 40 CFR 1501.10 (2020)

<sup>2</sup> The Commission's deadline applies to the decisions of other federal agencies, and state agencies acting under federally delegated authority, that are responsible for federal authorizations, permits, and other approvals necessary for proposed projects under the Natural Gas Act. Per 18 CFR 157.22(a), the Commission's deadline for other agency's decisions applies unless a schedule is otherwise established by federal law.

<sup>5</sup> 18 CFR 385.214.

<sup>6</sup> 18 CFR 157.10.

### Project Description

Texas Eastern proposes to abandon-in-place eight existing 1,350-horsepower natural gas engine-compressor units and four 2,000-horsepower compressor units that were installed in the 1950s. To replace them, Texas Eastern proposes to install two new 9,676-horsepower Solar Taurus 70 natural gas-fired compressor units, software controls, and associated auxiliary piping and equipment within a new 8,500-square-foot building.

### Background

On October 1, 2021, the Commission issued a *Notice of Scoping Period Requesting Comments on Environmental Issues for the Proposed Holbrook Compressor Station Units Replacement Project* (Notice of Scoping). The Notice of Scoping was sent to federal, state, and local government agencies; elected officials; affected landowners; environmental and public interest groups; potentially interested Indian tribes and regional organizations; commentors and other interested parties; and local libraries and newspapers. In response to the Notice of Scoping, the Commission received comments from the U.S. Environmental Protection Agency, Region 3, concerning the Project purpose and need, alternatives, climate change, environmental justice, and cumulative impacts. All substantive comments will be addressed in the EA.

### Additional Information

In order to receive notification of the issuance of the EA and to keep track of all formal issuances and submittals in specific dockets, the Commission offers a free service called eSubscription. This can reduce the amount of time you spend researching proceedings by automatically providing you with notification of these filings, document summaries, and direct links to the documents. Go to <https://www.ferc.gov/ferc-online/overview> to register for eSubscription.

Additional information about the Project is available from the Commission's Office of External Affairs at (866) 208-FERC or on the FERC website ([www.ferc.gov](http://www.ferc.gov)). Using the "eLibrary" link, select "General Search" from the eLibrary menu, enter the selected date range and "Docket Number" (i.e., CP21-463), and follow the instructions. For assistance with access to eLibrary, the helpline can be reached at (866) 208-3676,

TTY (202) 502-8659, or at [FERCOnlineSupport@ferc.gov](mailto:FERCOnlineSupport@ferc.gov). The eLibrary link on the FERC website also provides access to the texts of formal

documents issued by the Commission, such as orders, notices, and rule makings.

Dated: January 28, 2022.

**Kimberly D. Bose,**

Secretary.

[FR Doc. 2022-02219 Filed 2-2-22; 8:45 am]

**BILLING CODE 6717-01-P**

## DEPARTMENT OF ENERGY

### Federal Energy Regulatory Commission

#### Combined Notice of Filings

Take notice that the Commission has received the following Natural Gas Pipeline Rate and Refund Report filings:

#### Filings Instituting Proceedings

*Docket Numbers:* RP22-499-000.  
*Applicants:* Big Sandy Pipeline, LLC.  
*Description:* Compliance filing; Big Sandy Fuel Filing effective 3/1/2022 to be effective N/A.

*Filed Date:* 1/27/22.

*Accession Number:* 20220127-5206.

*Comment Date:* 5 p.m. ET 2/8/22.

*Docket Numbers:* RP22-500-000.

*Applicants:* Gazprom Marketing & Trading USA, Inc., Gazprom Mex (UK) 2 Limited.

*Description:* Joint Petition for Temporary Waiver of Capacity Release Regulations, et al. of Gazprom Marketing & Trading USA, Inc., et al.

*Filed Date:* 1/27/22.

*Accession Number:* 20220127-5229.

*Comment Date:* 5 p.m. ET 2/8/22.

*Docket Numbers:* RP22-501-000.

*Applicants:* ANR Pipeline Company.  
*Description:* § 4(d) Rate Filing: ANR Section 4 Rate Case (1 of 4) to be effective 3/1/2022.

*Filed Date:* 1/28/22.

*Accession Number:* 20220128-5036.

*Comment Date:* 5 p.m. ET 2/9/22.

*Docket Numbers:* RP22-502-000.

*Applicants:* Eastern Gas Transmission and Storage, Inc.

*Description:* § 4(d) Rate Filing: EGTS—January 28, 2022 Negotiated Rate Agreements to be effective 3/1/2022.

*Filed Date:* 1/28/22.

*Accession Number:* 20220128-5068.

*Comment Date:* 5 p.m. ET 2/9/22.

*Docket Numbers:* RP22-503-000.

*Applicants:* Ruby Pipeline, L.L.C.  
*Description:* § 4(d) Rate Filing: Fuel LU and EPC Update Filing to be effective 3/1/2022.

*Filed Date:* 1/28/22.

*Accession Number:* 20220128-5084.

*Comment Date:* 5 p.m. ET 2/9/22.

*Docket Numbers:* RP22-504-000.

*Applicants:* Sierrita Gas Pipeline LLC.  
*Description:* § 4(d) Rate Filing: Fuel and L&U Update Filing to be effective 3/1/2022.

*Filed Date:* 1/28/22.

*Accession Number:* 20220128-5090.

*Comment Date:* 5 p.m. ET 2/9/22.

*Docket Numbers:* RP22-505-000.

*Applicants:* Wyoming Interstate Company, L.L.C.

*Description:* § 4(d) Rate Filing: Fuel and Lost and Unaccounted for to be effective 3/1/2022.

*Filed Date:* 1/28/22.

*Accession Number:* 20220128-5177.

*Comment Date:* 5 p.m. ET 2/9/22.

*Docket Numbers:* RP22-506-000.

*Applicants:* Gulf South Pipeline Company, LLC.

*Description:* § 4(d) Rate Filing: Cap Rel Neg Rate Agmts (Atlanta Gas 8438 releases eff 2-1-2022) to be effective 2/1/2022.

*Filed Date:* 1/28/22.

*Accession Number:* 20220128-5198.

*Comment Date:* 5 p.m. ET 2/9/22.

Any person desiring to intervene or protest in any of the above proceedings must file in accordance with Rules 211 and 214 of the Commission's Regulations (18 CFR 385.211 and 385.214) on or before 5:00 p.m. Eastern time on the specified comment date. Protests may be considered, but intervention is necessary to become a party to the proceeding.

#### Filings in Existing Proceedings

*Docket Numbers:* RP11-1711-000.  
*Applicants:* Texas Gas Transmission, LLC.

*Description:* Refund Report: 2021 Cash Out Filing to be effective N/A.

*Filed Date:* 1/28/22.

*Accession Number:* 20220128-5095.

*Comment Date:* 5 p.m. ET 2/9/22.

*Docket Numbers:* RP20-614-006.

*Applicants:* Transcontinental Gas Pipe Line Company, LLC.

*Description:* Refund Report: Cash Out 2nd Supplemental Refund Report Docket Nos. RP20-614 & RP20-618 to be effective N/A.

*Filed Date:* 1/28/22.

*Accession Number:* 20220128-5218.

*Comment Date:* 5 p.m. ET 2/9/22.

*Docket Numbers:* RP22-501-000.

*Applicants:* ANR Pipeline Company.  
*Description:* Report Filing: ANR Section 4 Rate Case (2 of 4) to be effective N/A.

*Filed Date:* 1/28/22.

*Accession Number:* 20220128-5044.

*Comment Date:* 5 p.m. ET 2/9/22.

*Docket Numbers:* RP22-501-000.

*Applicants:* ANR Pipeline Company.  
*Description:* Report Filing: ANR Section 4 Rate Case (3 of 4) to be effective N/A.

*Filed Date:* 1/28/22.

*Accession Number:* 20220128–5051.

*Comment Date:* 5 p.m. ET 2/9/22.

*Docket Numbers:* RP22–501–000.

*Applicants:* ANR Pipeline Company.

*Description:* Report Filing: ANR

Section 4 Rate Case (4 of 4) to be effective N/A.

*Filed Date:* 1/28/22.

*Accession Number:* 20220128–5059.

*Comment Date:* 5 p.m. ET 2/9/22.

Any person desiring to protest in any of the above proceedings must file in accordance with Rule 211 of the Commission's Regulations (18 CFR 385.211) on or before 5:00 p.m. Eastern time on the specified comment date.

The filings are accessible in the Commission's eLibrary system (<https://elibrary.ferc.gov/idmws/search/fercgensearch.asp>) by querying the docket number.

eFiling is encouraged. More detailed information relating to filing requirements, interventions, protests, service, and qualifying facilities filings can be found at: <http://www.ferc.gov/docs-filing/efiling/filing-req.pdf>. For other information, call (866) 208–3676 (toll free). For TTY, call (202) 502–8659.

Dated: January 28, 2022.

**Kimberly D. Bose,**

*Secretary.*

[FR Doc. 2022–02215 Filed 2–2–22; 8:45 am]

**BILLING CODE 6717–01–P**

## DEPARTMENT OF ENERGY

### Federal Energy Regulatory Commission

[Project No. 2077–119]

#### Great River Hydro, LLC; Notice of Availability of Environmental Assessment

In accordance with the National Environmental Policy Act of 1969 and the Federal Energy Regulatory Commission's (Commission or FERC) regulations, 18 Code of Federal Regulations (CFR) Part 380, Commission staff reviewed Great River Hydro, LLC's application for an amendment to the license of the Fifteen Mile Falls Hydroelectric Project No. 2077 and have prepared an Environmental Assessment (EA) for the proposed amendment. The licensee proposes to construct and operate an additional 4.7-megawatt unit (Moore Unit 5) at the project's Moore Development. The Fifteen Mile Falls project consists of three developments located on the Connecticut River, in Grafton and Coos counties, New Hampshire, and Caledonia and Essex counties, Vermont.

The EA contains Commission staff's analysis of the potential environmental effects of the proposed amendment to the license, and concludes that the proposed amendment, with appropriate environmental protective measures, would not constitute a major federal action that would significantly affect the quality of the human environment.

A copy of the EA may be viewed on the Commission's website at <http://www.ferc.gov> using the "elibrary" link. Enter the docket number (P–2077) in the docket number field to access the document. At this time, the Commission has suspended access to the Commission's Public Reference Room, due to the proclamation declaring a National Emergency concerning the Novel Coronavirus Disease (COVID–19), issued by the President on March 13, 2020. For assistance, contact FERC Online Support at [FERCOnlineSupport@ferc.gov](mailto:FERCOnlineSupport@ferc.gov) or toll-free at 1–866–208–3372, or for TTY, (202) 502–8659.

For further information, contact Marybeth Gay at 202–502–6125 or [Marybeth.Gay@ferc.gov](mailto:Marybeth.Gay@ferc.gov).

Dated: January 28, 2022.

**Kimberly D. Bose,**

*Secretary.*

[FR Doc. 2022–02217 Filed 2–2–22; 8:45 am]

**BILLING CODE 6717–01–P**

## DEPARTMENT OF ENERGY

### Federal Energy Regulatory Commission

#### Combined Notice of Filings #1

Take notice that the Commission received the following electric rate filings:

*Docket Numbers:* ER19–1637–001.

*Applicants:* Southwest Power Pool, Inc.

*Description:* Compliance filing: Notice of Effective Date—Revisions to Allow DVERs to Utilize Control Status 3 to be effective N/A.

*Filed Date:* 1/28/22.

*Accession Number:* 20220128–5232.

*Comment Date:* 5 p.m. ET 2/18/22.

*Docket Numbers:* ER22–740–000.

*Applicants:* GridLiance West LLC.

*Description:* Annual Informational Filing of 2022 Projected Net Revenue Requirement and 2020 True-Up Adjustment of GridLiance West LLC.

*Filed Date:* 12/28/21.

*Accession Number:* 20211228–5243.

*Comment Date:* 5 p.m. ET 2/7/22.

*Docket Numbers:* ER22–784–001.

*Applicants:* CPV Maple Hill Solar, LLC.

*Description:* Tariff Amendment: Amendment to Market-Based Rate Application to be effective 3/9/2022.

*Filed Date:* 1/28/22.

*Accession Number:* 20220128–5146.

*Comment Date:* 5 p.m. ET 2/18/22.

*Docket Numbers:* ER22–910–000.

*Applicants:* Rockland Electric Company, PJM Interconnection, L.L.C.

*Description:* § 205(d) Rate Filing: Rockland Electric Company submits tariff filing per 35.13(a)(1): RECO revisions to Schedules 1A, 7, 8 & Att. H–12 to update ATRR & rates to be effective 3/30/2022.

*Filed Date:* 1/28/22.

*Accession Number:* 20220128–5109.

*Comment Date:* 5 p.m. ET 2/18/22.

*Docket Numbers:* ER22–911–000.

*Applicants:* NSTAR Electric Company.

*Description:* Tariff Amendment: Cancellation—Preliminary Engineering and Design Agreement with Ocean State Power to be effective 1/28/2021.

*Filed Date:* 1/28/22.

*Accession Number:* 20220128–5141.

*Comment Date:* 5 p.m. ET 2/18/22.

*Docket Numbers:* ER22–911–001.

*Applicants:* NSTAR Electric Company.

*Description:* Tariff Amendment: Amended Cancellation—Preliminary Engineering Design Agreement Ocean State Power to be effective 1/28/2022.

*Filed Date:* 1/28/22.

*Accession Number:* 20220128–5274.

*Comment Date:* 5 p.m. ET 2/18/22.

*Docket Numbers:* ER22–912–000.

*Applicants:* The Connecticut Light and Power Company.

*Description:* Tariff Amendment: Cancellation—Preliminary Engineering Design Agreement—University of Connecticut to be effective 1/28/2022.

*Filed Date:* 1/28/22.

*Accession Number:* 20220128–5164.

*Comment Date:* 5 p.m. ET 2/18/22.

*Docket Numbers:* ER22–913–000.

*Applicants:* Mid-Atlantic Interstate Transmission, LLC, PJM Interconnection, L.L.C.

*Description:* § 205(d) Rate Filing: Mid-Atlantic Interstate Transmission, LLC submits tariff filing per 35.13(a)(2)(iii): MAIT submits five ECSAs, SA Nos. 6285–6289 to be effective 3/30/2022.

*Filed Date:* 1/28/22.

*Accession Number:* 20220128–5168.

*Comment Date:* 5 p.m. ET 2/18/22.

*Docket Numbers:* ER22–914–000.

*Applicants:* Southwest Power Pool, Inc.

*Description:* § 205(d) Rate Filing: Revisions to Attachment AE to Add Uncertainty Reserve to be effective 12/31/9998.

*Filed Date:* 1/28/22.  
*Accession Number:* 20220128–5183  
*Comment Date:* 5 p.m. ET 2/18/22.  
*Docket Numbers:* ER22–915–000.  
*Applicants:* Energia Sierra Juarez 2 U.S., LLC.  
*Description:* Tariff Amendment: Energia Sierra Juarez 2 U.S.—Notice of Cancellation of Market Based Rate Tariff to be effective 1/29/2022.  
*Filed Date:* 1/28/22.  
*Accession Number:* 20220128–5245.  
*Comment Date:* 5 p.m. ET 2/18/22.  
*Docket Numbers:* ER22–916–000.  
*Applicants:* Midcontinent Independent System Operator, Inc.  
*Description:* § 205(d) Rate Filing: 2022–01–28 SA 3770 NIPSCO-Indiana Crossroads Wind Farm GIA (J1069) to be effective 3/30/2022.  
*Filed Date:* 1/28/22.  
*Accession Number:* 20220128–5256.  
*Comment Date:* 5 p.m. ET 2/18/22.  
*Docket Numbers:* ER22–917–000.  
*Applicants:* Tri-State Generation and Transmission Association, Inc.  
*Description:* Tariff Amendment: Notice of Cancellation of Rate Schedule FERC No. 180 to be effective 3/20/2022.  
*Filed Date:* 1/28/22.  
*Accession Number:* 20220128–5271.  
*Comment Date:* 5 p.m. ET 2/18/22.  
*Docket Numbers:* ER22–918–000.  
*Applicants:* New York State Electric & Gas Corporation, New York Independent System Operator, Inc.  
*Description:* § 205(d) Rate Filing: New York State Electric & Gas Corporation submits tariff filing per 35.13(a)(2)(iii): 205: E&P Agreement between NYSEG and Trelina Solar Energy Center (SA 2684) to be effective 10/8/2021.  
*Filed Date:* 1/28/22.  
*Accession Number:* 20220128–5280.  
*Comment Date:* 5 p.m. ET 2/18/22.  
*Docket Numbers:* ER22–919–000.  
*Applicants:* PJM Interconnection, L.L.C.  
*Description:* § 205(d) Rate Filing: Original WMPA, Service Agreement No. 6328; Queue No. AG2–399 to be effective 1/19/2022.  
*Filed Date:* 1/28/22.  
*Accession Number:* 20220128–5309.  
*Comment Date:* 5 p.m. ET 2/18/22.  
*Docket Numbers:* ER22–920–000.  
*Applicants:* Tri-State Generation and Transmission Association, Inc.  
*Description:* § 205(d) Rate Filing: Service Agreement No. 903 to be effective 2/25/2020.  
*Filed Date:* 1/28/22.  
*Accession Number:* 20220128–5340.  
*Comment Date:* 5 p.m. ET 2/18/22.  
*Docket Numbers:* ER22–921–000.  
*Applicants:* Public Service Company of Colorado.

*Description:* § 205(d) Rate Filing: 2022–01–28 PSC–CORE–SISA–670–0.0.0 to be effective 1/29/2022.  
*Filed Date:* 1/28/22.  
*Accession Number:* 20220128–5344.  
*Comment Date:* 5 p.m. ET 2/18/22.  
*Docket Numbers:* ER22–922–000.  
*Applicants:* United Energy Partners, LLC.  
*Description:* Baseline eTariff Filing: Market-Based Rate Tariff Application to be effective 1/29/2022.  
*Filed Date:* 1/28/22.  
*Accession Number:* 20220128–5355.  
*Comment Date:* 5 p.m. ET 2/18/22.  
*Docket Numbers:* ER22–923–000.  
*Applicants:* Basin Electric Power Cooperative.  
*Description:* Tariff Amendment: Basin Electric Notice of Cancellation of Service Agreements to be effective 3/30/2022.  
*Filed Date:* 1/28/22.  
*Accession Number:* 20220128–5362.  
*Comment Date:* 5 p.m. ET 2/18/22.  
 The filings are accessible in the Commission’s eLibrary system (<https://elibrary.ferc.gov/idmws/search/fercgensearch.asp>) by querying the docket number.  
 Any person desiring to intervene or protest in any of the above proceedings must file in accordance with Rules 211 and 214 of the Commission’s Regulations (18 CFR 385.211 and 385.214) on or before 5:00 p.m. Eastern time on the specified comment date. Protests may be considered, but intervention is necessary to become a party to the proceeding.  
 eFiling is encouraged. More detailed information relating to filing requirements, interventions, protests, service, and qualifying facilities filings can be found at: <http://www.ferc.gov/docs-filing/efiling/filing-req.pdf>. For other information, call (866) 208–3676 (toll free). For TTY, call (202) 502–8659.  
 Dated: January 28, 2022.  
**Kimberly D. Bose,**  
*Secretary.*  
 [FR Doc. 2022–02220 Filed 2–2–22; 8:45 am]  
**BILLING CODE 6717–01–P**

---

**ENVIRONMENTAL PROTECTION AGENCY**  
**[EPA–HQ–OPP–2017–0751; FRL–9436–01–OCSPF]**  
**Pesticide Registration Review; Interim Decision; Notice of Availability; Correction**  
**AGENCY:** Environmental Protection Agency (EPA).  
**ACTION:** Notice; correction.

**SUMMARY:** EPA issued a notice in the **Federal Register** of July 30, 2021, concerning the availability of EPA’s interim registration review decisions and case closures for several pesticides, including citric acid. This document corrects an incorrect docket number and case number in the notice for citric acid.

**FOR FURTHER INFORMATION CONTACT:** SanYvette Williams, Antimicrobials Division (7510P), Office of Pesticide Programs, Environmental Protection Agency, 1200 Pennsylvania Ave. NW, Washington, DC 20460–0001; telephone number: (202) 566–0912; email address: [williams.sanyvette@epa.gov](mailto:williams.sanyvette@epa.gov).

**SUPPLEMENTARY INFORMATION:**

**I. General Information**

*A. Does this action apply to me?*

The Agency included in the July 30, 2021 notice a list of those who may be potentially affected by this action.

*B. How can I get copies of this document and other related information?*

The docket for this action, identified by docket identification (ID) number EPA–HQ–OPP–2017–0751, is available at <http://www.regulations.gov> or at the Office of Pesticide Programs Regulatory Public Docket (OPP Docket) in the Environmental Protection Agency Docket Center (EPA/DC), West William Jefferson Clinton Bldg., Rm. 3334, 1301 Constitution Ave. NW, Washington, DC 20460–0001. The Public Reading Room is open from 8:30 a.m. to 4:30 p.m., Monday through Friday, excluding legal holidays. The telephone number for the Public Reading Room is (202) 566–1744, and the telephone number for the OPP Docket is (703) 305–5805. Due to the public health concerns related to COVID–19, the EPA Docket Center (EPA/DC) and Reading Room are closed to visitors with limited exceptions. The staff continues to provide remote customer service via email, phone, and webform. For the latest status information on EPA/DC services and docket access, visit <http://www.epa.gov/dockets>.

**II. What does this correction do?**

FR Doc. 2021–16318 published in the **Federal Register** of July 30, 2021 (86 FR 41032) (FRL–8677–01–OCSPF) is corrected as follows:

1. On page 41032, second column, under the heading, “Table 1—Registration Review Interim Decisions Being Issued”, Docket ID No., line 4, correct “EPA–HQ–OPP–2008–0855” to read “EPA–HQ–OPP–2020–0558”.

2. The first column under the same heading, under “Registration Review case name and No.”, line 4, should

correct “Citric acid, Case Number 4024” to read “Citric acid, Case Number 4024–2”.

*Authority:* 7 U.S.C. 136 *et seq.*

Dated: January 28, 2022.

**Anita Pease,**

*Director, Antimicrobials Division, Office of Pesticide Programs.*

[FR Doc. 2022–02208 Filed 2–2–22; 8:45 am]

BILLING CODE 6560–50–P

## ENVIRONMENTAL PROTECTION AGENCY

[EPA–HQ–OPP–2017–0750; FRL–9451–01–OCSPP]

### Pesticide Registration Review; Proposed Interim Decisions for Several Pesticides; Notice of Availability

**AGENCY:** Environmental Protection Agency (EPA).

**ACTION:** Notice.

**SUMMARY:** This notice announces the availability of EPA’s proposed interim registration review decisions and opens a 60-day public comment period on the proposed interim decisions for the following pesticides: Dimethoxane; ferbam; iprodione; laminarin; linalool; thiram; and ziram.

**DATES:** Comments must be received on or before April 4, 2022.

**ADDRESSES:** Submit your comments, identified by the docket identification (ID) number for the specific pesticide of interest provided in the Table in Unit IV., using the Federal eRulemaking Portal at <http://www.regulations.gov>. Follow the online instructions for submitting comments. Do not submit electronically any information you consider to be Confidential Business Information (CBI) or other information whose disclosure is restricted by statute. Additional instructions on commenting or visiting the docket, along with more information about dockets generally, is available at <http://www.epa.gov/dockets>.

Due to the public health concerns related to COVID–19, the EPA/DC and Reading Room is closed to visitors with limited exceptions. The staff continues to provide remote customer service via email, phone, and webform. For the latest status information on the EPA/DC and docket access, visit <https://www.epa.gov/dockets>.

**FOR FURTHER INFORMATION CONTACT:**

*For pesticide specific information, contact:* The Chemical Review Manager for the pesticide of interest identified in the Table in Unit IV.

*For general information on the registration review program, contact:* Melanie Biscoe, Pesticide Re-Evaluation Division (7508P), Office of Pesticide Programs, Environmental Protection Agency, 1200 Pennsylvania Ave. NW, Washington, DC 20460–0001; email address: [biscoe.melanie@epa.gov](mailto:biscoe.melanie@epa.gov).

#### SUPPLEMENTARY INFORMATION:

### I. General Information

#### A. Does this action apply to me?

This action is directed to the public in general and may be of interest to a wide range of stakeholders including environmental, human health, farm worker, and agricultural advocates; the chemical industry; pesticide users; and members of the public interested in the sale, distribution, or use of pesticides. Since others also may be interested, the Agency has not attempted to describe all the specific entities that may be affected by this action. If you have any questions regarding the applicability of this action to a particular entity, consult the Chemical Review Manager for the pesticide of interest identified in the Table 1 in Unit IV.

#### B. What should I consider as I prepare my comments for EPA?

1. *Submitting CBI.* Do not submit this information to EPA through [regulations.gov](http://www.regulations.gov) or email. Clearly mark the part or all of the information that you claim to be CBI. For CBI information on a disk or CD–ROM that you mail to EPA, mark the outside of the disk or CD–ROM as CBI and then identify electronically within the disk or CD–ROM the specific information that is claimed as CBI. In addition to one complete version of the comment that includes information claimed as CBI, a copy of the comment that does not contain the information claimed as CBI must be submitted for inclusion in the public docket. Information so marked will not be disclosed except in accordance with procedures set forth in 40 CFR part 2.

2. *Tips for preparing your comments.* When preparing and submitting your comments, see the commenting tips at: <https://www.epa.gov/dockets/commenting-epa-dockets>.

3. *Environmental justice.* EPA seeks to achieve environmental justice, the fair treatment and meaningful involvement of any group, including minority and/or low-income populations, in the development, implementation, and enforcement of environmental laws, regulations, and policies. To help address potential environmental justice issues, the Agency seeks information on

any groups or segments of the population who, as a result of their location, cultural practices, or other factors, may have atypical or disproportionately high and adverse human health impacts or environmental effects from exposure to the pesticides discussed in this document, compared to the general population.

### II. Background

Registration review is EPA’s periodic review of pesticide registrations to ensure that each pesticide continues to satisfy the statutory standard for registration, that is, the pesticide can perform its intended function without unreasonable adverse effects on human health or the environment. As part of the registration review process, the Agency has completed proposed interim decisions for all pesticides listed in the Table 1 in Unit IV. Through this program, EPA is ensuring that each pesticide’s registration is based on current scientific and other knowledge, including its effects on human health and the environment.

### III. Authority

EPA is conducting its registration review of the chemicals listed in the Table 1 in Unit IV pursuant to section 3(g) of the Federal Insecticide, Fungicide, and Rodenticide Act (FIFRA) and the Procedural Regulations for Registration Review at 40 CFR part 155, subpart C. Section 3(g) of FIFRA provides, among other things, that the registrations of pesticides are to be reviewed every 15 years. Under FIFRA, a pesticide product may be registered or remain registered only if it meets the statutory standard for registration given in FIFRA section 3(c)(5) (7 U.S.C. 136a(c)(5)). When used in accordance with widespread and commonly recognized practice, the pesticide product must perform its intended function without unreasonable adverse effects on the environment; that is, without any unreasonable risk to man or the environment, or a human dietary risk from residues that result from the use of a pesticide in or on food.

### IV. What action is the agency taking?

Pursuant to 40 CFR 155.58, this notice announces the availability of EPA’s proposed interim registration review decisions for the pesticides shown in Table 1 and opens a 60-day public comment period on the proposed interim registration review decisions.



TABLE 1—PROPOSED INTERIM DECISIONS

Registration review case name and No.	Docket ID No.	Chemical review manager and contact information
Dimethoxane, Case Number 3064	EPA-HQ-OPP-2010-0686	Kimberly Wilson, <a href="mailto:wilson.kimberly@epa.gov">wilson.kimberly@epa.gov</a> , (202) 566-0647.
Ferbam, Case Number 8000 .....	EPA-HQ-OPP-2015-0567	Marisa Wright, <a href="mailto:wright.marisa@epa.gov">wright.marisa@epa.gov</a> , (202) 566-2335.
Iprodione, Case Number 2335 .....	EPA-HQ-OPP-2012-0392	Rachel Fletcher, <a href="mailto:fletcher.rachel@epa.gov">fletcher.rachel@epa.gov</a> , (202) 566-2354
Laminarin, Case Number 6309 .....	EPA-HQ-OPP-2021-0445	Jennifer Odom, <a href="mailto:odom.jennifer@epa.gov">odom.jennifer@epa.gov</a> , (202) 566-1536
Linalool, Case Number 6058 .....	EPA-HQ-OPP-2021-0423	Hannah Dean, <a href="mailto:dean.hannah@epa.gov">dean.hannah@epa.gov</a> , (202) 566-1531
Thiram, Case Number 0122 .....	EPA-HQ-OPP-2015-0433	Marisa Wright, <a href="mailto:wright.marisa@epa.gov">wright.marisa@epa.gov</a> , (202) 566-2335
Ziram, Case Number 8001 .....	EPA-HQ-OPP-2015-0568	Marisa Wright, <a href="mailto:wright.marisa@epa.gov">wright.marisa@epa.gov</a> , (202) 566-2335

The registration review docket for a pesticide includes earlier documents related to the registration review case. For example, the review opened with a Preliminary Work Plan, for public comment. A Final Work Plan was placed in the docket following public comment on the Preliminary Work Plan.

The documents in the dockets describe EPA's rationales for conducting additional risk assessments for the registration review of the pesticides included in the tables in Unit IV, as well as the Agency's subsequent risk findings and consideration of possible risk mitigation measures. These proposed interim registration review decisions are supported by the rationales included in those documents. Following public comment, the Agency will issue interim or final registration review decisions for the pesticides listed in Table 1 in Unit IV.

The registration review final rule at 40 CFR 155.58(a) provides for a minimum 60-day public comment period on all proposed interim registration review decisions. This comment period is intended to provide an opportunity for public input and a mechanism for initiating any necessary amendments to the proposed interim decision. All comments should be submitted using the methods in **ADDRESSES** and must be received by EPA on or before the closing date. These comments will become part of the docket for the pesticides included in the Tables in Unit IV. Comments received after the close of the comment period will be marked "late." EPA is not required to consider these late comments.

The Agency will carefully consider all comments received by the closing date and may provide a "Response to Comments Memorandum" in the docket. The interim registration review decision will explain the effect that any comments had on the interim decision

and provide the Agency's response to significant comments.

Background on the registration review program is provided at: <https://www.epa.gov/pesticide-reevaluation>.

*Authority:* 7 U.S.C. 136 *et seq.*

Dated: January 27, 2022.

**Mary Elissa Reaves,**

*Director, Pesticide Re-Evaluation Division, Office of Pesticide Programs.*

[FR Doc. 2022-02197 Filed 2-2-22; 8:45 am]

**BILLING CODE 6560-50-P**

## ENVIRONMENTAL PROTECTION AGENCY

[EPA-HQ-2008-0719; FRL-9526-01-OMS]

### Information Collection Request Submitted to OMB for Review and Approval; Comment Request; National Pollutant Discharge Elimination System Program (Renewal)

**AGENCY:** Environmental Protection Agency (EPA).

**ACTION:** Notice.

**SUMMARY:** The Environmental Protection Agency (EPA) has submitted an information collection request (ICR), "Information Collection Request (ICR) Supporting Statement for The National Pollutant Discharge Elimination System Program (Renewal)" (EPA ICR Number 0229.25, OMB Control Number 2040-0004) to the Office of Management and Budget (OMB) for review and approval in accordance with the Paperwork Reduction Act. This is a proposed extension of the ICR, which is currently approved through March 31, 2022. Public comments were previously requested via the **Federal Register** on July 29, 2021 during a 60-day comment period. This notice allows for an additional 30 days for public comments. A fuller description of the ICR is given below, including its estimated burden

and cost to the public. An agency may not conduct or sponsor and a person is not required to respond to a collection of information unless it displays a currently valid OMB control number.

**DATES:** Additional comments may be submitted on or before March 7, 2022.

**ADDRESSES:** Submit your comments, referencing Docket ID Number EPA-HQ-2008-0719, t online using [www.regulations.gov](http://www.regulations.gov) (our preferred method) or by mail to: EPA Docket Center, Environmental Protection Agency, Mail Code 28221T, 1200 Pennsylvania Ave. NW, Washington, DC 20460.

EPA's policy is that all comments received will be included in the public docket without change including any personal information provided, unless the comment includes profanity, threats, information claimed to be Confidential Business Information (CBI), or other information whose disclosure is restricted by statute.

Submit written comments and recommendations to OMB for the proposed information collection within 30 days of publication of this notice to [www.reginfo.gov/public/do/PRAMain](http://www.reginfo.gov/public/do/PRAMain). Find this particular information collection by selecting "Currently under 30-day Review—Open for Public Comments" or by using the search function.

**FOR FURTHER INFORMATION CONTACT:** Joshua Baehr, National Program Branch, Water Permits Division, OWM Mail Code: 4203M, Environmental Protection Agency, 1201 Constitution Ave. NW, Washington, DC 20460; telephone number: 202-564-2277; email address: [Baehr.Joshua@epa.gov](mailto:Baehr.Joshua@epa.gov).

**SUPPLEMENTARY INFORMATION:** Supporting documents, which explain in detail the information that the EPA will be collecting, are available in the public docket for this ICR. The docket

can be viewed online at [www.regulations.gov](http://www.regulations.gov) or in person at the EPA Docket Center, WJC West, Room 3334, 1301 Constitution Ave. NW, Washington, DC. The telephone number for the Docket Center is 202-566-1744. For additional information about EPA's public docket, visit <http://www.epa.gov/dockets>.

**Abstract:** This Information Collection Request (ICR) renews the National Pollutant Discharge Elimination System (NPDES) Program ICR and consolidates the information collection burden and costs associated with activities previously reported in 18 of the NPDES program or NPDES-related ICRs. It calculates the information collection burden and costs associated with the NPDES program, identifies the types of activities regulated under the NPDES program, describes the roles and responsibilities of state governments and the Agency, and presents the program areas that address the various types of regulated activities. This renewal documents the addition of the burden and costs for the four existing NPDES ICRs listed below. Once this renewal ICR is approved, the following ICRs will be discontinued: Public Notification Requirements for Combined Sewer Overflows (CSOs) in the Great Lakes Basin (OMB control no. 2040-0293, EPA ICR 2562.03, expiration date 04/30/24); Effluent Limitation Guidelines and Standards for the Dental Category (OMB control no. 2040-0287, EPA ICR no. 2514.03, expiration 11/30/23); 2020 NPDES Multi-Sector General Permit (MSGP) for Industrial Stormwater Discharges (OMB control no. 2040-0300, EPA ICR no. 2612.02, expiration 03/31/24); and NPDES Electronic Reporting Rule—Phase 2 Extension (OMB Control No.: 2020-0037, EPA ICR No. 2617.02, expiration 12/31/2023).

The Clean Water Act (CWA) provides that NPDES permits are required for the discharge of pollutants to waters of the United States. The CWA requires EPA to develop and implement the NPDES permit program. CWA section 402(b) allows states to acquire authority to administer the NPDES program, enabling them to issue NPDES permits for discharges within the state. At present, 47 states and the U.S. Virgin Islands are authorized to administer the NPDES permit program. In states that do not have authority for these programs, the Agency administers the program and issues NPDES permits. Because some permit applications are processed by states and some by EPA, this ICR calculates government burden and cost for both authorized states and EPA. See

Appendix F.1 for a copy of the authorizing regulation.

**Form Numbers:** EPA Form 3510-1; EPA Form 3510-2A; EPA Form 3510-2B; EPA Form 3510-2C; EPA Form 3510-2D; EPA Form 3510-2E; EPA Form 3510-2F; EPA Form 3510-2S.

**Respondents/affected entities:** Any point source discharger of pollutants, publicly owned and privately owned treatment works (POTWs and PrOTWs), industrial dischargers to POTWs and PrOTWs, industrial and commercial dischargers to water of the United States, sewage sludge management and disposal operations, large vessels, dischargers of stormwater, construction sites, municipalities, pesticide applicators, local and state governments.

**Respondent's obligation to respond:** Mandatory, sections 301, 302, 304, 306, 307, 308, 316(b), 401, 402, 403, 405, and 510 of the CWA; the 1987 Water Quality Act (WQA) revisions to CWA section 402(p); 40 CFR parts 122, 123, 124, and 125 (and parts 501 and 503 for Biosolids); and the Great Lakes Critical Programs Act (CPA).

**Estimated number of respondents:** 827,180 (total). (Includes 637 States/Tribes/Territories).

**Frequency of response:** Varies depending on the specific response activity and can range from ongoing and monthly to once every five years.

**Total estimated burden:** 31,143,503 hours (per year). Burden is defined at 5 CFR 1320.03(b).

**Total estimated cost:** \$1,732,287,018 (per year), includes \$22,999,181 annualized capital or operation & maintenance costs.

**Changes in the estimates:** The majority of the burden hour increase occurred as a result of an increase in EPA's estimates of permittee respondents, which is largely attributed to improvements in the NPDES Integrated Compliance Information System (ICIS-NPDES) database, implementation of the Electronic Reporting Rule Phase 1, and refined estimates. This ICR eliminates the initial permit application and compliance activities for existing Cooling Water Intake Structure (CWIS) facilities, as these actions have been completed by all existing CWIS facilities. The compliance and administration of small vessels general permit (sVGP) has been removed, which lowered the number of vessel respondents significantly.

**Courtney Kerwin,**

*Director, Regulatory Support Division.*

[FR Doc. 2022-02169 Filed 2-2-22; 8:45 am]

**BILLING CODE 6560-50-P**

## ENVIRONMENTAL PROTECTION AGENCY

[EPA-HQ-OPP-2017-0720; FRL-9450-01-OCSP]

### Pesticide Registration Review; Draft Human Health and/or Ecological Risk Assessments for Several Pesticides; Notice of Availability

**AGENCY:** Environmental Protection Agency (EPA).

**ACTION:** Notice.

**SUMMARY:** This notice announces the availability of EPA's draft human health and/or ecological risk assessments for the registration review of 1,3-Propanediamine, N-(3-aminopropyl)-N-dodecyl- (1,3-PAD).

**DATES:** Comments must be received on or before April 4, 2022.

**ADDRESSES:** Submit your comments, to the docket identification (ID) number for the specific pesticide of interest provided in the Table in Unit IV., using the *Federal eRulemaking Portal* at <http://www.regulations.gov>. Follow the online instructions for submitting comments. Do not submit electronically any information you consider to be Confidential Business Information (CBI) or other information whose disclosure is restricted by statute. Additional instructions on commenting or visiting the docket, along with more information about dockets generally, are available at <http://www.epa.gov/dockets>.

Due to the public health concerns related to COVID-19, the EPA Docket Center (EPA/DC) and Reading Room is open to visitors by appointment only. For the latest status information on EPA/DC services and access, visit <https://www.epa.gov/dockets>.

#### FOR FURTHER INFORMATION CONTACT:

**For pesticide specific information contact:** The Chemical Review Manager for the pesticide of interest identified in Table 1 in Unit IV.

**For general questions on the registration review program, contact:** Melanie Biscoe, Pesticide Re-Evaluation Division (7508P), Office of Pesticide Programs, Environmental Protection Agency, 1200 Pennsylvania Ave. NW, Washington, DC 20460-0001; telephone number: (703) 305-7106; email address: [biscoe.melanie@epa.gov](mailto:biscoe.melanie@epa.gov).

#### SUPPLEMENTARY INFORMATION:

##### I. General Information

###### A. Does this action apply to me?

This action is directed to the public in general and may be of interest to a wide range of stakeholders including environmental, human health, farm worker, and agricultural advocates; the

chemical industry; pesticide users; and members of the public interested in the sale, distribution, or use of pesticides. Since others also may be interested, the Agency has not attempted to describe all the specific entities that may be affected by this action. If you have any questions regarding the applicability of this action to a particular entity, consult the Chemical Review Manager identified in Table 1 in Unit IV.

*B. What should I consider as I prepare my comments for EPA?*

1. *Submitting CBI.* Do not submit this information to EPA through *regulations.gov* or email. Clearly mark the part or all of the information that you claim to be CBI. For CBI information in a disk or CD-ROM that you mail to EPA, mark the outside of the disk or CD-ROM as CBI and then identify electronically within the disk or CD-ROM the specific information that is claimed as CBI. In addition to one complete version of the comment that includes information claimed as CBI, a copy of the comment that does not contain the information claimed as CBI must be submitted for inclusion in the public docket. Information so marked will not be disclosed except in accordance with procedures set forth in 40 CFR part 2.

2. *Tips for preparing your comments.* When preparing and submitting your comments, see the commenting tips at <https://www.epa.gov/dockets/commenting-epa-dockets>.

3. *Environmental justice.* EPA seeks to achieve environmental justice, the fair

treatment and meaningful involvement of any group, including minority and/or low-income populations, in the development, implementation, and enforcement of environmental laws, regulations, and policies. To help address potential environmental justice issues, the Agency seeks information on any groups or segments of the population who, as a result of their location, cultural practices, or other factors, may have atypical or disproportionately high and adverse human health impacts or environmental effects from exposure to the pesticides discussed in this document, compared to the general population.

**II. Background**

Registration review is EPA’s periodic review of pesticide registrations to ensure that each pesticide continues to satisfy the statutory standard for registration, that is, the pesticide can perform its intended function without unreasonable adverse effects on human health or the environment. As part of the registration review process, the Agency has completed comprehensive draft human health and/or ecological risk assessments for all pesticides listed in Table 1 in Unit IV. After reviewing comments received during the public comment period, EPA may issue a revised risk assessment, explain any changes to the draft risk assessment, and respond to comments and may request public input on risk mitigation before completing a proposed registration review decision for the pesticides listed in Table 1 in Unit IV. Through this

program, EPA is ensuring that each pesticide’s registration is based on current scientific and other knowledge, including its effects on human health and the environment.

**III. Authority**

EPA is conducting its registration review of the chemicals listed in Table 1 in Unit IV pursuant to section 3(g) of the Federal Insecticide, Fungicide, and Rodenticide Act (FIFRA) and the Procedural Regulations for Registration Review at 40 CFR part 155, subpart C. Section 3(g) of FIFRA provides, among other things, that the registrations of pesticides are to be reviewed every 15 years. Under FIFRA, a pesticide product may be registered or remain registered only if it meets the statutory standard for registration given in FIFRA section 3(c)(5) (7 U.S.C. 136a(c)(5)). When used in accordance with widespread and commonly recognized practice, the pesticide product must perform its intended function without unreasonable adverse effects on the environment; that is, without any unreasonable risk to man or the environment, or a human dietary risk from residues that result from the use of a pesticide in or on food.

**IV. What action is the Agency taking?**

Pursuant to 40 CFR 155.58, this notice announces the availability of EPA’s human health and/or ecological risk assessments for the pesticides shown in Table 1 and opens a 60-day public comment period on the risk assessments.

TABLE 1—DRAFT RISK ASSESSMENTS BEING MADE AVAILABLE FOR PUBLIC COMMENT

Registration review case name and No.	Docket ID No.	Chemical review manager and contact information
1,3-Propanediamine, N-(3-aminopropyl)-N-dodecyl- (1,3 PAD) Case 5109.	EPA-HQ-OPP-2014-0406 .....	Megan Snyderman, <a href="mailto:snyderman.megan@epa.gov">snyderman.megan@epa.gov</a> , (202) 566-0639.

Pursuant to 40 CFR 155.53(c), EPA is providing an opportunity, through this notice of availability, for interested parties to provide comments and input concerning the Agency’s draft human health and/or ecological risk assessments for the pesticides listed in Table 1 in Unit IV. The Agency will consider all comments received during the public comment period and make changes, as appropriate, to a draft human health and/or ecological risk assessment. EPA may then issue a revised risk assessment, explain any changes to the draft risk assessment, and respond to comments.

*Information submission requirements.* Anyone may submit data or information in response to this document. To be

considered during a pesticide’s registration review, the submitted data or information must meet the following requirements:

- To ensure that EPA will consider data or information submitted, interested persons must submit the data or information during the comment period. The Agency may, at its discretion, consider data or information submitted at a later date.
- The data or information submitted must be presented in a legible and useable form. For example, an English translation must accompany any material that is not in English and a written transcript must accompany any information submitted as an audio-graphic or video-graphic record. Written

material may be submitted in paper or electronic form.

- Submitters must clearly identify the source of any submitted data or information.
- Submitters may request the Agency to reconsider data or information that the Agency rejected in a previous review. However, submitters must explain why they believe the Agency should reconsider the data or information in the pesticide’s registration review.

As provided in 40 CFR 155.58, the registration review docket for each pesticide case will remain publicly accessible through the duration of the registration review process; that is, until all actions required in the final decision

on the registration review case have been completed.

*Authority:* 7 U.S.C. 136 *et seq.*

Dated: January 27, 2022.

**Mary Reaves,**

*Director, Pesticide Re-Evaluation Division,  
Office of Pesticide Programs.*

[FR Doc. 2022-02198 Filed 2-2-22; 8:45 am]

**BILLING CODE 6560-50-P**

## ENVIRONMENTAL PROTECTION AGENCY

[FRL-9535-01-OA]

### Notification of Public Meeting

**AGENCY:** Environmental Protection Agency (EPA).

**ACTION:** Notification of public meeting.

**SUMMARY:** Pursuant to the Federal Advisory Committee Act (FACA), EPA hereby provides notice of a meeting of the Local Government Advisory Committee (LGAC) and the Small Communities Advisory Subcommittee (SCAS) on the date and times described below. This meeting will be open to the public. For information on public attendance and participation, please see the registration information under **SUPPLEMENTARY INFORMATION** section.

**DATES:** The SCAS will meet virtually February 17th, 2022, starting at 11:30 a.m. through 1:00 p.m. Eastern Time. The LGAC will meet virtually February 17th, 2022, starting at 2:00 p.m. through 4:30 p.m. Eastern Time.

**FOR FURTHER INFORMATION CONTACT:** Paige Lieberman, Designated Federal Officer (DFO), at [LGAC@epa.gov](mailto:LGAC@epa.gov) or 202-564-9957.

*Information on Accessibility:* For information on access or services for individuals requiring accessibility accommodations, please contact Paige Lieberman by email at [LGAC@epa.gov](mailto:LGAC@epa.gov). To request accommodation, please do so five (5) business days prior to the meeting, to give EPA as much time as possible to process your request.

### SUPPLEMENTARY INFORMATION:

#### I. General Information

Following the passage of the historic Bipartisan Infrastructure Law (BIL), the U.S. Environmental Protection Agency (EPA) will be making significant investments in the health, equity, and resilience of American communities. With unprecedented funding to support our national infrastructure, EPA will improve people's health and safety, help create good-paying jobs, and increase climate resilience throughout the country.

As EPA works to implement the law, EPA has asked the LGAC for their input on the following:

- How can we ensure that investments in water infrastructure promote sustainable and healthy communities?
- Are there specific recommendations for how EPA can prioritize equity, environmental justice, and the lived experience of those most impacted by water pollution?
- Are there technical resources or assistance that EPA can provide to help local governments upgrade their water and wastewater infrastructure?
- How can EPA make funding more accessible to local governments and more adaptable to the unique needs a community faces—particularly underserved communities?
- Are there specific recommendations for how EPA can include workforce development as part of the implementation of this bill?
- Do you have specific recommendations for how EPA can encourage consideration of climate impacts (e.g., GHG mitigation, adaptation, resilience) in the projects funded?

• Is there specific technical assistance that EPA should offer local governments to ensure they plan for, develop and build infrastructure that supports multiple community goals, including improving environmental and economic outcomes, supporting equity and environmental justice, and increasing communities' abilities to create climate resilience?

• Is there specific input you have for EPA as it develops the Clean School Bus program the in BIL?

During this meeting the LGAC will present, finalize and formally adopt final recommendations for charge questions noted above.

Prior to the LGAC meeting, the SCAS will convene to discuss and provide input from their perspective on the LGAC's draft recommendations for implementation of the Bipartisan Infrastructure Law (BIL).

All interested persons are invited to attend and participate. The SCAS will hear comments from the public from 12:45-1:00 p.m. (EST). The LGAC will hear comments from the public from 3:15-3:30 p.m. (EST). Individuals or organizations wishing to address the Committee or Subcommittee will be allowed a maximum of five (5) minutes to present their point of view. Also, written comments should be submitted electronically to [LGAC@epa.gov](mailto:LGAC@epa.gov) for the LGAC and SCAS. Please contact the DFO at the email listed under **FOR FURTHER INFORMATION CONTACT** to

schedule a time on the agenda by February 14, 2022. Time will be allotted on a first-come first-served basis, and the total period for comments may be extended if the number of requests for appearances requires it.

*Registration:* The meeting will be held virtually through an online audio and video platform. Members of the public who wish to participate should register by contacting the Designated Federal Officer (DFO) at [LGAC@epa.gov](mailto:LGAC@epa.gov) by February 11, 2022. The agenda and other supportive meeting materials will be available online at <https://www.epa.gov/ocir/local-government-advisory-committee-lgac> and can be obtained by written request to the DFO. In the event of cancellation for unforeseen circumstances, please contact the DFO or check the website above for reschedule information.

**Julian Bowles,**

*Director, State and Local Relations, Office of Congressional and Intergovernmental Relations.*

[FR Doc. 2022-02300 Filed 2-2-22; 8:45 am]

**BILLING CODE 6560-50-P**

## FEDERAL MARITIME COMMISSION

[Docket No. 20-10; Petition No. P1-20]

### Investigation Into Conditions Created by Canadian Ballast Water Regulations in the U.S./Canada Great Lakes Trade

**AGENCY:** Federal Maritime Commission.

**ACTION:** Request for comments.

**SUMMARY:** Because of developments within Canada and the United States, the Federal Maritime Commission (Commission) is seeking additional public comments on a petition filed by the Lake Carriers' Association (Petitioner) alleging that conditions created by the Government of Canada (Canada) are unfavorable to shipping in the United States/Canada trade.

**DATES:** Submit comments on or before March 7, 2022.

**ADDRESSES:** You may submit comments, identified by Docket No. 20-10, by the following method:

- *Email:* [secretary@fmc.gov](mailto:secretary@fmc.gov). For comments, include in the subject line: "Docket No. 20-10, Comments on Conditions Created by Canadian Ballast Water Regulations in the U.S./Canada Great Lakes Trade." Comments should be attached to the email as a Microsoft Word or text searchable PDF document.

*Docket:* For access to the docket to read background documents or public comments received, go to the Commission's Electronic Reading Room

at: [www2.fmc.gov/readingroom/proceeding/20-10/](http://www2.fmc.gov/readingroom/proceeding/20-10/).

Unless otherwise directed by the commenter, all comments will be treated as confidential under 46 U.S.C. 42105 and 46 CFR 550.104.

**FOR FURTHER INFORMATION CONTACT:** For questions regarding submitting comments or the treatment of confidential information, contact William Cody, Secretary; Phone: (202) 523-5725; Email: [secretary@fmc.gov](mailto:secretary@fmc.gov).

**SUPPLEMENTARY INFORMATION:**

**I. Introduction**

On March 6, 2020, the Lake Carriers' Association (Petitioner), a trade association made up of U.S. owners and operators of vessels serving the Great Lakes (Lakers), filed a petition alleging that conditions created by Transport Canada, an agency of the Government of Canada, are unfavorable to shipping in the United States/Canada trade, pursuant to Section 19(1)(b) of the Merchant Marine Act, 1920 (Section 19) codified in 46 U.S.C. 42101. Section 19 authorizes the Federal Maritime Commission (Commission) to investigate these conditions and to adopt regulations to "adjust or meet general or special conditions unfavorable to shipping in foreign trade". In this instance, the Petitioner requested that the Commission adopt regulations in order to remedy a condition it alleges will result in irreparable harm to Petitioner's members which are U.S. flag owners and operators of vessels on the Great Lakes.

Specifically, Petitioner argued that then-proposed regulations by Transport Canada which require the installation of ballast water management systems (BWMS) on Laker vessels serve no environmental purpose and because the cost of compliance is prohibitively high for U.S. vessels, Petitioner suggests that the real purpose of the regulations is to drive out U.S. vessels from this trade. Petitioner asked the Commission to issue a regulation to meet the unfair competitive conditions created by Transport Canada based on a finding that the Canadian regulations create conditions unfavorable to the Petitioners. Petitioner provided a proposed regulation that would assess a fee of 300,000.00 U.S. dollars each time a Canadian vessel enters any U.S. port.

On June 16, 2020, the Commission issued a Notice of Investigation and Request for Comments (Notice). In the Notice, the Commission concluded the petition met the threshold requirements for consideration under the Commission's regulations and initiated

an investigation into whether the proposed Transport Canada regulations create unfavorable conditions to shipping in the foreign trade of the United States. Notice of Investigation and Request for Comments: Canada Ballast Water 85 FR 37453 (June 22, 2020). The Commission designated the Deputy Managing Director to lead an investigation into the Petitioner's allegations and to prepare a report on the investigation's findings and recommendations for Commission consideration. *Id* at 37454.

As an initial step in the investigation, the Commission requested that interested persons submit views, arguments and/or data on the Petition. Between June 22, 2020, and July 22, 2020, the Commission received 21 comments. *Id*. The majority of comments received by the Commission supported the Petition and a small minority opposed. One main objection to the petition, raised by the Embassy of Canada in Washington, DC,<sup>1</sup> was that the regulatory process was ongoing, and, because the proposed regulations by Transport Canada were not final, any Commission action would be premature.

**II. Additional Developments**

Since the issuance of the June 2020 Notice and the subsequent receipt of comments, there have been developments which impact the Commission's consideration of the Petition including proposed rules within the United States and the finalization of the Canadian rule.

On October 26, 2020, the Environmental Protection Agency (EPA), published a Notice of Proposed Rulemaking, Vessel Incidental Discharge National Standards of Performance, in the **Federal Register**. See Notice of Proposed Rulemaking: Vessel Incidental Discharge National Standards of Performance, 85 FR 67818 (October 26, 2020). Like the proposed Canadian rule, the EPA's proposed rule intends to reduce the environmental impact of vessel discharges, such as ballast water. Though similar in intent, the EPA's approach to Great Lakes ballast water in their proposed rule did not align with the proposed Canadian approach and will not have an effect on the U.S. Great Lakes fleet. The Notice of Proposed Rulemaking required that comments be received on or before November 25, 2020. The EPA's next

action is not expected until sometime in 2022.

On June 23, 2021, Transport Canada issued its final rule. The general approach to the regulation of Great Lakes ballast water did not change. However, while the effective date of the final rule remains 2024, the rule delayed implementation until 2030 for vessels built prior to January 1, 2009.

**III. Investigation and Additional Request for Comments**

The Commission is continuing to investigate whether the proposed Transport Canada regulations create unfavorable conditions to shipping in the foreign trade of the United States. The Deputy Managing Director position no longer exists, and the Commission has therefore designated the General Counsel to lead the ongoing investigation into the Petitioner's allegations and to prepare a report on the investigation's findings and recommendations for Commission consideration. Considering the developments noted earlier, the Commission desires additional information. Thus, in furtherance of this investigation interested persons are requested to submit views, arguments and/or data on the Petition no later than 30 days after this publication. Submitted comments may address any aspect of the petition, but the Commission is specifically interested in comments on the following topics:

*A. The application of the final Canadian regulation.* The Commission believes that a majority of the U.S. flagged commercial vessels operating on the Great Lakes were built prior to 2009. The Commission seeks more information about the specific number of U.S. vessels to which the Canadian rule will apply, and the timing for when the Canadian rule will apply to those vessels.

*Pre-2009:* How many U.S. flag vessels operating on the Great Lakes in the U.S./Canada trade were built prior to January 1, 2009?

*Post-2009:* How many U.S. flag vessels operating on the Great Lakes in the U.S./Canada trade were built in 2009 or later?

*Historical Trade:* For both categories of vessels, what is the amount or percent of their historical and anticipated Canadian trade relative to their U.S. trade? Please specify the measure used to quantify the answer, for example is the measure based on the value of goods/revenue, the number of port calls, or any other metric.

*Canada/U.S. Flagged:* What amount or percent of the historical trade is carried by U.S. flagged vessels and what

<sup>1</sup> Unless otherwise directed by the commenter, all the comments received were treated as confidential. The Embassy of Canada requested that its comments not be treated as confidential, and they are available in the FMC reading room, <https://www2.fmc.gov/readingroom/proceeding/20-10/>.

percent is carried by Canadian flagged vessels? Please specify the metrics used to quantify the answer.

**B. The impact of the final Canadian regulation.** The Commission believes that the phased implementation of the Canadian rule could delay, and possibly eliminate, the impacts of the rule on a portion of U.S. flagged vessels. The Commission seeks specific information about the types of impacts and the timing of those impacts relative to the 2024 and 2030 implementation dates. The Commission also seeks information about the overall impact, if any, of final Canadian regulation on the Commission's consideration of the Petition:

**Contractual Impacts:** Will the final Canadian regulation affect the ability of U.S. flag vessels to negotiate contracts for the U.S./Canada trade? What are the specific or estimated economic impacts? When will any economic impacts first be realized?

**Repair/Design Impacts:** At what date will affected U.S. flag vessels be impacted by vessel repair/design considerations in order to achieve compliance with the Canadian regulations? What are the estimated costs of compliance under the final Canadian regulation?

**Business Model:** Will the final Canadian rule drive any changes in business models for U.S. flagged vessels?

For any impacts identified above, please be specific as to when an economic impact will present and upon what data the impact is based. Please identify any distinctions in impacts based on type of cargo, vessel, expiration date of contract, implementation date of proposed contract or type of carriage agreement.

**C. Other considerations.** The Commission's role in this investigation is solely to determine if there exist "conditions unfavorable to shipping in foreign trade" under 46 U.S.C. 41201. In making this determination there are other matters that may be outside the control or the authority of the Commission but nevertheless should be considered during the Commission's investigation and recommendations.

**EPA Rule:** How should the Commission consider the status of the EPA's proposed rule?

**International Convention:** Is the 2004 Ballast Water Management Convention (International Convention for the Control and Management of Ships' Ballast Water and Sediments, 2004) relevant to this Petition? Is the Canadian rule required or optional under the Convention? Have other parties to the Convention enacted a similar provision?

**Developments:** What industry or scientific developments have an impact on this Petition? Have there been any relevant developments since the Commission's initial request for comments in June 2020?

**Changes:** Have any of the analyses or projections provided to the Commission by the Petitioner changed? If so, provide the Commission with any data that has changed since the filing of the Petition and that has not been captured through answers to the questions above.

**D. Commission's future actions.** The Commission's investigation is ongoing and will consider all relevant information and potential actions, including:

**Other Information:** Do other sources of relevant information or data exist that should be considered? Where is that information/data located?

**Fee:** The original petition requested that the Commission issue a regulation that would assess a fee of 300,000.00 U.S. dollars each time a Canadian vessel enters any U.S. port. Is this request still valid and are there other corrective actions that should be considered, including requests to other agencies under 46 U.S.C. 42102(a)?

Comments in response to the questions above, or other feedback, should include objectively quantifiable data to back up any numerical or statistical information provided rather than generalized information/arguments for or against the petition.

By the Commission.

Issued: January 28, 2022.

**William Cody,**  
Secretary.

[FR Doc. 2022-02186 Filed 2-2-22; 8:45 am]

**BILLING CODE 6730-02-P**

---

## DEPARTMENT OF HEALTH AND HUMAN SERVICES

### Centers for Medicare & Medicaid Services

[Document Identifiers: CMS-10036]

#### Agency Information Collection Activities: Proposed Collection; Comment Request

**AGENCY:** Centers for Medicare & Medicaid Services, Health and Human Services (HHS).

**ACTION:** Notice.

**SUMMARY:** The Centers for Medicare & Medicaid Services (CMS) is announcing an opportunity for the public to comment on CMS' intention to collect information from the public. Under the Paperwork Reduction Act of 1995 (the

PRA), federal agencies are required to publish notice in the **Federal Register** concerning each proposed collection of information (including each proposed extension or reinstatement of an existing collection of information) and to allow 60 days for public comment on the proposed action. Interested persons are invited to send comments regarding our burden estimates or any other aspect of this collection of information, including the necessity and utility of the proposed information collection for the proper performance of the agency's functions, the accuracy of the estimated burden, ways to enhance the quality, utility, and clarity of the information to be collected, and the use of automated collection techniques or other forms of information technology to minimize the information collection burden.

**DATES:** Comments must be received by April 4, 2022.

**ADDRESSES:** When commenting, please reference the document identifier or OMB control number. To be assured consideration, comments and recommendations must be submitted in any one of the following ways:

1. **Electronically.** You may send your comments electronically to <http://www.regulations.gov>. Follow the instructions for "Comment or Submission" or "More Search Options" to find the information collection document(s) that are accepting comments.

2. **By regular mail.** You may mail written comments to the following address: CMS, Office of Strategic Operations and Regulatory Affairs, Division of Regulations Development, Attention: Document Identifier/OMB Control Number: \_\_\_\_, Room C4-26-05, 7500 Security Boulevard, Baltimore, Maryland 21244-1850.

To obtain copies of a supporting statement and any related forms for the proposed collection(s) summarized in this notice, you may make your request using one of following:

1. Access CMS' website address at website address at <https://www.cms.gov/Regulations-and-Guidance/Legislation/PaperworkReductionActof1995/PRA-Listing>.

**FOR FURTHER INFORMATION CONTACT:** William N. Parham at (410) 786-4669.

**SUPPLEMENTARY INFORMATION:**

#### Contents

This notice sets out a summary of the use and burden associated with the following information collections. More detailed information can be found in each collection's supporting statement and associated materials (see **ADDRESSES**).

**CMS-10036—IRF—PAI for the Collection of Data Pertaining to the Inpatient Rehabilitation Facility Prospective Payment System and Quality Reporting Program**

Under the PRA (44 U.S.C. 3501–3520), federal agencies must obtain approval from the Office of Management and Budget (OMB) for each collection of information they conduct or sponsor. The term “collection of information” is defined in 44 U.S.C. 3502(3) and 5 CFR 1320.3(c) and includes agency requests or requirements that members of the public submit reports, keep records, or provide information to a third party. Section 3506(c)(2)(A) of the PRA requires federal agencies to publish a 60-day notice in the **Federal Register** concerning each proposed collection of information, including each proposed extension or reinstatement of an existing collection of information, before submitting the collection to OMB for approval. To comply with this requirement, CMS is publishing this notice.

**Information Collection**

**1. Type of Information Collection Request:** Extension of a currently approved collection; **Title of Information Collection:** IRF—PAI for the Collection of Data Pertaining to the Inpatient Rehabilitation Facility Prospective Payment System and Quality Reporting Program; **Use:** We are requesting an extension of the Inpatient Rehabilitation Facility—Patient Assessment Instrument (IRF—PAI) Version 4.0 that will be effective on October 1, 2022. On November 2, 2021, we issued a final rule (86 FR 62240) which finalized proposed modifications to the effective date for the reporting of measures and certain standardized patient assessment data in the Inpatient Rehabilitation Facility Quality Reporting Program (IRF QRP). Per the final rule CMS will require IRFs to start collecting assessment data using IRF—PAI Version 4.0 beginning October 1, 2022.

The information collection request for IRF PAI 4.0 was re-approved on December 15, 2021 with an October 1,

2022 implementation date. CMS is asking for an extension of the approved IRF—PAI Version 4.0, which expires on December 31, 2022. The burden associated with this requirement is staff time required to complete and encode the data from the IRF—PAI. The burden associated with collecting and transmitting the data is unaffected by the proposed extension to the assessment instrument.

The IRF—PAI is required by the CMS as part of the Inpatient Rehabilitation Facility Prospective Payment System (IRF PPS). CMS uses the data to determine the payment for each Medicare Part A fee-for-service patient and Medicare Part C (Medicare Advantage) admitted to an inpatient rehabilitation unit or hospital. The IRF—PAI is also used to gather data for the IRF Quality Reporting Program (IRF QRP). **Form Number:** CMS–10036 (OMB control number: 0938–0842); **Frequency:** Annually; **Affected Public:** Private Sector: Business and for-profit and Not-for-profit, State, Local or Tribal Government and Federal Government; **Number of Respondents:** 1,122; **Total Annual Responses:** 411,622; **Total Annual Hours:** 704,747. For policy questions regarding this collection, contact Ariel Adams at 410–786–8571.)

Dated: January 28, 2022.

**William N. Parham, III,**  
*Director, Paperwork Reduction Staff, Office of Strategic Operations and Regulatory Affairs.*

[FR Doc. 2022–02185 Filed 2–2–22; 8:45 am]

**BILLING CODE 4120–01–P**

**DEPARTMENT OF HEALTH AND HUMAN SERVICES**

**Administration for Children and Families**

**Submission for OMB Review; ACF Uniform Project Description (UPD)**

**AGENCY:** Office of Administration, Office of Grants Policy, Administration for Children and Families, HHS.

**ACTION:** Request for public comment.

**SUMMARY:** The Administration for Children and Families (ACF) is requesting a 3-year extension of the ACF Uniform Project Description (UPD) (OMB #0970–0139, expiration 2/28/2022). There are no changes requested to the form. ACF expects to submit a request for revisions in 2022, which will include standard comment periods.

**DATES:** *Comments due within 30 days of publication.* OMB must make a decision about the collection of information between 30 and 60 days after publication of this document in the **Federal Register**. Therefore, a comment is best assured of having its full effect if OMB receives it within 30 days of publication.

**ADDRESSES:** Written comments and recommendations for the proposed information collection should be sent within 30 days of publication of this notice to [www.reginfo.gov/public/do/PRAMain](http://www.reginfo.gov/public/do/PRAMain). Find this particular information collection by selecting “Currently under 30-day Review—Open for Public Comments” or by using the search function. You can also request copies of the proposed collection of information by emailing [infocollection@acf.hhs.gov](mailto:infocollection@acf.hhs.gov). Identify all requests by the title of the information collection.

**SUPPLEMENTARY INFORMATION:**

**Description:** The proposed information collection would renew the ACF UPD. The UPD provides a uniform format for applicants to submit project information in response to ACF discretionary Notices of Funding Opportunities. The UPD requires applicants to describe how program objectives will be achieved and provide a rationale for the project’s budgeted costs. All ACF discretionary grant programs are required to use the UPD.

ACF uses this information, along with other OMB-approved information collections (Standard Forms), to evaluate and rank applications. Use of the UPD protects the integrity of the ACF award selection process.

**Respondents:** Applicants responding to ACF Discretionary Notices of Funding Opportunities.

**ANNUAL BURDEN ESTIMATES**

Instrument	Total number of respondents	Annual number of responses per respondent	Average burden hours per response	Annual burden hours
ACF Uniform Project Description .....	4,170	1	60	250,200

*Estimated Total Annual Burden Hours:* 250,200.

*Authority:* 45 CFR 75.203–75.204 and 45 CFR part 75, Appendix I.

**Mary B. Jones,**

*ACF/OPRE Certifying Officer.*

[FR Doc. 2022–02177 Filed 2–2–22; 8:45 am]

**BILLING CODE 4184–01–P**

## DEPARTMENT OF HEALTH AND HUMAN SERVICES

### Meetings of the Presidential Advisory Council on Combating Antibiotic-Resistant Bacteria

**AGENCY:** Department of Health and Human Services, Office of the Secretary, Office of the Assistant Secretary for Health.

**ACTION:** Notice.

**SUMMARY:** As stipulated by the Federal Advisory Committee Act, the Department of Health and Human Services (HHS) is hereby giving notice that a meeting is scheduled to be held for the Presidential Advisory Council on Combating Antibiotic-Resistant Bacteria (PACCARB). The meeting will be open to the public via Zoom and teleconference; a pre-registered public comment session will be held during the meeting. Pre-registration is required for members of the public who wish to present their comments at the meeting via Zoom/teleconference. Individuals who wish to send in their written public comment should send an email to [CARB@hhs.gov](mailto:CARB@hhs.gov). Registration information is available on the website <http://www.hhs.gov/paccarb> and must be completed by February 25, 2022 for the March 2, 2022 Public Meeting. Additional information about registering for the meeting and providing public comment can be obtained at <http://www.hhs.gov/paccarb> on the Upcoming Meetings page.

**DATES:** The meeting is scheduled to be held on March 2, 2022, from 10:00 a.m. to 4:00 p.m. ET (times are tentative and subject to change). The confirmed times and agenda items for the meeting will be posted on the website for the PACCARB at <http://www.hhs.gov/paccarb> when this information becomes available. Pre-registration for attending the meeting is strongly suggested and should be completed no later than February 25, 2022.

**ADDRESSES:** Instructions regarding attending this meeting virtually will be posted at least one week prior to the meeting at: <http://www.hhs.gov/paccarb>.

#### FOR FURTHER INFORMATION CONTACT:

Jomana Musmar, M.S., Ph.D., Designated Federal Officer, Presidential Advisory Council on Combating Antibiotic-Resistant Bacteria, Office of the Assistant Secretary for Health, U.S. Department of Health and Human Services, Room L616, Switzer Building, 330 C St. SW, Washington, DC 20024. Phone: 202–746–1512; Email: [CARB@hhs.gov](mailto:CARB@hhs.gov).

**SUPPLEMENTARY INFORMATION:** The Presidential Advisory Council on Combating Antibiotic-Resistant Bacteria (PACCARB), established by Executive Order 13676, is continued by Section 505 of Public Law 116–22, the Pandemic and All-Hazards Preparedness and Advancing Innovation Act of 2019 (PAHPAIA). Activities and duties of the Advisory Council are governed by the provisions of the Federal Advisory Committee Act (FACA), Public Law 92–463, as amended (5 U.S.C. App.), which sets forth standards for the formation and use of federal advisory committees.

The PACCARB shall advise and provide information and recommendations to the Secretary regarding programs and policies intended to reduce or combat antibiotic-resistant bacteria that may present a public health threat and improve capabilities to prevent, diagnose, mitigate, or treat such resistance. The PACCARB shall function solely for advisory purposes.

Such advice, information, and recommendations may be related to improving: The effectiveness of antibiotics; research and advanced research on, and the development of, improved and innovative methods for combating or reducing antibiotic resistance, including new treatments, rapid point-of-care diagnostics, alternatives to antibiotics, including alternatives to animal antibiotics, and antimicrobial stewardship activities; surveillance of antibiotic-resistant bacterial infections, including publicly available and up-to-date information on resistance to antibiotics; education for health care providers and the public with respect to up-to-date information on antibiotic resistance and ways to reduce or combat such resistance to antibiotics related to humans and animals; methods to prevent or reduce the transmission of antibiotic-resistant bacterial infections; including stewardship programs; and coordination with respect to international efforts in order to inform and advance the United States capabilities to combat antibiotic resistance.

The March 2, 2022, public meeting will be dedicated to providing a One Health retrospective on past novel viral outbreaks and how they impacted antimicrobial use, resistance, and stewardship. The meeting agenda will be posted on the PACCARB website at <http://www.hhs.gov/paccarb> when it has been finalized. All agenda items are tentative and subject to change. Instructions regarding attending the meeting virtually will be posted at least one week prior to the meeting at: <http://www.hhs.gov/paccarb>.

Members of the public will have the opportunity to provide comments live during the March meeting by pre-registering online at <http://www.hhs.gov/paccarb>. Pre-registration is required for participation in this session with limited spots available. Written public comments can also be emailed to [CARB@hhs.gov](mailto:CARB@hhs.gov) by midnight February 25, 2022, and should be limited to no more than one page. All public comments received prior to February 25, 2022, will be provided to the Advisory Council members. Additionally, companies and/or organizations involved in combating antibiotic resistance have an opportunity to present their work to members of the Advisory Council live during an Innovation Spotlight. Pre-registration is required for participation, with limited spots available. All information regarding this session can also be found online at <http://www.hhs.gov/paccarb>.

Dated: January 27, 2022.

**Jomana F. Musmar,**

*Designated Federal Officer, Presidential Advisory Council on Combating Antibiotic-Resistant Bacteria, Office of the Assistant Secretary for Health.*

[FR Doc. 2022–02291 Filed 2–2–22; 8:45 am]

**BILLING CODE 4150–44–P**

## DEPARTMENT OF HEALTH AND HUMAN SERVICES

### National Institutes of Health

#### Center for Scientific Review; Amended Notice of Meeting

Notice is hereby given of a change in the meeting of the Arthritis, Connective Tissue and Skin Study Section, February 17–18, 2022, 9:00 a.m. to 7:00 p.m., which was published in the **Federal Register** on January 19, 2022, FR DOC 2022–00962, 87 FR 2878.

This notice is being amended to change the meeting date from February 17–18, 2022, 9:00 a.m. to 7:00 p.m. to February 16–18, 2022, 12:00 p.m. to 7:00 p.m. The meeting place remains the



same. The meeting is closed to the public.

Dated: January 28, 2022.

**Melanie J. Pantoja,**

*Program Analyst, Office of Federal Advisory Committee Policy.*

[FR Doc. 2022-02201 Filed 2-2-22; 8:45 am]

**BILLING CODE 4140-01-P**

## DEPARTMENT OF HEALTH AND HUMAN SERVICES

### National Institutes of Health

#### Center for Scientific Review; Notice of Closed Meetings

Pursuant to section 10(d) of the Federal Advisory Committee Act, as amended, notice is hereby given of the following meetings.

The meetings will be closed to the public in accordance with the provisions set forth in sections 552b(c)(4) and 552b(c)(6), Title 5 U.S.C., as amended. The grant applications and the discussions could disclose confidential trade secrets or commercial property such as patentable material, and personal information concerning individuals associated with the grant applications, the disclosure of which would constitute a clearly unwarranted invasion of personal privacy.

*Name of Committee:* Center for Scientific Review Special Emphasis Panel; Therapeutic Development and Preclinical Studies.

*Date:* March 3-4, 2022.

*Time:* 9:00 a.m. to 7:00 p.m.

*Agenda:* To review and evaluate grant applications.

*Place:* National Institutes of Health, Rockledge II, 6701 Rockledge Drive, Bethesda, MD 20892 (Virtual Meeting).

*Contact Person:* Richard D. Schneiderman, Ph.D., Scientific Review Officer, Center for Scientific Review, National Institutes of Health, 6701 Rockledge Drive, Room 4138, Bethesda, MD 20817, 301-402-3995, [richard.schneiderman@nih.gov](mailto:richard.schneiderman@nih.gov).

*Name of Committee:* Center for Scientific Review Special Emphasis Panel; PAR 20-117: Maximizing Investigators' Research Award (MIRA) for Early Stage Investigators (R35—Clinical Trial Optional).

*Date:* March 7-8, 2022.

*Time:* 9:00 a.m. to 8:00 p.m.

*Agenda:* To review and evaluate grant applications.

*Place:* National Institutes of Health, Rockledge II, 6701 Rockledge Drive, Bethesda, MD 20892 (Virtual Meeting).

*Contact Person:* Altaf Ahmad Dar, Ph.D., Scientific Review Officer, Center for Scientific Review, National Institutes of Health, 6701 Rockledge Drive, Bethesda, MD 20892, 415-254-1803, [altaf.dar@nih.gov](mailto:altaf.dar@nih.gov).

*Name of Committee:* Center for Scientific Review Special Emphasis Panel; Small Business: Innovative Immunology.

*Date:* March 9, 2022.

*Time:* 10:00 a.m. to 8:30 p.m.

*Agenda:* To review and evaluate grant applications.

*Place:* National Institutes of Health, Rockledge II, 6701 Rockledge Drive, Bethesda, MD 20892 (Virtual Meeting).

*Contact Person:* Dayadevi Balappa Jirage, Ph.D., Scientific Review Officer, Center for Scientific Review, National Institutes of Health, 6700B Rockledge Drive, Room 4422, Bethesda, MD 20892, (301) 867-5309, [jiragedb@csr.nih.gov](mailto:jiragedb@csr.nih.gov).

*Name of Committee:* Center for Scientific Review Special Emphasis Panel; Member Conflict: Bioengineering, Surgery, Anesthesiology and Trauma.

*Date:* March 9, 2022.

*Time:* 10:00 a.m. to 6:00 p.m.

*Agenda:* To review and evaluate grant applications.

*Place:* National Institutes of Health, Rockledge II, 6701 Rockledge Drive, Bethesda, MD 20892 (Virtual Meeting).

*Contact Person:* Donald Scott Wright, Ph.D., Scientific Review Officer, Center for Scientific Review, National Institutes of Health, 6701 Rockledge Drive, Room 5108, MSC 7854, Bethesda, MD 20892, (301) 435-8363, [wrightds@csr.nih.gov](mailto:wrightds@csr.nih.gov).

*Name of Committee:* Center for Scientific Review Special Emphasis Panel; Electronic Nicotine Delivery Systems and Tobacco Use.

*Date:* March 9, 2022.

*Time:* 11:00 a.m. to 9:00 p.m.

*Agenda:* To review and evaluate grant applications.

*Place:* National Institutes of Health, Rockledge II, 6701 Rockledge Drive, Bethesda, MD 20892 (Virtual Meeting).

*Contact Person:* Kimm Hamann, Ph.D., Scientific Review Officer, Center for Scientific Review, National Institutes of Health, 6701 Rockledge Drive, Room 4118A, MSC 7814, Bethesda, MD 20892, 301-435-5575, [hamannkj@csr.nih.gov](mailto:hamannkj@csr.nih.gov).

*Name of Committee:* Center for Scientific Review Special Emphasis Panel; Member Conflict: Skeletal Muscle and Exercise Physiology.

*Date:* March 9, 2022.

*Time:* 11:00 a.m. to 5:00 p.m.

*Agenda:* To review and evaluate grant applications.

*Place:* National Institutes of Health, Rockledge II, 6701 Rockledge Drive, Bethesda, MD 20892 (Virtual Meeting).

*Contact Person:* Carmen Bertoni, Ph.D., Scientific Review Officer, Center for Scientific Review, National Institutes of Health, 6701 Rockledge Drive, Room 805B, Bethesda, MD 20892, (301) 867-5309, [bertonic2@csr.nih.gov](mailto:bertonic2@csr.nih.gov).

*Name of Committee:* Infectious Diseases and Immunology B Integrated Review Group; Clinical Research and Field Studies of Infectious Diseases Study Section.

*Date:* March 10-11, 2022.

*Time:* 9:00 a.m. to 8:00 p.m.

*Agenda:* To review and evaluate grant applications.

*Place:* National Institutes of Health, Rockledge II, 6701 Rockledge Drive, Bethesda, MD 20892 (Virtual Meeting).

*Contact Person:* Pauline Cupit, Ph.D., Scientific Review Officer, Center for Scientific Review, National Institute of Health, 6701 Rockledge Drive, Bethesda, MD 20892, 301-827-3275, [cupitcunninghpm@mail.nih.gov](mailto:cupitcunninghpm@mail.nih.gov).

*Name of Committee:* Infectious Diseases and Immunology A Integrated Review Group; Innate Immunity and Inflammation Study Section.

*Date:* March 10-11, 2022.

*Time:* 9:30 a.m. to 6:30 p.m.

*Agenda:* To review and evaluate grant applications.

*Place:* National Institutes of Health, Rockledge II, 6701 Rockledge Drive, Bethesda, MD 20892 (Virtual Meeting).

*Contact Person:* Shahrooz Vahedi, Ph.D., Scientific Review Officer, Center for Scientific Review, National Institutes of Health, 6701 Rockledge Drive, Room 810G, Bethesda, MD 20892, (301) 496-9322, [vahedis@mail.nih.gov](mailto:vahedis@mail.nih.gov).

*Name of Committee:* Biological Chemistry and Macromolecular Biophysics Integrated Review Group; Maximizing Investigators' Research Award B Study Section.

*Date:* March 10-11, 2022.

*Time:* 10:00 a.m. to 9:00 p.m.

*Agenda:* To review and evaluate grant applications.

*Place:* National Institutes of Health, Rockledge II, 6701 Rockledge Drive, Bethesda, MD 20892 (Virtual Meeting).

*Contact Person:* Sudha Veeraraghavan, Ph.D., Scientific Review Officer, Center for Scientific Review, National Institutes of Health, 6701 Rockledge Drive, Room 4166, MSC 7846, Bethesda, MD 20892, (301) 827-5263, [sudha.veeraraghavan@nih.gov](mailto:sudha.veeraraghavan@nih.gov).

*Name of Committee:* Molecular, Cellular and Developmental Neuroscience Integrated Review Group; Cellular and Molecular Biology of Neurodegeneration Study Section.

*Date:* March 10-11, 2022.

*Time:* 10:00 a.m. to 5:00 p.m.

*Agenda:* To review and evaluate grant applications.

*Place:* National Institutes of Health, Rockledge II, 6701 Rockledge Drive, Bethesda, MD 20892 (Virtual Meeting).

*Contact Person:* Laurent Taupenot, Ph.D., Scientific Review Officer, Center for Scientific Review, National Institutes of Health, 6701 Rockledge Drive, Room 4188, MSC 7850, Bethesda, MD 20892, 301-435-1203, [laurent.taupenot@nih.gov](mailto:laurent.taupenot@nih.gov).

(Catalogue of Federal Domestic Assistance Program Nos. 93.306, Comparative Medicine; 93.333, Clinical Research; 93.306, 93.333, 93.337, 93.393-93.396, 93.837-93.844, 93.846-93.878, 93.892, 93.893, National Institutes of Health, HHS)

Dated: January 28, 2022.

**Melanie J. Pantoja,**

*Program Analyst, Office of Federal Advisory Committee Policy.*

[FR Doc. 2022-02199 Filed 2-2-22; 8:45 am]

**BILLING CODE 4140-01-P**

**DEPARTMENT OF HOMELAND SECURITY****Federal Emergency Management Agency****[Internal Agency Docket No. FEMA-4633-DR; Docket ID FEMA-2021-0001]****Arkansas; Major Disaster and Related Determinations****AGENCY:** Federal Emergency Management Agency, DHS.**ACTION:** Notice.**SUMMARY:** This is a notice of the Presidential declaration of a major disaster for the State of Arkansas (FEMA-4633-DR), dated December 23, 2021, and related determinations.**DATES:** The declaration was issued December 23, 2021.**FOR FURTHER INFORMATION CONTACT:** Dean Webster, Office of Response and Recovery, Federal Emergency Management Agency, 500 C Street SW, Washington, DC 20472, (202) 646-2833.**SUPPLEMENTARY INFORMATION:** Notice is hereby given that, in a letter dated December 23, 2021, the President issued a major disaster declaration under the authority of the Robert T. Stafford Disaster Relief and Emergency Assistance Act, 42 U.S.C. 5121 *et seq.* (the "Stafford Act"), as follows:

I have determined that the damage in certain areas of the State of Arkansas resulting from severe storms and tornadoes during the period of December 10 to December 11, 2021, is of sufficient severity and magnitude to warrant a major disaster declaration under the Robert T. Stafford Disaster Relief and Emergency Assistance Act, 42 U.S.C. 5121 *et seq.* (the "Stafford Act"). Therefore, I declare that such a major disaster exists in the State of Arkansas.

In order to provide Federal assistance, you are hereby authorized to allocate from funds available for these purposes such amounts as you find necessary for Federal disaster assistance and administrative expenses.

You are authorized to provide Individual Assistance in the designated areas and Hazard Mitigation throughout the State. Consistent with the requirement that Federal assistance be supplemental, any Federal funds provided under the Stafford Act for Hazard Mitigation and Other Needs Assistance under section 408 will be limited to 75 percent of the total eligible costs.

Further, you are authorized to make changes to this declaration for the approved assistance to the extent allowable under the Stafford Act.

The time period prescribed for the implementation of section 310(a), Priority to Certain Applications for Public Facility and Public Housing Assistance, 42 U.S.C. 5153, shall be for a period not to exceed six months after the date of this declaration.

The Federal Emergency Management Agency (FEMA) hereby gives notice that pursuant to the authority vested in the Administrator, under Executive Order 12148, as amended, Jerry S. Thomas, of FEMA is appointed to act as the Federal Coordinating Officer for this major disaster.

The following areas of the State of Arkansas have been designated as adversely affected by this major disaster:

Craighead, Jackson, Mississippi, Poinsett, and Woodruff Counties for Individual Assistance.

All areas within the State of Arkansas are eligible for assistance under the Hazard Mitigation Grant Program.

The following Catalog of Federal Domestic Assistance Numbers (CFDA) are to be used for reporting and drawing funds: 97.030, Community Disaster Loans; 97.031, Cora Brown Fund; 97.032, Crisis Counseling; 97.033, Disaster Legal Services; 97.034, Disaster Unemployment Assistance (DUA); 97.046, Fire Management Assistance Grant; 97.048, Disaster Housing Assistance to Individuals and Households in Presidentially Declared Disaster Areas; 97.049, Presidentially Declared Disaster Assistance—Disaster Housing Operations for Individuals and Households; 97.050, Presidentially Declared Disaster Assistance to Individuals and Households—Other Needs; 97.036, Disaster Grants—Public Assistance (Presidentially Declared Disasters); 97.039, Hazard Mitigation Grant.

**Deanne Criswell,***Administrator, Federal Emergency Management Agency.*

[FR Doc. 2022-02248 Filed 2-2-22; 8:45 am]

**BILLING CODE 9111-23-P****DEPARTMENT OF HOMELAND SECURITY****Federal Emergency Management Agency****[Internal Agency Docket No. FEMA-3575-EM; Docket ID FEMA-2021-0001]****Kentucky; Emergency and Related Determinations****AGENCY:** Federal Emergency Management Agency, DHS.**ACTION:** Notice.**SUMMARY:** This is a notice of the Presidential declaration of an emergency for the Commonwealth of Kentucky (FEMA-3575-EM), dated December 11, 2021, and related determinations.**DATES:** The declaration was issued December 11, 2021.**FOR FURTHER INFORMATION CONTACT:** Dean Webster, Office of Response and Recovery, Federal Emergency

Management Agency, 500 C Street SW, Washington, DC 20472, (202) 646-2833.

**SUPPLEMENTARY INFORMATION:** Notice is hereby given that, in a letter dated December 11, 2021, the President issued an emergency declaration under the authority of the Robert T. Stafford Disaster Relief and Emergency Assistance Act, 42 U.S.C. 5121-5207 (the Stafford Act), as follows:

I have determined that the emergency conditions in certain areas of the Commonwealth of Kentucky resulting from severe storms, straight-line winds, flooding, and tornadoes beginning on December 10, 2021, and continuing, are of sufficient severity and magnitude to warrant an emergency declaration under the Robert T. Stafford Disaster Relief and Emergency Assistance Act, 42 U.S.C. 5121 *et seq.* ("the Stafford Act"). Therefore, I declare that such an emergency exists in the Commonwealth of Kentucky.

You are authorized to provide appropriate assistance for required emergency measures, authorized under Title V of the Stafford Act, to save lives and to protect property and public health and safety, and to lessen or avert the threat of a catastrophe in the designated areas. Specifically, you are authorized to provide assistance for emergency protective measures (Category B), including direct Federal assistance under the Public Assistance program.

Consistent with the requirement that Federal assistance be supplemental, any Federal funds provided under the Stafford Act for Public Assistance will be limited to 75 percent of the total eligible costs. In order to provide Federal assistance, you are hereby authorized to allocate from funds available for these purposes such amounts as you find necessary for Federal emergency assistance and administrative expenses.

Further, you are authorized to make changes to this declaration for the approved assistance to the extent allowable under the Stafford Act.

The Federal Emergency Management Agency (FEMA) hereby gives notice that pursuant to the authority vested in the Administrator, Department of Homeland Security, under Executive Order 12148, as amended, John Brogan, of FEMA is appointed to act as the Federal Coordinating Officer for this declared emergency.

The following areas of the Commonwealth of Kentucky have been designated as adversely affected by this declared emergency:

Breckenridge, Bullitt, Caldwell, Fulton, Graves, Grayson, Hickman, Hopkins, Lyon, Meade, Muhlenberg, Ohio, Shelby, Spencer, and Warren Counties for emergency protective measures (Category B), including direct federal assistance, under the Public Assistance program.

The following Catalog of Federal Domestic Assistance Numbers (CFDA) are to be used for reporting and drawing funds: 97.030, Community Disaster Loans; 97.031, Cora

Brown Fund; 97.032, Crisis Counseling; 97.033, Disaster Legal Services; 97.034, Disaster Unemployment Assistance (DUA); 97.046, Fire Management Assistance Grant; 97.048, Disaster Housing Assistance to Individuals and Households In Presidentially Declared Disaster Areas; 97.049, Presidentially Declared Disaster Assistance—Disaster Housing Operations for Individuals and Households; 97.050, Presidentially Declared Disaster Assistance to Individuals and Households—Other Needs; 97.036, Disaster Grants—Public Assistance (Presidentially Declared Disasters); 97.039, Hazard Mitigation Grant.

**Deanne Criswell,**

*Administrator, Federal Emergency Management Agency.*

[FR Doc. 2022–02225 Filed 2–2–22; 8:45 am]

**BILLING CODE 9111–23–P**

## DEPARTMENT OF HOMELAND SECURITY

### Federal Emergency Management Agency

[Internal Agency Docket No. FEMA–4393–DR; Docket ID FEMA–2022–0001]

#### North Carolina; Amendment No. 14 to Notice of a Major Disaster Declaration

**AGENCY:** Federal Emergency Management Agency, DHS.

**ACTION:** Notice.

**SUMMARY:** This notice amends the notice of a major disaster declaration for the State of North Carolina (FEMA–4393–DR), dated September 14, 2018, and related determinations.

**DATES:** This change occurred on January 18, 2022.

**FOR FURTHER INFORMATION CONTACT:** Dean Webster, Office of Response and Recovery, Federal Emergency Management Agency, 500 C Street SW, Washington, DC 20472, (202) 646–2833.

**SUPPLEMENTARY INFORMATION:** The Federal Emergency Management Agency (FEMA) hereby gives notice that pursuant to the authority vested in the Administrator, under Executive Order 12148, as amended, Kevin A. Wallace, of FEMA is appointed to act as the Federal Coordinating Officer for this disaster.

This action terminates the appointment of Myra M. Shird as Federal Coordinating Officer for this disaster.

The following Catalog of Federal Domestic Assistance Numbers (CFDA) are to be used for reporting and drawing funds: 97.030, Community Disaster Loans; 97.031, Cora Brown Fund; 97.032, Crisis Counseling; 97.033, Disaster Legal Services; 97.034, Disaster Unemployment Assistance (DUA); 97.046, Fire Management Assistance Grant;

97.048, Disaster Housing Assistance to Individuals and Households In Presidentially Declared Disaster Areas; 97.049, Presidentially Declared Disaster Assistance—Disaster Housing Operations for Individuals and Households; 97.050, Presidentially Declared Disaster Assistance to Individuals and Households—Other Needs; 97.036, Disaster Grants—Public Assistance (Presidentially Declared Disasters); 97.039, Hazard Mitigation Grant.

**Deanne Criswell,**

*Administrator, Federal Emergency Management Agency.*

[FR Doc. 2022–02252 Filed 2–2–22; 8:45 am]

**BILLING CODE 9111–23–P**

## DEPARTMENT OF HOMELAND SECURITY

### Federal Emergency Management Agency

[Internal Agency Docket No. FEMA–4630–DR; Docket ID FEMA–2022–0001]

#### Kentucky; Amendment No. 7 to Notice of a Major Disaster Declaration

**AGENCY:** Federal Emergency Management Agency, DHS.

**ACTION:** Notice.

**SUMMARY:** This notice amends the notice of a major disaster for the Commonwealth of Kentucky (FEMA–4630–DR), dated December 12, 2021, and related determinations.

**DATES:** This amendment was issued January 8, 2022.

**FOR FURTHER INFORMATION CONTACT:** Dean Webster, Office of Response and Recovery, Federal Emergency Management Agency, 500 C Street SW, Washington, DC 20472, (202) 646–2833.

**SUPPLEMENTARY INFORMATION:** Notice is hereby given that, in a letter dated January 8, 2022, the President amended the cost-sharing arrangements regarding Federal funds provided under the authority of the Robert T. Stafford Disaster Relief and Emergency Assistance Act, 42 U.S.C. 5121 *et seq.* (the “Stafford Act”), in a letter to Deanne Criswell, Administrator, Federal Emergency Management Agency, Department of Homeland Security, under Executive Order 12148, as follows:

I have determined that the damage in certain areas of the Commonwealth of Kentucky resulting from severe storms, straight-line winds, flooding, and tornadoes during the period of December 10 to December 11, 2021, is of sufficient severity and magnitude that special cost sharing arrangements are warranted regarding Federal funds provided under the Robert T. Stafford Disaster Relief and Emergency

Assistance Act, 42 U.S.C. 5121 *et seq.* (the “Stafford Act”).

Therefore, I amend my declarations of December 12, 2021, and December 15, 2021, to authorize Federal funds for debris removal and emergency protective measures, including direct Federal assistance, at 100 percent of the total eligible costs for a 30-day period of the Commonwealth’s choosing within the first 120 days of the declaration. (The following Catalog of Federal Domestic Assistance Numbers (CFDA) are to be used for reporting and drawing funds: 97.030, Community Disaster Loans; 97.031, Cora Brown Fund; 97.032, Crisis Counseling; 97.033, Disaster Legal Services; 97.034, Disaster Unemployment Assistance (DUA); 97.046, Fire Management Assistance Grant; 97.048, Disaster Housing Assistance to Individuals and Households In Presidentially Declared Disaster Areas; 97.049, Presidentially Declared Disaster Assistance—Disaster Housing Operations for Individuals and Households; 97.050, Presidentially Declared Disaster Assistance to Individuals and Households—Other Needs; 97.036, Disaster Grants—Public Assistance (Presidentially Declared Disasters); 97.039, Hazard Mitigation Grant).

**Deanne Criswell,**

*Administrator, Federal Emergency Management Agency.*

[FR Doc. 2022–02244 Filed 2–2–22; 8:45 am]

**BILLING CODE 9111–23–P**

## DEPARTMENT OF HOMELAND SECURITY

### Federal Emergency Management Agency

[Internal Agency Docket No. FEMA–4588–DR; Docket ID FEMA–2022–0001]

#### North Carolina; Amendment No. 1 to Notice of a Major Disaster Declaration

**AGENCY:** Federal Emergency Management Agency, DHS.

**ACTION:** Notice.

**SUMMARY:** This notice amends the notice of a major disaster declaration for the State of North Carolina (FEMA–4588–DR), dated March 3, 2021, and related determinations.

**DATES:** This change occurred on January 18, 2022.

**FOR FURTHER INFORMATION CONTACT:** Dean Webster, Office of Response and Recovery, Federal Emergency Management Agency, 500 C Street SW, Washington, DC 20472, (202) 646–2833.

**SUPPLEMENTARY INFORMATION:** The Federal Emergency Management Agency (FEMA) hereby gives notice that pursuant to the authority vested in the Administrator, under Executive Order 12148, as amended, Kevin A. Wallace, of FEMA is appointed to act as the

Federal Coordinating Officer for this disaster.

This action terminates the appointment of Myra M. Shird as Federal Coordinating Officer for this disaster.

The following Catalog of Federal Domestic Assistance Numbers (CFDA) are to be used for reporting and drawing funds: 97.030, Community Disaster Loans; 97.031, Cora Brown Fund; 97.032, Crisis Counseling; 97.033, Disaster Legal Services; 97.034, Disaster Unemployment Assistance (DUA); 97.046, Fire Management Assistance Grant; 97.048, Disaster Housing Assistance to Individuals and Households In Presidentially Declared Disaster Areas; 97.049, Presidentially Declared Disaster Assistance—Disaster Housing Operations for Individuals and Households; 97.050, Presidentially Declared Disaster Assistance to Individuals and Households—Other Needs; 97.036, Disaster Grants—Public Assistance (Presidentially Declared Disasters); 97.039, Hazard Mitigation Grant.

**Deanne Criswell,**

*Administrator, Federal Emergency Management Agency.*

[FR Doc. 2022–02258 Filed 2–2–22; 8:45 am]

**BILLING CODE 9111–23–P**

## DEPARTMENT OF HOMELAND SECURITY

### Federal Emergency Management Agency

[Internal Agency Docket No. FEMA–4626–DR; Docket ID FEMA–2022–0001]

#### Mississippi; Amendment No. 2 to Notice of a Major Disaster Declaration

**AGENCY:** Federal Emergency Management Agency, DHS.

**ACTION:** Notice.

**SUMMARY:** This notice amends the notice of a major disaster declaration for State of Mississippi (FEMA–4626–DR), dated October 22, 2021, and related determinations.

**DATES:** This change occurred on January 14, 2022.

**FOR FURTHER INFORMATION CONTACT:** Dean Webster, Office of Response and Recovery, Federal Emergency Management Agency, 500 C Street SW, Washington, DC 20472, (202) 646–2833.

**SUPPLEMENTARY INFORMATION:** The Federal Emergency Management Agency (FEMA) hereby gives notice that pursuant to the authority vested in the Administrator, under Executive Order 12148, as amended, James R. Stephenson, of FEMA is appointed to act as the Federal Coordinating Officer for this disaster.

This action terminates the appointment of Brett H. Howard as

Federal Coordinating Officer for this disaster.

The following Catalog of Federal Domestic Assistance Numbers (CFDA) are to be used for reporting and drawing funds: 97.030, Community Disaster Loans; 97.031, Cora Brown Fund; 97.032, Crisis Counseling; 97.033, Disaster Legal Services; 97.034, Disaster Unemployment Assistance (DUA); 97.046, Fire Management Assistance Grant; 97.048, Disaster Housing Assistance to Individuals and Households In Presidentially Declared Disaster Areas; 97.049, Presidentially Declared Disaster Assistance—Disaster Housing Operations for Individuals and Households; 97.050, Presidentially Declared Disaster Assistance to Individuals and Households—Other Needs; 97.036, Disaster Grants—Public Assistance (Presidentially Declared Disasters); 97.039, Hazard Mitigation Grant.

**Deanne Criswell,**

*Administrator, Federal Emergency Management Agency.*

[FR Doc. 2022–02231 Filed 2–2–22; 8:45 am]

**BILLING CODE 9111–23–P**

## DEPARTMENT OF HOMELAND SECURITY

### Federal Emergency Management Agency

[Internal Agency Docket No. FEMA–4611–DR; Docket ID FEMA–2021–0001]

#### Louisiana; Amendment No. 5 to Notice of a Major Disaster Declaration

**AGENCY:** Federal Emergency Management Agency, DHS.

**ACTION:** Notice.

**SUMMARY:** This notice amends the notice of a major disaster declaration for the State of Louisiana (FEMA–4611–DR), dated August 29, 2021, and related determinations.

**DATES:** This amendment was issued December 14, 2021.

**FOR FURTHER INFORMATION CONTACT:** Dean Webster, Office of Response and Recovery, Federal Emergency Management Agency, 500 C Street SW, Washington, DC 20472, (202) 646–2833.

**SUPPLEMENTARY INFORMATION:** The notice of a major disaster declaration for the State of Louisiana is hereby amended to include the following areas among those areas determined to have been adversely affected by the event declared a major disaster by the President in his declaration of August 29, 2021.

Ascension, Assumption, East Baton Rouge, East Feliciana, Iberville, Livingston, Pointe Coupee, St. Helena, St. Martin, St. Mary, and West Feliciana Parishes for permanent work [Categories C–G] (already designated for Individual Assistance and assistance for

debris removal and emergency protective measures [Categories A and B], including direct federal assistance, under the Public Assistance program).

The following Catalog of Federal Domestic Assistance Numbers (CFDA) are to be used for reporting and drawing funds: 97.030, Community Disaster Loans; 97.031, Cora Brown Fund; 97.032, Crisis Counseling; 97.033, Disaster Legal Services; 97.034, Disaster Unemployment Assistance (DUA); 97.046, Fire Management Assistance Grant; 97.048, Disaster Housing Assistance to Individuals and Households In Presidentially Declared Disaster Areas; 97.049, Presidentially Declared Disaster Assistance—Disaster Housing Operations for Individuals and Households; 97.050, Presidentially Declared Disaster Assistance to Individuals and Households—Other Needs; 97.036, Disaster Grants—Public Assistance (Presidentially Declared Disasters); 97.039, Hazard Mitigation Grant.

**Deanne Criswell,**

*Administrator, Federal Emergency Management Agency.*

[FR Doc. 2022–02260 Filed 2–2–22; 8:45 am]

**BILLING CODE 9111–23–P**

## DEPARTMENT OF HOMELAND SECURITY

### Federal Emergency Management Agency

[Internal Agency Docket No. FEMA–4630–DR; Docket ID FEMA–2021–0001]

#### Kentucky; Major Disaster and Related Determinations

**AGENCY:** Federal Emergency Management Agency, DHS.

**ACTION:** Notice.

**SUMMARY:** This is a notice of the Presidential declaration of a major disaster for the Commonwealth of Kentucky (FEMA–4630–DR), dated December 12, 2021, and related determinations.

**DATES:** The declaration was issued December 12, 2021.

**FOR FURTHER INFORMATION CONTACT:** Dean Webster, Office of Response and Recovery, Federal Emergency Management Agency, 500 C Street SW, Washington, DC 20472, (202) 646–2833.

**SUPPLEMENTARY INFORMATION:** Notice is hereby given that, in a letter dated December 12, 2021, the President issued a major disaster declaration under the authority of the Robert T. Stafford Disaster Relief and Emergency Assistance Act, 42 U.S.C. 5121 *et seq.* (the “Stafford Act”), as follows:

I have determined that the damage in certain areas of the Commonwealth of Kentucky resulting from severe storms, straight-line winds, flooding, and tornadoes

beginning on December 10, 2021, and continuing, is of sufficient severity and magnitude to warrant a major disaster declaration under the Robert T. Stafford Disaster Relief and Emergency Assistance Act, 42 U.S.C. 5121 *et seq.* (the “Stafford Act”). Therefore, I declare that such a major disaster exists in the Commonwealth of Kentucky.

In order to provide Federal assistance, you are hereby authorized to allocate from funds available for these purposes such amounts as you find necessary for Federal disaster assistance and administrative expenses.

You are authorized to provide Individual Assistance and assistance for debris removal and emergency protective measures (Categories A and B), including direct Federal assistance, under the Public Assistance program in the designated areas, Hazard Mitigation throughout the Commonwealth, and any other forms of assistance under the Stafford Act that you deem appropriate subject to completion of Preliminary Damage Assessments (PDAs).

Consistent with the requirement that Federal assistance be supplemental, any Federal funds provided under the Stafford Act for Public Assistance, Hazard Mitigation, and Other Needs Assistance under section 408 will be limited to 75 percent of the total eligible costs.

Further, you are authorized to make changes to this declaration for the approved assistance to the extent allowable under the Stafford Act.

The time period prescribed for the implementation of section 310(a), Priority to Certain Applications for Public Facility and Public Housing Assistance, 42 U.S.C. 5153, shall be for a period not to exceed six months after the date of this declaration.

The Federal Emergency Management Agency (FEMA) hereby gives notice that pursuant to the authority vested in the Administrator, under Executive Order 12148, as amended, John Brogan, of FEMA is appointed to act as the Federal Coordinating Officer for this major disaster.

The following areas of the Commonwealth of Kentucky have been designated as adversely affected by this major disaster:

Caldwell, Fulton, Graves, Hopkins, Marshall, Muhlenberg, Taylor, and Warren Counties for Individual Assistance.

Caldwell, Fulton, Graves, Hopkins, Marshall, Muhlenberg, Taylor, and Warren Counties for debris removal and emergency protective measures (Categories A and B), including direct federal assistance, under the Public Assistance program.

All areas within the Commonwealth of Kentucky are eligible for assistance under the Hazard Mitigation Grant Program.

The following Catalog of Federal Domestic Assistance Numbers (CFDA) are to be used for reporting and drawing funds: 97.030, Community Disaster Loans; 97.031, Cora Brown Fund; 97.032, Crisis Counseling; 97.033, Disaster Legal Services; 97.034,

Disaster Unemployment Assistance (DUA); 97.046, Fire Management Assistance Grant; 97.048, Disaster Housing Assistance to Individuals and Households In Presidentially Declared Disaster Areas; 97.049, Presidentially Declared Disaster Assistance—Disaster Housing Operations for Individuals and Households; 97.050, Presidentially Declared Disaster Assistance to Individuals and Households—Other Needs; 97.036, Disaster Grants—Public Assistance (Presidentially Declared Disasters); 97.039, Hazard Mitigation Grant.

**Deanne Criswell,**

*Administrator, Federal Emergency Management Agency.*

[FR Doc. 2022–02232 Filed 2–2–22; 8:45 am]

**BILLING CODE 9111–23–P**

## DEPARTMENT OF HOMELAND SECURITY

### Federal Emergency Management Agency

**[Internal Agency Docket No. FEMA–4631–DR; Docket ID FEMA–2021–0001]**

### Confederated Tribes of the Colville Reservation; Major Disaster and Related Determinations

**AGENCY:** Federal Emergency Management Agency, DHS.

**ACTION:** Notice.

**SUMMARY:** This is a notice of the Presidential declaration of a major disaster for the Confederated Tribes of the Colville Reservation (FEMA–4631–DR), dated December 21, 2021, and related determinations.

**DATES:** The declaration was issued December 21, 2021.

**FOR FURTHER INFORMATION CONTACT:** Dean Webster, Office of Response and Recovery, Federal Emergency Management Agency, 500 C Street SW, Washington, DC 20472, (202) 646–2833.

**SUPPLEMENTARY INFORMATION:** Notice is hereby given that, in a letter dated December 21, 2021, the President issued a major disaster declaration under the authority of the Robert T. Stafford Disaster Relief and Emergency Assistance Act, 42 U.S.C. 5121 *et seq.* (the “Stafford Act”), as follows:

I have determined that the damage to the lands associated with the Confederated Tribes of the Colville Reservation resulting from wildfires during the period of July 12 to August 8, 2021, is of sufficient severity and magnitude to warrant a major disaster declaration under the Robert T. Stafford Disaster Relief and Emergency Assistance Act, 42 U.S.C. 5121 *et seq.* (the “Stafford Act”). Therefore, I declare that such a major disaster exists for the Confederated Tribes of the Colville Reservation.

In order to provide Federal assistance, you are hereby authorized to allocate from funds

available for these purposes such amounts as you find necessary for Federal disaster assistance and administrative expenses.

You are authorized to provide Public Assistance and Hazard Mitigation for the Confederated Tribes of the Colville Reservation. Consistent with the requirement that Federal assistance be supplemental, any Federal funds provided under the Stafford Act for Public Assistance and Hazard Mitigation will be limited to 75 percent of the total eligible costs.

Further, you are authorized to make changes to this declaration for the approved assistance to the extent allowable under the Stafford Act.

The Federal Emergency Management Agency (FEMA) hereby gives notice that pursuant to the authority vested in the Administrator, under Executive Order 12148, as amended, Thomas J. Dargan, of FEMA is appointed to act as the Federal Coordinating Officer for this major disaster.

The following areas have been designated as adversely affected by this major disaster:

Confederated Tribes of the Colville Reservation for Public Assistance. The Confederated Tribes of the Colville Reservation is eligible to apply for assistance under the Hazard Mitigation Grant Program.

The following Catalog of Federal Domestic Assistance Numbers (CFDA) are to be used for reporting and drawing funds: 97.030, Community Disaster Loans; 97.031, Cora Brown Fund; 97.032, Crisis Counseling; 97.033, Disaster Legal Services; 97.034, Disaster Unemployment Assistance (DUA); 97.046, Fire Management Assistance Grant; 97.048, Disaster Housing Assistance to Individuals and Households In Presidentially Declared Disaster Areas; 97.049, Presidentially Declared Disaster Assistance—Disaster Housing Operations for Individuals and Households; 97.050, Presidentially Declared Disaster Assistance to Individuals and Households—Other Needs; 97.036, Disaster Grants—Public Assistance (Presidentially Declared Disasters); 97.039, Hazard Mitigation Grant.

**Deanne Criswell,**

*Administrator, Federal Emergency Management Agency.*

[FR Doc. 2022–02245 Filed 2–2–22; 8:45 am]

**BILLING CODE 9111–23–P**

## DEPARTMENT OF HOMELAND SECURITY

### Federal Emergency Management Agency

**[Internal Agency Docket No. FEMA–4498–DR; Docket ID FEMA–2022–0001]**

### Colorado; Amendment No. 8 to Notice of a Major Disaster Declaration

**AGENCY:** Federal Emergency Management Agency, DHS.

**ACTION:** Notice.

**SUMMARY:** This notice amends the notice of a major disaster declaration for the State of Colorado (FEMA-4498-DR), dated March 28, 2020, and related determinations.

**DATES:** This change occurred on January 7, 2022.

**FOR FURTHER INFORMATION CONTACT:** Dean Webster, Office of Response and Recovery, Federal Emergency Management Agency, 500 C Street SW, Washington, DC 20472, (202) 646-2833.

**SUPPLEMENTARY INFORMATION:** The Federal Emergency Management Agency (FEMA) hereby gives notice that pursuant to the authority vested in the Administrator, under Executive Order 12148, as amended, Nancy J. Dragani, of FEMA is appointed to act as the Federal Coordinating Officer for this disaster.

This action terminates the appointment of Tammy L. Littrell as Federal Coordinating Officer for this disaster.

The following Catalog of Federal Domestic Assistance Numbers (CFDA) are to be used for reporting and drawing funds: 97.030, Community Disaster Loans; 97.031, Cora Brown Fund; 97.032, Crisis Counseling; 97.033, Disaster Legal Services; 97.034, Disaster Unemployment Assistance (DUA); 97.046, Fire Management Assistance Grant; 97.048, Disaster Housing Assistance to Individuals and Households In Presidentially Declared Disaster Areas; 97.049, Presidentially Declared Disaster Assistance—Disaster Housing Operations for Individuals and Households; 97.050, Presidentially Declared Disaster Assistance to Individuals and Households—Other Needs; 97.036, Disaster Grants—Public Assistance (Presidentially Declared Disasters); 97.039, Hazard Mitigation Grant.

**Deanne Criswell,**

*Administrator, Federal Emergency Management Agency.*

[FR Doc. 2022-02254 Filed 2-2-22; 8:45 am]

**BILLING CODE 9111-23-P**

**DEPARTMENT OF HOMELAND SECURITY**

[Docket ID FEMA-2014-0022]

**Technical Mapping Advisory Council; Meeting**

**AGENCY:** Federal Emergency Management Agency, Department of Homeland Security.

**ACTION:** Notice of Federal advisory committee meeting.

**SUMMARY:** The Federal Emergency Management Agency (FEMA) Technical Mapping Advisory Council (TMAC) will hold a virtual meeting on Wednesday,

February 23, 2022, and Thursday, February 24, 2022. The meeting will be open to the public via a Microsoft Teams Video Communications link.

**DATES:** The TMAC will meet on Wednesday, February 23, 2022, and Thursday, February 24, 2022 from 10 a.m. to 2 p.m. Eastern Standard Time (EST). Please note that the meeting will close early if the TMAC has completed its business.

**ADDRESSES:** The meeting will be held virtually using the following Microsoft Teams Video Communications link (<https://bit.ly/3eQykKO>). Members of the public who wish to attend the virtual meeting must register in advance by sending an email to [FEMA-TMAC@fema.dhs.gov](mailto:FEMA-TMAC@fema.dhs.gov) (Attention: Brian Koper) by 5 p.m. EST on Monday, February 21, 2022. For information on services for individuals with disabilities or to request special assistance at the meeting, contact the person listed in the **FOR FURTHER INFORMATION CONTACT** caption below as soon as possible.

To facilitate public participation, members of the public are invited to provide written comments on the issues to be considered by the TMAC, as listed in the **SUPPLEMENTARY INFORMATION** caption below. Associated meeting materials will be available at the TMAC website (<https://www.fema.gov/flood-maps/guidance-partners/technical-mapping-advisory-council>) for review by Wednesday, February 16, 2022. The draft 2021 TMAC Annual Report will be available for review by Wednesday, February 16, 2022. To receive a copy, please send the request to: [FEMA-TMAC@fema.dhs.gov](mailto:FEMA-TMAC@fema.dhs.gov) (Attn: Brian Koper). Written comments to be considered by the committee at the time of the meeting must be submitted and received by Monday, February 21, 2022, identified by Docket ID FEMA-2014-0022, and be submitted by one of the following methods:

- *Federal eRulemaking Portal:* <http://www.regulations.gov>. Follow the instructions for submitting comments.
- *Email:* Address the email to [FEMA-TMAC@fema.dhs.gov](mailto:FEMA-TMAC@fema.dhs.gov). Include the docket number in the subject line of the message. Include name and contact information in the body of the email please.

*Instructions:* All submissions received must include the words “Federal Emergency Management Agency” and the docket number for this action. Comments received will be posted without alteration at <http://www.regulations.gov>, including any personal information provided.

*Docket:* For docket access to read background documents or comments

received by the TMAC, go to <http://www.regulations.gov> and search for the Docket ID FEMA-2014-0022.

A public comment period will be held on Wednesday, February 23, 2022, from 11:30 a.m. to 12 p.m. ET and Thursday, February 24, 2022, from 11:30 a.m. to 12 p.m. ET. The public comment period will not exceed 30 minutes. Please note that the public comment period may end before the time indicated, following the last call for comments. Contact the individual listed below to register as a speaker by close of business on Monday, February 21, 2022.

**FOR FURTHER INFORMATION CONTACT:** Brian Koper, Designated Federal Officer for the TMAC, FEMA, 400 C Street SW, Washington, DC 20024, telephone 202-646-3085, and email [brian.koper@fema.dhs.gov](mailto:brian.koper@fema.dhs.gov). The TMAC website is: <https://www.fema.gov/flood-maps/guidance-partners/technical-mapping-advisory-council>.

**SUPPLEMENTARY INFORMATION:** Notice of this meeting is given under the *Federal Advisory Committee Act*, 5 U.S.C. App. (Pub. L. 92-463).

In accordance with the *Biggert-Waters Flood Insurance Reform Act of 2012*, the TMAC makes recommendations to the FEMA Administrator on: (1) How to improve, in a cost-effective manner, the (a) accuracy, general quality, ease of use, and distribution and dissemination of flood insurance rate maps and risk data; and (b) performance metrics and milestones required to effectively and efficiently map flood risk areas in the United States; (2) mapping standards and guidelines for (a) flood insurance rate maps, and (b) data accuracy, data quality, data currency, and data eligibility; (3) how to maintain, on an ongoing basis, flood insurance rate maps and flood risk identification; (4) procedures for delegating mapping activities to State and local mapping partners; and (5) (a) methods for improving interagency and intergovernmental coordination on flood mapping and flood risk determination, and (b) a funding strategy to leverage and coordinate budgets and expenditures across Federal agencies. Furthermore, the TMAC is required to submit an annual report to the FEMA Administrator that contains: (1) A description of the activities of the Council; (2) an evaluation of the status and performance of flood insurance rate maps and mapping activities to revise and update Flood Insurance Rate Maps; and (3) a summary of recommendations made by the Council to the FEMA Administrator.

*Agenda:* The purpose of this meeting is for the TMAC members to discuss and

vote on the content of the 2021 TMAC Annual Report. Any related materials will be posted to the FEMA TMAC site prior to the meeting to provide the public an opportunity to review the materials. The full agenda and related meeting materials will be posted for review by Wednesday, February 16, 2022, at <https://www.fema.gov/flood-maps/guidance-partners/technical-mapping-advisory-council>.

**Michael M. Grimm,**

*Assistant Administrator for Risk Management, Federal Emergency Management Agency.*

[FR Doc. 2022-02282 Filed 2-2-22; 8:45 am]

**BILLING CODE 9110-12-P**

## DEPARTMENT OF HOMELAND SECURITY

### Federal Emergency Management Agency

[Internal Agency Docket No. FEMA-4634-DR; Docket ID FEMA-2022-0001]

#### Colorado; Amendment No. 1 to Notice of a Major Disaster Declaration

**AGENCY:** Federal Emergency Management Agency, DHS.

**ACTION:** Notice.

**SUMMARY:** This notice amends the notice of a major disaster declaration for the State of Colorado (FEMA-4634-DR), dated December 31, 2021, and related determinations.

**DATES:** This amendment was issued January 13, 2022.

**FOR FURTHER INFORMATION CONTACT:** Dean Webster, Office of Response and Recovery, Federal Emergency Management Agency, 500 C Street SW, Washington, DC 20472, (202) 646-2833.

**SUPPLEMENTARY INFORMATION:** Notice is hereby given that the incident period for this disaster is closed effective January 7, 2022.

The following Catalog of Federal Domestic Assistance Numbers (CFDA) are to be used for reporting and drawing funds: 97.030, Community Disaster Loans; 97.031, Cora Brown Fund; 97.032, Crisis Counseling; 97.033, Disaster Legal Services; 97.034, Disaster Unemployment Assistance (DUA); 97.046, Fire Management Assistance Grant; 97.048, Disaster Housing Assistance to Individuals and Households In Presidentially Declared Disaster Areas; 97.049, Presidentially Declared Disaster Assistance—Disaster Housing Operations for Individuals and Households; 97.050, Presidentially Declared Disaster Assistance to Individuals and Households—Other Needs; 97.036, Disaster Grants—Public Assistance

(Presidentially Declared Disasters); 97.039, Hazard Mitigation Grant.

**Deanne Criswell,**

*Administrator, Federal Emergency Management Agency.*

[FR Doc. 2022-02249 Filed 2-2-22; 8:45 am]

**BILLING CODE 9111-23-P**

## DEPARTMENT OF HOMELAND SECURITY

### Federal Emergency Management Agency

[Internal Agency Docket No. FEMA-4619-DR; Docket ID FEMA-2021-0001]

#### California; Amendment No. 2 to Notice of a Major Disaster Declaration

**AGENCY:** Federal Emergency Management Agency, DHS.

**ACTION:** Notice.

**SUMMARY:** This notice amends the notice of a major disaster for the State of California (FEMA-4619-DR), dated September 12, 2021, and related determinations.

**DATES:** The amendment was issued December 14, 2021.

**FOR FURTHER INFORMATION CONTACT:** Dean Webster, Office of Response and Recovery, Federal Emergency Management Agency, 500 C Street SW, Washington, DC 20472, (202) 646-2833.

**SUPPLEMENTARY INFORMATION:** Notice is hereby given that the incident for this declared disaster has been changed to wildfires to include the Cache Fire.

The following Catalog of Federal Domestic Assistance Numbers (CFDA) are to be used for reporting and drawing funds: 97.030, Community Disaster Loans; 97.031, Cora Brown Fund; 97.032, Crisis Counseling; 97.033, Disaster Legal Services; 97.034, Disaster Unemployment Assistance (DUA); 97.046, Fire Management Assistance Grant; 97.048, Disaster Housing Assistance to Individuals and Households In Presidentially Declared Disaster Areas; 97.049, Presidentially Declared Disaster Assistance—Disaster Housing Operations for Individuals and Households; 97.050, Presidentially Declared Disaster Assistance to Individuals and Households—Other Needs; 97.036, Disaster Grants—Public Assistance (Presidentially Declared Disasters); 97.039, Hazard Mitigation Grant.

**Deanne Criswell,**

*Administrator, Federal Emergency Management Agency.*

[FR Doc. 2022-02264 Filed 2-2-22; 8:45 am]

**BILLING CODE 9111-23-P**

## DEPARTMENT OF HOMELAND SECURITY

### Federal Emergency Management Agency

[Internal Agency Docket No. FEMA-4568-DR; Docket ID FEMA-2022-0001]

#### North Carolina; Amendment No. 2 to Notice of a Major Disaster Declaration

**AGENCY:** Federal Emergency Management Agency, DHS.

**ACTION:** Notice.

**SUMMARY:** This notice amends the notice of a major disaster declaration for the State of North Carolina (FEMA-4568-DR), dated October 14, 2020, and related determinations.

**DATES:** This change occurred on January 18, 2022.

**FOR FURTHER INFORMATION CONTACT:** Dean Webster, Office of Response and Recovery, Federal Emergency Management Agency, 500 C Street SW, Washington, DC 20472, (202) 646-2833.

**SUPPLEMENTARY INFORMATION:** The Federal Emergency Management Agency (FEMA) hereby gives notice that pursuant to the authority vested in the Administrator, under Executive Order 12148, as amended, Kevin A. Wallace, of FEMA is appointed to act as the Federal Coordinating Officer for this disaster.

This action terminates the appointment of Myra M. Shird as Federal Coordinating Officer for this disaster.

The following Catalog of Federal Domestic Assistance Numbers (CFDA) are to be used for reporting and drawing funds: 97.030, Community Disaster Loans; 97.031, Cora Brown Fund; 97.032, Crisis Counseling; 97.033, Disaster Legal Services; 97.034, Disaster Unemployment Assistance (DUA); 97.046, Fire Management Assistance Grant; 97.048, Disaster Housing Assistance to Individuals and Households In Presidentially Declared Disaster Areas; 97.049, Presidentially Declared Disaster Assistance—Disaster Housing Operations for Individuals and Households; 97.050, Presidentially Declared Disaster Assistance to Individuals and Households—Other Needs; 97.036, Disaster Grants—Public Assistance (Presidentially Declared Disasters); 97.039, Hazard Mitigation Grant.

**Deanne Criswell,**

*Administrator, Federal Emergency Management Agency.*

[FR Doc. 2022-02242 Filed 2-2-22; 8:45 am]

**BILLING CODE 9111-23-P**

**DEPARTMENT OF HOMELAND SECURITY****Federal Emergency Management Agency**

[Internal Agency Docket No. FEMA-4585-DR; Docket ID FEMA-2022-0001]

**Alaska; Amendment No. 2 to Notice of a Major Disaster Declaration****AGENCY:** Federal Emergency Management Agency, DHS.**ACTION:** Notice.**SUMMARY:** This notice amends the notice of a major disaster declaration for the State of Alaska (FEMA-4585-DR), dated February 17, 2021, and related determinations.**DATES:** This change occurred on January 11, 2022.**FOR FURTHER INFORMATION CONTACT:** Dean Webster, Office of Response and Recovery, Federal Emergency Management Agency, 500 C Street SW, Washington, DC 20472, (202) 646-2833.**SUPPLEMENTARY INFORMATION:** The Federal Emergency Management Agency (FEMA) hereby gives notice that pursuant to the authority vested in the Administrator, under Executive Order 12148, as amended, Thomas J. Dargan, of FEMA is appointed to act as the Federal Coordinating Officer for this disaster.

This action terminates the appointment of Toney L. Raines as Federal Coordinating Officer for this disaster.

The following Catalog of Federal Domestic Assistance Numbers (CFDA) are to be used for reporting and drawing funds: 97.030, Community Disaster Loans; 97.031, Cora Brown Fund; 97.032, Crisis Counseling; 97.033, Disaster Legal Services; 97.034, Disaster Unemployment Assistance (DUA); 97.046, Fire Management Assistance Grant; 97.048, Disaster Housing Assistance to Individuals and Households In Presidentially Declared Disaster Areas; 97.049, Presidentially Declared Disaster Assistance—Disaster Housing Operations for Individuals and Households; 97.050, Presidentially Declared Disaster Assistance to Individuals and Households—Other Needs; 97.036, Disaster Grants—Public Assistance (Presidentially Declared Disasters); 97.039, Hazard Mitigation Grant.

**Deanne Criswell,***Administrator, Federal Emergency Management Agency.*

[FR Doc. 2022-02243 Filed 2-2-22; 8:45 am]

**BILLING CODE 9111-23-P****DEPARTMENT OF HOMELAND SECURITY****Federal Emergency Management Agency**

[Internal Agency Docket No. FEMA-4465-DR; Docket ID FEMA-2022-0001]

**North Carolina; Amendment No. 4 to Notice of a Major Disaster Declaration****AGENCY:** Federal Emergency Management Agency, DHS.**ACTION:** Notice.**SUMMARY:** This notice amends the notice of a major disaster declaration for the State of North Carolina (FEMA-4465-DR), dated October 4, 2019, and related determinations.**DATES:** This change occurred on January 18, 2022.**FOR FURTHER INFORMATION CONTACT:** Dean Webster, Office of Response and Recovery, Federal Emergency Management Agency, 500 C Street SW, Washington, DC 20472, (202) 646-2833.**SUPPLEMENTARY INFORMATION:** The Federal Emergency Management Agency (FEMA) hereby gives notice that pursuant to the authority vested in the Administrator, under Executive Order 12148, as amended, Kevin A. Wallace, of FEMA is appointed to act as the Federal Coordinating Officer for this disaster.

This action terminates the appointment of Myra M. Shird as Federal Coordinating Officer for this disaster.

The following Catalog of Federal Domestic Assistance Numbers (CFDA) are to be used for reporting and drawing funds: 97.030, Community Disaster Loans; 97.031, Cora Brown Fund; 97.032, Crisis Counseling; 97.033, Disaster Legal Services; 97.034, Disaster Unemployment Assistance (DUA); 97.046, Fire Management Assistance Grant; 97.048, Disaster Housing Assistance to Individuals and Households In Presidentially Declared Disaster Areas; 97.049, Presidentially Declared Disaster Assistance—Disaster Housing Operations for Individuals and Households; 97.050, Presidentially Declared Disaster Assistance to Individuals and Households—Other Needs; 97.036, Disaster Grants—Public Assistance (Presidentially Declared Disasters); 97.039, Hazard Mitigation Grant.

**Deanne Criswell,***Administrator, Federal Emergency Management Agency.*

[FR Doc. 2022-02253 Filed 2-2-22; 8:45 am]

**BILLING CODE 9111-23-P****DEPARTMENT OF HOMELAND SECURITY****Federal Emergency Management Agency**

[Internal Agency Docket No. FEMA-4630-DR; Docket ID FEMA-2021-0001]

**Kentucky; Amendment No. 1 to Notice of a Major Disaster Declaration****AGENCY:** Federal Emergency Management Agency, DHS.**ACTION:** Notice.**SUMMARY:** This notice amends the notice of a major disaster declaration for the Commonwealth of Kentucky (FEMA-4630-DR), dated December 12, 2021, and related determinations.**DATES:** This amendment was issued December 16, 2021.**FOR FURTHER INFORMATION CONTACT:** Dean Webster, Office of Response and Recovery, Federal Emergency Management Agency, 500 C Street SW, Washington, DC 20472, (202) 646-2833.**SUPPLEMENTARY INFORMATION:** The notice of a major disaster declaration for the Commonwealth of Kentucky is hereby amended to include the following areas among those areas determined to have been adversely affected by the event declared a major disaster by the President in his declaration of December 12, 2021.

Christian, Hart, Hickman, Logan, Lyon, and Ohio Counties for Individual Assistance.

Christian, Hart, Hickman, Logan, Lyon, and Ohio Counties for debris removal and emergency protective measures [Categories A and B], including direct federal assistance, under the Public Assistance program.

The following Catalog of Federal Domestic Assistance Numbers (CFDA) are to be used for reporting and drawing funds: 97.030, Community Disaster Loans; 97.031, Cora Brown Fund; 97.032, Crisis Counseling; 97.033, Disaster Legal Services; 97.034, Disaster Unemployment Assistance (DUA); 97.046, Fire Management Assistance Grant; 97.048, Disaster Housing Assistance to Individuals and Households In Presidentially Declared Disaster Areas; 97.049, Presidentially Declared Disaster Assistance—Disaster Housing Operations for Individuals and Households; 97.050, Presidentially Declared Disaster Assistance to Individuals and Households—Other Needs; 97.036, Disaster Grants—Public Assistance (Presidentially Declared Disasters); 97.039, Hazard Mitigation Grant.

**Deanne Criswell,***Administrator, Federal Emergency Management Agency.*

[FR Doc. 2022-02233 Filed 2-2-22; 8:45 am]

**BILLING CODE 9111-23-P**



**DEPARTMENT OF HOMELAND SECURITY****Federal Emergency Management Agency**

[Internal Agency Docket No. FEMA-4617-DR; Docket ID FEMA-2022-0001]

**North Carolina; Amendment No. 2 to Notice of a Major Disaster Declaration**

**AGENCY:** Federal Emergency Management Agency, DHS.

**ACTION:** Notice.

**SUMMARY:** This notice amends the notice of a major disaster declaration for State of North Carolina (FEMA-4617-DR), dated September 8, 2021, and related determinations.

**DATES:** This change occurred on January 7, 2022.

**FOR FURTHER INFORMATION CONTACT:**

Dean Webster, Office of Response and Recovery, Federal Emergency Management Agency, 500 C Street SW, Washington, DC 20472, (202) 646-2833.

**SUPPLEMENTARY INFORMATION:** The Federal Emergency Management Agency (FEMA) hereby gives notice that pursuant to the authority vested in the Administrator, under Executive Order 12148, as amended, Kevin A. Wallace, of FEMA is appointed to act as the Federal Coordinating Officer for this disaster.

This action terminates the appointment of John F. Boyle as Federal Coordinating Officer for this disaster.

The following Catalog of Federal Domestic Assistance Numbers (CFDA) are to be used for reporting and drawing funds: 97.030, Community Disaster Loans; 97.031, Cora Brown Fund; 97.032, Crisis Counseling; 97.033, Disaster Legal Services; 97.034, Disaster Unemployment Assistance (DUA); 97.046, Fire Management Assistance Grant; 97.048, Disaster Housing Assistance to Individuals and Households In Presidentially Declared Disaster Areas; 97.049, Presidentially Declared Disaster Assistance—Disaster Housing Operations for Individuals and Households; 97.050, Presidentially Declared Disaster Assistance to Individuals and Households—Other Needs; 97.036, Disaster Grants—Public Assistance (Presidentially Declared Disasters); 97.039, Hazard Mitigation Grant.

**Deanne Criswell,**

*Administrator, Federal Emergency Management Agency.*

[FR Doc. 2022-02263 Filed 2-2-22; 8:45 am]

**BILLING CODE 9111-23-P**

**DEPARTMENT OF HOMELAND SECURITY****Federal Emergency Management Agency**

[Internal Agency Docket No. FEMA-3569-EM; Docket ID FEMA-2022-0001]

**Mississippi; Amendment No. 4 to Notice of an Emergency Declaration**

**AGENCY:** Federal Emergency Management Agency, DHS.

**ACTION:** Notice.

**SUMMARY:** This notice amends the notice of an emergency declaration for the State of Mississippi (FEMA-3569-EM), dated August 28, 2021, and related determinations.

**DATES:** This change occurred on January 14, 2022.

**FOR FURTHER INFORMATION CONTACT:**

Dean Webster, Office of Response and Recovery, Federal Emergency Management Agency, 500 C Street SW, Washington, DC 20472, (202) 646-2833.

**SUPPLEMENTARY INFORMATION:** The Federal Emergency Management Agency (FEMA) hereby gives notice that pursuant to the authority vested in the Administrator, under Executive Order 12148, as amended, James R. Stephenson, of FEMA is appointed to act as the Federal Coordinating Officer for this disaster.

This action terminates the appointment of Brett H. Howard as Federal Coordinating Officer for this disaster.

The following Catalog of Federal Domestic Assistance Numbers (CFDA) are to be used for reporting and drawing funds: 97.030, Community Disaster Loans; 97.031, Cora Brown Fund; 97.032, Crisis Counseling; 97.033, Disaster Legal Services; 97.034, Disaster Unemployment Assistance (DUA); 97.046, Fire Management Assistance Grant; 97.048, Disaster Housing Assistance to Individuals and Households In Presidentially Declared Disaster Areas; 97.049, Presidentially Declared Disaster Assistance—Disaster Housing Operations for Individuals and Households; 97.050, Presidentially Declared Disaster Assistance to Individuals and Households—Other Needs; 97.036, Disaster Grants—Public Assistance (Presidentially Declared Disasters); 97.039, Hazard Mitigation Grant.

**Deanne Criswell,**

*Administrator, Federal Emergency Management Agency.*

[FR Doc. 2022-02224 Filed 2-2-22; 8:45 am]

**BILLING CODE 9111-23-P**

**DEPARTMENT OF HOMELAND SECURITY****Federal Emergency Management Agency**

[Internal Agency Docket No. FEMA-3575-EM; Docket ID FEMA-2021-0001]

**Kentucky; Amendment No. 1 to Notice of an Emergency Declaration**

**AGENCY:** Federal Emergency Management Agency, DHS.

**ACTION:** Notice.

**SUMMARY:** This notice amends the notice of an emergency declaration for the Commonwealth of Kentucky (FEMA-3575-EM), dated December 11, 2021, and related determinations.

**DATES:** This amendment was issued December 12, 2021.

**FOR FURTHER INFORMATION CONTACT:**

Dean Webster, Office of Response and Recovery, Federal Emergency Management Agency, 500 C Street SW, Washington, DC 20472, (202) 646-2833.

**SUPPLEMENTARY INFORMATION:** The notice of an emergency declaration for the Commonwealth of Kentucky is hereby amended to include the following area among those areas determined to have been adversely affected by the event declared an emergency by the President in his declaration of December 11, 2021.

Marshall County for emergency protective measures (Category B), including direct federal assistance under the Public Assistance program.

The following Catalog of Federal Domestic Assistance Numbers (CFDA) are to be used for reporting and drawing funds: 97.030, Community Disaster Loans; 97.031, Cora Brown Fund; 97.032, Crisis Counseling; 97.033, Disaster Legal Services; 97.034, Disaster Unemployment Assistance (DUA); 97.046, Fire Management Assistance Grant; 97.048, Disaster Housing Assistance to Individuals and Households In Presidentially Declared Disaster Areas; 97.049, Presidentially Declared Disaster Assistance—Disaster Housing Operations for Individuals and Households; 97.050, Presidentially Declared Disaster Assistance to Individuals and Households—Other Needs; 97.036, Disaster Grants—Public Assistance (Presidentially Declared Disasters); 97.039, Hazard Mitigation Grant.

**Deanne Criswell,**

*Administrator, Federal Emergency Management Agency.*

[FR Doc. 2022-02226 Filed 2-2-22; 8:45 am]

**BILLING CODE 9111-23-P**

**DEPARTMENT OF HOMELAND SECURITY****Federal Emergency Management Agency**

[Internal Agency Docket No. FEMA-4635-DR; Docket ID FEMA-2022-0001]

**Washington; Major Disaster and Related Determinations****AGENCY:** Federal Emergency Management Agency, DHS.**ACTION:** Notice.**SUMMARY:** This is a notice of the Presidential declaration of a major disaster for the State of Washington (FEMA-4635-DR), dated January 5, 2022, and related determinations.**DATES:** The declaration was issued January 5, 2022.**FOR FURTHER INFORMATION CONTACT:** Dean Webster, Office of Response and Recovery, Federal Emergency Management Agency, 500 C Street SW, Washington, DC 20472, (202) 646-2833.**SUPPLEMENTARY INFORMATION:** Notice is hereby given that, in a letter dated January 5, 2022, the President issued a major disaster declaration under the authority of the Robert T. Stafford Disaster Relief and Emergency Assistance Act, 42 U.S.C. 5121 *et seq.* (the "Stafford Act"), as follows:

I have determined that the damage in certain areas of the State of Washington resulting from flooding and mudslides during the period of November 13 to November 15, 2021, is of sufficient severity and magnitude to warrant a major disaster declaration under the Robert T. Stafford Disaster Relief and Emergency Assistance Act, 42 U.S.C. 5121 *et seq.* (the "Stafford Act"). Therefore, I declare that such a major disaster exists in the State of Washington.

In order to provide Federal assistance, you are hereby authorized to allocate from funds available for these purposes such amounts as you find necessary for Federal disaster assistance and administrative expenses.

You are authorized to provide Individual Assistance in the designated areas and Hazard Mitigation throughout the State. Consistent with the requirement that Federal assistance be supplemental, any Federal funds provided under the Stafford Act for Hazard Mitigation and Other Needs Assistance under section 408 will be limited to 75 percent of the total eligible costs.

Further, you are authorized to make changes to this declaration for the approved assistance to the extent allowable under the Stafford Act.

The time period prescribed for the implementation of section 310(a), Priority to Certain Applications for Public Facility and Public Housing Assistance, 42 U.S.C. 5153, shall be for a period not to exceed six months after the date of this declaration.

The Federal Emergency Management Agency (FEMA) hereby gives notice that pursuant to the authority vested in the Administrator, under Executive Order 12148, as amended, Toney L. Raines, of FEMA is appointed to act as the Federal Coordinating Officer for this major disaster.

The following areas of the State of Washington have been designated as adversely affected by this major disaster:

Clallam, Skagit, and Whatcom Counties and the Lummi Nation, Nooksack Indian Tribe, and Quileute Tribe for Individual Assistance.

All areas within the State of Washington are eligible for assistance under the Hazard Mitigation Grant Program.

The following Catalog of Federal Domestic Assistance Numbers (CFDA) are to be used for reporting and drawing funds: 97.030, Community Disaster Loans; 97.031, Cora Brown Fund; 97.032, Crisis Counseling; 97.033, Disaster Legal Services; 97.034, Disaster Unemployment Assistance (DUA); 97.046, Fire Management Assistance Grant; 97.048, Disaster Housing Assistance to Individuals and Households In Presidentially Declared Disaster Areas; 97.049, Presidentially Declared Disaster Assistance—Disaster Housing Operations for Individuals and Households; 97.050, Presidentially Declared Disaster Assistance to Individuals and Households—Other Needs; 97.036, Disaster Grants—Public Assistance (Presidentially Declared Disasters); 97.039, Hazard Mitigation Grant.

**Deanne Criswell,***Administrator, Federal Emergency Management Agency.*

[FR Doc. 2022-02250 Filed 2-2-22; 8:45 am]

**BILLING CODE 9111-23-P****DEPARTMENT OF HOMELAND SECURITY****Federal Emergency Management Agency**

[Internal Agency Docket No. FEMA-4630-DR; Docket ID FEMA-2022-0001]

**Kentucky; Amendment No. 6 to Notice of a Major Disaster Declaration****AGENCY:** Federal Emergency Management Agency, DHS.**ACTION:** Notice.**SUMMARY:** This notice amends the notice of a major disaster declaration for the Commonwealth of Kentucky (FEMA-4630-DR), dated December 12, 2021, and related determinations.**DATES:** This amendment was issued January 6, 2022.**FOR FURTHER INFORMATION CONTACT:** Dean Webster, Office of Response and Recovery, Federal Emergency Management Agency, 500 C Street SW, Washington, DC 20472, (202) 646-2833.

**SUPPLEMENTARY INFORMATION:** The notice of a major disaster declaration for the Commonwealth of Kentucky is hereby amended to include permanent work under the Public Assistance program for those areas determined to have been adversely affected by the event declared a major disaster by the President in his declaration of December 12, 2021.

Caldwell, Christian, Fulton, Graves, Hart, Hickman, Hopkins, Logan, Lyon, Marion, Marshall, Muhlenberg, Ohio, Taylor, and Warren Counties for permanent work [Categories C-G] (already designated for Individual Assistance and assistance for debris removal and emergency protective measures [Categories A and B], including direct federal assistance, under the Public Assistance program).

Breckinridge, Bullitt, Grayson, Meade, Shelby, and Spencer Counties for emergency protective measures (Category B), including direct federal assistance, under the Public Assistance program.

Todd County for Public Assistance.

The following Catalog of Federal Domestic Assistance Numbers (CFDA) are to be used for reporting and drawing funds: 97.030, Community Disaster Loans; 97.031, Cora Brown Fund; 97.032, Crisis Counseling; 97.033, Disaster Legal Services; 97.034, Disaster Unemployment Assistance (DUA); 97.046, Fire Management Assistance Grant; 97.048, Disaster Housing Assistance to Individuals and Households In Presidentially Declared Disaster Areas; 97.049, Presidentially Declared Disaster Assistance—Disaster Housing Operations for Individuals and Households; 97.050, Presidentially Declared Disaster Assistance to Individuals and Households—Other Needs; 97.036, Disaster Grants—Public Assistance (Presidentially Declared Disasters); 97.039, Hazard Mitigation Grant.

**Deanne Criswell,***Administrator, Federal Emergency Management Agency.*

[FR Doc. 2022-02238 Filed 2-2-22; 8:45 am]

**BILLING CODE 9111-23-P****DEPARTMENT OF HOMELAND SECURITY****Federal Emergency Management Agency**

[Internal Agency Docket No. FEMA-3575-EM; Docket ID FEMA-2022-0001]

**Kentucky; Amendment No. 2 to Notice of an Emergency Declaration****AGENCY:** Federal Emergency Management Agency, DHS.**ACTION:** Notice.**SUMMARY:** This notice amends the notice of an emergency declaration for the Commonwealth of Kentucky (FEMA-3575-EM), dated December 11, 2021, and related determinations.

**DATES:** This amendment was issued January 6, 2022.

**FOR FURTHER INFORMATION CONTACT:** Dean Webster, Office of Response and Recovery, Federal Emergency Management Agency, 500 C Street SW, Washington, DC 20472, (202) 646-2833.

**SUPPLEMENTARY INFORMATION:** Notice is hereby given that the incident period for this emergency is closed effective December 11, 2021.

The following Catalog of Federal Domestic Assistance Numbers (CFDA) are to be used for reporting and drawing funds: 97.030, Community Disaster Loans; 97.031, Cora Brown Fund; 97.032, Crisis Counseling; 97.033, Disaster Legal Services; 97.034, Disaster Unemployment Assistance (DUA); 97.046, Fire Management Assistance Grant; 97.048, Disaster Housing Assistance to Individuals and Households In Presidentially Declared Disaster Areas; 97.049, Presidentially Declared Disaster Assistance—Disaster Housing Operations for Individuals and Households; 97.050, Presidentially Declared Disaster Assistance to Individuals and Households—Other Needs; 97.036, Disaster Grants—Public Assistance (Presidentially Declared Disasters); 97.039, Hazard Mitigation Grant.

**Deanne Criswell,**

*Administrator, Federal Emergency Management Agency.*

[FR Doc. 2022-02227 Filed 2-2-22; 8:45 am]

**BILLING CODE 9111-23-P**

## DEPARTMENT OF HOMELAND SECURITY

### Federal Emergency Management Agency

[Internal Agency Docket No. FEMA-4619-DR; Docket ID FEMA-2021-0001]

#### California; Amendment No. 3 to Notice of a Major Disaster Declaration

**AGENCY:** Federal Emergency Management Agency, DHS.

**ACTION:** Notice.

**SUMMARY:** This notice amends the notice of a major disaster declaration for the State of California (FEMA-4619-DR), dated September 12, 2021, and related determinations.

**DATES:** This amendment was issued December 14, 2021.

**FOR FURTHER INFORMATION CONTACT:** Dean Webster, Office of Response and Recovery, Federal Emergency Management Agency, 500 C Street SW, Washington, DC 20472, (202) 646-2833.

**SUPPLEMENTARY INFORMATION:** The notice of a major disaster declaration for the State of California is hereby amended to include the following area among the area determined to have been adversely

affected by the event declared a major disaster by the President in his declaration of September 12, 2021.

Lake County for debris removal and emergency protective measures (Categories A and B) under the Public Assistance program.

The following Catalog of Federal Domestic Assistance Numbers (CFDA) are to be used for reporting and drawing funds: 97.030, Community Disaster Loans; 97.031, Cora Brown Fund; 97.032, Crisis Counseling; 97.033, Disaster Legal Services; 97.034, Disaster Unemployment Assistance (DUA); 97.046, Fire Management Assistance Grant; 97.048, Disaster Housing Assistance to Individuals and Households In Presidentially Declared Disaster Areas; 97.049, Presidentially Declared Disaster Assistance—Disaster Housing Operations for Individuals and Households; 97.050, Presidentially Declared Disaster Assistance to Individuals and Households—Other Needs; 97.036, Disaster Grants—Public Assistance (Presidentially Declared Disasters); 97.039, Hazard Mitigation Grant.

**Deanne Criswell,**

*Administrator, Federal Emergency Management Agency.*

[FR Doc. 2022-02265 Filed 2-2-22; 8:45 am]

**BILLING CODE 9111-23-P**

## DEPARTMENT OF HOMELAND SECURITY

### Federal Emergency Management Agency

[Internal Agency Docket No. FEMA-4630-DR; Docket ID FEMA-2022-0001]

#### Kentucky; Amendment No. 5 to Notice of a Major Disaster Declaration

**AGENCY:** Federal Emergency Management Agency, DHS.

**ACTION:** Notice.

**SUMMARY:** This notice amends the notice of a major disaster declaration for the Commonwealth of Kentucky (FEMA-4630-DR), dated December 12, 2021, and related determinations.

**DATES:** This amendment was issued January 6, 2022.

**FOR FURTHER INFORMATION CONTACT:** Dean Webster, Office of Response and Recovery, Federal Emergency Management Agency, 500 C Street SW, Washington, DC 20472, (202) 646-2833.

**SUPPLEMENTARY INFORMATION:** Notice is hereby given that the incident period for this disaster is closed effective December 11, 2021.

The following Catalog of Federal Domestic Assistance Numbers (CFDA) are to be used for reporting and drawing funds: 97.030, Community Disaster Loans; 97.031, Cora Brown Fund; 97.032, Crisis Counseling; 97.033, Disaster Legal Services; 97.034, Disaster Unemployment Assistance (DUA);

97.046, Fire Management Assistance Grant; 97.048, Disaster Housing Assistance to Individuals and Households In Presidentially Declared Disaster Areas; 97.049, Presidentially Declared Disaster Assistance—Disaster Housing Operations for Individuals and Households; 97.050, Presidentially Declared Disaster Assistance to Individuals and Households—Other Needs; 97.036, Disaster Grants—Public Assistance (Presidentially Declared Disasters); 97.039, Hazard Mitigation Grant.

**Deanne Criswell,**

*Administrator, Federal Emergency Management Agency.*

[FR Doc. 2022-02237 Filed 2-2-22; 8:45 am]

**BILLING CODE 9111-23-P**

## DEPARTMENT OF HOMELAND SECURITY

### Federal Emergency Management Agency

[Internal Agency Docket No. FEMA-4630-DR; Docket ID FEMA-2021-0001]

#### Kentucky; Amendment No. 2 to Notice of a Major Disaster Declaration

**AGENCY:** Federal Emergency Management Agency, DHS.

**ACTION:** Notice.

**SUMMARY:** This notice amends the notice of a major disaster declaration for the Commonwealth of Kentucky (FEMA-4630-DR), dated December 12, 2021, and related determinations.

**DATES:** This amendment was issued December 22, 2021.

**FOR FURTHER INFORMATION CONTACT:** Dean Webster, Office of Response and Recovery, Federal Emergency Management Agency, 500 C Street SW, Washington, DC 20472, (202) 646-2833.

**SUPPLEMENTARY INFORMATION:** The notice of a major disaster declaration for the Commonwealth of Kentucky is hereby amended to include the following area among those areas determined to have been adversely affected by the event declared a major disaster by the President in his declaration of December 12, 2021.

Barren County for Individual Assistance.

Barren County for debris removal and emergency protective measures [Categories A and B], including direct federal assistance, under the Public Assistance program.

The following Catalog of Federal Domestic Assistance Numbers (CFDA) are to be used for reporting and drawing funds: 97.030, Community Disaster Loans; 97.031, Cora Brown Fund; 97.032, Crisis Counseling; 97.033, Disaster Legal Services; 97.034, Disaster Unemployment Assistance (DUA); 97.046, Fire Management Assistance Grant; 97.048, Disaster Housing Assistance to Individuals and Households In Presidentially

Declared Disaster Areas; 97.049, Presidentially Declared Disaster Assistance—Disaster Housing Operations for Individuals and Households; 97.050, Presidentially Declared Disaster Assistance to Individuals and Households—Other Needs; 97.036, Disaster Grants—Public Assistance (Presidentially Declared Disasters); 97.039, Hazard Mitigation Grant.

**Deanne Criswell,**

*Administrator, Federal Emergency Management Agency.*

[FR Doc. 2022–02234 Filed 2–2–22; 8:45 am]

**BILLING CODE 9111–23–P**

## DEPARTMENT OF HOMELAND SECURITY

### Federal Emergency Management Agency

[Internal Agency Docket No. FEMA–4509–DR; Docket ID FEMA–2022–0001]

#### North Dakota; Amendment No. 8 to Notice of a Major Disaster Declaration

**AGENCY:** Federal Emergency Management Agency, DHS.

**ACTION:** Notice.

**SUMMARY:** This notice amends the notice of a major disaster declaration for the State of North Dakota (FEMA–4509–DR), dated April 1, 2020, and related determinations.

**DATES:** This change occurred on January 7, 2022.

**FOR FURTHER INFORMATION CONTACT:** Dean Webster, Office of Response and Recovery, Federal Emergency Management Agency, 500 C Street SW, Washington, DC 20472, (202) 646–2833.

**SUPPLEMENTARY INFORMATION:** The Federal Emergency Management Agency (FEMA) hereby gives notice that pursuant to the authority vested in the Administrator, under Executive Order 12148, as amended, Nancy J. Dragani, of FEMA is appointed to act as the Federal Coordinating Officer for this disaster.

This action terminates the appointment of Tammy L. Littrell as Federal Coordinating Officer for this disaster.

The following Catalog of Federal Domestic Assistance Numbers (CFDA) are to be used for reporting and drawing funds: 97.030, Community Disaster Loans; 97.031, Cora Brown Fund; 97.032, Crisis Counseling; 97.033, Disaster Legal Services; 97.034, Disaster Unemployment Assistance (DUA); 97.046, Fire Management Assistance Grant; 97.048, Disaster Housing Assistance to Individuals and Households In Presidentially Declared Disaster Areas; 97.049, Presidentially Declared Disaster Assistance—Disaster Housing Operations for Individuals and Households; 97.050, Presidentially Declared Disaster Assistance to Individuals

and Households—Other Needs; 97.036, Disaster Grants—Public Assistance (Presidentially Declared Disasters); 97.039, Hazard Mitigation Grant.

**Deanne Criswell,**

*Administrator, Federal Emergency Management Agency.*

[FR Doc. 2022–02256 Filed 2–2–22; 8:45 am]

**BILLING CODE 9111–23–P**

## DEPARTMENT OF HOMELAND SECURITY

### Federal Emergency Management Agency

[Internal Agency Docket No. FEMA–3576–EM; Docket ID FEMA–2021–0001]

#### Tennessee; Emergency and Related Determinations

**AGENCY:** Federal Emergency Management Agency, DHS.

**ACTION:** Notice.

**SUMMARY:** This is a notice of the Presidential declaration of an emergency for the State of Tennessee (FEMA–3576–EM), dated December 13, 2021, and related determinations.

**DATES:** The declaration was issued December 13, 2021.

**FOR FURTHER INFORMATION CONTACT:** Dean Webster, Office of Response and Recovery, Federal Emergency Management Agency, 500 C Street SW, Washington, DC 20472, (202) 646–2833.

**SUPPLEMENTARY INFORMATION:** Notice is hereby given that, in a letter dated December 13, 2021, the President issued an emergency declaration under the authority of the Robert T. Stafford Disaster Relief and Emergency Assistance Act, 42 U.S.C. 5121–5207 (the Stafford Act), as follows:

I have determined that the emergency conditions in certain areas of the State of Tennessee resulting from severe storms, straight-line winds, and tornadoes during the period of December 10 to December 11, 2021, are of sufficient severity and magnitude to warrant an emergency declaration under the Robert T. Stafford Disaster Relief and Emergency Assistance Act, 42 U.S.C. 5121 *et seq.* (“the Stafford Act”). Therefore, I declare that such an emergency exists in the State of Tennessee.

You are authorized to provide appropriate assistance for required emergency measures, authorized under Title V of the Stafford Act, to save lives and to protect property and public health and safety, and to lessen or avert the threat of a catastrophe in the designated areas. Specifically, you are authorized to provide assistance for emergency protective measures (Category B), including direct Federal assistance under the Public Assistance program.

Consistent with the requirement that Federal assistance be supplemental, any

Federal funds provided under the Stafford Act for Public Assistance will be limited to 75 percent of the total eligible costs. In order to provide Federal assistance, you are hereby authorized to allocate from funds available for these purposes such amounts as you find necessary for Federal emergency assistance and administrative expenses.

Further, you are authorized to make changes to this declaration for the approved assistance to the extent allowable under the Stafford Act.

The Federal Emergency Management Agency (FEMA) hereby gives notice that pursuant to the authority vested in the Administrator, Department of Homeland Security, under Executive Order 12148, as amended, Myra M. Shird, of FEMA is appointed to act as the Federal Coordinating Officer for this declared emergency.

The following areas of the State of Tennessee have been designated as adversely affected by this declared emergency:

Cheatham, Decatur, Dickson, Dyer, Gibson, Lake, Obion, Stewart, and Weakley Counties for emergency protective measures (Category B), including direct federal assistance under the Public Assistance program.

The following Catalog of Federal Domestic Assistance Numbers (CFDA) are to be used for reporting and drawing funds: 97.030, Community Disaster Loans; 97.031, Cora Brown Fund; 97.032, Crisis Counseling; 97.033, Disaster Legal Services; 97.034, Disaster Unemployment Assistance (DUA); 97.046, Fire Management Assistance Grant; 97.048, Disaster Housing Assistance to Individuals and Households In Presidentially Declared Disaster Areas; 97.049, Presidentially Declared Disaster Assistance—Disaster Housing Operations for Individuals and Households; 97.050, Presidentially Declared Disaster Assistance to Individuals and Households—Other Needs; 97.036, Disaster Grants—Public Assistance (Presidentially Declared Disasters); 97.039, Hazard Mitigation Grant.

**Deanne Criswell,**

*Administrator, Federal Emergency Management Agency.*

[FR Doc. 2022–02228 Filed 2–2–22; 8:45 am]

**BILLING CODE 9111–23–P**

## DEPARTMENT OF HOMELAND SECURITY

### Federal Emergency Management Agency

[Internal Agency Docket No. FEMA–4636–DR; Docket ID FEMA–2022–0001]

#### Missouri; Major Disaster and Related Determinations

**AGENCY:** Federal Emergency Management Agency, DHS.

**ACTION:** Notice.

**SUMMARY:** This is a notice of the Presidential declaration of a major disaster for the State of Missouri (FEMA-4636-DR), dated January 10, 2022, and related determinations.

**DATES:** The declaration was issued January 10, 2022.

**FOR FURTHER INFORMATION CONTACT:** Dean Webster, Office of Response and Recovery, Federal Emergency Management Agency, 500 C Street SW, Washington, DC 20472, (202) 646-2833.

**SUPPLEMENTARY INFORMATION:** Notice is hereby given that, in a letter dated January 10, 2022, the President issued a major disaster declaration under the authority of the Robert T. Stafford Disaster Relief and Emergency Assistance Act, 42 U.S.C. 5121 *et seq.* (the "Stafford Act"), as follows:

I have determined that the damage in certain areas of the State of Missouri resulting from severe storms, straight-line winds, and tornadoes on December 10, 2021, is of sufficient severity and magnitude to warrant a major disaster declaration under the Robert T. Stafford Disaster Relief and Emergency Assistance Act, 42 U.S.C. 5121 *et seq.* (the "Stafford Act"). Therefore, I declare that such a major disaster exists in the State of Missouri.

In order to provide Federal assistance, you are hereby authorized to allocate from funds available for these purposes such amounts as you find necessary for Federal disaster assistance and administrative expenses.

You are authorized to provide Public Assistance in the designated areas and Hazard Mitigation throughout the State. Consistent with the requirement that Federal assistance be supplemental, any Federal funds provided under the Stafford Act for Public Assistance and Hazard Mitigation will be limited to 75 percent of the total eligible costs.

Further, you are authorized to make changes to this declaration for the approved assistance to the extent allowable under the Stafford Act.

The Federal Emergency Management Agency (FEMA) hereby gives notice that pursuant to the authority vested in the Administrator, under Executive Order 12148, as amended, DuWayne Tewes, of FEMA is appointed to act as the Federal Coordinating Officer for this major disaster.

The following areas of the State of Missouri have been designated as adversely affected by this major disaster:

Bollinger, Dunklin, Iron, Madison, Pemiscot, Reynolds, and Wayne Counties for Public Assistance.

All areas within the State of Missouri are eligible for assistance under the Hazard Mitigation Grant Program.

The following Catalog of Federal Domestic Assistance Numbers (CFDA) are to be used for reporting and drawing funds: 97.030, Community Disaster Loans; 97.031, Cora Brown Fund; 97.032, Crisis Counseling;

97.033, Disaster Legal Services; 97.034, Disaster Unemployment Assistance (DUA); 97.046, Fire Management Assistance Grant; 97.048, Disaster Housing Assistance to Individuals and Households In Presidentially Declared Disaster Areas; 97.049, Presidentially Declared Disaster Assistance—Disaster Housing Operations for Individuals and Households; 97.050, Presidentially Declared Disaster Assistance to Individuals and Households—Other Needs; 97.036, Disaster Grants—Public Assistance (Presidentially Declared Disasters); 97.039, Hazard Mitigation Grant.

**Deanne Criswell,**

*Administrator, Federal Emergency Management Agency.*

[FR Doc. 2022-02251 Filed 2-2-22; 8:45 am]

**BILLING CODE 9111-23-P**

## DEPARTMENT OF HOMELAND SECURITY

### Federal Emergency Management Agency

[Internal Agency Docket No. FEMA-4632-DR; Docket ID FEMA-2021-0001]

#### Alabama; Amendment No. 1 to Notice of a Major Disaster Declaration

**AGENCY:** Federal Emergency Management Agency, DHS.

**ACTION:** Notice.

**SUMMARY:** This notice amends the notice of a major disaster declaration for State of Alabama (FEMA-4632-DR), dated December 21, 2021, and related determinations.

**DATES:** This change occurred on December 21, 2021.

**FOR FURTHER INFORMATION CONTACT:** Dean Webster, Office of Response and Recovery, Federal Emergency Management Agency, 500 C Street SW, Washington, DC 20472, (202) 646-2833.

**SUPPLEMENTARY INFORMATION:** The Federal Emergency Management Agency (FEMA) hereby gives notice that pursuant to the authority vested in the Administrator, under Executive Order 12148, as amended, Allan Jarvis, of FEMA is appointed to act as the Federal Coordinating Officer for this disaster.

This action terminates the appointment of James R. Stephenson as Federal Coordinating Officer for this disaster.

The following Catalog of Federal Domestic Assistance Numbers (CFDA) are to be used for reporting and drawing funds: 97.030, Community Disaster Loans; 97.031, Cora Brown Fund; 97.032, Crisis Counseling; 97.033, Disaster Legal Services; 97.034, Disaster Unemployment Assistance (DUA); 97.046, Fire Management Assistance Grant; 97.048, Disaster Housing Assistance to Individuals and Households In Presidentially

Declared Disaster Areas; 97.049, Presidentially Declared Disaster Assistance—Disaster Housing Operations for Individuals and Households; 97.050, Presidentially Declared Disaster Assistance to Individuals and Households—Other Needs; 97.036, Disaster Grants—Public Assistance (Presidentially Declared Disasters); 97.039, Hazard Mitigation Grant.

**Deanne Criswell,**

*Administrator, Federal Emergency Management Agency.*

[FR Doc. 2022-02247 Filed 2-2-22; 8:45 am]

**BILLING CODE 9111-23-P**

## DEPARTMENT OF HOMELAND SECURITY

### Federal Emergency Management Agency

[Internal Agency Docket No. FEMA-4630-DR; Docket ID FEMA-2021-0001]

#### Kentucky; Amendment No. 4 to Notice of a Major Disaster Declaration

**AGENCY:** Federal Emergency Management Agency, DHS.

**ACTION:** Notice.

**SUMMARY:** This notice amends the notice of a major disaster for the Commonwealth of Kentucky (FEMA-4630-DR), dated December 12, 2021, and related determinations.

**DATES:** This amendment was issued December 15, 2021.

**FOR FURTHER INFORMATION CONTACT:** Dean Webster, Office of Response and Recovery, Federal Emergency Management Agency, 500 C Street SW, Washington, DC 20472, (202) 646-2833.

**SUPPLEMENTARY INFORMATION:** Notice is hereby given that, in a letter dated December 15, 2021, the President amended the cost-sharing arrangements regarding Federal funds provided under the authority of the Robert T. Stafford Disaster Relief and Emergency Assistance Act, 42 U.S.C. 5121 *et seq.* (the "Stafford Act"), in a letter to Deanne Criswell, Administrator, Federal Emergency Management Agency, Department of Homeland Security, under Executive Order 12148, as follows:

I have determined that the damage in certain areas of the Commonwealth of Kentucky resulting from severe storms, straight-line winds, flooding, and tornadoes beginning on December 10, 2021, and continuing, is of sufficient severity and magnitude that special cost sharing arrangements are warranted regarding Federal funds provided under the Robert T. Stafford Disaster Relief and Emergency Assistance Act, 42 U.S.C. 5121 *et seq.* (the "Stafford Act").

Therefore, I amend my declaration of December 12, 2021, to authorize Federal funds for debris removal and emergency protective measures, including direct Federal assistance, at 100 percent of the total eligible costs for a 30-day period from the date of declaration.

This adjustment to commonwealth and local cost sharing applies only to Public Assistance costs and direct Federal assistance eligible for such adjustments under the law. The Robert T. Stafford Disaster Relief and Emergency Assistance Act specifically prohibits a similar adjustment for funds provided for Other Needs Assistance (Section 408) and the Hazard Mitigation Grant Program (Section 404). These funds will continue to be reimbursed at 75 percent of total eligible costs.

(The following Catalog of Federal Domestic Assistance Numbers (CFDA) are to be used for reporting and drawing funds: 97.030, Community Disaster Loans; 97.031, Cora Brown Fund; 97.032, Crisis Counseling; 97.033, Disaster Legal Services; 97.034, Disaster Unemployment Assistance (DUA); 97.046, Fire Management Assistance Grant; 97.048, Disaster Housing Assistance to Individuals and Households In Presidentially Declared Disaster Areas; 97.049, Presidentially Declared Disaster Assistance—Disaster Housing Operations for Individuals and Households; 97.050, Presidentially Declared Disaster Assistance to Individuals and Households—Other Needs; 97.036, Disaster Grants—Public Assistance (Presidentially Declared Disasters); 97.039, Hazard Mitigation Grant).

**Deanne Criswell,**

*Administrator, Federal Emergency Management Agency.*

[FR Doc. 2022-02236 Filed 2-2-22; 8:45 am]

**BILLING CODE 9111-23-P**

## DEPARTMENT OF HOMELAND SECURITY

### Federal Emergency Management Agency

[Internal Agency Docket No. FEMA-3577-EM; Docket ID FEMA-2021-0001]

#### Illinois; Emergency and Related Determinations

**AGENCY:** Federal Emergency Management Agency, DHS.

**ACTION:** Notice.

**SUMMARY:** This is a notice of the Presidential declaration of an emergency for the State of Illinois (FEMA-3577-EM), dated December 13, 2021, and related determinations.

**DATES:** The declaration was issued December 13, 2021.

**FOR FURTHER INFORMATION CONTACT:** Dean Webster, Office of Response and Recovery, Federal Emergency Management Agency, 500 C Street SW, Washington, DC 20472, (202) 646-2833.

**SUPPLEMENTARY INFORMATION:** Notice is hereby given that, in a letter dated December 13, 2021, the President issued an emergency declaration under the authority of the Robert T. Stafford Disaster Relief and Emergency Assistance Act, 42 U.S.C. 5121-5207 (the Stafford Act), as follows:

I have determined that the emergency conditions in certain areas of the State of Illinois resulting from severe storms, straight-line winds, and tornadoes on December 10, 2021, are of sufficient severity and magnitude to warrant an emergency declaration under the Robert T. Stafford Disaster Relief and Emergency Assistance Act, 42 U.S.C. 5121 *et seq.* (“the Stafford Act”). Therefore, I declare that such an emergency exists in the State of Illinois.

You are authorized to provide appropriate assistance for required emergency measures, authorized under Title V of the Stafford Act, to save lives and to protect property and public health and safety, and to lessen or avert the threat of a catastrophe in the designated areas. Specifically, you are authorized to provide assistance for emergency protective measures (Category B), including direct Federal assistance under the Public Assistance program.

Consistent with the requirement that Federal assistance be supplemental, any Federal funds provided under the Stafford Act for Public Assistance will be limited to 75 percent of the total eligible costs. In order to provide Federal assistance, you are hereby authorized to allocate from funds available for these purposes such amounts as you find necessary for Federal emergency assistance and administrative expenses.

Further, you are authorized to make changes to this declaration for the approved assistance to the extent allowable under the Stafford Act.

The Federal Emergency Management Agency (FEMA) hereby gives notice that pursuant to the authority vested in the Administrator, Department of Homeland Security, under Executive Order 12148, as amended, Brian F. Schiller, of FEMA is appointed to act as the Federal Coordinating Officer for this declared emergency.

The following areas of the State of Illinois have been designated as adversely affected by this declared emergency:

Bond, Cass, Coles, Effingham, Fayette, Jersey, Macoupin, Madison, Montgomery, Morgan, Moultrie, Pike, and Shelby Counties for emergency protective measures (Category B), including direct federal assistance under the Public Assistance program.

The following Catalog of Federal Domestic Assistance Numbers (CFDA) are to be used for reporting and drawing funds: 97.030, Community Disaster Loans; 97.031, Cora Brown Fund; 97.032, Crisis Counseling; 97.033, Disaster Legal Services; 97.034, Disaster Unemployment Assistance (DUA); 97.046, Fire Management Assistance Grant; 97.048, Disaster Housing Assistance to

Individuals and Households In Presidentially Declared Disaster Areas; 97.049, Presidentially Declared Disaster Assistance—Disaster Housing Operations for Individuals and Households; 97.050, Presidentially Declared Disaster Assistance to Individuals and Households—Other Needs; 97.036, Disaster Grants—Public Assistance (Presidentially Declared Disasters); 97.039, Hazard Mitigation Grant.

**Deanne Criswell,**

*Administrator, Federal Emergency Management Agency.*

[FR Doc. 2022-02229 Filed 2-2-22; 8:45 am]

**BILLING CODE 9111-23-P**

## DEPARTMENT OF HOMELAND SECURITY

### Federal Emergency Management Agency

[Internal Agency Docket No. FEMA-4508-DR; Docket ID FEMA-2022-0001]

#### Montana; Amendment No. 8 to Notice of a Major Disaster Declaration

**AGENCY:** Federal Emergency Management Agency, DHS.

**ACTION:** Notice.

**SUMMARY:** This notice amends the notice of a major disaster declaration for the State of Montana (FEMA-4508-DR), dated March 31, 2020, and related determinations.

**DATES:** This change occurred on January 7, 2022.

**FOR FURTHER INFORMATION CONTACT:**

Dean Webster, Office of Response and Recovery, Federal Emergency Management Agency, 500 C Street SW, Washington, DC 20472, (202) 646-2833.

**SUPPLEMENTARY INFORMATION:** The Federal Emergency Management Agency (FEMA) hereby gives notice that pursuant to the authority vested in the Administrator, under Executive Order 12148, as amended, Nancy J. Dragani, of FEMA is appointed to act as the Federal Coordinating Officer for this disaster.

This action terminates the appointment of Tammy L. Littrell as Federal Coordinating Officer for this disaster.

The following Catalog of Federal Domestic Assistance Numbers (CFDA) are to be used for reporting and drawing funds: 97.030, Community Disaster Loans; 97.031, Cora Brown Fund; 97.032, Crisis Counseling; 97.033, Disaster Legal Services; 97.034, Disaster Unemployment Assistance (DUA); 97.046, Fire Management Assistance Grant; 97.048, Disaster Housing Assistance to Individuals and Households In Presidentially Declared Disaster Areas; 97.049, Presidentially Declared Disaster Assistance—Disaster Housing Operations for Individuals and Households; 97.050, Presidentially

Declared Disaster Assistance to Individuals and Households—Other Needs; 97.036, Disaster Grants—Public Assistance (Presidentially Declared Disasters); 97.039, Hazard Mitigation Grant.

**Deanne Criswell,**

*Administrator, Federal Emergency Management Agency.*

[FR Doc. 2022-02255 Filed 2-2-22; 8:45 am]

**BILLING CODE 9111-23-P**

## DEPARTMENT OF HOMELAND SECURITY

### Federal Emergency Management Agency

[Docket ID FEMA-2021-0026; OMB No. 1660-NW134]

#### Agency Information Collection Activities: Proposed Collection; Comment Request; FEMA Pandemic Personnel Facility Access

**AGENCY:** Federal Emergency Management Agency, Department of Homeland Security.

**ACTION:** 60 Day notice of new collection and request for comments.

**SUMMARY:** The Federal Emergency Management Agency (FEMA), as part of its continuing effort to reduce paperwork and respondent burden, invites the general public to take this opportunity to comment on a new information collection. In accordance with the Paperwork Reduction Act of 1995, this notice seeks comments concerning a new collection. FEMA seeks to collect information from civilians and contractors, including vaccination information and personal information, for access to FEMA facilities.

**DATES:** Comments must be submitted on or before April 4, 2022.

**ADDRESSES:** To avoid duplicate submissions to the docket, please submit comments at [www.regulations.gov](http://www.regulations.gov) under Docket ID FEMA-2021-0026. Follow the instructions for submitting comments.

All submissions received must include the agency name and Docket ID. Regardless of the method used for submitting comments or material, all submissions will be posted, without change, to the Federal eRulemaking Portal at <http://www.regulations.gov>, and will include any personal information you provide. Therefore, submitting this information makes it public. You may wish to read the Privacy and Security Notice that is available via a link on the homepage of [www.regulations.gov](http://www.regulations.gov).

**FOR FURTHER INFORMATION CONTACT:** Stacey Buccigross, Training & Process Improvement Manager for the COVID-19 Task Force, FEMA's Office of the Chief Administrative Officer Environmental, Safety & Health Division, Medial Branch, by telephone at (202) 718-3195 or via email at [Stacey.Buccigross@fema.dhs.gov](mailto:Stacey.Buccigross@fema.dhs.gov). You may contact the Information Management Division for copies of the proposed collection of information at email address: [FEMA-Information-Collections-Management@fema.dhs.gov](mailto:FEMA-Information-Collections-Management@fema.dhs.gov).

**SUPPLEMENTARY INFORMATION:** FEMA is collecting additional information related to non-Federal employees during contact tracing, as authorized by DHS/ALL-047 Records Related to DHS Personnel, Long-Term Trainees, Contractors, Mission Support Individuals, and Visitors During a Declared Public Health Emergency.

This update allows a reporting individual to provide information related to a COVID-19, to impacted individuals and suspected close contact individuals. Additional information that FEMA will now begin to collect include names and phone numbers. Other individual information may be provided that is directly related to the disease or illness (e.g., testing results, symptoms, treatments, source of exposure) and FEMA contact tracers will contact all individuals who may be close contacts to inform them of the potential exposure. At that time, the close contact individual will have the option to provide additional information.

FEMA's Environmental Safety and Health (ESH) Division manages contact tracing within FEMA facilities. Individuals who report to their supervisors a suspicion of COVID-19 related symptoms will have their report tracked via a SharePoint site. Information is provided by individuals using a front-end form housed on the SharePoint site, or through a phone call to a helpline monitored by the Contact Tracing Team. In the case of a report via phone, the individual who received the call will manually enter the data into the SharePoint site. This allows FEMA to track any potential exposure to other individuals and facilities. Additionally, FEMA will use the site to contact the employee and potentially those who may have been exposed.

The SharePoint site allows two levels of permission access. The first is for all individuals with access to the FEMA Enterprise Network. Those individuals will have permission only to the submission form and to view records that they created. The second is for individuals with access to all the

information that has been submitted. This is strictly limited to the FEMA ESH and individuals appointed as contact tracers by ESH.

Reports include COVID-19 symptoms present, presumptive positive, and confirmed positive/negative cases. FEMA will update the report periodically until the individual has been cleared to return to work. Also, an individual can provide FEMA with a date referencing their first medical service received related to COVID-19 and vaccination status. When a report is received, the SharePoint site creates a case ID. This is an auto-generated number that is formulated based on the state the individual reports from and the date of report.

If a report is called into the helpline related to visitors or short-term students at or on buildings, grounds, and properties that are owned, leased, or used by FEMA, the individual that was at a FEMA facility can submit a report of possible COVID-19 related symptoms to the Contact Tracing Team.

#### Collection of Information

*Title:* FEMA Pandemic Personnel Facility Access.

*Type of Information Collection:* New information collection.

*OMB Number:* 1660 NW134.

*FEMA Forms:* FEMA Form FF-119-FY-22-107, Authorized Tracer Entry Form; FEMA Form FF-119-FY-22-108, Authorized Tracer Warning Page; FEMA Form FF-119-FY-22-109, CCMT Sandbox Forms; FEMA Form FF-119-FY-22-110, Contact Tracer Entry Updated Warning Page; FEMA Form FF-119-FY-22-111, DHS Employee Confirm Submission; FEMA Form FF-119-FY-22-112, DHS Employee Warning Page; FEMA Form FF-119-FY-22-113, DHS Entry Form; FEMA Form FF-119-FY-22-114, Entry Update Portal; FEMA Form FF-119-FY-22-115, Facility Manager Confirm Submission; FEMA Form FF-119-FY-22-117, Facility manager Update Form; FEMA Form FF-119-FY-22-118, Facility Manager Update Warning Page; FEMA Form FF-119-FY-22-119, Form A; FEMA Form FF-119-FY-22-120, Form B; FEMA Form FF-119-FY-22-121, Form C; FEMA Form FF-119-FY-22-122, New Entry Portal; FEMA Form FF-119-FY-22-123, Non-DHS Confirm Submission; FEMA Form FF-119-FY-22-124, Non-DHS Entry Form; FEMA Form FF-119-FY-22-125, Non-DHS Warning Page.

*Abstract:* This collection is a collection from civilians and contractors, including vaccination information and personal information, for access to FEMA facility.

*Affected Public:* Individuals or Households; State, local or tribal government.

*Estimated Number of Respondents:* 750.

*Estimated Number of Responses:* 4,000.

*Estimated Total Annual Burden Hours:* 1,063.

*Estimated Total Annual Respondent Cost:* \$41,723.

*Estimated Respondents' Operation and Maintenance Costs:* \$0.

*Estimated Respondents' Capital and Start-Up Costs:* \$0.

*Estimated Total Annual Cost to the Federal Government:* \$210,542.

### Comments

Comments may be submitted as indicated in the **ADDRESSES** caption above.

Comments are solicited to (a) evaluate whether the proposed data collection is necessary for the proper performance of the agency, including whether the information shall have practical utility; (b) evaluate the accuracy of the agency's estimate of the burden of the proposed collection of information, including the validity of the methodology and assumptions used; (c) enhance the quality, utility, and clarity of the information to be collected; and (d) minimize the burden of the collection of information on those who are to respond, including through the use of appropriate automated, electronic, mechanical, or other technological collection techniques or other forms of information technology, *e.g.*, permitting electronic submission of responses.

**Millicent Brown Wilson,**

*Records Management Branch, Team Lead, Office of the Chief Administrative Officer, Mission Support, Federal Emergency Management Agency, Department of Homeland Security.*

[FR Doc. 2022-02223 Filed 2-2-22; 8:45 am]

**BILLING CODE 9111-19-P**

## DEPARTMENT OF HOMELAND SECURITY

### Federal Emergency Management Agency

[Internal Agency Docket No. FEMA-4624-DR; Docket ID FEMA-2021-0001]

#### New Hampshire; Amendment No. 1 to Notice of a Major Disaster Declaration

**AGENCY:** Federal Emergency Management Agency, DHS.

**ACTION:** Notice.

**SUMMARY:** This notice amends the notice of a major disaster for the State of New

Hampshire (FEMA-4624-DR), dated October 4, 2021, and related determinations.

**DATES:** The amendment was issued December 27, 2021.

**FOR FURTHER INFORMATION CONTACT:** Dean Webster, Office of Response and Recovery, Federal Emergency Management Agency, 500 C Street SW, Washington, DC 20472, (202) 646-2833.

**SUPPLEMENTARY INFORMATION:** Notice is hereby given that the incident period for this declared disaster is now July 29, 2021, through and including August 2, 2021.

The following Catalog of Federal Domestic Assistance Numbers (CFDA) are to be used for reporting and drawing funds: 97.030, Community Disaster Loans; 97.031, Cora Brown Fund; 97.032, Crisis Counseling; 97.033, Disaster Legal Services; 97.034, Disaster Unemployment Assistance (DUA); 97.046, Fire Management Assistance Grant; 97.048, Disaster Housing Assistance to Individuals and Households In Presidentially Declared Disaster Areas; 97.049, Presidentially Declared Disaster Assistance—Disaster Housing Operations for Individuals and Households; 97.050, Presidentially Declared Disaster Assistance to Individuals and Households—Other Needs; 97.036, Disaster Grants—Public Assistance (Presidentially Declared Disasters); 97.039, Hazard Mitigation Grant.

**Deanne Criswell,**

*Administrator, Federal Emergency Management Agency.*

[FR Doc. 2022-02230 Filed 2-2-22; 8:45 am]

**BILLING CODE 9111-23-P**

## DEPARTMENT OF HOMELAND SECURITY

### Federal Emergency Management Agency

[Internal Agency Docket No. FEMA-4527-DR; Docket ID FEMA-2022-0001]

#### South Dakota; Amendment No. 8 to Notice of a Major Disaster Declaration

**AGENCY:** Federal Emergency Management Agency, DHS.

**ACTION:** Notice.

**SUMMARY:** This notice amends the notice of a major disaster declaration for the State of South Dakota (FEMA-4527-DR), dated April 5, 2020, and related determinations.

**DATES:** This change occurred on January 7, 2022.

**FOR FURTHER INFORMATION CONTACT:** Dean Webster, Office of Response and Recovery, Federal Emergency Management Agency, 500 C Street SW, Washington, DC 20472, (202) 646-2833.

**SUPPLEMENTARY INFORMATION:** The Federal Emergency Management Agency (FEMA) hereby gives notice that pursuant to the authority vested in the Administrator, under Executive Order 12148, as amended, Nancy J. Dragani, of FEMA is appointed to act as the Federal Coordinating Officer for this disaster.

This action terminates the appointment of Tammy L. Littrell as Federal Coordinating Officer for this disaster.

The following Catalog of Federal Domestic Assistance Numbers (CFDA) are to be used for reporting and drawing funds: 97.030, Community Disaster Loans; 97.031, Cora Brown Fund; 97.032, Crisis Counseling; 97.033, Disaster Legal Services; 97.034, Disaster Unemployment Assistance (DUA); 97.046, Fire Management Assistance Grant; 97.048, Disaster Housing Assistance to Individuals and Households In Presidentially Declared Disaster Areas; 97.049, Presidentially Declared Disaster Assistance—Disaster Housing Operations for Individuals and Households; 97.050, Presidentially Declared Disaster Assistance to Individuals and Households—Other Needs; 97.036, Disaster Grants—Public Assistance (Presidentially Declared Disasters); 97.039, Hazard Mitigation Grant.

**Deanne Criswell,**

*Administrator, Federal Emergency Management Agency.*

[FR Doc. 2022-02240 Filed 2-2-22; 8:45 am]

**BILLING CODE 9111-23-P**

## DEPARTMENT OF HOMELAND SECURITY

### Federal Emergency Management Agency

[Internal Agency Docket No. FEMA-4632-DR; Docket ID FEMA-2021-0001]

#### Alabama; Major Disaster and Related Determinations

**AGENCY:** Federal Emergency Management Agency, DHS.

**ACTION:** Notice.

**SUMMARY:** This is a notice of the Presidential declaration of a major disaster for the State of Alabama (FEMA-4632-DR), dated December 21, 2021, and related determinations.

**DATES:** The declaration was issued December 21, 2021.

**FOR FURTHER INFORMATION CONTACT:** Dean Webster, Office of Response and Recovery, Federal Emergency Management Agency, 500 C Street SW, Washington, DC 20472, (202) 646-2833.

**SUPPLEMENTARY INFORMATION:** Notice is hereby given that, in a letter dated December 21, 2021, the President issued a major disaster declaration under the



authority of the Robert T. Stafford Disaster Relief and Emergency Assistance Act, 42 U.S.C. 5121 *et seq.* (the “Stafford Act”), as follows:

I have determined that the damage in certain areas of the State of Alabama resulting from severe storms and flooding during the period of October 6 to October 7, 2021, is of sufficient severity and magnitude to warrant a major disaster declaration under the Robert T. Stafford Disaster Relief and Emergency Assistance Act, 42 U.S.C. 5121 *et seq.* (the “Stafford Act”). Therefore, I declare that such a major disaster exists in the State of Alabama.

In order to provide Federal assistance, you are hereby authorized to allocate from funds available for these purposes such amounts as you find necessary for Federal disaster assistance and administrative expenses.

You are authorized to provide Individual Assistance in the designated areas and Hazard Mitigation throughout the State. Consistent with the requirement that Federal assistance be supplemental, any Federal funds provided under the Stafford Act for Hazard Mitigation and Other Needs Assistance under section 408 will be limited to 75 percent of the total eligible costs.

Further, you are authorized to make changes to this declaration for the approved assistance to the extent allowable under the Stafford Act.

The time period prescribed for the implementation of section 310(a), Priority to Certain Applications for Public Facility and Public Housing Assistance, 42 U.S.C. 5153, shall be for a period not to exceed six months after the date of this declaration.

The Federal Emergency Management Agency (FEMA) hereby gives notice that pursuant to the authority vested in the Administrator, under Executive Order 12148, as amended, James R. Stephenson, of FEMA is appointed to act as the Federal Coordinating Officer for this major disaster.

The following areas of the State of Alabama have been designated as adversely affected by this major disaster:

Jefferson and Shelby Counties for Individual Assistance.

All areas within the State of Alabama are eligible for assistance under the Hazard Mitigation Grant Program.

The following Catalog of Federal Domestic Assistance Numbers (CFDA) are to be used for reporting and drawing funds: 97.030, Community Disaster Loans; 97.031, Cora Brown Fund; 97.032, Crisis Counseling; 97.033, Disaster Legal Services; 97.034, Disaster Unemployment Assistance (DUA); 97.046, Fire Management Assistance Grant; 97.048, Disaster Housing Assistance to Individuals and Households In Presidentially Declared Disaster Areas; 97.049, Presidentially Declared Disaster Assistance—Disaster Housing Operations for Individuals and Households; 97.050, Presidentially Declared Disaster Assistance to Individuals and Households—Other Needs; 97.036,

Disaster Grants—Public Assistance (Presidentially Declared Disasters); 97.039, Hazard Mitigation Grant.

**Deanne Criswell,**  
*Administrator, Federal Emergency Management Agency.*

[FR Doc. 2022–02246 Filed 2–2–22; 8:45 am]

**BILLING CODE 9111–23–P**

## DEPARTMENT OF HOMELAND SECURITY

### Federal Emergency Management Agency

[Internal Agency Docket No. FEMA–4630–DR; Docket ID FEMA–2021–0001]

#### Kentucky; Amendment No. 3 to Notice of a Major Disaster Declaration

**AGENCY:** Federal Emergency Management Agency, DHS.

**ACTION:** Notice.

**SUMMARY:** This notice amends the notice of a major disaster declaration for the Commonwealth of Kentucky (FEMA–4630–DR), dated December 12, 2021, and related determinations.

**DATES:** This amendment was issued December 24, 2021.

**FOR FURTHER INFORMATION CONTACT:** Dean Webster, Office of Response and Recovery, Federal Emergency Management Agency, 500 C Street SW, Washington, DC 20472, (202) 646–2833.

**SUPPLEMENTARY INFORMATION:** The notice of a major disaster declaration for the Commonwealth of Kentucky is hereby amended to include the following area among those areas determined to have been adversely affected by the event declared a major disaster by the President in his declaration of December 12, 2021.

Marion County for Individual Assistance. Marion County for debris removal and emergency protective measures [Categories A and B], including direct federal assistance, under the Public Assistance program.

The following Catalog of Federal Domestic Assistance Numbers (CFDA) are to be used for reporting and drawing funds: 97.030, Community Disaster Loans; 97.031, Cora Brown Fund; 97.032, Crisis Counseling; 97.033, Disaster Legal Services; 97.034, Disaster Unemployment Assistance (DUA); 97.046, Fire Management Assistance Grant; 97.048, Disaster Housing Assistance to Individuals and Households In Presidentially Declared Disaster Areas; 97.049, Presidentially Declared Disaster Assistance—Disaster Housing Operations for Individuals and Households; 97.050, Presidentially Declared Disaster Assistance to Individuals and Households—Other Needs; 97.036, Disaster Grants—Public Assistance

(Presidentially Declared Disasters); 97.039, Hazard Mitigation Grant.

**Deanne Criswell,**  
*Administrator, Federal Emergency Management Agency.*

[FR Doc. 2022–02235 Filed 2–2–22; 8:45 am]

**BILLING CODE 9111–23–P**

## DEPARTMENT OF HOMELAND SECURITY

### Federal Emergency Management Agency

[Internal Agency Docket No. FEMA–4525–DR; Docket ID FEMA–2022–0001]

#### Utah; Amendment No. 8 to Notice of a Major Disaster Declaration

**AGENCY:** Federal Emergency Management Agency, DHS.

**ACTION:** Notice.

**SUMMARY:** This notice amends the notice of a major disaster declaration for the State of Utah (FEMA–4525–DR), dated April 4, 2020, and related determinations.

**DATES:** This change occurred on January 7, 2021.

**FOR FURTHER INFORMATION CONTACT:** Dean Webster, Office of Response and Recovery, Federal Emergency Management Agency, 500 C Street SW, Washington, DC 20472, (202) 646–2833.

**SUPPLEMENTARY INFORMATION:** The Federal Emergency Management Agency (FEMA) hereby gives notice that pursuant to the authority vested in the Administrator, under Executive Order 12148, as amended, Nancy J. Dragani, of FEMA is appointed to act as the Federal Coordinating Officer for this disaster.

This action terminates the appointment of Tammy L. Littrell as Federal Coordinating Officer for this disaster.

The following Catalog of Federal Domestic Assistance Numbers (CFDA) are to be used for reporting and drawing funds: 97.030, Community Disaster Loans; 97.031, Cora Brown Fund; 97.032, Crisis Counseling; 97.033, Disaster Legal Services; 97.034, Disaster Unemployment Assistance (DUA); 97.046, Fire Management Assistance Grant; 97.048, Disaster Housing Assistance to Individuals and Households In Presidentially Declared Disaster Areas; 97.049, Presidentially Declared Disaster Assistance—Disaster Housing Operations for Individuals and Households; 97.050, Presidentially Declared Disaster Assistance to Individuals and Households—Other Needs; 97.036, Disaster Grants—Public Assistance

(Presidentially Declared Disasters); 97.039, Hazard Mitigation Grant.

**Deanne Criswell,**

*Administrator, Federal Emergency Management Agency.*

[FR Doc. 2022-02257 Filed 2-2-22; 8:45 am]

**BILLING CODE 9111-23-P**

## DEPARTMENT OF HOMELAND SECURITY

### Federal Emergency Management Agency

[Internal Agency Docket No. FEMA-4598-DR; Docket ID FEMA-2022-0001]

#### Mississippi; Amendment No. 2 to Notice of a Major Disaster Declaration

**AGENCY:** Federal Emergency Management Agency, DHS.

**ACTION:** Notice.

**SUMMARY:** This notice amends the notice of a major disaster declaration for State of Mississippi (FEMA-4598-DR), dated May 4, 2021, and related determinations.

**DATES:** This change occurred on January 14, 2022.

**FOR FURTHER INFORMATION CONTACT:** Dean Webster, Office of Response and Recovery, Federal Emergency Management Agency, 500 C Street SW, Washington, DC 20472, (202) 646-2833.

**SUPPLEMENTARY INFORMATION:** The Federal Emergency Management Agency (FEMA) hereby gives notice that pursuant to the authority vested in the Administrator, under Executive Order 12148, as amended, James R. Stephenson, of FEMA is appointed to act as the Federal Coordinating Officer for this disaster.

This action terminates the appointment of Brett H. Howard as Federal Coordinating Officer for this disaster.

The following Catalog of Federal Domestic Assistance Numbers (CFDA) are to be used for reporting and drawing funds: 97.030, Community Disaster Loans; 97.031, Cora Brown Fund; 97.032, Crisis Counseling; 97.033, Disaster Legal Services; 97.034, Disaster Unemployment Assistance (DUA); 97.046, Fire Management Assistance Grant; 97.048, Disaster Housing Assistance to Individuals and Households In Presidentially Declared Disaster Areas; 97.049, Presidentially Declared Disaster Assistance—Disaster Housing Operations for Individuals and Households; 97.050, Presidentially Declared Disaster Assistance to Individuals and Households—Other Needs; 97.036, Disaster Grants—Public Assistance

(Presidentially Declared Disasters); 97.039, Hazard Mitigation Grant.

**Deanne Criswell,**

*Administrator, Federal Emergency Management Agency.*

[FR Doc. 2022-02259 Filed 2-2-22; 8:45 am]

**BILLING CODE 9111-23-P**

## DEPARTMENT OF HOMELAND SECURITY

### Notice of the Establishment of the Cyber Safety Review Board

**AGENCY:** Department of Homeland Security (DHS), Cybersecurity and Infrastructure Security Agency (CISA).

**ACTION:** Notice of new review board establishment.

**SUMMARY:** The Secretary of Homeland Security (Secretary), in consultation with the Attorney General, is establishing the Cyber Safety Review Board (CSRB) as directed by the Executive Order titled, Improving the Nation's Cybersecurity, and pursuant to the Homeland Security Act of 2002. DHS is announcing the establishment of the CSRB, a new review board, for public awareness.

**FOR FURTHER INFORMATION CONTACT:** Erin McJeon, 202-819-6196 or [CyberSafetyReviewBoard@cisa.dhs.gov](mailto:CyberSafetyReviewBoard@cisa.dhs.gov).

**SUPPLEMENTARY INFORMATION:** The Secretary, in consultation with the Attorney General, chartered the CSRB as directed by Executive Order 14028 and pursuant to 6 U.S.C. 451. The CSRB, which was chartered on September 21, 2021, will operate in an advisory capacity only.

The CSRB will convene following significant cyber incidents that trigger the establishment of a Cyber Unified Coordination Group as provided by section V(B)(2) of Presidential Policy Directive (PPD) 41; at any time as directed by the President acting through the Assistant to the President for National Security Affairs (APNSA); or at any time the Secretary or CISA Director deems necessary. Upon completion of its review of an applicable incident, the CSRB may develop advice, information, or recommendations for the Secretary for improving cybersecurity and incident response practices and policy. The Secretary, in consultation with the Attorney General, shall provide to the President, through the APNSA, any advice, information, and recommendations of the CSRB for improving cybersecurity and incident response practices and policy.

Whenever possible, the CSRB's advice, information, or

recommendations will be made publicly available, with any appropriate redactions, consistent with applicable law and the need to protect sensitive information from disclosure.

Some of the issues the CSRB will address may require members to have access to classified information as well as sensitive law enforcement, operational, business, and other confidential information.

In recognition of the sensitive material utilized in CSRB activities and discussions, the Secretary has exempted the CSRB from Public Law 92-463, *The Federal Advisory Committee Act*, 5 U.S.C. app.

**Membership:** The CSRB shall be composed of no more than 20 members who are appointed by the CISA Director, in coordination with the DHS Under Secretary for Strategy, Policy, and Plans. The DHS Under Secretary for Strategy, Policy, and Plans shall serve as the inaugural Chair of the CSRB for a term of two years. Members will include at least one representative from the Department of Defense, the Department of Justice, DHS, CISA, the National Security Agency, and the Federal Bureau of Investigation. CSRB members will also include individuals from private sector entities to include appropriate cybersecurity or software suppliers.

Non-governmental members who serve on the CSRB will serve as Special Government Employees as defined in 18 U.S.C. 202(a). Members may be required to sign a non-disclosure agreement. Members may also be required to obtain a security clearance. Members shall consist of subject matter experts from appropriate professions and diverse communities nationwide, be geographically balanced, and shall include representatives of a broad and inclusive range of industries.

A representative from the Office of Management and Budget shall participate in CSRB activities when an incident under review involves Federal Civilian Executive Branch (FCEB) Information Systems, as determined by the CISA Director, and other individuals may be invited to participate in CSRB activities on a case-by-case basis depending on the nature of the incident under review.

**Duration:** Unless otherwise directed by the President, the Secretary may extend the life of the CSRB every two years as the Secretary deems appropriate, pursuant to 6 U.S.C. 451.

**Alejandro N. Mayorkas,**

*Secretary, Department of Homeland Security.*

[FR Doc. 2022-02171 Filed 2-2-22; 8:45 am]

**BILLING CODE 9110-9P-P**



managed by the Natural Resource Stewardship and Science Directorate. The system assists the NPS in making informed decisions regarding a number of compliance issues throughout the planning, design, and construction process.

DOI is publishing this revised notice to reflect updates to the system location, system manager, categories of records, records source, records retrieval, records retention and disposal, and safeguards; include new sections for security classification, purpose and history of the system of records; and make general updates to the remaining sections to accurately reflect management of the system of records in accordance with the Office of Management and Budget (OMB) Circular A-108, *Federal Agency Responsibilities for Review, Reporting, and Publication under the Privacy Act*. DOI is proposing to modify existing routine uses and add new routine uses to provide clarity, transparency, and to facilitate sharing of information with agencies and organizations to promote the integrity of the records in the system or carry out a statutory responsibility of the DOI or Federal Government.

Routine use A was slightly modified to further clarify disclosures to the Department of Justice (DOJ) or other Federal agencies, when necessary, in relation to litigation or judicial hearings. Routine use B was modified to clarify disclosures to a congressional office to respond to or resolve an individual's request made to that office. Routine use H was modified to clarify sharing of information with government agencies and organizations in response to court orders or for discovery purposes related to litigation. Routine use I was modified to include grantees to facilitate sharing of information when authorized and necessary to perform services on DOI's behalf. Modified routine use J allows DOI to share information with appropriate Federal agencies or entities when reasonably necessary to respond to a breach of PII and to prevent, minimize, or remedy the risk of harm to individuals or the Federal Government, or assist an agency in locating individuals affected by a breach in accordance with OMB Memorandum M-17-12, *Preparing for and Responding to a Breach of Personally Identifiable Information*. Routine use N was modified to include review by public affairs, legal counsel, and the Senior Agency Official for Privacy and clarify circumstances where there is a legitimate public interest in the disclosure of information that would not constitute an unwarranted invasion of privacy.

Proposed new routine use C facilitates sharing of information with the Executive Office of the President to resolve issues concerning individuals' records. Proposed routine use P allows sharing with members of the public in order to provide copies or summaries of comments received on a project, and to provide information to the public as a report or verification of all correspondence received for a project, or as part of the process of reporting the public's concerns on a project and the NPS's response to those concerns.

## II. Privacy Act

The Privacy Act of 1974, as amended, embodies fair information practice principles in a statutory framework governing the means by which Federal agencies collect, maintain, use, and disseminate individuals' records. The Privacy Act applies to records about individuals that are maintained in a "system of records." A "system of records" is a group of any records under the control of an agency from which information is retrieved by the name of an individual or by some identifying number, symbol, or other identifying particulars assigned to the individual. The Privacy Act defines an individual as a United States citizen or lawful permanent resident. Individuals may request access to their own records that are maintained in a system of records in the possession or under the control of DOI by complying with DOI Privacy Act regulations at 43 CFR part 2, subpart K, and following the procedures outlined in the Records Access, Contesting Record, and Notification Procedures sections of this notice.

The Privacy Act requires each agency to publish in the **Federal Register** a description denoting the existence and character of each system of records that the agency maintains, and the routine uses of each system. The INTERIOR/NPS-23, Planning, Environment and Public Comment (PEPC) System, SORN is published in its entirety below. In accordance with 5 U.S.C. 552a(r), DOI has provided a report of this system of records to OMB and to Congress.

## III. Public Participation

You should be aware your entire comment including your personally identifiable information, such as your address, phone number, email address, or any other personal information in your comment, may be made publicly available at any time. While you may request to withhold your personally identifiable information from public review, we cannot guarantee we will be able to do so.

### SYSTEM NAME AND NUMBER:

INTERIOR/NPS-23, Planning, Environment and Public Comment (PEPC) System.

### SECURITY CLASSIFICATION:

Unclassified.

### SYSTEM LOCATION:

This system is located at the National Information Technology Center, National Park Service, 12201 Sunrise Valley Drive, Reston, VA 20192. Records may also be located at NPS regional and field offices responsible for projects related to conservation planning and environmental impact analysis. A current listing of park offices and contact information may be obtained by visiting the NPS website at <https://www.nps.gov/aboutus/contactinformation.htm>.

### SYSTEM MANAGER(S):

Chief, Environmental Information Management Branch, Environmental Quality Division, Natural Resource Stewardship and Science, National Park Service, P.O. Box 25287, Denver, CO 80225-0287.

### AUTHORITY FOR MAINTENANCE OF THE SYSTEM:

42 U.S.C. 4321 *et seq.*, The National Environmental Policy Act of 1969, as amended; and 43 CFR part 46, Implementation of the National Environmental Policy Act of 1969.

### PURPOSE(S) OF THE SYSTEM:

The PEPC System is a collaborative online tool designed to: (1) Facilitate the project management process in conservation planning and environmental impact analysis; (2) assist NPS employees in making informed decisions regarding pertinent compliance issues throughout the planning, design, and construction process; (3) provide consistency in applying applicable policies, laws and regulations; and (4) provide a platform for public comment opportunities for environmental impact analysis and other documents that require public input.

### CATEGORIES OF INDIVIDUALS COVERED BY THE SYSTEM:

Individuals covered by the system include DOI employees, contractors and volunteers; other Federal, state or local government agency employees, contractors and volunteers; partners of NPS that are involved in the projects; members of the public providing and seeking comments on the projects; and other individuals involved with projects related to conservation planning and environmental impact analysis.

**CATEGORIES OF RECORDS IN THE SYSTEM:**

The system contains documents necessary to track compliance, milestones, and status of projects related to conservation planning and environmental impact analysis. These records may include name, home or business address, home or business telephone number, home or business email address, organization affiliation, correspondent identification number, project number, and unique correspondence identification number for each correspondence record received. The correspondent identification number is a unique number in the database that can be used to query the correspondent's information.

**RECORD SOURCE CATEGORIES:**

Records in the PEPC System are obtained from DOI employees, contractors, and volunteers; other Federal, state, or local government agency employees, contractors, and volunteers; partners; tribes; members of the public; comments posted on regulations.gov; and other individuals involved with projects related to conservation planning and environmental impact analysis.

**ROUTINE USES OF RECORDS MAINTAINED IN THE SYSTEM, INCLUDING CATEGORIES OF USERS AND THE PURPOSES OF SUCH USES:**

In addition to those disclosures generally permitted under 5 U.S.C. 552a(b) of the Privacy Act, all or a portion of the records or information contained in this system may be disclosed outside DOI as a routine use pursuant to 5 U.S.C. 552a(b)(3) as follows:

A. To the Department of Justice (DOJ), including Offices of the U.S. Attorneys, or other Federal agency conducting litigation or in proceedings before any court, adjudicative, or administrative body, when it is relevant or necessary to the litigation and one of the following is a party to the litigation or has an interest in such litigation:

- (1) DOI or any component of DOI;
- (2) Any other Federal agency appearing before the Office of Hearings and Appeals;
- (3) Any DOI employee or former employee acting in his or her official capacity;
- (4) Any DOI employee or former employee acting in his or her individual capacity when DOI or DOJ has agreed to represent that employee or pay for private representation of the employee; or

(5) The United States Government or any agency thereof, when DOJ determines that DOI is likely to be affected by the proceeding.

B. To a congressional office when requesting information on behalf of, and at the request of, the individual who is the subject of the record.

C. To the Executive Office of the President in response to an inquiry from that office made at the request of the subject of a record or a third party on that person's behalf, or for a purpose compatible with the reason for which the records are collected or maintained.

D. To any criminal, civil, or regulatory law enforcement authority (whether Federal, state, territorial, local, tribal or foreign) when a record, either alone or in conjunction with other information, indicates a violation or potential violation of law—criminal, civil, or regulatory in nature, and the disclosure is compatible with the purpose for which the records were compiled.

E. To an official of another Federal agency to provide information needed in the performance of official duties related to reconciling or reconstructing data files or to enable that agency to respond to an inquiry by the individual to whom the record pertains.

F. To Federal, state, territorial, local, tribal, or foreign agencies that have requested information relevant or necessary to the hiring, firing or retention of an employee or contractor, or the issuance of a security clearance, license, contract, grant or other benefit, when the disclosure is compatible with the purpose for which the records were compiled.

G. To representatives of the National Archives and Records Administration (NARA) to conduct records management inspections under the authority of 44 U.S.C. 2904 and 2906.

H. To state, territorial and local governments and tribal organizations to provide information needed in response to court order and/or discovery purposes related to litigation, when the disclosure is compatible with the purpose for which the records were compiled.

I. To an expert, consultant, grantee, or contractor (including employees of the contractor) of DOI that performs services requiring access to these records on DOI's behalf to carry out the purposes of the system.

J. To appropriate agencies, entities, and persons when:

(1) DOI suspects or has confirmed that there has been a breach of the system of records;

(2) DOI has determined that as a result of the suspected or confirmed breach there is a risk of harm to individuals, DOI (including its information systems, programs, and operations), the Federal Government, or national security; and

(3) the disclosure made to such agencies, entities, and persons is reasonably necessary to assist in connection with DOI's efforts to respond to the suspected or confirmed breach or to prevent, minimize, or remedy such harm.

K. To another Federal agency or Federal entity, when DOI determines that information from this system of records is reasonably necessary to assist the recipient agency or entity in:

(1) Responding to a suspected or confirmed breach; or

(2) preventing, minimizing, or remedying the risk of harm to individuals, the recipient agency or entity (including its information systems, programs, and operations), the Federal Government, or national security, resulting from a suspected or confirmed breach.

L. To the Office of Management and Budget (OMB) during the coordination and clearance process in connection with legislative affairs as mandated by OMB Circular A-19.

M. To the Department of the Treasury to recover debts owed to the United States.

N. To the news media and the public, with the approval of the Public Affairs Officer in consultation with counsel and the Senior Agency Official for Privacy, where there exists a legitimate public interest in the disclosure of the information, except to the extent it is determined that release of the specific information in the context of a particular case would constitute an unwarranted invasion of personal privacy.

O. To officials of another Federal, state, local, or tribal agency to retrieve, review or analyze public comments for projects under their authority, which were received via the PEPC System.

P. To members of the public in order to provide copies or summaries of comments received on a project, and to provide information to the public as a report or verification of all correspondence received for a project, or as part of the process of reporting the public's concerns on a project and the NPS's response to those concerns.

**DISCLOSURE TO CONSUMER REPORTING AGENCIES:**

Disclosure pursuant to 5 U.S.C. 552a(b)(12). Disclosures may be made from this system to consumer reporting agencies as defined in the Fair Credit Reporting Act (15 U.S.C. 1681a(f)) or the Federal Claims Collection Act of 1966 (31 U.S.C. 3701(a)(3)).

**POLICIES AND PRACTICES FOR STORAGE OF RECORDS:**

Paper records are contained in file folders stored within filing cabinets. Electronic records are contained in computers, magnetic disks, computer tapes, removable drives, email, and electronic databases.

**POLICIES AND PRACTICES FOR RETRIEVAL OF RECORDS:**

The information may be retrieved by various fields including correspondent's name, project number, correspondence's identification number, correspondent's identification number, document identification number, park, organization type, affiliation, or correspondence receipt date.

**POLICIES AND PRACTICES FOR RETENTION AND DISPOSAL OF RECORDS:**

Records are retained in accordance with the National Park Service Records Schedule, Resource Management and Lands (Item 1C), which has been approved by NARA (Job No. N1-79-0801). The disposition of records with short-term operational value and not considered essential for ongoing management of land, cultural and natural resources is temporary, including account management records. These operational records are destroyed/deleted 15 years after closure. The disposition for routine housekeeping and supporting documentation is temporary and records are destroyed/deleted 3 years after closure.

Approved disposition methods for records include shredding or pulping paper records and erasing or degaussing electronic records in accordance with NARA guidelines and Departmental policy. Detailed disposition procedures and processes will be defined, implemented, and published to internal system administration staff within the PEPC technical reference manuals.

**ADMINISTRATIVE, TECHNICAL, AND PHYSICAL SAFEGUARDS:**

The records contained in this system are safeguarded in accordance with 43 CFR 2.226 and other applicable security rules and policies. Access to records in the PEPC System is limited to authorized personnel whose official duties require such access. Paper records are secured in file cabinets in areas which are locked during non-duty hours.

Computerized records systems follow the National Institute of Standards and Technology privacy and security standards as developed to comply with the Privacy Act of 1974, as amended, 5 U.S.C. 552a; Paperwork Reduction Act of 1995, 44 U.S.C. 3501 *et seq*; Federal

Information Security Modernization Act of 2014, 44 U.S.C. 3551 *et seq*; and the Federal Information Processing Standards 199: Standards for Security Categorization of Federal Information and Information Systems. Security controls include user identification, passwords, database permissions, encryption, firewalls, audit logs, network system security monitoring, and software controls.

Database tables are kept on separate file servers away from general file storage and other local area network usage. The data itself is stored in a password-protected, client-server database. Security measures establish access levels for different types of users.

Personnel authorized to access the system must complete all security, privacy, and records management training and sign the DOI Rules of Behavior. A Privacy Impact Assessment was conducted on the PEPC System to ensure that Privacy Act requirements are met, and appropriate privacy controls were implemented to safeguard the personally identifiable information contained in the system.

**RECORD ACCESS PROCEDURES:**

An individual requesting records on himself or herself should send a signed, written inquiry to the applicable System Manager identified above. The request must include the specific bureau or office that maintains the record to facilitate location of the applicable records. The request envelope and letter should both be clearly marked "PRIVACY ACT REQUEST FOR ACCESS." A request for access must meet the requirements of 43 CFR 2.238.

**CONTESTING RECORD PROCEDURES:**

An individual requesting corrections or the removal of material from his or her records should send a signed, written request to the applicable System Manager as identified above. The request must include the specific bureau or office that maintains the record to facilitate location of the applicable records. A request for corrections or removal must meet the requirements of 43 CFR 2.246.

**NOTIFICATION PROCEDURES:**

An individual requesting notification of the existence of records on himself or herself should send a signed, written inquiry to the applicable System Manager as identified above. The request must include the specific bureau or office that maintains the record to facilitate location of the applicable records. The request envelope and letter should both be clearly marked "PRIVACY ACT INQUIRY." A request

for notification must meet the requirements of 43 CFR 2.235.

**EXEMPTIONS PROMULGATED FOR THE SYSTEM:**

None.

**HISTORY:**

79 FR 30641 (May 28, 2014), modification published at 86 FR 50156 (September 7, 2021).

**Teri Barnett,**

*Departmental Privacy Officer, Department of the Interior.*

[FR Doc. 2022-02294 Filed 2-2-22; 8:45 am]

**BILLING CODE 4312-52-P**

**DEPARTMENT OF THE INTERIOR****Bureau of Reclamation**

[RR83550000, 223R5065C6, RX.59389832.1009676]

**Change in Discount Rate for Water Resources Planning**

**AGENCY:** Bureau of Reclamation, Interior.

**ACTION:** Notice of change in discount rate.

**SUMMARY:** The Bureau of Reclamation is announcing the interest rate to be used by Federal agencies in the formulation and evaluation of plans for water and related land resources is 2.25 percent for fiscal year 2022.

**DATES:** This discount rate is to be used for the period October 1, 2021, through and including September 30, 2022.

**FOR FURTHER INFORMATION CONTACT:**

Brandee Blumenthal, Bureau of Reclamation, Reclamation Law Administration Division, P.O. Box 25007, Denver, Colorado 80225; telephone (303) 445-2435; or email at [bblumenthal@usbr.gov](mailto:bblumenthal@usbr.gov).

**SUPPLEMENTARY INFORMATION:** The Water Resources Planning Act of 1965 and the Water Resources Development Act of 1974 require an annual determination of a discount rate for Federal water resources planning. The discount rate for Federal water resources planning for fiscal year 2022 is 2.25 percent. The prior year's rate, as announced in the **Federal Register** on December 11, 2020 (85 FR 80148), was 2.50 percent for fiscal year 2021. Discounting is to be used to convert future monetary values to present values.

This rate has been computed in accordance with Section 80(a), Public Law 93-251 (88 Stat. 34), and 18 CFR 704.39, which: (1) Specify that the rate will be based upon the average yield during the preceding fiscal year on interest-bearing marketable securities of

the United States which, at the time the computation is made, have terms of 15 years or more remaining to maturity (average yield is rounded to nearest one-eighth percent); and (2) provide that the rate will not be raised or lowered more than one-quarter of 1 percent for any year. The U.S. Department of the Treasury calculated the specified average to be 1.8669 percent. In accordance with the Water Resource Council Rules and Regulations, the maximum adjustment allowed for the current fiscal year rate is one-quarter of one percentage point from the previous fiscal year rate, which was 2.50 percent. Therefore, the fiscal year 2022 rate is 2.25 percent.

The rate of 2.25 percent will be used by all Federal agencies in the formulation and evaluation of water and related land resources plans for the purpose of discounting future benefits and computing costs or otherwise converting benefits and costs to a common-time basis.

**Christopher Beardsley,**

*Director, Policy and Programs.*

[FR Doc. 2022-02295 Filed 2-2-22; 8:45 am]

**BILLING CODE 4332-90-P**

## DEPARTMENT OF THE INTERIOR

### Bureau of Reclamation

[RR85854000, 223R5065C6,  
RX.59689831.0000000; OMB Control  
Number 1006-NEW]

#### Agency Information Collection Activities; Technical Service Center Summer Intern Program Application

**AGENCY:** Bureau of Reclamation,  
Interior.

**ACTION:** Notice of information collection;  
request for comment.

**SUMMARY:** In accordance with the Paperwork Reduction Act of 1995, we, the Bureau of Reclamation (Reclamation), are proposing a new information collection that is currently in use without OMB approval. The publication of this 60-day notice is the first step in bringing this information collection into compliance.

**DATES:** Interested persons are invited to submit comments on or before April 4, 2022.

**ADDRESSES:** Send your comments on this information collection request (ICR) by mail to Jessica Torrey, Supervisory Civil Engineer, Denver Federal Center, P.O. Box 25007, MS 86-68540, Denver, CO 80225; or by email to [jtorrey@usbr.gov](mailto:jtorrey@usbr.gov). Please reference OMB Control

Number 1006-NEW in the subject line of your comments.

**FOR FURTHER INFORMATION CONTACT:** To request additional information about this ICR, contact Jessica Torrey by email at [jtorrey@usbr.gov](mailto:jtorrey@usbr.gov), or by telephone at (303) 445-2376. Individuals who are hearing or speech impaired may call the Federal Relay Service at (800) 877-8339 for TTY assistance.

**SUPPLEMENTARY INFORMATION:** In accordance with the Paperwork Reduction Act of 1995 (PRA, 44 U.S.C. 3501 *et seq.*) and 5 CFR 1320.8(d)(1), all information collections require approval under the PRA. We may not conduct or sponsor and you are not required to respond to a collection of information unless it displays a currently valid OMB control number.

As part of our continuing effort to reduce paperwork and respondent burdens, we invite the public and other Federal agencies to comment on new, proposed, revised, and continuing collections of information. This helps us assess the impact of our information collection requirements and minimize the public's reporting burden. It also helps the public understand our information collection requirements and provide the requested data in the desired format.

We are especially interested in public comment addressing the following:

- (1) Whether or not the collection of information is necessary for the proper performance of the functions of the agency, including whether or not the information will have practical utility;
- (2) The accuracy of our estimate of the burden for this collection of information, including the validity of the methodology and assumptions used;
- (3) Ways to enhance the quality, utility, and clarity of the information to be collected; and
- (4) How might the agency minimize the burden of the collection of information on those who are to respond, including through the use of appropriate automated, electronic, mechanical, or other technological collection techniques or other forms of information technology, *e.g.*, permitting electronic submission of response.

Comments that you submit in response to this notice are a matter of public record. We will include or summarize each comment in our request to OMB to approve this ICR. Before including your address, phone number, email address, or other personal identifying information in your comment, you should be aware that your entire comment—including your personal identifying information—may be made publicly available at any time.

While you can ask us in your comment to withhold your personal identifying information from public review, we cannot guarantee that we will be able to do so.

**Abstract:** The principal purpose for collecting the requested information is to recruit eligible students to participate in Reclamation's Technical Service Center Summer Intern Program. General contact information will be collected along with information on academic standing and areas/fields of interest. Respondents are also asked to submit an interest letter and resume.

**Title of Collection:** Technical Service Center Summer Intern Program Application.

**OMB Control Number:** 1006-NEW.

**Form Numbers:** 7-3000.

**Type of Review:** In Use Without OMB Approval.

**Respondents/Affected Public:** Students interested in internships at Reclamation.

**Total Estimated Number of Annual Respondents:** 150.

**Total Estimated Number of Annual Responses:** 150.

**Estimated Completion Time per Response:** 140 minutes.

**Total Estimated Number of Annual Burden Hours:** 350 hours.

**Respondent's Obligation:** Required to obtain or retain a benefit.

**Frequency of Collection:** Annually.

**Total Estimated Annual Non-hour Burden Cost:** \$0.

An agency may not conduct or sponsor and a person is not required to respond to a collection of information unless it displays a currently valid OMB control number.

The authority for this action is the Paperwork Reduction Act of 1995 (44 U.S.C. 3501 *et seq.*)

**Richard LaFond,**

*Director, Technical Service Center.*

[FR Doc. 2022-02296 Filed 2-2-22; 8:45 am]

**BILLING CODE 4332-90-P**

## INTERNATIONAL TRADE COMMISSION

[Investigation No. 337-TA-1297]

### Certain Video Processing Devices, Components Thereof, and Digital Smart Televisions Containing the Same II; Institution of Investigation

**AGENCY:** U.S. International Trade Commission.

**ACTION:** Notice.

**SUMMARY:** Notice is hereby given that a complaint was filed with the U.S. International Trade Commission on

November 24, 2021, under section 337 of the Tariff Act of 1930, as amended, on behalf of DivX, LLC of San Diego, California. The complaint was supplemented by letter on December 7, 2021, and an amended complaint was filed on December 28, 2021. The complaint, as amended, alleges violations of section 337 based upon the importation into the United States, the sale for importation, and the sale within the United States after importation of certain video processing devices, components thereof, and digital smart televisions containing the same by reason of infringement of one or more claims of U.S. Patent No. 8,832,297 (“the ‘297 patent”) and U.S. Patent No. 8,472,792 (“the ‘792 patent”). The amended complaint further alleges that an industry in the United States exists or is in the process of being established as required by the applicable Federal Statute.

The complainant requests that the Commission institute an investigation and, after the investigation, issue a limited exclusion order and cease and desist orders.

**ADDRESSES:** The complaint, as amended, except for any confidential information contained therein, may be viewed on the Commission’s electronic docket (EDIS) at <https://edis.usitc.gov>. For help accessing EDIS, please email [EDIS3Help@usitc.gov](mailto:EDIS3Help@usitc.gov). Hearing impaired individuals are advised that information on this matter can be obtained by contacting the Commission’s TDD terminal on (202) 205–1810. Persons with mobility impairments who will need special assistance in gaining access to the Commission should contact the Office of the Secretary at (202) 205–2000. General information concerning the Commission may also be obtained by accessing its internet server at <https://www.usitc.gov>.

**FOR FURTHER INFORMATION CONTACT:** Jessica Mullan, Office of Docket Services, U.S. International Trade Commission, telephone (202) 205–1802.

**SUPPLEMENTARY INFORMATION:**

*Authority:* The authority for institution of this investigation is contained in section 337 of the Tariff Act of 1930, as amended, 19 U.S.C. 1337, and in section 210.10 of the Commission’s Rules of Practice and Procedure, 19 CFR 210.10 (2021).

*Scope of investigation:* Having considered the complaint, the U.S. International Trade Commission, on January 28, 2022, *Ordered that—*

(1) Pursuant to subsection (b) of section 337 of the Tariff Act of 1930, as amended, an investigation be instituted to determine whether there is a

violation of subsection (a)(1)(B) of section 337 in the importation into the United States, the sale for importation, or the sale within the United States after importation of certain products identified in paragraph (2) by reason of infringement of one or more of claims 1–11 and 14–17 of the ‘297 patent and claims 15–23 of the ‘792 patent, and whether an industry in the United States exists as required by subsection (a)(2) of section 337;

(2) Pursuant to section 210.10(b)(1) of the Commission’s Rules of Practice and Procedure, 19 CFR 210.10(b)(1), the plain language description of the accused products or category of accused products, which defines the scope of the investigation, is “certain video processing devices, components thereof, and digital smart televisions containing the same, including printed circuit board assemblies for use in video processing in digital smart televisions and associated software and/or firmware”;

(3) For the purpose of the investigation so instituted, the following are hereby named as parties upon which this notice of investigation shall be served:

(a) The complainant is:  
DivX, LLC, 4350 La Jolla Village Drive, Suite 950, San Diego, California 92122

(b) The respondents are the following entities alleged to be in violation of section 337, and are the parties upon which the amended complaint is to be served:

TCL Technology Group Corporation,  
TCL Technology Building No. 17,  
Huifeng 3rd Road, Zhongkai High-Tech Development District, Huizhou, Guangdong, 516006, China

TCL Electronics Holdings Limited, 9 Floor, TCL Electronics Holdings Limited Building, TCL International E City, #1001 Zhongshan Park Road, Nanshan District, Shenzhen, Guangdong, 518067, China

TTE Technology, Inc., 1860 Compton Avenue, Corona, CA 92881, Shenzhen TCL New Technologies Co. Ltd., 9 Floor, TCL Electronics Holdings Limited Building, TCL International E City, #1001 Zhongshan Park Road, Nanshan District, Shenzhen, Guangdong, 518067, China

TCL King Electrical Appliances (Huizhou) Co. Ltd., No. 78, 4th Huifeng Rd, Zhongkai New & High-Tech Industries, Development Zone, Huizhou, Guangdong, 516006, China

TCL MOKA International Limited, 7/F Hong Kong Science Park, Building 22 E, 22 Science Park East Avenue, Sha Tin, New Territories, Hong Kong

TCL Smart Device (Vietnam) Co., Ltd, No. 26 VSIP II–A, Street 32, Vietnam

Singapore Industrial Park II–A, Tan Binh Commune, Bac Tan Uyen District, Binh Duong Province, 75000, Vietnam; and

(4) For the investigation so instituted, the Chief Administrative Law Judge, U.S. International Trade Commission, shall designate the presiding Administrative Law Judge.

The Office of Unfair Import Investigations will not be participating as a party in this investigation.

Responses to the amended complaint and the notice of investigation must be submitted by the named respondents in accordance with section 210.13 of the Commission’s Rules of Practice and Procedure, 19 CFR 210.13. Pursuant to 19 CFR 201.16(e) and 210.13(a), as amended in 85 FR 15798 (March 19, 2020), such responses will be considered by the Commission if received not later than 20 days after the date of service by the complainant of the complaint and the notice of investigation. Extensions of time for submitting responses to the amended complaint and the notice of investigation will not be granted unless good cause therefor is shown.

Failure of a respondent to file a timely response to each allegation in the amended complaint and in this notice may be deemed to constitute a waiver of the right to appear and contest the allegations of the amended complaint and this notice, and to authorize the administrative law judge and the Commission, without further notice to the respondent, to find the facts to be as alleged in the amended complaint and this notice and to enter an initial determination and a final determination containing such findings, and may result in the issuance of an exclusion order or a cease and desist order or both directed against the respondent.

By order of the Commission.

Issued: January 31, 2022.

**Lisa Barton,**

*Secretary to the Commission.*

[FR Doc. 2022–02307 Filed 2–2–22; 8:45 am]

**BILLING CODE 7020–02–P**

## INTERNATIONAL TRADE COMMISSION

### Notice of Receipt of Complaint; Solicitation of Comments Relating to the Public Interest

**AGENCY:** U.S. International Trade Commission.

**ACTION:** Notice.

**SUMMARY:** Notice is hereby given that the U.S. International Trade Commission has received a complaint



entitled *Certain Products Containing Pyraclostrobin and Components Thereof*, DN 3600; the Commission is soliciting comments on any public interest issues raised by the complaint or complainant's filing pursuant to the Commission's Rules of Practice and Procedure.

**FOR FURTHER INFORMATION CONTACT:** Lisa R. Barton, Secretary to the Commission, U.S. International Trade Commission, 500 E Street SW, Washington, DC 20436, telephone (202) 205-2000. The public version of the complaint can be accessed on the Commission's Electronic Document Information System (EDIS) at <https://edis.usitc.gov>. For help accessing EDIS, please email [EDIS3Help@usitc.gov](mailto:EDIS3Help@usitc.gov).

General information concerning the Commission may also be obtained by accessing its internet server at United States International Trade Commission (USITC) at <https://www.usitc.gov>. The public record for this investigation may be viewed on the Commission's Electronic Document Information System (EDIS) at <https://edis.usitc.gov>. Hearing-impaired persons are advised that information on this matter can be obtained by contacting the Commission's TDD terminal on (202) 205-1810.

**SUPPLEMENTARY INFORMATION:** The Commission has received a complaint and a submission pursuant to § 210.8(b) of the Commission's Rules of Practice and Procedure filed on behalf of BASF SE and BASF Corporation on January 28, 2022. The complaint alleges violations of section 337 of the Tariff Act of 1930 (19 U.S.C. 1337) in the importation into the United States, the sale for importation, and the sale within the United States after importation of certain products containing pyraclostrobin and components thereof. The complainant names as respondents: Sharda Cropchem Ltd. of India and Sharda USA LLC of Norristown, PA. The complainant requests that the Commission issue a limited exclusion order, cease and desist orders, and impose a bond upon respondents alleged infringing articles during the 60-day Presidential review period pursuant to 19 U.S.C. 1337(j). Proposed respondents, other interested parties, and members of the public are invited to file comments on any public interest issues raised by the complaint or § 210.8(b) filing. Comments should address whether issuance of the relief specifically requested by the complainant in this investigation would affect the public health and welfare in the United States, competitive

conditions in the United States economy, the production of like or directly competitive articles in the United States, or United States consumers.

In particular, the Commission is interested in comments that:

- (i) Explain how the articles potentially subject to the requested remedial orders are used in the United States;
- (ii) identify any public health, safety, or welfare concerns in the United States relating to the requested remedial orders;
- (iii) identify like or directly competitive articles that complainant, its licensees, or third parties make in the United States which could replace the subject articles if they were to be excluded;
- (iv) indicate whether complainant, complainant's licensees, and/or third party suppliers have the capacity to replace the volume of articles potentially subject to the requested exclusion order and/or a cease and desist order within a commercially reasonable time; and
- (v) explain how the requested remedial orders would impact United States consumers.

Written submissions on the public interest must be filed no later than by close of business, eight calendar days after the date of publication of this notice in the **Federal Register**. There will be further opportunities for comment on the public interest after the issuance of any final initial determination in this investigation. Any written submissions on other issues must also be filed by no later than the close of business, eight calendar days after publication of this notice in the **Federal Register**. Complainant may file replies to any written submissions no later than three calendar days after the date on which any initial submissions were due. No other submissions will be accepted, unless requested by the Commission. Any submissions and replies filed in response to this Notice are limited to five (5) pages in length, inclusive of attachments.

Persons filing written submissions must file the original document electronically on or before the deadlines stated above. Submissions should refer to the docket number ("Docket No. 3600") in a prominent place on the cover page and/or the first page. (See Handbook for Electronic Filing Procedures, Electronic Filing

Procedures.<sup>1</sup>) Please note the Secretary's Office will accept only electronic filings during this time. Filings must be made through the Commission's Electronic Document Information System (EDIS, <https://edis.usitc.gov>.) No in-person paper-based filings or paper copies of any electronic filings will be accepted until further notice. Persons with questions regarding filing should contact the Secretary at [EDIS3Help@usitc.gov](mailto:EDIS3Help@usitc.gov).

Any person desiring to submit a document to the Commission in confidence must request confidential treatment. All such requests should be directed to the Secretary to the Commission and must include a full statement of the reasons why the Commission should grant such treatment. See 19 CFR 201.6. Documents for which confidential treatment by the Commission is properly sought will be treated accordingly. All information, including confidential business information and documents for which confidential treatment is properly sought, submitted to the Commission for purposes of this Investigation may be disclosed to and used: (i) By the Commission, its employees and Offices, and contract personnel (a) for developing or maintaining the records of this or a related proceeding, or (b) in internal investigations, audits, reviews, and evaluations relating to the programs, personnel, and operations of the Commission including under 5 U.S.C. Appendix 3; or (ii) by U.S. government employees and contract personnel,<sup>2</sup> solely for cybersecurity purposes. All nonconfidential written submissions will be available for public inspection at the Office of the Secretary and on EDIS.<sup>3</sup>

This action is taken under the authority of section 337 of the Tariff Act of 1930, as amended (19 U.S.C. 1337), and of §§ 201.10 and 210.8(c) of the Commission's Rules of Practice and Procedure (19 CFR 201.10, 210.8(c)).

By order of the Commission.

Issued: January 31, 2022.

**Lisa R. Barton,**

*Secretary to the Commission.*

[FR Doc. 2022-02306 Filed 2-2-22; 8:45 am]

**BILLING CODE 7020-02-P**

<sup>1</sup> Handbook for Electronic Filing Procedures: [https://www.usitc.gov/documents/handbook\\_on\\_filing\\_procedures.pdf](https://www.usitc.gov/documents/handbook_on_filing_procedures.pdf).

<sup>2</sup> All contract personnel will sign appropriate nondisclosure agreements.

<sup>3</sup> Electronic Document Information System (EDIS): <https://edis.usitc.gov>.

## INTERNATIONAL TRADE COMMISSION

[Investigation Nos. 701-TA-528-529 and 731-TA-1264-1268 (Review)]

### Uncoated Paper From Australia, Brazil, China, Indonesia, and Portugal

#### Determinations

On the basis of the record<sup>1</sup> developed in the subject five-year reviews, the United States International Trade Commission (“Commission”) determines, pursuant to the Tariff Act of 1930 (“the Act”), that revocation of the countervailing duty orders on uncoated paper from China and Indonesia and the antidumping duty orders on uncoated paper from Australia, Brazil, China, Indonesia, and Portugal would be likely to lead to continuation or recurrence of material injury to an industry in the United States within a reasonably foreseeable time.

#### Background

The Commission instituted these reviews on February 1, 2021 (86 FR 7734) and determined on May 7, 2021, that it would conduct full reviews (86 FR 27650, May 21, 2021). Notice of the scheduling of the Commission’s reviews and of a public hearing to be held in connection therewith was given by posting copies of the notice in the Office of the Secretary, U.S. International Trade Commission, Washington, DC, and by publishing the notice in the **Federal Register** on July 23, 2021 (86 FR 39057). The Commission conducted its hearing on November 18, 2021. All persons who requested the opportunity were permitted to participate.

The Commission made these determinations pursuant to section 751(c) of the Act (19 U.S.C. 1675(c)). It completed and filed its determinations in these reviews on January 31, 2022. The views of the Commission are contained in USITC Publication 5275 (January 2022), entitled *Uncoated Paper from Australia, Brazil, China, Indonesia, and Portugal: Investigation Nos. 701-TA-528-529 and 731-TA-1264-1268 (Review)*.

By order of the Commission.

Issued: January 31, 2022.

**Lisa Barton,**

Secretary to the Commission.

[FR Doc. 2022-02293 Filed 2-2-22; 8:45 am]

**BILLING CODE 7020-02-P**

<sup>1</sup> The record is defined in § 207.2(f) of the Commission’s Rules of Practice and Procedure (19 CFR 207.2(f)).

## DEPARTMENT OF JUSTICE

### Drug Enforcement Administration

[Docket No. DEA-372]

### Exempt Chemical Preparations Under the Controlled Substances Act

#### Correction

In Notice document 2022-01112 beginning on page 3335 in the issue of Friday, January 21, 2022, make the following correction:

On page 3343, beginning on the last line of the first column, “This Order is effective [insert Date Thirty Days from the Date of Publication in the **Federal Register**].” should read “This Order is effective February 22, 2022.”

[FR Doc. C1-2022-01112 Filed 2-2-22; 8:45 am]

**BILLING CODE 0099-10-D**

## DEPARTMENT OF LABOR

### Office of Workers’ Compensation Programs

#### Proposed Extension of Existing Collection; Comment Request

**AGENCY:** Division of Coal Mine Workers’ Compensation, Office of Workers’ Compensation Programs, Department of Labor.

**ACTION:** Notice.

**SUMMARY:** Currently, the Office of Workers’ Compensation Programs is soliciting comments concerning the proposed collection: Disclosure of Medical Evidence. A copy of the proposed information collection request can be obtained by contacting the office listed below in the addresses section of this Notice. This program helps to ensure that requested data can be provided in the desired format, reporting burden (time and financial resources) is minimized, collection instruments are clearly understood and the impact of collection requirements on respondents can be properly assessed.

**DATES:** Written comments must be submitted to the office listed in the address section below on or before April 4, 2022.

**ADDRESSES:** You may submit comments by mail, delivery service, or by hand to Ms. Anjanette Suggs, U.S. Department of Labor, 200 Constitution Avenue NW, Room S-3323, Washington, DC 20210; by fax to (202) 354-9660; or by Email to [Suggs.Anjanette@dol.gov](mailto:Suggs.Anjanette@dol.gov). Please use only one method of transmission for comments (mail/delivery, fax or Email). Please note that comments submitted after the comment period will not be considered.

**SUPPLEMENTARY INFORMATION:** The Department of Labor, as part of its continuing effort to reduce paperwork and respondent burden, conducts a pre-clearance consultation program to provide the general public and Federal agencies with an opportunity to comment on proposed and/or continuing collections of information in accordance with the Paperwork Reduction Act of 1995 (PRA95).

#### I. Background

The Department’s regulations implementing the Black Lung Benefits Act (BLBA), 30 U.S.C. 901 *et seq.*, may require parties to exchange all medical information about the miner they develop in connection with a claim for benefits, including information parties do not intend to submit as evidence in the claim. See 20 CFR 725.413. The rule helps protect a miner’s health, assist unrepresented parties, and promote accurate benefit determinations.

The potential parties to a BLBA claim include the benefits claimant, the responsible coal mine operator and its insurance carrier, and the Director, Office of Workers’ Compensation Programs (OWCP). Under this rule, a party of a party’s agent who receives medical information about the miner must send a copy to all other parties within 30 days after receipt or, if a hearing before an administrative law judge has already been scheduled, at least 20 days before the hearing. The exchanged information is entered into the record of the claim only if a party submits it into evidence.

The Department’s authority to engage in information collection is specified in BLBA sections 413(b), 422(2) and 426(a). see 30 U.S.C. 923(b), 932(a) and 936(a). This information collection is currently approved for use through July 31, 2022.

#### II. Review Focus

The Department of Labor is particularly interested in comments which:

- \* Evaluate whether the proposed collection of information is necessary for the proper performance of the functions of the agency, including whether the information will have practical utility;

- \* evaluate the accuracy of the agency’s estimate of the burden of the proposed collection of information, including the validity of the methodology and assumptions used;

- \* enhance the quality, utility and clarity of the information to be collected; and

- \* minimize the burden of the collection of information on those who

are to respond, including through the use of appropriate automated, electronic, mechanical, or other technological collection techniques or other forms of information technology, e.g., permitting electronic submissions of responses.

### III. Current Actions

The Department of Labor seeks approval for the extension of this currently-approved information collection. The collection is necessary to give miners full access to information about their health, assist unrepresented claimants, and reach accurate benefit determinations under the BLBA.

*Agency:* Office of Workers' Compensation Programs.

*Type of Review:* Extension.

*Title:* Disclosure of Medical Evidence.

*OMB Number:* 1240-0054.

*Affected Public:* Individuals or households.

*Total Respondents:* 6,105.

*Total Annual Responses:* 6,105.

*Average Time per Response:* 10 minutes.

*Estimated Total Burden Hours:* 1,018 hours.

*Frequency:* On occasion.

*Total Burden Cost (capital/startup):* \$0.

*Total Burden Cost (operating/maintenance):* \$8,659.

Comments submitted in response to this notice will be summarized and/or included in the request for Office of Management and Budget approval of the information collection request; they will also become a matter of public record.

#### Anjanette Suggs,

*Agency Clearance Officer, Office of Workers' Compensation Programs, U.S. Department of Labor.*

[FR Doc. 2022-02195 Filed 2-2-22; 8:45 am]

BILLING CODE 4510-CK-P

## NATIONAL AERONAUTICS AND SPACE ADMINISTRATION

[Notice: (22-009)]

### NASA Advisory Council; STEM Engagement Committee; Meeting

**AGENCY:** National Aeronautics and Space Administration.

**ACTION:** Notice of meeting.

**SUMMARY:** In accordance with the Federal Advisory Committee Act, Public Law 92-463, as amended, the National Aeronautics and Space Administration announces a meeting of the Science, Technology, Engineering and Mathematics (STEM) Engagement Committee of the NASA Advisory

Council (NAC). This Committee reports to the NAC.

**DATES:** Thursday, February 17, 2021, 1:00 p.m.–5:00 p.m., Eastern Time.

**ADDRESSES:** Virtual meeting by dial-in teleconference and WebEx only.

**FOR FURTHER INFORMATION CONTACT:** Dr. Beverly Girten, Designated Federal Officer, NAC STEM Engagement Committee, NASA Headquarters, Washington, DC 20546, (202) 358-0212, or *beverly.e.girten@nasa.gov*.

**SUPPLEMENTARY INFORMATION:** This meeting will be held virtually and will be available telephonically and by WebEx only. You must use a touch tone phone to participate in this meeting. Any interested person may dial the toll-free access number 415-527-5035, and then the access code 2763 189 1436 followed by the # sign. To join via WebEx, use link: <https://nasaenterprise.webex.com/nasaenterprise/onstage/g.php?MTID=e8c794ada9b86b843b5b6596863ecbdd6> with meeting number and access code 2763 189 1436 and password t2nNvj46M5\$ (Password is case sensitive.) NOTE: If dialing in, please "mute" your telephone. The agenda for the meeting will include the following:

- Opening Remarks by Chair
- STEM Engagement Update, Goals and Strategy
- Priorities for 2022
- Review Earlier Findings and Recommendations to the NASA Advisory Council
- Formulation of New Findings and Recommendations
- Other Related Topics

It is imperative that the meeting be held on this date to accommodate the scheduling priorities of the key participants.

#### Patricia Rausch,

*Advisory Committee Management Officer, National Aeronautics and Space Administration.*

[FR Doc. 2022-02207 Filed 2-2-22; 8:45 am]

BILLING CODE 7510-13-P

## NUCLEAR REGULATORY COMMISSION

[NRC-2021-0231]

### Guide for Assessing, Monitoring, and Mitigating Aging Effects on Electrical Equipment Used in Nuclear Power Generating Stations

**AGENCY:** Nuclear Regulatory Commission.

**ACTION:** Draft regulatory guide; request for comment.

**SUMMARY:** The U.S. Nuclear Regulatory Commission (NRC) is issuing for public comment a draft regulatory guide (DG), DG-1393, "Guide for Assessing, Monitoring, and Mitigating Aging Effects on Electrical Equipment Used in Nuclear Power Generating Stations." This proposed DG describes methods that are acceptable to the NRC staff to use for assessing, monitoring, and mitigating aging effects on electrical equipment used in nuclear power generating stations.

**DATES:** Submit comments by March 7, 2022. Comments received after this date will be considered if it is practical to do so, but the NRC is able to ensure consideration only for comments received on or before this date.

**ADDRESSES:** You may submit comments by any of the following methods; however, the NRC encourages electronic comment submission through the Federal rulemaking website:

- *Federal Rulemaking Website:* Go to <https://www.regulations.gov> and search for Docket ID NRC-2021-0231. Address questions about Docket IDs in *Regulations.gov* to Stacy Schumann; telephone: 301-415-0624; email: *Stacy.Schumann@nrc.gov*. For technical questions, contact the individuals listed in the **FOR FURTHER INFORMATION CONTACT** section of this document.
- *Mail comments to:* Office of Administration, Mail Stop: TWFN-7-A60M, U.S. Nuclear Regulatory Commission, Washington, DC 20555-0001, ATTN: Program Management, Announcements and Editing Staff.

For additional direction on obtaining information and submitting comments, see "Obtaining Information and Submitting Comments" in the **SUPPLEMENTARY INFORMATION** section of this document.

#### FOR FURTHER INFORMATION CONTACT:

Ronaldo Jenkins, telephone: 301-415-6978, email: *Ronaldo.Jenkins@nrc.gov*; Michael Eudy, telephone: 301-415-3104, email: *Michael.Eudy@nrc.gov*; and Mohammad Sadollah, telephone: 301-415-6804, email: *Mohammad.Sadollah@nrc.gov*. All are staff members of the Office of Nuclear Regulatory Research at the U.S. Nuclear Regulatory Commission, Washington, DC 20555-0001.

#### SUPPLEMENTARY INFORMATION:

### I. Obtaining Information and Submitting Comments

#### A. Obtaining Information

Please refer to Docket ID NRC-2021-0231 when contacting the NRC about the availability of information for this action. You may obtain publicly

available information related to this action by any of the following methods:

- *Federal Rulemaking Website*: Go to <https://www.regulations.gov> and search for Docket ID NRC-2021-0231.

- *NRC's Agencywide Documents Access and Management System (ADAMS)*: You may obtain publicly available documents online in the ADAMS Public Documents collection at <https://www.nrc.gov/reading-rm/adams.html>. To begin the search, select "Begin Web-based ADAMS Search." For problems with ADAMS, please contact the NRC's Public Document Room (PDR) reference staff at 1-800-397-4209, 301-415-4737, or by email to [PDR.Resource@nrc.gov](mailto:PDR.Resource@nrc.gov). DG-1393, "Guide for Assessing, Monitoring, and Mitigating Aging Effects on Electrical Equipment Used in Nuclear Power Generating Stations," is available in ADAMS under Accession No. ML21288A115. The staff is also issuing for public comment a draft regulatory analysis for DG-1393 under ADAMS Accession No. ML21288A112.

- *NRC's PDR*: You may examine and purchase copies of public documents, by appointment, at the NRC's PDR, Room P1 B35, One White Flint North, 11555 Rockville Pike, Rockville, Maryland 20852. To make an appointment to visit the PDR, please send an email to [PDR.Resource@nrc.gov](mailto:PDR.Resource@nrc.gov) or call 1-800-397-4209 or 301-415-4737, between 8:00 a.m. and 4:00 p.m. (ET), Monday through Friday, except Federal holidays.

#### B. Submitting Comments

The NRC encourages electronic comment submission through the Federal rulemaking website (<https://www.regulations.gov>). Please include Docket ID NRC-2021-0231 in your comment submission.

The NRC cautions you not to include identifying or contact information that you do not want to be publicly disclosed in your comment submission. The NRC will post all comment submissions at <https://www.regulations.gov> as well as enter the comment submissions into ADAMS.

The NRC does not routinely edit comment submissions to remove identifying or contact information.

If you are requesting or aggregating comments from other persons for submission to the NRC, then you should inform those persons not to include identifying or contact information that they do not want to be publicly disclosed in their comment submission. Your request should state that the NRC does not routinely edit comment submissions to remove such information before making the comment

submissions available to the public or entering the comment into ADAMS.

## II. Additional Information

The NRC is issuing for public comment a DG in the NRC's "Regulatory Guide" series. This series was developed to describe methods that are acceptable to the NRC staff for implementing specific parts of the agency's regulations, to explain techniques that the staff uses in evaluating specific issues or postulated events, and to describe information that the staff needs in its review of applications for permits and licenses.

The DG, entitled "Guide for Assessing, Monitoring, and Mitigating Aging Effects on Electrical Equipment Used in Nuclear Power Generating Stations," is a proposed new Regulatory Guide 1.248 and is being issued with a temporary identification of Draft Regulatory Guide, DG-1393.

Nuclear power plants (NPPs) licensed under Parts 50 and 52 of title 10 of the *Code of Federal Regulations* (10 CFR), are required to monitor the performance or condition of Structures, Systems and Components (SSCs) against licensee-established goals, in a manner sufficient to provide reasonable assurance that these SSCs can fulfill their intended functions. Further, applicants for and holders of NPP renewed licenses under 10 CFR part 54 are required to demonstrate that the effects of aging will be adequately managed for the period of extended operation. DG-1393 describes a method that the NRC staff considers acceptable in complying with NRC regulations for assessing, monitoring, and mitigating aging effects on electrical equipment in NPPs.

## III. Backfitting, Forward Fitting, and Issue Finality

Issuance of DG-1393, if finalized, would not constitute backfitting as that term is defined in 10 CFR 50.109, "Backfitting," and as described in NRC Management Directive (MD) 8.4, "Management of Backfitting, Forward Fitting, Issue Finality, and Information Requests"; would not constitute forward fitting as that term is defined and described in MD 8.4; and would not affect issue finality of any approval issued under 10 CFR part 52, "Licenses, Certificates, and Approvals for Nuclear Power Plants." As explained in DG-1393, applicants and licensees are not required to comply with the positions set forth in DG-1393.

Dated: January 31, 2022.

For the Nuclear Regulatory Commission.

**Meraj Rahimi,**

*Chief, Regulatory Guide and Programs Management Branch, Division of Engineering, Office of Nuclear Regulatory Research.*

[FR Doc. 2022-02267 Filed 2-2-22; 8:45 am]

**BILLING CODE 7590-01-P**

## POSTAL REGULATORY COMMISSION

[Docket Nos. MC2022-38 and CP2022-45]

### New Postal Products

**AGENCY:** Postal Regulatory Commission.  
**ACTION:** Notice.

**SUMMARY:** The Commission is noticing recent Postal Service filings for the Commission's consideration concerning negotiated service agreements. This notice informs the public of the filings, invites public comment, and takes other administrative steps.

**DATES:** *Comments are due:* February 7, 2022.

**ADDRESSES:** Submit comments electronically via the Commission's Filing Online system at <https://www.prc.gov>. Those who cannot submit comments electronically should contact the person identified in the **FOR FURTHER INFORMATION CONTACT** section by telephone for advice on filing alternatives.

**FOR FURTHER INFORMATION CONTACT:** David A. Trissell, General Counsel, at 202-789-6820.

#### SUPPLEMENTARY INFORMATION:

#### Table of Contents

- I. Introduction
- II. Docketed Proceeding(s)

### I. Introduction

The Commission gives notice that the Postal Service filed request(s) for the Commission to consider matters related to negotiated service agreement(s). The request(s) may propose the addition or removal of a negotiated service agreement from the market dominant or the competitive product list, or the modification of an existing product currently appearing on the market dominant or the competitive product list.

Section II identifies the docket number(s) associated with each Postal Service request, the title of each Postal Service request, the request's acceptance date, and the authority cited by the Postal Service for each request. For each request, the Commission appoints an officer of the Commission to represent the interests of the general public in the proceeding, pursuant to 39 U.S.C. 505 (Public Representative). Section II also

establishes comment deadline(s) pertaining to each request.

The public portions of the Postal Service's request(s) can be accessed via the Commission's website (<https://www.prc.gov>). Non-public portions of the Postal Service's request(s), if any, can be accessed through compliance with the requirements of 39 CFR 3011.301.<sup>1</sup>

The Commission invites comments on whether the Postal Service's request(s) in the captioned docket(s) are consistent with the policies of title 39. For request(s) that the Postal Service states concern market dominant product(s), applicable statutory and regulatory requirements include 39 U.S.C. 3622, 39 U.S.C. 3642, 39 CFR part 3030, and 39 CFR part 3040, subpart B. For request(s) that the Postal Service states concern competitive product(s), applicable statutory and regulatory requirements include 39 U.S.C. 3632, 39 U.S.C. 3633, 39 U.S.C. 3642, 39 CFR part 3035, and 39 CFR part 3040, subpart B. Comment deadline(s) for each request appear in section II.

## II. Docketed Proceeding(s)

1. *Docket No(s)*: MC2022–38 and CP2022–45; *Filing Title*: USPS Request to Add Priority Mail Contract 735 to Competitive Product List and Notice of Filing Materials Under Seal; *Filing Acceptance Date*: January 28, 2022; *Filing Authority*: 39 U.S.C. 3642, 39 CFR 3040.130 through 3040.135, and 39 CFR 3035.105; *Public Representative*: Kenneth R. Moeller; *Comments Due*: February 7, 2022.

This Notice will be published in the **Federal Register**.

**Erica A. Barker,**  
*Secretary.*

[FR Doc. 2022–02200 Filed 2–2–22; 8:45 am]

BILLING CODE 7710–FW–P

## SECURITIES AND EXCHANGE COMMISSION

[Release No. 34–94094; File No. SR–CboeBZX–2022–005]

### Self-Regulatory Organizations; Cboe BZX Exchange, Inc.; Notice of Filing and Immediate Effectiveness of Proposed Rule Change To List and Trade Shares of the Goldman Sachs Physical Gold ETF Under BZX Rule 14.11(e)(4) (Commodity-Based Trust Shares)

January 28, 2022.

Pursuant to Section 19(b)(1) of the Securities Exchange Act of 1934 (“Act”),<sup>1</sup> and Rule 19b–4 thereunder,<sup>2</sup> notice is hereby given that on January 25, 2022, Cboe BZX Exchange, Inc. filed with the Securities and Exchange Commission (“Commission”) the proposed rule change as described in Items I and II below, which Items have been substantially prepared by the Exchange. The Commission is publishing this notice to solicit comments on the proposed rule change from interested persons.

#### I. Self-Regulatory Organization's Statement of the Terms of Substance of the Proposed Rule Change

Cboe BZX Exchange, Inc. (the “Exchange” or “BZX”) is filing with the Securities and Exchange Commission (“Commission” or the “SEC”) a proposed rule change to list and trade shares of the Goldman Sachs Physical Gold ETF (the “Trust”) under BZX Rule 14.11(e)(4), Commodity-Based Trust Shares.

The text of the proposed rule change is also available on the Exchange's website ([http://markets.cboe.com/us/equities/regulation/rule\\_filings/bzx/](http://markets.cboe.com/us/equities/regulation/rule_filings/bzx/)), at the Exchange's Office of the Secretary, and at the Commission's Public Reference Room.

#### II. Self-Regulatory Organization's Statement of the Purpose of, and Statutory Basis for, the Proposed Rule Change

In its filing with the Commission, the Exchange included statements concerning the purpose of and basis for the proposed rule change and discussed any comments it received on the proposed rule change. The text of these statements may be examined at the places specified in Item IV below. The Exchange has prepared summaries, set forth in sections A, B, and C below, of the most significant aspects of such statements.

#### A. Self-Regulatory Organization's Statement of the Purpose of, and Statutory Basis for, the Proposed Rule Change

##### 1. Purpose

The Exchange proposes to list and trade the Shares under BZX Rule 14.11(e)(4),<sup>3</sup> which governs the listing and trading of Commodity-Based Trust Shares on the Exchange.<sup>4</sup> The Commission has previously approved and noticed for immediate and effective proposals that are substantively identical to this proposal that permit the listing and trading of the Shares on NYSE Arca, Inc. (“Arca”).<sup>5</sup> Further, the Shares are currently listed and traded on Arca and as of December 14, 2021 and had net assets of \$414.19 million.

Goldman Sachs Asset Management, L.P. is the sponsor of the Trust (the “Sponsor”). The Bank of New York Mellon is the trustee of the Trust (the “Trustee”). JPMorgan Chase Bank, N.A., London branch serves as the custodian of the Trust's gold bullion (the “Custodian”) and is responsible for the safekeeping of the gold owned by the Trust. The Shares are registered with the Commission by means of the Trust's registration statement on Form S–3 (the “Registration Statement”).<sup>6</sup>

<sup>3</sup> The Commission approved BZX Rule 14.11(e)(4) in Securities Exchange Act Release No. 65225 (August 30, 2011), 76 FR 55148 (September 6, 2011) (SR–BATS–2011–018).

<sup>4</sup> All statements and representations made in this filing regarding (a) the description of the portfolio, (b) limitations on portfolio holdings, or (c) the applicability of Exchange rules and surveillance procedures shall constitute continued listing requirements for listing the Shares on the Exchange.

<sup>5</sup> See Securities Exchange Act No. 82372 (December 21, 2017), 82 FR 61601 (December 28, 2017) (SR–NYSEArca–2017–140) (the “Original Proposal”). See also Securities Exchange Act No. 82593 (January 26, 2018), 83 FR 4718 (February 1, 2018) (SR–NYSEArca–2017–140) (Order Approving the Original Proposal). The order approving the Original Proposal was later amended on November 20, 2020 to reflect (i) a change in the sponsors and the custodian of the Perth Mint Physical Gold ETF, which was renamed as the Goldman Sachs Physical Gold ETF, (ii) the elimination of an investor's ability to take delivery of Physical Gold, and (iii) in connection with the change of custodian, the removal of the Government Guarantee, and to amend certain other representations in the Proposal. See Securities Exchange Act No. 90529 (November 30, 2020), 85 FR 78391 (December 4, 2020) (SR–NYSEArca–2020–100) (the “Updated Proposal”).

<sup>6</sup> On June 11, 2019 the Trust filed with the Commission a registration statement on Form S–1 under the Securities Act of 1933 relating to the Trust (File No. 333–224389) (“S–1 Registration Statement”). The S–1 Registration Statement was declared effective by the SEC on June 20, 2019. On December 28, 2020, the Trust filed with the Commission the Registration Statement on Form S–3 under the Securities Act of 1933 relating to the Trust (File No. 333–251769). The Registration Statement was declared effective by the SEC on January 8, 2021.

<sup>1</sup> See Docket No. RM2018–3, Order Adopting Final Rules Relating to Non-Public Information, June 27, 2018, Attachment A at 19–22 (Order No. 4679).

<sup>1</sup> 15 U.S.C. 78s(b)(1).

<sup>2</sup> 17 CFR 240.19b–4.

The Trust will not be registered as an investment company under the Investment Company Act of 1940, as amended,<sup>7</sup> and is not required to register under such act. The Trust is not a commodity pool for purposes of the Commodity Exchange Act, as amended.<sup>8</sup>

#### Goldman Sachs Physical Gold ETF

The Trust's primary objective is for the Shares to reflect the performance of the price of gold less the expenses of the Trust's operations. Although the Shares are not the exact equivalent of an investment in gold, they provide investors with an alternative that allows a level of participation in the gold market through the securities market.

#### Operation of the Gold Market

The global trade in gold consists of over-the-counter ("OTC") transactions in spot, forwards, and options and other derivatives, together with exchange-traded futures and options. The OTC market trades on a continuous basis and accounts for most global gold trading. Market makers and participants in the OTC market trade with each other and their clients on a principal-to-principal basis. The main centers of the OTC market are London, New York and Zurich. Most OTC market trades are cleared through London. The London Bullion Market Association ("LBMA") plays an important role in setting OTC gold trading industry standards.

#### Futures Exchanges

Although the Trust will not invest in gold futures, information about the gold futures market is relevant as such markets contribute to, and provide evidence of, the liquidity of the overall market for gold. The most significant gold futures exchange in the U.S. is COMEX, operated by Commodities Exchange, Inc., a subsidiary of New York Mercantile Exchange, Inc., and a subsidiary of the Chicago Mercantile Exchange Group (the "CME Group"). Other commodity exchanges include the Tokyo Commodity Exchange ("TOCOM"), the Multi Commodity Exchange Of India ("MCX"), the Shanghai Futures Exchange, ICE Futures US (the "ICE"), and the Dubai Gold & Commodities Exchange.<sup>9</sup>

#### The London Bullion Market Association

The LBMA is a trade association that, among other duties, maintains and publishes "Good Delivery" lists that establish a set of criteria that a refiner and its gold must satisfy before being

accepted for trading. Although the market for Physical Gold<sup>10</sup> is distributed globally, most OTC market trades are cleared through London. The LBMA coordinates the market for gold and acts as the principal point of contact between the market and its regulators. A primary function of the LBMA is its involvement in the promotion of refining standards by maintenance of the "London Good Delivery Lists," which are the lists of LBMA accredited melters and assayers of gold as well as the specifications to which a bar/ingot must adhere. The LBMA also coordinates market clearing and vaulting, and promotes good trading practices. "Good Delivery" is a list of specifications a bar or ingot must meet to trade on the London gold markets. The standards for gold bars meeting the "London Good Delivery Lists" are published in LBMA's "The Good Delivery Rules for Gold and Silver Bars". Gold is usually traded on the London market on a loco London basis. This means the gold is physically held in vaults in London or is transferred into accounts established in London. Payment upon settlement and delivery of a loco London spot trade is usually in U.S. dollars, two business days after the trade date. Delivery of the gold is either by physical delivery or through the LBMA clearing system to an unallocated account.

#### Creation and Redemption of Shares by Authorized Participants

According to the Registration Statement, authorized participants may purchase (*i.e.*, create) or redeem Shares only in blocks of 25,000 Shares (each such block, a "Creation Unit") in the Trust. Creation Units are offered to authorized participants at the Trust's net asset value ("NAV"). The size of a Creation Unit is subject to change. The creation and redemption of Creation Units will only be made in exchange for the delivery to the Trust or the distribution by the Trust of the amount of gold represented by the Creation Units being created or redeemed, the amount of which will be based on the combined Fine Ounces<sup>11</sup> represented by the number of Shares included in the Creation Units being created or

redeemed determined on the day the order to create or redeem Creation Units is properly received.

Orders to create and redeem Creation Units may be placed only by authorized participants. An authorized participant must: (1) Be a registered broker-dealer or other securities market participant, such as a bank or other financial institution, which, but for an exclusion from registration, would be required to register as a broker-dealer to engage in securities transactions, (2) be a participant in the Depository Trust Company ("DTC") and (3) must have an agreement with the Custodian establishing an account or have an existing account meeting the standards described herein.

Gold is delivered to the Trust and distributed by the Trust through credits and debits between authorized participants' accounts, the trust unallocated metal account and the trust allocated metal account. When the Trustee requests creation of a basket at an authorized participant's request, the authorized participant will then transfer gold to the trust unallocated metal account. Once that gold is received in the trust unallocated metal account, the Custodian will then allocate the gold to the trust allocated metal account where it will be stored for safekeeping. All gold represented by a credit to any authorized participant's unallocated account represents a right to receive Fine Ounces of gold. London Bars must further conform to London Good Delivery Standards.

#### Creation Procedures—Authorized Participants

On any business day, an authorized participant may place an order with the Trustee to create one or more Creation Unit. For purposes of processing both purchase and redemption orders, a "business day" means any day other than a day: (1) When the Exchange is closed for regular trading; or (2) if the order or other transaction requires the receipt or delivery, or the confirmation of receipt or delivery, of gold in the United Kingdom, or in some other jurisdiction on a particular day, (A) when banks are authorized to close in the United Kingdom, or in such other jurisdiction or when the London gold market is closed or (B) when banks in the United Kingdom, or in such other jurisdiction are, or the London gold market is, not open for a full business day and the order or other transaction requires the execution or completion of procedures which cannot be executed or completed by the close of the business day. Purchase orders must be placed

<sup>10</sup> "Physical Gold" means gold bullion that meets the London Good Delivery Standards.

<sup>11</sup> "Fine Ounce" means an ounce of 100% pure gold, Fine Ounces being determined, as to Physical Gold, by multiplying the gross weight in ounces by the fineness, expressed as a fraction of the fine metal content in parts per 1,000 in accordance with London Good Delivery Standards and, as to gold held on an unallocated basis, by the number of Fine Ounces credited to the applicable unallocated account from time to time (such account being denominated in Fine Ounces).

<sup>7</sup> 15 U.S.C. 80a-1.

<sup>8</sup> 17 U.S.C. 1.

<sup>9</sup> The CME Group and the ICE are members of the Intermarket Surveillance Group ("ISG").

prior to the Order Cutoff Time<sup>12</sup> on any business day.

#### Determination of Required Deposits

The Trustee shall determine the Basket Gold Amount<sup>13</sup> for each business day, and each such determination thereof and the Trustee's resolution of questions concerning the composition of the Basket Gold Amount shall be final and binding on all persons interested in the Trust. At the creation of the Trust, the initial Basket Gold Amount was 500 Fine Ounces of gold. After the initial deposit of gold into the Trust, the Creation Unit Gold Amount for each business day shall be an amount of gold equal to:

$$\frac{(a) \text{ minus } (b)}{(c) \text{ divided by } (d)}$$

Where:

- (a) = the total number of Fine Ounces of gold held in the Trust as of the opening of business on such business day
- (b) = the number of Fine Ounces of gold equal in value to the Trust's unpaid expense accrual as of the opening of business on such business day
- (c) = the total number of Shares outstanding as of the opening of business on such business day
- (d) = 25,000 (or other number of Shares in a Creation Unit for such business day). Fractions of a Fine Ounce of gold included in the Basket Gold Amount smaller than 0.001 Fine Ounces shall be disregarded. The Sponsor shall publish, or shall designate another person to publish, for each business day, the Basket Gold Amount

#### Delivery of Required Deposits

An authorized participant who places a purchase order is responsible for crediting the trust unallocated metal account with the required gold deposit amount by 4:00 p.m. London time on the second business day following the purchase order date. No Shares will be issued unless and until the Custodian has informed the Trustee that it has credited to the trust allocated metal account at the Custodian the corresponding amount of gold. Upon transfer of the gold deposit amount to the trust allocated metal account, the Trustee will direct DTC to credit the number of Creation Units ordered to the authorized participant's DTC account.

<sup>12</sup> "Order Cutoff Time" is defined, with respect to any business day, as (i) 3:59:59 p.m. New York City time on such business day or (ii) another time agreed to by the Sponsors and the Trustee as to which the Sponsor has notified registered owners of Shares and all existing authorized participants.

<sup>13</sup> "Basket Gold Amount" refers to the amount of gold that must be deposited for issuance of one Creation Unit or that is deliverable on surrender of one Creation Unit.

The expense and risk of delivery, ownership and safekeeping of gold, until such gold has been received by the Custodian on behalf of the Trust, shall be borne solely by the authorized participant.

#### Redemption Procedures—Authorized Participants

The procedures by which an authorized participant can redeem one or more Creation Unit will mirror the procedures for the creation of Creation Units. On any business day, an authorized participant may place an order with the Trustee to redeem one or more Creation Units. Redemption orders must be placed prior to the Order Cutoff Time on each business day the Exchange is open for regular trading (normally 9:30 a.m. Eastern Time). A redemption order so received is effective on the date it is received in satisfactory form by the Trustee. The redemption procedures allow only authorized participants to redeem Creation Units. An investor may not redeem Creation Units other than through an authorized participant. By placing a redemption order, an authorized participant agrees to deliver the Creation Unit to be redeemed through DTC's book-entry system to the Trust no later than the second business day following the effective date of the redemption order. Prior to the delivery of the redemption distribution for a redemption order, the authorized participant must also have wired to the Trustee the non-refundable transaction fee due for the redemption order. The redemption distribution from the Trust consists of a credit to the redeeming authorized participant's account representing the amount of the gold held by the Trust evidenced by the Shares being redeemed as of the date of the redemption order. A redeeming authorized participant is responsible for any applicable tax, fees or other governmental charge that may be due, as well as any charges or fees in connection with the transfer of gold and the issuance and delivery of the Shares, and any expense associated with the delivery of gold other than by credit to an authorized participant's unallocated account with the Custodian or another LBMA-member clearing bank.

#### Delivery of Redemption Distribution

The redemption distribution due from the Trust is delivered to the authorized participant on the second business day following the redemption order date if, by 9:00 a.m. Eastern time on the second business day following the redemption order date, the Trustee's DTC account has been credited with the Creation

Units to be redeemed. The Custodian will arrange for the redemption amount in gold to be transferred from the trust allocated metal account to the trust unallocated metal account, and thereafter, as necessary, to the redeeming authorized participant's account. With respect to a redemption order provided in the ordinary course, the Custodian shall deliver unallocated gold to the account indicated by the redeeming authorized participant in its redemption order by 4:00 p.m. London Time on the second business day following the order date.

#### Valuation of Gold and Computation of NAV

On each business day that the Exchange is open for regular trading, as promptly as practicable after 4:00 p.m., Eastern time, the Trustee will value the gold held by the Trust and will determine the NAV of the Trust, as described below. The NAV of the Trust is the aggregate value of gold and other assets, if any, of the Trust (other than any amounts credited to the Trust's reserve account, if any) including cash, if any, less liabilities of the Trust, which include estimated accrued but unpaid fees, expenses and other liabilities. All gold is valued based on its Fine Ounce content, calculated by multiplying the weight of gold by its purity; the same methodology is applied independent of the type of gold held by the Trust. The Trustee values the gold held by the Trust based on the afternoon LBMA Gold Price, or the morning LBMA Gold Price, if such day's afternoon LBMA Gold Price is not available. If no LBMA Gold Price is available for the day, the Trustee will value the Trust's gold based on the most recently announced afternoon LBMA Gold Price or morning LBMA Gold Price. If the Sponsor determines that such price is inappropriate to use, it shall identify an alternate basis for evaluation to be employed by the Trustee. The Sponsor may instruct the Trustee to use a different price which is reasonably available to the Trustee at no cost to the Trustee that the Sponsor determines to fairly represent the commercial value of the Trust's gold. Once the value of gold has been determined, the Trustee will subtract all estimated accrued but unpaid fees, expenses and other liabilities of the Trust from the total value of gold and any other assets of the Trust (other than any amounts credited to the Trust's reserve account), including cash, if any. The resulting figure is the NAV of the Trust. The Trustee will also determine the NAV per share by dividing the NAV of the Trust by the number of the Shares outstanding

as of the close of trading on the Exchange (which includes the net number of any Shares deemed created or redeemed on such evaluation day).<sup>14</sup>

#### Secondary Market Trading

The Shares may trade in the secondary market on the Exchange at prices that are lower or higher relative to their NAV per share. The amount of the discount or premium in the trading price relative to the NAV per share may be influenced by non-concurrent trading hours between the Exchange and the COMEX, London and Zurich. While the Shares will trade on the Exchange during all trading sessions, liquidity in the global gold market may be reduced after the close of the major world gold markets, including London, Zurich and COMEX, usually at 1:30 p.m. Eastern Time. As a result, during this time, trading spreads and the resulting premium or discount on the Shares may widen.

#### Availability of Information Regarding Gold

Currently, the Consolidated Tape Plan does not provide for dissemination of the spot price of a commodity such as gold over the Consolidated Tape. However, there will be disseminated over the Consolidated Tape the last sale price for the Shares, as is the case for all equity securities traded on the Exchange (including exchange-traded funds). In addition, there is a considerable amount of information about gold and gold markets available on public websites and through professional and subscription services. Investors may obtain gold pricing information on a 24-hour basis based on the spot price for an ounce of gold from various financial information service providers, such as Reuters and Bloomberg. Reuters and Bloomberg, for example, provide at no charge on their websites delayed information regarding the spot price of Gold and last sale prices of Gold futures, as well as information about news and developments in the gold market. Reuters and Bloomberg also offer a professional service to subscribers for a fee that provides information on Gold prices directly from market participants.

Complete real-time data for Gold futures and options prices traded on the COMEX are available by subscription from Reuters and Bloomberg. There are a variety of other public websites providing information on gold, ranging

from those specializing in precious metals to sites maintained by major newspapers. In addition, the LBMA Gold Price is publicly available at no charge at [www.lbma.org.uk](http://www.lbma.org.uk).

Investors may obtain gold pricing information based on the spot price for a Fine Ounce from various financial information service providers. Current spot prices also are generally available with bid/ask spreads from gold bullion dealers. In addition, the Trust's website will provide pricing information for gold spot prices and the Shares. Market prices for the Shares will be available from a variety of sources including brokerage firms, information websites and other information service providers. The NAV of the Trust will be published by the Sponsor on each day that the Exchange is open for regular trading and will be posted on the Trust's website.

#### Intraday Indicative Value ("IIV")

The IIV is an indicator of the value of the Trust's net assets at the time the IIV is disseminated. The IIV is calculated and disseminated every 15 seconds during Regular Trading Hours.<sup>15</sup> The IIV is generally calculated using the prior day's closing net assets of the Trust as a base and updating throughout the trading day changes in the value of the gold and cash held by the Trust.

The IIV will be disseminated by the Exchange or a major market data vendor. In addition, the IIV is available through on-line information services such as Bloomberg Finance L.P. and Reuters.

#### Availability of Information

The Trust's website, Goldman Sachs Physical Gold ETF ([www.gsam.com](http://www.gsam.com)), which is publicly accessible at no charge, contains the following information: (a) The prior business day's NAV per Share, the reported daily closing price and the reported daily trading volume; (b) the Basket Gold Amount; (c) the midpoint of the bid-ask price as of the time the NAV per Share is calculated (the "Bid-Ask Price"); (d) the calculation of the premium or discount of such price against such NAV per Share; (e) data in chart form displaying the frequency distribution of discounts or premiums of the bid-ask price against the NAV per Share, within appropriate ranges for each of the four previous calendar quarters; and (f) the current prospectus of the Trust.<sup>16</sup> Finally, the Trust's website will provide

the last sale price of the Shares as traded in the U.S. market. In addition, information regarding market price and trading volume of the Shares will be continually available on a real-time basis throughout the day on brokers' computer screens and other electronic services. Information regarding the previous day's closing price and trading volume information for the Shares will be published daily in the financial section of newspapers.

#### Criteria for Initial and Continued Listing

The Trust will be subject to the criteria in Rule 14.11(e)(4) for initial and continued listing of the Shares. The Exchange will obtain a representation that the Trust's NAV will be calculated daily and that these values and information about the assets of the Trust will be made available to all market participants at the same time. The Exchange notes that, as defined in Rule 14.11(e)(4)(C)(i), the Shares will be: (a) Issued by a trust that holds a specified commodity<sup>17</sup> deposited with the trust; (b) issued by such trust in a specified aggregate minimum number in return for a deposit of a quantity of the underlying commodity; and (c) when aggregated in the same specified minimum number, may be redeemed at a holder's request by such trust which will deliver to the redeeming holder the quantity of the underlying commodity. Upon termination of the Trust, the Shares will be removed from listing. The Trustee, Bank of New York Mellon, is a trust company having substantial capital and surplus and the experience and facilities for handling corporate trust business, as required under Rule 14.11(e)(4)(E)(iv)(a) and that no change will be made to the trustee without prior notice to and approval of the Exchange.

#### Trading Halts

With respect to trading halts, the Exchange may consider all relevant factors in exercising its discretion to halt or suspend trading in the Shares. The Exchange will halt trading in the Shares under the conditions specified in BZX Rule 11.18. Trading may be halted because of market conditions or for reasons that, in the view of the Exchange, make trading in the Shares inadvisable. These may include: (1) The extent to which trading is not occurring in underlying gold market; or (2) whether other unusual conditions or circumstances detrimental to the maintenance of a fair and orderly market are present. Trading in the

<sup>14</sup> The exchange of Shares to facilitate the delivery of Physical Gold is subject to applicable product premiums and the delivery fees associated with the transport of Physical Gold to delivery applicants.

<sup>15</sup> Regular Trading Hours is the time between 9:30 a.m. and 4:00 p.m. Eastern Time.

<sup>16</sup> See <https://www.gsam.com/content/gsam/us/en/individual/products/etf-fund-finder/goldman-sachs-physical-gold-etf.html#activeTab=performance>.

<sup>17</sup> For purposes of Rule 14.11(e)(4), the term commodity takes on the definition of the term as provided in the Commodity Exchange Act.



Shares also will be subject to Rule 14.11(e)(4)(E)(ii), which sets forth circumstances under which trading in the Shares may be halted.

#### Trading Rules

The Exchange deems the Shares to be equity securities, thus rendering trading in the Shares subject to the Exchange's existing rules governing the trading of equity securities. BZX will allow trading in the Shares during all trading sessions on the Exchange. The Exchange has appropriate rules to facilitate transactions in the Shares during all trading sessions. As provided in BZX Rule 11.11(a), the minimum price variation for quoting and entry of orders in securities traded on the Exchange is \$0.01 where the price is greater than \$1.00 per share or \$0.0001 where the price is less than \$1.00 per share.

#### Surveillance

The Exchange believes that its surveillance procedures are adequate to properly monitor the trading of the Shares on the Exchange during all trading sessions and to deter and detect violations of Exchange rules and the applicable federal securities laws. Trading of the Shares through the Exchange will be subject to the Exchange's surveillance procedures for derivative products, including Commodity-Based Trust Shares. The issuer has represented to the Exchange that it will advise the Exchange of any failure by the Trust or the Shares to comply with the continued listing requirements, and, pursuant to its obligations under Section 19(g)(1) of the Act, the Exchange will surveil for compliance with the continued listing requirements. If the Trust or the Shares are not in compliance with the applicable listing requirements, the Exchange will commence delisting procedures under Exchange Rule 14.12. The Exchange may obtain information regarding trading in the Shares and Gold futures via ISG, from other exchanges who are members or affiliates of the ISG, or with which the Exchange has entered into a comprehensive surveillance sharing agreement.<sup>18</sup>

#### Information Circular

Prior to the commencement of trading, the Exchange will inform its members in an Information Circular of the special characteristics and risks associated with trading the Shares. Specifically, the Information Circular will discuss the following: (i) The

procedures for the creation and redemption of Baskets (and that the Shares are not individually redeemable); (ii) BZX Rule 3.7, which imposes suitability obligations on Exchange members with respect to recommending transactions in the Shares to customers; (iii) how information regarding the IIV and the Trust's NAV are disseminated; (iv) the risks involved in trading the Shares outside of Regular Trading Hours when an updated IIV will not be calculated or publicly disseminated; (v) the requirement that members deliver a prospectus to investors purchasing newly issued Shares prior to or concurrently with the confirmation of a transaction; and (vi) trading information. In addition, the Information Circular will advise members, prior to the commencement of trading, of the prospectus delivery requirements applicable to the Shares. Members purchasing the Shares for resale to investors will deliver a prospectus to such investors. The Information Circular will also discuss any exemptive, no-action and interpretive relief granted by the Commission from any rules under the Act.

#### 2. Statutory Basis

The Exchange believes that the proposal is consistent with Section 6(b) of the Act<sup>19</sup> in general and Section 6(b)(5) of the Act<sup>20</sup> in particular in that it is designed to prevent fraudulent and manipulative acts and practices, to promote just and equitable principles of trade, to foster cooperation and coordination with persons engaged in facilitating transactions in securities, to remove impediments to and perfect the mechanism of a free and open market and a national market system and, in general, to protect investors and the public interest.

The Commission has approved numerous series of Trust Issued Receipts, including Commodity-Based Trust Shares, to be listed on U.S. national securities exchanges. In order for any proposed rule change from an exchange to be approved, the Commission must determine that, among other things, the proposal is consistent with the requirements of Section 6(b)(5) of the Act, specifically including: (i) The requirement that a national securities exchange's rules are designed to prevent fraudulent and manipulative acts and practices; and (ii) the requirement that an exchange

proposal be designed, in general, to protect investors and the public interest.

The Exchange believes that the proposed rule change is designed to prevent fraudulent and manipulative acts and practices in that the Shares will be listed and traded on the Exchange pursuant to the initial and continued listing criteria in Exchange Rule 14.11(e)(4). The Exchange has in place surveillance procedures that are adequate to properly monitor trading in the Shares in all trading sessions and to deter and detect violations of Exchange rules and applicable federal securities laws. The Exchange may obtain information via ISG from other exchanges that are members of ISG or with which the Exchange has entered into a comprehensive surveillance sharing agreement.

The proposed rule change is designed to perfect the mechanism of a free and open market and, in general, to protect investors and the public interest in that it will facilitate the listing and trading of an additional type of exchange-traded product that will enhance competition among market participants, to the benefit of investors and the marketplace. As noted above, the Exchange has in place surveillance procedures relating to trading in the Shares and may obtain information via ISG from other exchanges that are members of ISG or with which the Exchange has entered into a comprehensive surveillance sharing agreement.

As noted above, the Commission has previously approved the Original Proposal, which considered together with the Updated Proposal is substantively identical to this proposal which permits the listing and trading of the Shares.

For the above reasons, the Exchange believes that the proposed rule change is consistent with the requirements of Section 6(b)(5) of the Act.

#### *B. Self-Regulatory Organization's Statement on Burden on Competition*

The Exchange does not believe that the proposed rule change will impose any burden on competition that is not necessary or appropriate in furtherance of the purpose of the Act. The Exchange believes that the proposed amendment will facilitate the listing of an additional exchange-traded product on the Exchange, which will enhance competition among listing venues, to the benefit of issuers, investors, and the marketplace more broadly.

<sup>18</sup> For a list of the current members and affiliate members of ISG, see [www.isgportal.com](http://www.isgportal.com).

<sup>19</sup> 15 U.S.C. 78f.

<sup>20</sup> 15 U.S.C. 78f(b)(5).

*C. Self-Regulatory Organization's Statement on Comments on the Proposed Rule Change Received From Members, Participants, or Others*

The Exchange has neither solicited nor received written comments on the proposed rule change.

**III. Date of Effectiveness of the Proposed Rule Change and Timing for Commission Action**

Because the foregoing proposed rule change does not: (i) Significantly affect the protection of investors or the public interest; (ii) impose any significant burden on competition; and (iii) become operative for 30 days from the date on which it was filed, or such shorter time as the Commission may designate, it has become effective pursuant to Section 19(b)(3)(A) of the Act<sup>21</sup> and Rule 19b-4(f)(6)<sup>22</sup> thereunder.<sup>23</sup>

A proposed rule change filed under Rule 19b-4(f)(6)<sup>24</sup> normally does not become operative prior to 30 days after the date of the filing. However, pursuant to Rule 19b-4(f)(6)(iii),<sup>25</sup> the Commission may designate a shorter time if such action is consistent with the protection of investors and the public interest. The Exchange has asked the Commission to waive the 30-day operative delay so that the proposed rule change may take effect upon filing and BZX may list the Shares as soon as practicable. The Commission believes that waiver of the 30-day operative delay is consistent with the protection of investors and the public interest because the proposed rule change does not raise any new or novel issues. Accordingly, the Commission waives the 30-day operative delay and designates the proposal operative upon filing.<sup>26</sup>

At any time within 60 days of the filing of the proposed rule change, the Commission summarily may temporarily suspend such rule change if it appears to the Commission that such action is necessary or appropriate in the public interest, for the protection of investors, or otherwise in furtherance of

the purposes of the Act. If the Commission takes such action, the Commission shall institute proceedings to determine whether the proposed rule change should be approved or disapproved.

**IV. Solicitation of Comments**

Interested persons are invited to submit written data, views, and arguments concerning the foregoing, including whether the proposed rule change is consistent with the Act. Comments may be submitted by any of the following methods:

*Electronic Comments*

- Use the Commission's internet comment form (<http://www.sec.gov/rules/sro.shtml>); or
- Send an email to [rule-comments@sec.gov](mailto:rule-comments@sec.gov). Please include File Number SR-CboeBZX-2022-005 on the subject line.

*Paper Comments*

- Send paper comments in triplicate to Secretary, Securities and Exchange Commission, 100 F Street NE, Washington, DC 20549-1090.

All submissions should refer to File Number SR-CboeBZX-2022-005. This file number should be included on the subject line if email is used. To help the Commission process and review your comments more efficiently, please use only one method. The Commission will post all comments on the Commission's internet website (<http://www.sec.gov/rules/sro.shtml>). Copies of the submission, all subsequent amendments, all written statements with respect to the proposed rule change that are filed with the Commission, and all written communications relating to the proposed rule change between the Commission and any person, other than those that may be withheld from the public in accordance with the provisions of 5 U.S.C. 552, will be available for website viewing and printing in the Commission's Public Reference Room, 100 F Street NE, Washington, DC 20549 on official business days between the hours of 10:00 a.m. and 3:00 p.m. Copies of the filing also will be available for inspection and copying at the principal office of the Exchange. All comments received will be posted without change. Persons submitting comments are cautioned that we do not redact or edit personal identifying information from comment submissions. You should submit only information that you wish to make available publicly. All submissions should refer to File Number SR-CboeBZX-2022-005 and

should be submitted on or before February 24, 2022.

For the Commission, by the Division of Trading and Markets, pursuant to delegated authority.<sup>27</sup>

**J. Matthew DeLesDernier,**

*Assistant Secretary.*

[FR Doc. 2022-02182 Filed 2-2-22; 8:45 am]

BILLING CODE 8011-01-P

**SECURITIES AND EXCHANGE COMMISSION**

**[Investment Company Act Release No. 34488]**

**Notice of Applications for Deregistration Under Section 8(f) of the Investment Company Act of 1940**

January 28, 2022.

The following is a notice of applications for deregistration under section 8(f) of the Investment Company Act of 1940 for the month of January 2022. A copy of each application may be obtained via the Commission's website by searching for the file number, or for an applicant using the Company name box, at <http://www.sec.gov/search/search.htm> or by calling (202) 551-8090. An order granting each application will be issued unless the SEC orders a hearing. Interested persons may request a hearing on any application by emailing the SEC's Secretary at [Secretarys-Office@sec.gov](mailto:Secretarys-Office@sec.gov) and serving the relevant applicant with a copy of the request by email, if an email address is listed for the relevant applicant below, or personally or by mail, if a physical address is listed for the relevant applicant below. Hearing requests should be received by the SEC by 5:30 p.m. on February 22, 2022, and should be accompanied by proof of service on applicants, in the form of an affidavit or, for lawyers, a certificate of service. Pursuant to Rule 0-5 under the Act, hearing requests should state the nature of the writer's interest, any facts bearing upon the desirability of a hearing on the matter, the reason for the request, and the issues contested. Persons who wish to be notified of a hearing may request notification by writing to the Commission's Secretary at [Secretarys-Office@sec.gov](mailto:Secretarys-Office@sec.gov).

**ADDRESSES:** The Commission: [Secretarys-Office@sec.gov](mailto:Secretarys-Office@sec.gov).

**FOR FURTHER INFORMATION CONTACT:** Shawn Davis, Assistant Director, at (202) 551-6413 or Chief Counsel's Office at (202) 551-6821; SEC, Division of Investment Management, Chief

<sup>27</sup> 17 CFR 200.30-3(a)(12).

<sup>21</sup> 15 U.S.C. 78s(b)(3)(A).

<sup>22</sup> 17 CFR 240.19b-4(f)(6).

<sup>23</sup> 17 CFR 240.19b-4(f)(6). In addition, Rule 19b-4(f)(6)(iii) requires a self-regulatory organization to give the Commission written notice of its intent to file the proposed rule change, along with a brief description and text of the proposed rule change, at least five business days prior to the date of filing of the proposed rule change, or such shorter time as designated by the Commission. The Exchange satisfied this requirement.

<sup>24</sup> 17 CFR 240.19b-4(f)(6).

<sup>25</sup> 17 CFR 240.19b-4(f)(6)(iii).

<sup>26</sup> For purposes only of waiving the 30-day operative delay, the Commission has considered the proposed rule's impact on efficiency, competition, and capital formation. See 15 U.S.C. 78c(f).

Counsel's Office, 100 F Street NE, Washington, DC 20549-8010.

**Calvert High Income Term Trust [File No. 811-23587]**

*Summary:* Applicant, a closed-end investment company, seeks an order declaring that it has ceased to be an investment company. Applicant has never made a public offering of its securities and does not propose to make a public offering or engage in business of any kind.

*Filing Date:* The application was filed on October 29, 2021.

*Applicant's Address:* [jbeksha@eatonvance.com](mailto:jbeksha@eatonvance.com).

**Cascades Trust [File No. 811-04626]**

*Summary:* Applicant seeks an order declaring that it has ceased to be an investment company. The applicant has transferred its assets to Aquila Tax-Free Trust of Oregon, a series of Aquila Municipal Trust, and on June 26, 2020 made a final distribution to its shareholders based on net asset value. Expenses of \$314,858 incurred in connection with the reorganization were paid by the applicant and the acquiring fund.

*Filing Date:* The application was filed on December 29, 2021.

*Applicant's Address:* [info@aquilafunds.com](mailto:info@aquilafunds.com).

**Eaton Vance Income Opportunities Fund-MA [File No. 811-23572]**

*Summary:* Applicant, a closed-end investment company, seeks an order declaring that it has ceased to be an investment company. Applicant has never made a public offering of its securities and does not propose to make a public offering or engage in business of any kind.

*Filing Dates:* The application was filed on October 29, 2021, and amended on January 12, 2022.

*Applicant's Address:* [jbeksha@eatonvance.com](mailto:jbeksha@eatonvance.com).

**NexPoint Event Driven Fund [File No. 811-23156]**

*Summary:* Applicant, a closed-end investment company, seeks an order declaring that it has ceased to be an investment company. Applicant has never made a public offering of its securities and does not propose to make a public offering or engage in business of any kind.

*Filing Date:* The application was filed on October 14, 2021.

*Applicant's Address:* [jon-luc.dupuy@klgates.com](mailto:jon-luc.dupuy@klgates.com).

**NB Crossroads Private Markets Fund VI Custody LP [File No. 811-23442]**

*Summary:* Applicant, a closed-end investment company, seeks an order declaring that it has ceased to be an investment company. Applicant has never made a public offering of its securities and does not propose to make a public offering or engage in business of any kind.

*Filing Dates:* The application was filed on November 5, 2021, and amended on January 6, 2022.

*Applicant's Address:* [corey.issing@nb.com](mailto:corey.issing@nb.com).

**Theseus U.S. Debt Fund [File No. 811-23453]**

*Summary:* Applicant, a closed-end investment company, seeks an order declaring that it has ceased to be an investment company. Applicant has never made a public offering of its securities and does not propose to make a public offering or engage in business of any kind.

*Filing Dates:* The application was filed on September 21, 2021, and amended on January 14, 2022.

*Applicant's Address:* [robert.robertson@dechert.com](mailto:robert.robertson@dechert.com).

For the Commission, by the Division of Investment Management, pursuant to delegated authority.

**J. Matthew DeLesDernier,**  
Assistant Secretary.

[FR Doc. 2022-02178 Filed 2-2-22; 8:45 am]

BILLING CODE 8011-01-P

**SECURITIES AND EXCHANGE COMMISSION**

[Release No. 34-94093; File No. SR-NYSEAMER-2022-08]

**Self-Regulatory Organizations; NYSE American LLC; Notice of Filing and Immediate Effectiveness of Proposed Change To Amend the NYSE American Options Fee Schedule**

January 28, 2022.

Pursuant to Section 19(b)(1)<sup>1</sup> of the Securities Exchange Act of 1934 (the "Act")<sup>2</sup> and Rule 19b-4 thereunder,<sup>3</sup> notice is hereby given that, on January 21, 2022, NYSE American LLC ("NYSE American" or the "Exchange") filed with the Securities and Exchange Commission (the "Commission") the proposed rule change as described in Items I, II, and III below, which Items have been prepared by the self-regulatory organization. The

<sup>1</sup> 15 U.S.C. 78s(b)(1).

<sup>2</sup> 15 U.S.C. 78a.

<sup>3</sup> 17 CFR 240.19b-4.

Commission is publishing this notice to solicit comments on the proposed rule change from interested persons.

**I. Self-Regulatory Organization's Statement of the Terms of Substance of the Proposed Rule Change**

The Exchange proposes to amend the NYSE American Options Fee Schedule ("Fee Schedule") regarding fees for Professional executions. The Exchange proposes to implement the fee change effective January 21, 2022.<sup>4</sup> The proposed change is available on the Exchange's website at [www.nyse.com](http://www.nyse.com), at the principal office of the Exchange, and at the Commission's Public Reference Room.

**II. Self-Regulatory Organization's Statement of the Purpose of, and Statutory Basis for, the Proposed Rule Change**

In its filing with the Commission, the self-regulatory organization included statements concerning the purpose of, and basis for, the proposed rule change and discussed any comments it received on the proposed rule change. The text of those statements may be examined at the places specified in Item IV below. The Exchange has prepared summaries, set forth in sections A, B, and C below, of the most significant parts of such statements.

**A. Self-Regulatory Organization's Statement of the Purpose of, and the Statutory Basis for, the Proposed Rule Change**

**1. Purpose**

The purpose of this filing is to modify certain fees for Electronic executions in the "Professional" range.<sup>5</sup> Specifically, the Exchange proposes to modify the fees for Electronic executions in the Professional range for all participants, as well as fees for Electronic executions for participants that qualify for the Professional Step-Up Incentive.<sup>6</sup> The Exchange further proposes a discounted rate for Electronic volume in the Professional range for ATP Holders that achieve Tier 3 or higher in the American

<sup>4</sup> The Exchange originally filed to amend the Fee Schedule on December 29, 2021 (SR-NYSEAmer-2021-52), with an effective date of January 3, 2022, then withdrew such filing and amended the Fee Schedule on January 12, 2022 (SR-NYSEAmer-2022-04), which latter filing the Exchange withdrew on January 21, 2022.

<sup>5</sup> For purposes of this filing, "Professional" Electronic volume includes: Professional Customer, Broker Dealer, Non-NYSE American Options Market Maker, and Firm.

<sup>6</sup> See NYSE American Options Fee Schedule, Section I.H., available at: [https://www.nyse.com/publicdocs/nyse/markets/american-options/NYSE\\_American\\_Options\\_Fee\\_Schedule.pdf](https://www.nyse.com/publicdocs/nyse/markets/american-options/NYSE_American_Options_Fee_Schedule.pdf).

## Customer Engagement (“ACE”) Program.<sup>7</sup>

The Exchange proposes to implement the rule change on January 21, 2022.

### Proposed Rule Change

#### Professional Transaction Rates

Currently, Section I.A. of the Fee Schedule (“Rates for Options transactions”) provides that the Exchange charges all participants a base rate of \$0.75 per contract for Electronic executions in the Professional range in Non-Penny issues. The Exchange proposes to increase the rate per contract for Electronic transactions in Non-Penny issues for all participants that execute in the Professional range to \$0.85 per contract.

The Exchange also proposes to increase the per contract rate for Electronic transactions in Penny issues by Firm participants from \$0.47 to \$0.49.

The Exchange further proposes to add footnote 8 in Section I.A., which would provide for an additional discount to ATP Holders that also participate in the ACE program. Specifically, ATP Holders that achieve at least ACE Tier 3 would qualify for a further discounted rate of \$0.80 per contract for Electronic transactions in the Professional range in Non-Penny issues.<sup>8</sup>

#### Professional Step-Up Incentive

The Professional Step-Up Incentive is a program offering incentives to ATP Holders that increase their Electronic volume in the Professional range. Currently, the Professional Step-Up Incentive program provides that ATP Holders that increase their monthly Electronic Professional volume by specified percentages of TCADV over their August 2019 volume or, for new ATP Holders, that increase Electronic Professional volume by specified percentages of TCADV above a base level of 10,000 contracts ADV, will qualify for certain reduced transaction rates on Electronic Professional volume, as well as credits on Electronic Customer volume at Tier 1 of the ACE

<sup>7</sup> See *id.* at Section I.E. (American Customer Engagement (“ACE”) Program). The ACE program offers tiered credits based on increasing levels of Customer Electronic Average Daily Volume (“ADV”) or Total Electronic ADV, of which 20% of the qualifying volume for the Tier must be Customer volume. Participants in the ACE Program are eligible for per contract credits on Customer volume in Electronic options transactions based on the ACE Tier achieved.

<sup>8</sup> To effect this change, the Exchange also proposes to add references to footnote 8 in the “Participant” column to specify that the rate set forth in footnote 8 would be available to Broker-Dealer, Firm, Non-NYSE American Options Market Maker, and Professional Customer participants. See proposed Fee Schedule, Section I.A.

program. The Professional Step-Up Incentive program offers such incentives at two Tiers, based on qualifying volume.

The Exchange proposes to modify the rates offered under the Professional Step-Up Incentive program to increase the per contract Non-Penny rates for both Tiers by \$0.05 per contract. Specifically, the Exchange proposes to increase the rate for Tier A from \$0.60 per contract to \$0.65 per contract, and to increase the rate for Tier B from \$0.50 per contract to \$0.55 per contract.

\* \* \* \* \*

The Exchange’s fees are constrained by intermarket competition, as ATP Holders may direct their order flow to any of the 16 options exchanges, including exchanges that charge similar fees for Professional transactions and that offer a similar incentive program for Professional volume.<sup>9</sup> Thus, ATP Holders have a choice of where they direct their order flow. The Exchange believes that the proposed modifications to the base rates applicable to Electronic executions in the Professional range (including the additional discount proposed for ATP Holders that achieve ACE Tier 3 or better) and to the Professional Step-Up Incentive program would not discourage ATP Holders from continuing to direct and execute Electronic Professional volume on the Exchange. In addition, the proposed change to provide ATP Holders that achieve ACE Tier 3 or higher with a lower per contract rate on Non-Penny Electronic transactions in the Professional range is designed to incent ATP Holders to direct such order flow to the Exchange by offering a more

<sup>9</sup> See, e.g., Nasdaq MRX, LLC (“Nasdaq MRX”) Options 7 Pricing Schedule, Section 3. Regular Order Fees and Rebates, available at: <https://listingcenter.nasdaq.com/rulebook/mrx/rules/MRX%20Options%207> (charging \$0.90 maker fee and \$1.10 taker fee for transactions by NASDAQ MRX Professional Customers in non-penny symbols); BOX Exchange (“BOX”) Fee Schedule, Section I.A. Non-Auction Transactions, available at: <https://boxoptions.com/regulatory/fee-schedule/> (providing for \$0.95 fee on BOX Professional Customer or Broker Dealer transactions with customers); Nasdaq ISE, LLC (“Nasdaq ISE”) Options 7 Pricing Schedule, Section 3. Regular Order Fees and Rebates, available at: <https://listingcenter.nasdaq.com/rulebook/ise/rules/ISE%20Options%207> (providing for \$0.70 maker fee and \$0.90 taker fee for Professional transactions); see also MIA X Options (“MIA X”) Fee Schedule, Section 1.a.iv, Professional Rebate Program, available at: [https://www.miaoptions.com/sites/default/files/fee-schedule-files/MIA\\_X\\_Options\\_Fee\\_Schedule\\_121021.pdf](https://www.miaoptions.com/sites/default/files/fee-schedule-files/MIA_X_Options_Fee_Schedule_121021.pdf) (setting forth incentive program that, like the Professional Step-Up Incentive, provides a discounted net rate on Professional (as defined by the MIA X program) electronic volume, provided the Member achieves certain Professional volume increase percentage thresholds in the month relative to the fourth quarter of 2015).

favorable rate on Professional executions while also encouraging increased Customer volume. Moreover, although the proposed changes would increase the rates for Electronic executions in the Professional range for Non-Penny issues (and, for Firm participants, the rates for executions in Penny issues), the modified rates remain lower than those charged by competing options exchanges,<sup>10</sup> and the Exchange does not believe that the modified rates would discourage ATP Holders from continuing to direct Electronic Professional volume to the Exchange, thereby promoting market quality and opportunities for order execution for all market participants. In addition, while the Exchange likewise proposes increased rates for Non-Penny contracts for participants in the Professional Step-Up Incentive program, the Exchange believes that the program, as modified, would continue to incent ATP Holders to direct both Professional and Customer order flow to the Exchange because it would continue to offer discounted rates on Professional volume coupled with ACE program Tier 1 credits on Customer volume. Thus, the Exchange believes the proposed changes should continue to incent the consistent and concerted direction of both Professional and Customer order flow to the Exchange by ATP Holders, making it a more attractive venue for trading.

## 2. Statutory Basis

The Exchange believes that the proposed rule change is consistent with Section 6(b) of the Act,<sup>11</sup> in general, and furthers the objectives of Sections 6(b)(4) and (5) of the Act,<sup>12</sup> in particular, because it provides for the equitable allocation of reasonable dues, fees, and other charges among its members, issuers and other persons using its facilities and does not unfairly discriminate between customers, issuers, brokers or dealers.

### The Proposed Rule Change Is Reasonable

The Exchange operates in a highly competitive market. The Commission has repeatedly expressed its preference for competition over regulatory intervention in determining prices, products, and services in the securities markets. In Regulation NMS, the Commission highlighted the importance of market forces in determining prices and SRO revenues and, also, recognized that current regulation of the market

<sup>10</sup> See Nasdaq MRX Pricing Schedule, BOX Fee Schedule, and Nasdaq ISE Fee Schedule, *id.*

<sup>11</sup> 15 U.S.C. 78f(b).

<sup>12</sup> 15 U.S.C. 78f(b)(4) and (5).

system “has been remarkably successful in promoting market competition in its broader forms that are most important to investors and listed companies.”<sup>13</sup>

There are currently 16 registered options exchanges competing for order flow. Based on publicly-available information, and excluding index-based options, no single exchange has more than 16% of the market share of executed volume of multiply-listed equity and ETF options trades.<sup>14</sup> Therefore, no exchange possesses significant pricing power in the execution of multiply-listed equity and ETF options order flow. More specifically, in November 2021, the Exchange had less than 8% market share of executed volume of multiply-listed equity and ETF options trades.<sup>15</sup>

The Exchange believes that the ever-shifting market share among the exchanges from month to month demonstrates that market participants can shift order flow, or discontinue or reduce use of certain categories of products, in response to fee changes. Accordingly, competitive forces constrain options exchange transaction fees. Stated otherwise, changes to exchange transaction fees can have a direct effect on the ability of an exchange to compete for order flow.

The Exchange believes that the proposed modifications to the Professional transaction fees and to the Firm charge for transactions in Penny issues are reasonable because they are within the range of fees currently charged by other options exchanges and, in the case of the Firm rate, would also more closely align with both the Exchange’s Penny rates for other executions in the Professional range and the fee charged by another options exchange.<sup>16</sup> Accordingly, the Exchange

believes that the proposed rates, although they would generally increase the rates for Professional Electronic executions, would not discourage ATP Holders from continuing to direct Professional volume to the Exchange. In addition, to the extent the proposed fees on Professional volume are coupled with new or existing incentives that are intended to encourage Customer volume (e.g., the proposed additional discount available to ATP Holders that achieve ACE Tier 3 or higher), the Exchange further believes that the proposed changes are reasonably designed to encourage ATP Holders to direct a variety of transactions to the Exchange. All market participants stand to benefit from such volume—whether Professional or Customer—as such increase promotes market depth, facilitates tighter spreads and enhances price discovery, and may lead to a corresponding increase in order flow from other market participants.

#### The Proposed Rule Change Is an Equitable Allocation of Credits and Fees

The Exchange believes the proposed rule change is an equitable allocation of its fees and credits. The proposal is based on the amount and type of business transacted on the Exchange, and ATP Holders can opt to direct their Professional Electronic order flow to the Exchange to avail themselves of the rates and incentives offered or not. The Exchange also believes that the proposed rate for Firm transactions in Penny issues would be an equitable allocation of fees because it would bring the rate closer in line with those assessed to other participants executing in the Professional range. Moreover, although the proposed changes would generally increase the rates for Electronic executions in the Professional range, the Exchange believes that they would not discourage ATP Holders from continuing to aggregate their executions at the Exchange as a primary execution venue, particularly to the extent the proposal provides opportunities for ATP Holders to qualify for reduced rates by increasing their Customer volume. The Exchange further believes that maintaining a higher fee for Professional transactions as compared to transactions by Market Makers and Specialists represents an equitable allocation of fees because Market Makers and Specialists are subject to heightened obligations and additional fees based on their roles on the Exchange.

To the extent that the proposed changes attract more Professional Electronic volume or Customer volume to the Exchange, this increased order

flow would continue to make the Exchange a more competitive venue for, among other things, order execution. Thus, the Exchange believes the proposed rule changes would improve market quality for all market participants on the Exchange and, as a consequence, attract more order flow to the Exchange thereby improving market-wide quality and price discovery.

#### The Proposed Rule Change Is Not Unfairly Discriminatory

The Exchange believes that the proposal is not unfairly discriminatory because the proposed modifications would be apply and be available to all similarly-situated market participants on an equal and non-discriminatory basis.

The proposed changes are based on the amount and type of business transacted on the Exchange and would apply to all ATP Holders that execute Professional Electronic transactions to the Exchange. The Exchange believes that the disparity between fees for Professional Electronic transactions and Electronic transactions by Market Makers or Specialists is not unfairly discriminatory because those participants are subject to heightened obligations and additional fees based on their roles on the Exchange. In addition, ATP Holders that qualify for the Professional Step-Up Incentive will still be entitled to a discounted rate based on the Tier they achieve. The Exchange also believes that increasing the rate for Firm transactions in Penny issues would not be unfairly discriminatory because it would bring the rate closer in line with those assessed for transactions by other participants in the Professional range in Penny issues. In addition, to the extent the proposed rates are intended to incent both Professional and Customer volume, the Exchange believes they are designed to continue to encourage ATP Holders to direct order flow to the Exchange and utilize the Exchange as a primary trading venue (if they have not done so previously). To the extent that the proposed changes attract more executions to the Exchange, this increased order flow would continue to make the Exchange a more competitive venue for, among other things, order execution. Thus, the Exchange believes the proposed rule changes would improve market quality for all market participants on the Exchange and, as a consequence, attract more order flow to the Exchange thereby improving market-wide quality and price discovery. The resulting increased volume and liquidity would provide more trading opportunities and tighter spreads to all market participants and

<sup>13</sup> See Securities Exchange Act Release No. 51808 (June 9, 2005), 70 FR 37496, 37499 (June 29, 2005) (S7-10-04) (“Reg NMS Adopting Release”).

<sup>14</sup> The OCC publishes options and futures volume in a variety of formats, including daily and monthly volume by exchange, available at: <https://www.theocc.com/Market-Data/Market-Data-Reports/Volume-and-Open-Interest/Monthly-Weekly-Volume-Statistics>.

<sup>15</sup> Based on a compilation of OCC data for monthly volume of equity-based options and monthly volume of ETF-based options, see *id.*, the Exchange’s market share in equity-based options was 9.09% for the month of November 2020 and 7.06% for the month of November 2021.

<sup>16</sup> See Nasdaq MRX Pricing Schedule, BOX Fee Schedule, and Nasdaq ISE Fee Schedule, *supra* note 9; see also Fee Schedule, Section I.A. (providing for \$0.50 per contract rate for Penny issues for Broker-Dealer, Non-NYSE American Options Market Maker, and Professional Customer participants); Nasdaq Options Market, Options 7 Pricing Schedule, Section 2 Nasdaq Options Market—Fees and Rebates, available at: <https://listingcenter.nasdaq.com/rulebook/nasdaq/rules/Nasdaq%20Options%207> (setting forth \$0.50 fee for Firms to remove liquidity in penny symbols).

thus would promote just and equitable principles of trade, remove impediments to and perfect the mechanism of a free and open market and a national market system and, in general, protect investors and the public interest.

Finally, the Exchange believes that it is subject to significant competitive forces, as described below in the Exchange's statement regarding the burden on competition.

For the foregoing reasons, the Exchange believes that the proposal is consistent with the Act.

#### *B. Self-Regulatory Organization's Statement on Burden on Competition*

In accordance with Section 6(b)(8) of the Act, the Exchange does not believe that the proposed rule change would impose any burden on competition that is not necessary or appropriate in furtherance of the purposes of the Act. Instead, as discussed above, the Exchange believes that the proposed changes would encourage the submission of additional liquidity to a public exchange, thereby promoting market depth, price discovery and transparency and enhancing order execution opportunities for all market participants. As a result, the Exchange believes that the proposed change furthers the Commission's goal in adopting Regulation NMS of fostering integrated competition among orders, which promotes "more efficient pricing of individual stocks for all types of orders, large and small."<sup>17</sup>

*Intramarket Competition.* The Exchange believes that the proposed modifications to the base rates for Professional Electronic transactions, as well as to the rates available to ATP Holders that qualify for the Professional Step-Up Incentive, would continue to incent market participants to direct both Professional and Customer volume to the Exchange. Greater liquidity benefits all market participants on the Exchange, and increased Electronic Professional volume would increase opportunities for execution of other trading interest. In addition, the base rates, as modified, would be the same for all participants executing Professional Electronic volume in Non-Penny issues, and the rates for ATP Holders that achieve the Professional Step-Up Incentive will continue to be discounted and maintain the incentive structure of the two Tiers of that program. In addition, while Professional transactions will continue to be subject to a higher fee than transactions by Market Makers or

Specialists, the Exchange does not believe that the proposed change would impose any burden on competition that is not necessary or appropriate because the lower fees offered to Market Makers or Specialists on their Electronic transactions are balanced with heightened obligations and additional fees based on their roles on the Exchange.

*Intermarket Competition.* The Exchange operates in a highly competitive market in which market participants can readily favor one of the 16 competing option exchanges if they deem fee levels at a particular venue to be excessive. In such an environment, the Exchange must continually adjust its fees to remain competitive with other exchanges (including other options exchanges with a similar incentive program or comparable transaction fees)<sup>18</sup> and to attract order flow to the Exchange. Based on publicly-available information, and excluding index-based options, no single exchange has more than 16% of the market share of executed volume of multiply-listed equity and ETF options trades.<sup>19</sup> Therefore, no exchange possesses significant pricing power in the execution of multiply-listed equity & ETF options order flow. More specifically, in November 2021, the Exchange had less than 8% market share of executed volume of multiply-listed equity and ETF options trades.<sup>20</sup>

The Exchange believes that the proposed rule change reflects this competitive environment because it modifies the Exchange's fees in a manner designed to continue to encourage ATP Holders to direct trading interest to the Exchange, to provide liquidity and to attract order flow, including by continuing to provide discounted rates for ATP Holders that achieve the Professional Step-Up Incentive and offering a new discounted rate to ATP Holders that execute the requisite Customer volume to achieve ACE Tier 3. To the extent that this purpose is achieved, all the Exchange's market participants should benefit from the improved market quality and increased opportunities for price improvement.

Thus, the Exchange believes that the proposed change could promote competition between the Exchange and other execution venues, including those that currently offer similar pricing models, by encouraging additional orders to be sent to the Exchange for execution.

#### *C. Self-Regulatory Organization's Statement on Comments on the Proposed Rule Change Received From Members, Participants, or Others*

No written comments were solicited or received with respect to the proposed rule change.

#### **III. Date of Effectiveness of the Proposed Rule Change and Timing for Commission Action**

The foregoing rule change is effective upon filing pursuant to Section 19(b)(3)(A)<sup>21</sup> of the Act and subparagraph (f)(2) of Rule 19b-4<sup>22</sup> thereunder, because it establishes a due, fee, or other charge imposed by the Exchange.

At any time within 60 days of the filing of such proposed rule change, the Commission summarily may temporarily suspend such rule change if it appears to the Commission that such action is necessary or appropriate in the public interest, for the protection of investors, or otherwise in furtherance of the purposes of the Act. If the Commission takes such action, the Commission shall institute proceedings under Section 19(b)(2)(B)<sup>23</sup> of the Act to determine whether the proposed rule change should be approved or disapproved.

#### **IV. Solicitation of Comments**

Interested persons are invited to submit written data, views, and arguments concerning the foregoing, including whether the proposed rule change is consistent with the Act. Comments may be submitted by any of the following methods:

##### *Electronic Comments*

- Use the Commission's internet comment form (<http://www.sec.gov/rules/sro.shtml>); or
- Send an email to [rule-comments@sec.gov](mailto:rule-comments@sec.gov). Please include File Number SR-NYSEAMER-2022-08 on the subject line.

##### *Paper Comments*

- Send paper comments in triplicate to Secretary, Securities and Exchange Commission, 100 F Street NE, Washington, DC 20549-1090.

All submissions should refer to File Number SR-NYSEAMER-2022-08. This file number should be included on the subject line if email is used. To help the Commission process and review your comments more efficiently, please use only one method. The Commission will post all comments on the Commission's

<sup>18</sup> See *supra* note 9.

<sup>19</sup> See *supra* note 14.

<sup>20</sup> See *supra* note 15.

<sup>21</sup> 15 U.S.C. 78s(b)(3)(A).

<sup>22</sup> 17 CFR 240.19b-4(f)(2).

<sup>23</sup> 15 U.S.C. 78s(b)(2)(B).

<sup>17</sup> See Reg NMS Adopting Release, *supra* note 13, at 37499.

internet website (<http://www.sec.gov/rules/sro.shtml>). Copies of the submission, all subsequent amendments, all written statements with respect to the proposed rule change that are filed with the Commission, and all written communications relating to the proposed rule change between the Commission and any person, other than those that may be withheld from the public in accordance with the provisions of 5 U.S.C. 552, will be available for website viewing and printing in the Commission's Public Reference Room, 100 F Street NE, Washington, DC 20549 on official business days between the hours of 10:00 a.m. and 3:00 p.m. Copies of the filing also will be available for inspection and copying at the principal office of the Exchange. All comments received will be posted without change. Persons submitting comments are cautioned that we do not redact or edit personal identifying information from comment submissions. You should submit only information that you wish to make available publicly. All submissions should refer to File Number SR-NYSEAMER-2022-08, and should be submitted on or before February 24, 2022.

For the Commission, by the Division of Trading and Markets, pursuant to delegated authority.<sup>24</sup>

**J. Matthew DeLesDernier,**

*Assistant Secretary.*

[FR Doc. 2022-02181 Filed 2-2-22; 8:45 am]

BILLING CODE 8011-01-P

## SECURITIES AND EXCHANGE COMMISSION

[Release No. 34-94095; No. SR-NYSEArca-2022-04]

### Self-Regulatory Organizations; NYSE Arca, Inc.; Notice of Filing and Immediate Effectiveness of Proposed Rule Change To Amend the NYSE Arca Options Fee Schedule

January 28, 2022.

Pursuant to Section 19(b)(1)<sup>1</sup> of the Securities Exchange Act of 1934 (the "Act")<sup>2</sup> and Rule 19b-4 thereunder,<sup>3</sup> notice is hereby given that, on January 25, 2022, NYSE Arca, Inc. ("NYSE Arca" or the "Exchange") filed with the Securities and Exchange Commission (the "Commission") the proposed rule change as described in Items I, II, and III below, which Items have been

prepared by the self-regulatory organization. The Commission is publishing this notice to solicit comments on the proposed rule change from interested persons.

#### I. Self-Regulatory Organization's Statement of the Terms of Substance of the Proposed Rule Change

The Exchange proposes to amend the NYSE Arca Options Fee Schedule (the "Fee Schedule") to provide for a waiver of the Ratio Threshold Fee in connection with the Exchange's migration to a new trading platform. The proposed rule change is available on the Exchange's website at [www.nyse.com](http://www.nyse.com), at the principal office of the Exchange, and at the Commission's Public Reference Room.

#### II. Self-Regulatory Organization's Statement of the Purpose of, and Statutory Basis for, the Proposed Rule Change

In its filing with the Commission, the self-regulatory organization included statements concerning the purpose of, and basis for, the proposed rule change and discussed any comments it received on the proposed rule change. The text of those statements may be examined at the places specified in Item IV below. The Exchange has prepared summaries, set forth in sections A, B, and C below, of the most significant parts of such statements.

##### A. Self-Regulatory Organization's Statement of the Purpose of, and the Statutory Basis for, the Proposed Rule Change

###### 1. Purpose

The purpose of this filing is to amend the Fee Schedule to waive the Ratio Threshold Fee during the Exchange's migration of options trading to a new electronic trading platform.

Currently, the Exchange conducts options trading on an electronic platform known as "OX." OX refers to the Exchange's electronic order delivery, execution, and reporting system for designated option issues through which orders and quotes of Users are consolidated for execution and/or display.<sup>4</sup> On or about February 7, 2022, the Exchange anticipates beginning the migration of its options trading to a new technology platform known as Pillar.<sup>5</sup>

<sup>4</sup> See NYSE Arca Rule 6.1A-O(a)(13).

<sup>5</sup> The Exchange has announced that, pending regulatory approval, it will begin migrating Exchange-listed options to Pillar on February 7, 2022, available here: <https://www.nyse.com/trader-update/history#110000322291>. See also Securities Exchange Act Release No. 92304 (June 30, 2021), 86 FR 36440 (July 9, 2021) (SR-NYSEArca-2021-47)

The Ratio Threshold Fee is based on the number of orders entered as compared to the number of executions received in a calendar month and is intended to deter OTP Holders and OTP Firms (collectively, "OTP Holders") from submitting an excessive number of orders that are not executed.<sup>6</sup> Because order to execution ratios of 10,000 to 1 or greater have the potential residual effect of exhausting system resources, bandwidth, and capacity, such ratios may create latency and impact other OTP Holders' ability to receive timely executions.<sup>7</sup>

The Exchange proposes to modify the Fee Schedule to specify that the monthly Ratio Threshold Fee assessed to OTP Holders will be waived for the duration of the migration and for three calendar months after the migration. Specifically, the Exchange proposes that the waiver of the Ratio Threshold Fee take effect for the month during which the migration begins and remain in effect for three months following the month in which the migration is completed (the "Waiver Period"). The Exchange believes that waiving Ratio Threshold Fees during the Waiver Period will give both OTP Holders and the Exchange an opportunity to adjust to new functionality and new order handling mechanisms without imposing a financial burden on OTP Holders based on their order to execution ratios during the Pillar transition. In addition, during the Waiver Period, the Exchange intends to work closely with OTP Holders to monitor traffic rates and their order to execution ratio as they adapt to trading on the Pillar platform.

The Exchange proposes to implement this change beginning in the month during which it commences its migration to the Pillar platform.

###### 2. Statutory Basis

The Exchange believes that the proposed rule change is consistent with Section 6(b) of the Act,<sup>8</sup> in general, and furthers the objectives of Sections 6(b)(4) and (5) of the Act,<sup>9</sup> in particular,

(SR-NYSEArca-2021-47) (Notice of Filing of Proposed Rule Change for New Rules 6.1P-O, 6.37AP-O, 6.40P-O, 6.41P-O, 6.62P-O, 6.64P-O, 6.76P-O, and 6.76AP-O and Amendments to Rules 1.1, 6.1-O, 6.1A-O, 6.37-O, 6.65A-O and 6.96-O) and Amendment No. 4 to SR-NYSEArca-2021-47, available here: <https://www.sec.gov/comments/sr-nysearca-2021-47/srnysearca202147-20112491-265389.pdf>.

<sup>6</sup> See Fee Schedule, RATIO THRESHOLD FEE, available here: [https://www.nyse.com/publicdocs/nyse/markets/arca-options/NYSE\\_Arca\\_Options\\_Fee\\_Schedule.pdf](https://www.nyse.com/publicdocs/nyse/markets/arca-options/NYSE_Arca_Options_Fee_Schedule.pdf); see also Securities Exchange Act Release No. 60102 (June 11, 2009), 74 FR 29251 (June 19, 2009) (SR-NYSEArca-2009-50).

<sup>7</sup> See *id.*

<sup>8</sup> 15 U.S.C. 78f(b).

<sup>9</sup> 15 U.S.C. 78f(b)(4) and (5).

<sup>24</sup> 17 CFR 200.30-3(a)(12).

<sup>1</sup> 15 U.S.C. 78s(b)(1).

<sup>2</sup> 15 U.S.C. 78a.

<sup>3</sup> 17 CFR 240.19b-4.

because it provides for the equitable allocation of reasonable dues, fees, and other charges among its members, issuers and other persons using its facilities and does not unfairly discriminate between customers, issuers, brokers or dealers.

#### The Proposed Rule Change Is Reasonable

The Exchange operates in a highly competitive market. The Commission has repeatedly expressed its preference for competition over regulatory intervention in determining prices, products, and services in the securities markets. In Regulation NMS, the Commission highlighted the importance of market forces in determining prices and SRO revenues and, also, recognized that current regulation of the market system “has been remarkably successful in promoting market competition in its broader forms that are most important to investors and listed companies.”<sup>10</sup>

There are currently 16 registered options exchanges competing for order flow. Based on publicly-available information, and excluding index-based options, no single exchange has more than 16% of the market share of executed volume of multiply-listed equity and ETF options trades.<sup>11</sup> Therefore, currently no exchange possesses significant pricing power in the execution of multiply-listed equity & ETF options order flow. More specifically, in December 2021, the Exchange had less than 14% market share of executed volume of multiply-listed equity & ETF options trades.<sup>12</sup>

The Exchange believes that the ever-shifting market share among the exchanges from month to month demonstrates that market participants can shift order flow or discontinue or reduce use of certain categories of products, in response to fee changes. Accordingly, competitive forces constrain options exchange fees. In response to this competitive environment and to adapt to extenuating circumstances, the

<sup>10</sup> See Securities Exchange Act Release No. 51808 (June 9, 2005), 70 FR 37496, 37499 (June 29, 2005) (S7-10-04) (“Reg NMS Adopting Release”).

<sup>11</sup> The OCC publishes options and futures volume in a variety of formats, including daily and monthly volume by exchange, available here: <https://www.theocc.com/Market-Data/Market-Data-Reports/Volume-and-Open-Interest/Monthly-Weekly-Volume-Statistics>.

<sup>12</sup> Based on a compilation of OCC data for monthly volume of equity-based options and monthly volume of ETF-based options, see *id.*, the Exchange’s market share in equity-based options increased from 9.65% for the month of December 2020 to 13.21% for the month of December 2021.

Exchange has previously waived fees on a temporary basis.<sup>13</sup>

The Exchange believes that the proposed waiver of Ratio Threshold Fees is reasonably designed to continue to incent OTP Holders to maintain active participation on the Exchange during and after its migration to a new trading platform. The Exchange further believes that the proposed waiver is reasonably designed to lessen the impact of the migration on OTP Holders and would thus encourage OTP Holders to promptly transition to the more efficient Pillar technology platform, while enabling them to adjust their trading activity on the Exchange as needed to transition to Pillar without incurring excess Ratio Threshold Fees during the Waiver Period.

To the extent the proposed rule change encourages OTP Holders to migrate to the new platform while maintaining their level of trading activity, the Exchange believes the proposed change would sustain the Exchange’s overall competitiveness and its market quality for all market participants. In the backdrop of the competitive environment in which the Exchange operates, the proposed rule change is a reasonable attempt by the Exchange to mitigate the expense of the migration without affecting its competitiveness.

#### The Proposed Rule Change is an Equitable Allocation of Credits and Fees

The Exchange believes the proposed rule change is an equitable allocation of its fees and credits because the waiver would be offered to all OTP Holders. All OTP Holders would thus have the opportunity to moderate their order flow as needed and familiarize themselves with the new system during the Waiver Period without incurring Ratio Threshold Fees. Thus, the Exchange believes the proposed rule change would facilitate a smooth transition to the Pillar technology platform for OTP Holders and mitigate the impact of the migration process for all market participants on the Exchange, thereby sustaining market-wide quality.

#### The Proposed Rule Change Is Not Unfairly Discriminatory

The Exchange believes the proposed waiver of Ratio Threshold Fees is not unfairly discriminatory because it would be available to all similarly-situated market participants on an equal and non-discriminatory basis.

<sup>13</sup> See, e.g., Securities Exchange Act Release No. 88596 (April 8, 2020), 85 FR 20796 (April 14, 2020) (SR-NYSEArca-2020-29) (waiving Floor related fees in connection with COVID-19 precautionary measures).

The proposed waiver would permit all OTP Holders to maintain the same level of interaction or adjust their proprietary systems and order submission to the Exchange as needed during the Waiver Period without incurring additional fees based on their monthly order to execution ratios, which could fluctuate as they adapt to the Pillar platform. The Exchange thus believes that the proposed change would support continued trading opportunities for all market participants, thereby promoting just and equitable principles of trade, removing impediments to and perfecting the mechanism of a free and open market and a national market system and, in general, protecting investors and the public interest.

Finally, the Exchange believes that it is subject to significant competitive forces, as described below in the Exchange’s statement regarding the burden on competition.

#### B. Self-Regulatory Organization’s Statement on Burden on Competition

In accordance with Section 6(b)(8) of the Act, the Exchange does not believe that the proposed rule change would impose any burden on competition that is not necessary or appropriate in furtherance of the purposes of the Act. Instead, as discussed above, the Exchange believes that the proposed changes would encourage the submission of additional liquidity to a public exchange, thereby promoting market depth, price discovery and transparency and enhancing order execution opportunities for all market participants. As a result, the Exchange believes that the proposed change furthers the Commission’s goal in adopting Regulation NMS of fostering integrated competition among orders, which promotes “more efficient pricing of individual stocks for all types of orders, large and small.”<sup>14</sup>

*Intramarket Competition.* The Exchange does not believe the proposed rule change would impose any burden on intramarket competition that is not necessary or appropriate because it would apply equally to all OTP Holders. All OTP Holders would be eligible for the waiver of their Ratio Threshold Fees beginning in the month during which the Exchange begins the Pillar migration, and the waiver would remain in effect for three full months after the month during which the migration to Pillar is completed.

*Intermarket Competition.* The Exchange operates in a highly

<sup>14</sup> See Reg NMS Adopting Release, *supra* note 10, at 37499.



competitive market in which market participants can readily favor one of the 16 competing option exchanges if they deem fee levels at a particular venue to be excessive. In such an environment, the Exchange must continually adjust its fees to remain competitive with other exchanges and to attract order flow to the Exchange. Based on publicly-available information, and excluding index-based options, no single exchange has more than 16% of the market share of executed volume of multiply-listed equity and ETF options trades.<sup>15</sup> Therefore, currently no exchange possesses significant pricing power in the execution of multiply-listed equity & ETF options order flow. More specifically, in December 2021, the Exchange had less than 14% market share of executed volume of multiply-listed equity & ETF options trades.<sup>16</sup>

The Exchange does not believe the proposed rule change would impose any burden on intermarket competition that is not necessary or appropriate because the Exchange operates in a highly competitive market in which market participants can readily choose to send their orders to other exchanges if they deem fee levels at those other venues to be more favorable. The Exchange believes that fees to prevent excessive use of Exchange systems are constrained by the robust competition for order flow among exchanges. Accordingly, the Exchange believes that the proposed change would continue to make the Exchange a competitive venue for order execution by enabling OTP Holders to maintain their current levels of interaction with the Exchange or make adjustments as needed during the transition to Pillar platform, without incurring fees based on their monthly order to execution ratios during the Waiver Period, thus facilitating OTP Holders' migration to the newer, more efficient Pillar technology platform.

#### C. Self-Regulatory Organization's Statement on Comments on the Proposed Rule Change Received From Members, Participants, or Others

No written comments were solicited or received with respect to the proposed rule change.

<sup>15</sup> See *supra* note 11.

<sup>16</sup> Based on a compilation of OCC data for monthly volume of equity-based options and monthly volume of ETF-based options, *see id.*, the Exchange's market share in equity-based options increased from 9.65% for the month of December 2020 to 13.21% for the month of December 2021.

### III. Date of Effectiveness of the Proposed Rule Change and Timing for Commission Action

The foregoing rule change is effective upon filing pursuant to Section 19(b)(3)(A)<sup>17</sup> of the Act and subparagraph (f)(2) of Rule 19b-4<sup>18</sup> thereunder, because it establishes a due, fee, or other charge imposed by the Exchange.

At any time within 60 days of the filing of such proposed rule change, the Commission summarily may temporarily suspend such rule change if it appears to the Commission that such action is necessary or appropriate in the public interest, for the protection of investors, or otherwise in furtherance of the purposes of the Act. If the Commission takes such action, the Commission shall institute proceedings under Section 19(b)(2)(B)<sup>19</sup> of the Act to determine whether the proposed rule change should be approved or disapproved.

### IV. Solicitation of Comments

Interested persons are invited to submit written data, views, and arguments concerning the foregoing, including whether the proposed rule change is consistent with the Act. Comments may be submitted by any of the following methods:

#### Electronic Comments

- Use the Commission's internet comment form (<http://www.sec.gov/rules/sro.shtml>); or
- Send an email to [rule-comments@sec.gov](mailto:rule-comments@sec.gov). Please include File Number SR-NYSEArca-2022-04 on the subject line.

#### Paper Comments

- Send paper comments in triplicate to Secretary, Securities and Exchange Commission, 100 F Street NE, Washington, DC 20549-1090.

All submissions should refer to File Number SR-NYSEArca-2022-04. This file number should be included on the subject line if email is used. To help the Commission process and review your comments more efficiently, please use only one method. The Commission will post all comments on the Commission's internet website (<http://www.sec.gov/rules/sro.shtml>). Copies of the submission, all subsequent amendments, all written statements with respect to the proposed rule change that are filed with the Commission, and all written communications relating to the proposed rule change between the

<sup>17</sup> 15 U.S.C. 78s(b)(3)(A).

<sup>18</sup> 17 CFR 240.19b-4(f)(2).

<sup>19</sup> 15 U.S.C. 78s(b)(2)(B).

Commission and any person, other than those that may be withheld from the public in accordance with the provisions of 5 U.S.C. 552, will be available for website viewing and printing in the Commission's Public Reference Room, 100 F Street NE, Washington, DC 20549 on official business days between the hours of 10:00 a.m. and 3:00 p.m. Copies of the filing also will be available for inspection and copying at the principal office of the Exchange. All comments received will be posted without change. Persons submitting comments are cautioned that we do not redact or edit personal identifying information from comment submissions. You should submit only information that you wish to make available publicly. All submissions should refer to File Number SR-NYSEArca-2022-04, and should be submitted on or before February 24, 2022.

For the Commission, by the Division of Trading and Markets, pursuant to delegated authority.<sup>20</sup>

**J. Matthew DeLesDernier,**

*Assistant Secretary.*

[FR Doc. 2022-02184 Filed 2-2-22; 8:45 am]

BILLING CODE 8011-01-P

## SECURITIES AND EXCHANGE COMMISSION

[Release No. 34-94097; File No. SR-NASDAQ-2022-011]

### Self-Regulatory Organizations; The Nasdaq Stock Market LLC; Notice of Filing and Immediate Effectiveness of Proposed Rule Change To Amend Equity 7, Section 114 and Section 118 of the Fee Schedule

January 28, 2022.

Pursuant to Section 19(b)(1) of the Securities Exchange Act of 1934 ("Act"),<sup>1</sup> and Rule 19b-4 thereunder,<sup>2</sup> notice is hereby given that on January 27, 2022, The Nasdaq Stock Market LLC ("Nasdaq" or "Exchange") filed with the Securities and Exchange Commission ("SEC" or "Commission") the proposed rule change as described in Items I, II, and III, below, which Items have been prepared by the Exchange. The Commission is publishing this notice to solicit comments on the proposed rule change from interested persons.

<sup>20</sup> 17 CFR 200.30-3(a)(12).

<sup>1</sup> 15 U.S.C. 78s(b)(1).

<sup>2</sup> 17 CFR 240.19b-4.

## I. Self-Regulatory Organization's Statement of the Terms of Substance of the Proposed Rule Change

The Exchange proposes to amend the Exchange's pricing schedule at Equity 7, Section 114 and Section 118, as described further below.

The text of the proposed rule change is available on the Exchange's website at <https://listingcenter.nasdaq.com/rulebook/nasdaq/rules>, at the principal office of the Exchange, and at the Commission's Public Reference Room.

## II. Self-Regulatory Organization's Statement of the Purpose of, and Statutory Basis for, the Proposed Rule Change

In its filing with the Commission, the Exchange included statements concerning the purpose of and basis for the proposed rule change and discussed any comments it received on the proposed rule change. The text of these statements may be examined at the places specified in Item IV below. The Exchange has prepared summaries, set forth in sections A, B, and C below, of the most significant aspects of such statements.

### A. Self-Regulatory Organization's Statement of the Purpose of, and Statutory Basis for, the Proposed Rule Change

#### 1. Purpose

The purpose of the proposed rule change is to amend the Exchange's schedule of credits, at Equity 7, Section 114 and Section 118(a). Specifically, the Exchange proposes to (1) amend the Exchange's Tier 1 rebate to Qualified Market Maker ("QMM") at Equity 7, Section 114(e); (2) amend a supplemental credit in Tapes A, B and C for displayed quotes/orders (other than Supplemental Orders or Designated Retail Orders); (3) amend certain supplemental credits for displayed quotes/orders (other than Supplemental Orders) in Tapes A, B and C and (4) allow members to receive the higher rebate when the member's non-Designated Retail Order rebate is greater than its Designated Retail Order rebate.

#### Changes to Section 114

The Exchange proposes to amend its pricing schedule, at Equity 7, Section 114(e), to make a change to its Qualified Market Maker ("QMM") Program. The QMM Program provides supplemental incentives to member organizations that meet certain quality standards in acting as market makers for securities on the Exchange.

Specifically, the Exchange proposes to adjust the threshold to also allow a

QMM to qualify for the Tier 1 incentive if the QMM executes shares of liquidity provided in all securities through one or more of its Nasdaq Market Center MPIDs that represent 70 million shares of average daily volume during the month (inclusive of volume and Consolidated Volume<sup>3</sup> that consists of securities priced less than \$1). Therefore, the amended Tier 1 incentive would provide a \$0.0001 supplemental credit if a QMM executes shares of liquidity provided in all securities through one or more of its Nasdaq Market Center MPIDs that represent above 0.70% up to, and including, 0.90% of Consolidated Volume or 70 million shares of average daily volume during the month (inclusive of volume and Consolidated Volume that consists of securities priced less than \$1). The Exchange intends for the additional threshold to provide greater incentives to members during times when the market is trading at a higher than usual daily volume.<sup>4</sup>

#### Changes to Section 118

The Exchange currently provides a \$0.0001 per share supplemental credit to members for displayed quotes/orders that provide liquidity (other than Supplemental Orders or Designated Retail Orders) where the members, through one or more of its Nasdaq Market Center MPIDs, (i) increases its shares of liquidity provided in all securities by at least 30% as a percentage of Consolidated Volume<sup>5</sup>

<sup>3</sup> Pursuant to Equity 7, Section 114(h), the term "Consolidated Volume" shares the meaning of that term set forth in Equity 7, Section 118(a). (For purposes of calculating a member's qualifications for Tiers 1 and 2 of the QMM Program credits set forth in paragraph (e) of this Section, the Exchange will calculate a member's volume and total Consolidated Volume twice. First, the Exchange will calculate a member's volume and total Consolidated Volume inclusive of volume that consists of executions in securities priced less than \$1. Second, the Exchange will calculate a member's volume and total Consolidated Volume exclusive of volume that consists of executions in securities priced less than \$1, while also applying distinct qualifying volume thresholds to each Tier, as set forth above in paragraph (e). The Exchange will then assess which of these two calculations would qualify the member for the most advantageous credits for the month and then it will apply those credits to the member.)

<sup>4</sup> The proposal provides a third alternative for members to qualify for the Tier 1 rebate.

<sup>5</sup> Pursuant to Equity 7, Section 118(a), the term "Consolidated Volume" shall mean the total consolidated volume reported to all consolidated transaction reporting plans by all exchanges and trade reporting facilities during a month in equity securities, excluding executed orders with a size of less than one round lot. For purposes of calculating Consolidated Volume and the extent of a member's trading activity the date of the annual reconstitution of the Russell Investments Indexes shall be excluded from both total Consolidated Volume and the member's trading activity. For the purposes of calculating the extent of a member's trading activity during the month on Nasdaq and determining the

during the month relative to the month of October 2021 and (ii) has shares of liquidity provided of least 15 million ADV during the month. The Exchange now proposes to amend the threshold to allow a member to qualify if the member increases its shares of liquidity provided in all securities by at least 30% relative to the month of October 2021 or November 2021. The Exchange hopes that it will incentivize members to increase their liquidity providing activity on the Exchange by giving members the option of an additional month of Consolidated Volume to measure their liquidity against, which the Exchange hopes will improve market quality.

Additionally, the Exchange proposes to amend in two respects, its schedule of credits, which it provides to members for displayed quotes/orders that provide liquidity. First, the Exchange is proposing to remove the \$0.0001 per share executed and the \$0.00015 per share executed supplemental credits in Tapes A, B and C that are provided to members for displayed quotes/orders (other than Supplemental Orders) that provide liquidity. Second, the Exchange is proposing to add these two supplemental credits to the current credits in Tapes A, B and C that are provided to members for displayed quotes/orders (other than Supplemental Orders or Designated Retail Orders) that provide liquidity.

Specifically, one of the two supplemental credits is a \$0.0001 per share executed credit provided when a member, through one or more of its Nasdaq Market Center MPIDs, either: (i) Increases the extent of its ADV of MELO Orders and/or midpoint orders (that execute against MELO Orders) in all securities by an ADV of 1 million shares or more during the month relative to the month of June 2021; or (ii) executes a combined volume of at least 3 million shares ADV through midpoint orders provided and MELO Orders during the month and increases the extent of its ADV of midpoint orders provided and MELO Orders in all securities by 100% or more during the month relative to the month of June 2021. The other supplemental credit is a \$0.00015 per share executed credit provided when a member, through one or more of its Nasdaq Market Center MPIDs, either: (i) Increases the extent of its ADV of MELO Orders and/or midpoint orders (that execute against MELO Orders) in all securities by an ADV of 2 million shares

charges and credits applicable to such member's activity, all M-EO Orders that a member executes on Nasdaq during the month will count as liquidity-adding activity on Nasdaq.

or more during the month relative to the month of June 2021; or (ii) executes a combined volume of at least 4 million shares ADV through midpoint orders provided and MELO Orders during the month and increases the extent of its ADV of midpoint orders provided and MELO Orders in all securities by 150% or more during the month relative to the month of June 2021. These two credits may not be combined with each other.

Although the Exchange did not exclude retail orders when it proposed these two supplemental credits in Tapes A, B and C,<sup>6</sup> the Exchange did not intend to include Designated Retail Orders in the payment of these supplemental credits. Currently, Designated Retail Orders receive their own separate credits on the Exchange's fee schedule and those orders generally receive higher rebates. The Exchange does not commonly provide additional rebates to Designated Retail Orders and therefore, is proposing to update its fee schedule to accurately reflect the manner in which it will pay these supplemental credits going forward.<sup>7</sup>

Lastly, the Exchange is proposing to allow a member to receive the higher rebate for its Designated Retail Orders if the member's total rebate for non-Designated Retail Orders (including any supplemental credits provided in Section 114 and Section 118, except the NBBO Program credit provided in Section 114(g)) is greater than its rebate for Designated Retail Orders (including supplemental credits provided in Section 114 and Section 118). For example, a member that provides liquidity for Designated Retail Orders could qualify for a credit of \$0.00325 per share executed. However, if the member provides liquidity for displayed quotes/orders (other than Supplemental Orders or Designated Retail Orders), the member could qualify for a credit of \$0.00305 per share executed and could also qualify for an additional \$0.0002 per share executed through the QMM Program, as well as an additional supplemental credit of \$0.0001 per share executed, making the member's total possible credit for displayed non-Designated Retail Orders \$0.00335 per share. In this case, the member would also receive a credit of \$0.00335 per share for its Designated Retail Orders.

<sup>6</sup> Securities Exchange Act Release No. 92433 (July 6, 2021), 86 FR 38772 (July 22, 2021).

<sup>7</sup> Since the \$0.0001 per share executed and the \$0.00015 per share executed credits were established in July 2021, the Exchange has not been applying the credit to Designated Retail Orders when calculating a firm's credits. Therefore, the Exchange is working to retroactively provide credits to firms that would have received credits if their Designated Retail Orders were not excluded. Under the proposal, there will be three ways for firm [sic].

The Exchange is excluding the NBBO Program when calculating a member's highest rebate because the NBBO Program only applies to displayed orders in securities priced at \$1 or more per share that provide liquidity, establish the national best bid or best offer ("NBBO"), and display a quantity of at least one round lot at the time of execution. Consistent with the proposed rule, the NBBO Program explicitly excludes Designated Retail Orders.

The Exchange is proposing this change to ensure that none of its members are disadvantaged and that all members can obtain the maximum possible rebate.

The Exchange notes that those participants that are dissatisfied with this new proposal are free to shift their order flow to competing venues.

## 2. Statutory Basis

The Exchange believes that its proposal is consistent with Section 6(b) of the Act,<sup>8</sup> in general, and furthers the objectives of Sections 6(b)(4) and 6(b)(5) of the Act,<sup>9</sup> in particular, in that it provides for the equitable allocation of reasonable dues, fees and other charges among members and issuers and other persons using any facility, and is not designed to permit unfair discrimination between customers, issuers, brokers, or dealers. The proposal is also consistent with Section 11A of the Act relating to the establishment of the national market system for securities.

### The Proposal is Reasonable

The Exchange's proposal is reasonable in several respects. As a threshold matter, the Exchange is subject to significant competitive forces in the market for equity securities transaction services that constrain its pricing determinations in that market. The fact that this market is competitive has long been recognized by the courts. In *NetCoalition v. Securities and Exchange Commission*, the D.C. Circuit stated as follows: "[n]o one disputes that competition for order flow is 'fierce.' . . . As the SEC explained, '[i]n the U.S. national market system, buyers and sellers of securities, and the broker-dealers that act as their order-routing agents, have a wide range of choices of where to route orders for execution'; [and] 'no exchange can afford to take its market share percentages for granted' because 'no exchange possesses a monopoly, regulatory or otherwise, in

<sup>8</sup> 15 U.S.C. 78f(b).

<sup>9</sup> 15 U.S.C. 78f(b)(4) and (5).

the execution of order flow from broker dealers'. . . ." <sup>10</sup>

The Commission and the courts have repeatedly expressed their preference for competition over regulatory intervention in determining prices, products, and services in the securities markets. In Regulation NMS, while adopting a series of steps to improve the current market model, the Commission highlighted the importance of market forces in determining prices and SRO revenues and, also, recognized that current regulation of the market system "has been remarkably successful in promoting market competition in its broader forms that are most important to investors and listed companies."<sup>11</sup>

Numerous indicia demonstrate the competitive nature of this market. For example, clear substitutes to the Exchange exist in the market for equity security transaction services. The Exchange is only one of several equity venues to which market participants may direct their order flow. Competing equity exchanges offer similar tiered pricing structures to that of the Exchange, including schedules of rebates and fees that apply based upon members achieving certain volume thresholds.

The Exchange believes it is reasonable to amend the Tier 1 threshold of its QMM Program to provide the option for a QMM to qualify if the QMM executes shares of liquidity provided that represent 70 million shares of average daily volume during the month (inclusive of volume that consists of securities priced less than \$1). The Exchange also believes that the additional threshold option of 70 million shares of average daily volume will provide an increased incentive to members during times when the market is trading at a higher than usual daily volume. An increase in liquidity adding activity on the Exchange will, in turn, improve the quality of the Nasdaq market and increase its attractiveness to existing and prospective participants.

The Exchange notes that those participants that are dissatisfied with the new threshold option are free to shift their order flow to competing venues.

Additionally, the Exchange believes that it is reasonable to include the option of an additional baseline month to measure whether a member increases its shares of liquidity provided in all

<sup>10</sup> *NetCoalition v. SEC*, 615 F.3d 525, 539 (D.C. Cir. 2010) (quoting Securities Exchange Act Release No. 59039 (December 2, 2008), 73 FR 74770, 74782-83 (December 9, 2008) (SR-NYSEArca-2006-21)).

<sup>11</sup> Securities Exchange Act Release No. 51808 (June 9, 2005), 70 FR 37496, 37499 (June 29, 2005) ("Regulation NMS Adopting Release").

securities by at least 30%. The Exchange believes that the additional month will encourage members who had a lower baseline in November than October to increase their liquidity adding activity on the Exchange to receive the credit, which will improve the overall market quality to the benefit of all market participants.

The Exchange's fee schedule is intended to reflect the Exchange's current assessment of its fees and credits. The Exchange does not currently pay Designated Retail Orders the \$0.0001 and \$0.00015 supplemental credits discussed above. As discussed above, Designated Retail Orders receive their own separate credits on the Exchange's fee schedule and those orders generally receive higher rebates. The Exchange does not commonly provide additional rebates to Designated Retail Orders. Therefore, the Exchange believes it is reasonable to amend its supplemental credits on Tapes A, B and C to accurately reflect that Designated Retail Orders are excluded from the Exchange's payment of these two supplemental credits.

Lastly, the Exchange believes that it is reasonable to provide a member's Designated Retail Orders with the highest rebate that a member qualifies for because the Exchange is always seeking ways to attract more retail order flow. Therefore, if a member's rebate for non-Designated Retail Orders (including any supplemental credits provided in Section 114 and Section 118, except the NBBO Program credit provided in Section 114(g)) is greater than its rebate for Designated Retail Orders (including supplemental credits provided in Section 114 and Section 118), the Exchange is proposing to provide the member with the higher rebate for its Designated Retail Orders. Additionally, the Exchange believes that it is reasonable to exclude the NBBO Program when calculating a member's highest rebate because, as discussed above, the NBBO Program only applies to displayed orders in securities priced at \$1 or more per share that provide liquidity, establish the national best bid or best offer ("NBBO"), and display a quantity of at least one round lot at the time of execution. Consistent with the proposed rule, the NBBO Program explicitly excludes Designated Retail Orders. The Exchange is proposing this change to ensure that none of its members are disadvantaged and that all members can obtain the maximum possible rebate.

The Exchange notes that those market participants that are dissatisfied with the proposals are free to shift their order flow to competing venues that offer

more generous pricing or less stringent qualifying criteria.

#### The Proposal Is an Equitable Allocation of Credits

The Exchange believes its proposal will allocate its charges and credits fairly among its market participants.

The Exchange believes that it is an equitable allocation to establish an additional threshold for its QMM Program's Tier 1 supplemental credit and to include the option of an additional baseline month to measure whether a member qualifies for the \$0.0001 per share executed supplemental credit for displayed quotes/orders (other than Supplemental Orders or Designated Retail Orders) that provide liquidity. The proposals will encourage members to increase the extent to which they add liquidity to the Exchange. To the extent that the Exchange succeeds in increasing the levels of liquidity and activity on the Exchange, then the Exchange will experience improvements in its market quality, which stands to benefit all market participants.

The Exchange also believes that it is equitable to amend the \$0.0001 per share executed and the \$0.00015 per share executed supplemental credits for displayed quotes/orders (other than Supplemental Orders) by applying the credits to members for displayed quotes/orders [sic], which accurately reflect the most current application of these two supplemental credits. The Exchange believes that it is equitable to exclude Designated Retail Orders from these supplemental credits because Designated Retail Orders receive their own separate credits on the Exchange's fee schedule and those orders generally receive higher rebates. The Exchange does not commonly provide additional rebates to Designated Retail Orders.

Lastly, the Exchange also believes it is equitable to allow a member to receive the higher credit if the member's total credits for non-Designated Retail Orders (including any supplemental credits provided in Section 114 and Section 118, except the NBBO Program credit provided in Section 114(g)) is greater than its credit for Designated Retail Orders (including supplemental credits provided in Section 114 and Section 118) in order to encourage firms to continue to provide retail order flow even if the firms expect to receive a higher rebate from their non-Designated Retail Orders. Moreover, the Exchange also believes it is equitable to exclude the NBBO Program from the calculation to ensure that the Exchange does not inadvertently disadvantage any member and that all members are treated

equitably by obtaining the maximum rebate possible. Moreover, the Exchange believes that it is equitable to exclude the NBBO Program from this proposal as it remains consistent with the current rules of the program. Additionally, the Exchange expects any impact from this exclusion to be de minimis because Designated Retail Orders do not frequently set the NBBO.

Any participant that is dissatisfied with the proposal is free to shift their order flow to competing venues that provide more generous pricing or less stringent qualifying criteria.

#### The Proposal is Not Unfairly Discriminatory

The Exchange believes that its proposal is not unfairly discriminatory. As an initial matter, the Exchange believes that nothing about its volume-based tiered pricing model is inherently unfair; instead, it is a rational pricing model that is well-established and ubiquitous in today's economy among firms in various industries—from co-branded credit cards to grocery stores to cellular telephone data plans—that use it to reward the loyalty of their best customers that provide high levels of business activity and incent other customers to increase the extent of their business activity. It is also a pricing model that the Exchange and its competitors have long employed with the assent of the Commission. It is fair because it enhances price discovery and improves the overall quality of the equity markets.

The Exchange also believes that its proposal to add an additional threshold for its QMM Program's Tier 1 supplemental credit is not unfairly discriminatory because the additional qualifications will be available to all members. Similarly, the Exchange believes that it is not unfairly discriminatory to include the option of an additional baseline month to measure whether a member qualifies for the \$0.0001 per share executed supplemental credit for displayed quotes/orders (other than Supplemental Orders or Designated Retail Orders) that provide liquidity because the additional qualifications will be available to all members.

Additionally, the Exchange believes that it is not unfairly discriminatory to amend its fee schedule to align with the way the Exchange pays its supplemental credits. Moreover, all non-retail market participants will continue to be entitled to the credits and the amendment will provide market participants with clarity on how certain supplemental credits are paid. Additionally, Designated Retail Orders receive their own separate

credits on the Exchange's fee schedule and those orders generally receive higher rebates.

Lastly, the Exchange believes that its proposals to provide a member with the higher rebate for its Designated Retail Orders if the member's rebate for non-Designated Retail Orders (including any supplemental credits provided in Section 114 and Section 118, except the NBBO Program credit provided in Section 114(g)) is greater than its credit for Designated Retail Orders (including supplemental credits provided in Section 114 and Section 118) is not unfairly discriminatory because the higher rebate option will be available to all members. Moreover, providing members with the higher rebate will ensure that firms are not disincentivized from increasing their retail order flow due to the higher rebate they may receive from their non-Designated Retail Orders. Additionally, exclusion of the NBBO Program credit from the calculation of the higher rebate is also not discriminatory because the exclusion will also apply to all members.

Overall, the proposals stand to improve the overall market quality of the Exchange, to the benefit of all market participants, by incentivizing members to increase the extent of their liquidity provision or activity on the Exchange. Any participant that is dissatisfied with the proposal is free to shift their order flow to competing venues that provide more generous pricing or less stringent qualifying criteria.

#### *B. Self-Regulatory Organization's Statement on Burden on Competition*

The Exchange does not believe that the proposed rule change will impose any burden on competition not necessary or appropriate in furtherance of the purposes of the Act.

#### *Intramarket Competition*

The Exchange does not believe that its proposal will place any category of Exchange participant at a competitive disadvantage.

As noted above, the Exchange's proposals are intended to have market-improving effects, to the benefit of all members. The Exchange notes that its members are free to trade on other venues to the extent they believe that these proposals are not attractive. As one can observe by looking at any market share chart, price competition between exchanges is fierce, with liquidity and market share moving freely between exchanges in reaction to fee and credit changes.

#### *Intermarket Competition*

In terms of inter-market competition, the Exchange notes that it operates in a highly competitive market in which market participants can readily favor competing venues if they deem fee levels at a particular venue to be excessive, or rebate opportunities available at other venues to be more favorable. In such an environment, the Exchange must continually adjust its credits and fees to remain competitive with other exchanges and with alternative trading systems that have been exempted from compliance with the statutory standards applicable to exchanges. Because competitors are free to modify their own credits and fees in response, and because market participants may readily adjust their order routing practices, the Exchange believes that the degree to which credit or fee changes in this market may impose any burden on competition is extremely limited.

The additional proposed thresholds for the Exchange's QMM Program's Tier 1 supplemental credit and the \$0.0001 per share executed supplemental credit for displayed quotes/orders (other than Supplemental Orders or Designated Retail Orders), as well as the allowance for members to receive the better of their Designated Retail Order credit or its non-Designated Retail Order credit, is reflective of this competition. Moreover, aligning the Exchange's fee schedule with the Exchange's application of its rebates does not burden competition. Any participant that is dissatisfied with the proposals is free to shift their order flow to competing venues that provide more generous pricing or less stringent qualifying criteria.

Even as one of the largest U.S. equities exchanges by volume, the Exchange has less than 20% market share, which in most markets could hardly be categorized as having enough market power to burden competition. Moreover, as noted above, price competition between exchanges is fierce, with liquidity and market share moving freely between exchanges in reaction to fee and credit changes. This is in addition to free flow of order flow to and among off-exchange venues which comprises upwards of 50% of industry volume.

In sum, if the change proposed herein is unattractive to market participants, it is likely that the Exchange will lose market share as a result. Accordingly, the Exchange does not believe that the proposed change will impair the ability of members or competing order execution venues to maintain their

competitive standing in the financial markets.

#### *C. Self-Regulatory Organization's Statement on Comments on the Proposed Rule Change Received From Members, Participants, or Others*

No written comments were either solicited or received.

#### **III. Date of Effectiveness of the Proposed Rule Change and Timing for Commission Action**

Pursuant to Section 19(b)(3)(A)(ii) of the Act,<sup>12</sup> the Exchange has designated this proposal as establishing or changing a due, fee, or other charge imposed by the self-regulatory organization on any person, whether or not the person is a member of the self-regulatory organization, which renders the proposed rule change effective upon filing.

At any time within 60 days of the filing of the proposed rule change, the Commission summarily may temporarily suspend such rule change if it appears to the Commission that such action is: (i) Necessary or appropriate in the public interest; (ii) for the protection of investors; or (iii) otherwise in furtherance of the purposes of the Act. If the Commission takes such action, the Commission shall institute proceedings to determine whether the proposed rule should be approved or disapproved.

#### **IV. Solicitation of Comments**

Interested persons are invited to submit written data, views, and arguments concerning the foregoing, including whether the proposed rule change is consistent with the Act. Comments may be submitted by any of the following methods:

##### *Electronic Comments*

- Use the Commission's internet comment form (<http://www.sec.gov/rules/sro.shtml>); or
- Send an email to [rule-comments@sec.gov](mailto:rule-comments@sec.gov). Please include File Number SR-NASDAQ-2022-011 on the subject line.

##### *Paper Comments*

- Send paper comments in triplicate to Secretary, Securities and Exchange Commission, 100 F Street NE, Washington, DC 20549-1090.
- All submissions should refer to File Number SR-NASDAQ-2022-011. This file number should be included on the subject line if email is used. To help the Commission process and review your comments more efficiently, please use only one method. The Commission will post all comments on the Commission's

<sup>12</sup> 15 U.S.C. 78s(b)(3)(A)(ii).

internet website (<http://www.sec.gov/rules/sro.shtml>). Copies of the submission, all subsequent amendments, all written statements with respect to the proposed rule change that are filed with the Commission, and all written communications relating to the proposed rule change between the Commission and any person, other than those that may be withheld from the public in accordance with the provisions of 5 U.S.C. 552, will be available for website viewing and printing in the Commission's Public Reference Room, 100 F Street NE, Washington, DC 20549, on official business days between the hours of 10:00 a.m. and 3:00 p.m. Copies of the filing also will be available for inspection and copying at the principal office of the Exchange. All comments received will be posted without change. Persons submitting comments are cautioned that we do not redact or edit personal identifying information from comment submissions. You should submit only information that you wish to make available publicly. All submissions should refer to File Number SR-NASDAQ-2022-011 and should be submitted on or before February 24, 2022.

For the Commission, by the Division of Trading and Markets, pursuant to delegated authority.<sup>13</sup>

**J. Matthew DeLesDernier,**  
Assistant Secretary.

[FR Doc. 2022-02183 Filed 2-2-22; 8:45 am]

**BILLING CODE 8011-01-P**

**SMALL BUSINESS ADMINISTRATION**

[License No. 07/07-0112]

**Eagle Fund II, L.P.; Surrender of License of Small Business Investment Company**

Pursuant to the authority granted to the United States Small Business Administration under the Small Business Investment Act of 1958, as amended, under Section 309 of the Act and Section 107.1900 of the Small Business Administration Rules and Regulations (13 CFR 107.1900) to function as a small business investment company under the Small Business Investment Company License No. 07/07-0112 issued to Eagle Fund II, L.P., said license is hereby declared null and void.

United States Small Business Administration.

**Bailey DeVries,**  
Associate Administrator, Office of Investment and Innovation.

[FR Doc. 2022-02222 Filed 2-2-22; 8:45 am]

**BILLING CODE P**

**SMALL BUSINESS ADMINISTRATION**

[Disaster Declaration #17328 and #17329; Hawaii Disaster Number HI-00067]

**Administrative Declaration of a Disaster for the State of Hawaii**

**AGENCY:** Small Business Administration.

**ACTION:** Notice.

**SUMMARY:** This is a notice of an Administrative declaration of a disaster for the State of HAWAII dated 01/28/2022.

*Incident:* Severe Storms, Flooding and Landslides.

*Incident Period:* 12/05/2021 through 12/10/2021.

**DATES:** Issued on 01/28/2022.

*Physical Loan Application Deadline Date:* 03/29/2022.

*Economic Injury (EIDL) Loan Application Deadline Date:* 10/28/2022.

**ADDRESSES:** Submit completed loan applications to: U.S. Small Business Administration, Processing and Disbursement Center, 14925 Kingsport Road, Fort Worth, TX 76155.

**FOR FURTHER INFORMATION CONTACT:** A. Escobar, Office of Disaster Assistance, U.S. Small Business Administration, 409 3rd Street SW, Suite 6050, Washington, DC 20416, (202) 205-6734.

**SUPPLEMENTARY INFORMATION:** Notice is hereby given that as a result of the Administrator's disaster declaration, applications for disaster loans may be filed at the address listed above or other locally announced locations.

The following areas have been determined to be adversely affected by the disaster:

*Primary Areas:* City and County of Honolulu, Maui.

*Contiguous Counties:*

Hawaii:  
Kalawao.

The Interest Rates are:

	Percent
<i>For Physical Damage:</i>	
Homeowners with Credit Available Elsewhere .....	2.875
Homeowners without Credit Available Elsewhere .....	1.438
Businesses with Credit Available Elsewhere .....	5.660
Businesses without Credit Available Elsewhere .....	2.830

	Percent
Non-Profit Organizations with Credit Available Elsewhere ...	1.875
Non-Profit Organizations without Credit Available Elsewhere .....	1.875
<i>For Economic Injury:</i>	
Businesses & Small Agricultural Cooperatives without Credit Available Elsewhere .....	2.830
Non-Profit Organizations without Credit Available Elsewhere .....	1.875

The number assigned to this disaster for physical damage is 17328 6 and for economic injury is 17329 0.

The State which received an EIDL Declaration # is Hawaii.

(Catalog of Federal Domestic Assistance Number 59008)

**Isabella Guzman,**  
Administrator.

[FR Doc. 2022-02191 Filed 2-2-22; 8:45 am]

**BILLING CODE 8026-03-P**

**SMALL BUSINESS ADMINISTRATION**

[Disaster Declaration #17330 and #17331; WASHINGTON Disaster Number WA-00102]

**Presidential Declaration of a Major Disaster for Public Assistance Only for the State of Washington**

**AGENCY:** Small Business Administration.

**ACTION:** Notice.

**SUMMARY:** This is a Notice of the Presidential declaration of a major disaster for Public Assistance Only for the State of WASHINGTON (FEMA-4635-DR), dated 01/27/2022.

*Incident:* Severe Storms, Straight-line Winds, Flooding, Landslides, and Mudslides.

*Incident Period:* 11/05/2021 through 12/02/2021.

**DATES:** Issued on 01/27/2022.

*Physical Loan Application Deadline Date:* 03/28/2022.

*Economic Injury (EIDL) Loan Application Deadline Date:* 10/27/2022.

**ADDRESSES:** Submit completed loan applications to: U.S. Small Business Administration, Processing and Disbursement Center, 14925 Kingsport Road, Fort Worth, TX 76155.

**FOR FURTHER INFORMATION CONTACT:** A. Escobar, Office of Disaster Assistance, U.S. Small Business Administration, 409 3rd Street SW, Suite 6050, Washington, DC 20416, (202) 205-6734.

**SUPPLEMENTARY INFORMATION:** Notice is hereby given that as a result of the President's major disaster declaration on 01/27/2022, Private Non-Profit

<sup>13</sup> 17 CFR 200.30-3(a)(12).

organizations that provide essential services of a governmental nature may file disaster loan applications at the address listed above or other locally announced locations.

The following areas have been determined to be adversely affected by the disaster:

Primary Areas: Clallam, Island, Jefferson, Lewis, San Juan, Skagit, and Whatcom Counties, the Hoh Indian Tribe, Lummi Tribe of the Lummi Reservation, Nooksack Indian Tribe of Washington, Quileute Tribe, and the Swinomish Indian Community.

The Interest Rates are:

	Percent
<i>For Physical Damage:</i> Non-Profit Organizations with Credit Available Elsewhere ... Non-Profit Organizations without Credit Available Elsewhere. 1.875.	1.875
<i>For Economic Injury:</i> Non-Profit Organizations without Credit Available Elsewhere .....	1.875

The number assigned to this disaster for physical damage is 17330 6 and for economic injury is 17331 0.

(Catalog of Federal Domestic Assistance Number 59008)

Barbara Carson, Deputy Associate Administrator for Disaster Assistance.

[FR Doc. 2022-02193 Filed 2-2-22; 8:45 am]

BILLING CODE 8026-03-P

SMALL BUSINESS ADMINISTRATION

Military Reservist Economic Injury Disaster Loans; Interest Rate for Second Quarter FY 2022

AGENCY: Small Business Administration.

ACTION: Notice.

SUMMARY: This is a notice of the Military Reservist Economic Injury Disaster Loans interest rate for loans approved on or after January 28, 2022.

DATES: Issued on 01/28/2022.

FOR FURTHER INFORMATION CONTACT: A. Escobar, Office of Disaster Assistance, U.S. Small Business Administration, 409 3rd Street SW, Suite 6050, Washington, DC 20416, (202) 205-6734.

SUPPLEMENTARY INFORMATION: The Small Business Administration publishes an interest rate for Military Reservist Economic Injury Disaster Loans (13 CFR 123.512) on a quarterly basis. The

interest rate will be 2.940 for loans approved on or after January 28, 2022.

Barbara Carson, Deputy Associate Administrator for Disaster Assistance.

[FR Doc. 2022-02190 Filed 2-2-22; 8:45 am]

BILLING CODE 8026-03-P

SMALL BUSINESS ADMINISTRATION

[Disaster Declaration #17301 and #17302; WASHINGTON Disaster Number WA-00100]

Presidential Declaration of a Major Disaster for the State of Washington

AGENCY: Small Business Administration.

ACTION: Amendment 1.

SUMMARY: This is an amendment of the Presidential declaration of a major disaster for the State of Washington (FEMA-4635-DR), dated 01/05/2022.

Incident: Severe Storms, Straight-line Winds, Flooding, Landslides, and Mudslides.

Incident Period: 11/05/2021 through 12/02/2021.

DATES: Issued on 01/27/2022.

Physical Loan Application Deadline Date: 03/07/2022.

Economic Injury (EIDL) Loan Application Deadline Date: 10/05/2022.

ADDRESSES: Submit completed loan applications to: U.S. Small Business Administration, Processing and Disbursement Center, 14925 Kingsport Road, Fort Worth, TX 76155.

FOR FURTHER INFORMATION CONTACT: A. Escobar, Office of Disaster Assistance, U.S. Small Business Administration, 409 3rd Street SW, Suite 6050, Washington, DC 20416, (202) 205-6734.

SUPPLEMENTARY INFORMATION: The notice of the President's major disaster declaration for the State of Washington, dated 01/05/2022, is hereby amended to change the incident for this disaster to Severe Storms, Straight-line Winds, Flooding, Landslides, and Mudslides. This disaster declaration is also amended to re-establish the incident period for this disaster as beginning 11/05/2021 through and including 12/02/2021.

All other information in the original declaration remains unchanged.

(Catalog of Federal Domestic Assistance Number 59008)

Barbara Carson, Deputy Associate Administrator for Disaster Assistance.

[FR Doc. 2022-02196 Filed 2-2-22; 8:45 am]

BILLING CODE 8026-03-P

DEPARTMENT OF STATE

[Public Notice: 11637]

Privacy Act of 1974; System of Records

ACTION: Notice of a modified system of records.

SUMMARY: This system supports the Department of State's Office of the Directorate of Defense Trade Controls' (DDTC) mission of controlling the export and temporary import of defense articles and defense services covered by the United States Munitions List (USML).

DATES: In accordance with 5 U.S.C. 552a(e)(4) and (11), this system of records notice is effective upon publication, except for the routine uses that are subject to a 30-day period during which interested persons may submit comments to the Department of State. Please submit any comments by March 1st 2022.

ADDRESSES: Questions can be submitted by mail or email or by calling Eric F. Stein, the Senior Agency Official for Privacy, at (202) 485-2051. If by mail, please write to: U.S Department of State; Office of Global Information Systems; A/GIS; Room 1417, 2201 C St. NW; Washington, DC 20520. If by email, please address the email to the Senior Agency Official for Privacy, Eric F. Stein, at Privacy@state.gov. Please write "Munitions Control Records, State-42" on the envelope or the subject line of your email.

FOR FURTHER INFORMATION CONTACT: Eric F. Stein, Senior Agency Official for Privacy; U.S. Department of State; Office of Global Information Services, A/GIS; Room 1417, 2201 C St. NW; Washington, DC 20520 or by calling (202) 485-2051.

SUPPLEMENTARY INFORMATION: This notice is being modified to reflect the Department of State's move to cloud storage, an Information Technology (IT) modernization, and new OMB guidance. The modified system of records notice includes revisions and additions to the following sections: Authority for Maintenance of the System, System Location, Categories of Individuals, Categories of Records in the System, Routine Uses, Storage, and Safeguards. In addition, the Department of State is taking this opportunity to make minor administrative updates to the notice.

SYSTEM NAME AND NUMBER:

Munitions Control Records, State-42.

SECURITY CLASSIFICATION:

Unclassified and Classified.

**SYSTEM LOCATION:**

(a) Department of State domestic data centers located within the United States, with local infrastructure placed overseas at U.S. Embassies, U.S. Consulates General, and U.S. Consulates; and U.S. Missions, (b) within a government cloud platform provided by the Department of State's Enterprise Server Operations Center (ESOC), 2201 C Street NW, Washington, DC 20520.

**SYSTEM MANAGER(S):**

DDTC Chief Information Officer; 2401 E Street NW, Washington DC 20037; (202) 663-2023; [DDTC-CIO@state.gov](mailto:DDTC-CIO@state.gov).

**AUTHORITY FOR MAINTENANCE OF THE SYSTEM:**

22 U.S.C. 2651a (Organization of Department of State); 5 U.S.C. 301 (Departmental Regulations); 22 U.S.C. 2776, 22 U.S.C. 2778, 22 U.S.C. 2779, 22 U.S.C. 2780, and 22 U.S.C. 2751 *et seq.* (Arms Export Control Act); E.O. 13637; International Traffic in Arms Regulations (ITAR), 22 CFR parts 120-130.

**PURPOSE(S) OF THE SYSTEM:**

This system enables DDTC to support industry customers as DDTC performs its mission to implement relevant provisions of the Arms Export Control Act (AECA) and the International Traffic in Arms Regulations (ITAR) and control the export and temporary import of defense articles and defense services covered by the United States Munitions List (USML).

**CATEGORIES OF INDIVIDUALS COVERED BY THE SYSTEM:**

Exporters of defense articles and defense services with or without Department of State authorization; applicants for export licenses; registered exporters; brokers for sales of defense articles or defense services who completed registration statements or submitted requests for approval of a brokering activity; and debarred parties. The Privacy Act defines an individual at 5 U.S.C. 552a(a)(2) as a United States citizen or lawful permanent resident.

**CATEGORIES OF RECORDS IN THE SYSTEM:**

Correspondence, registration statements when a principal executive officer or owner is the same as the applicant, and payment for registration fees sent to the Department of State when an individual or business registers as a manufacturer, exporter and/or broker of defense articles or defense services; information on political contributions, gifts, commissions and fees relating to certain sales of defense articles and defense services; license applicants, secondary entity contacts, third-party points of contact, and other

relevant entities, may be asked to provide information such as: Name, address, nationality/citizenship status, passport/visa/social security number, operator/certificate license, contract and licensing eligibility, contact information (e.g., telephone number, email address), information related to current or past law enforcement charges and convictions, place of birth, financial account numbers, and date of birth; copies of letters to individuals and businesses from the Department of State pertaining to their registration, including notices of suspension and debarment; proposed charging letters and orders and consent agreements pertaining to the Department of State's administrative cases; **Federal Register** Notices of statutory debarment; correspondence, memoranda, federal court documents, telegrams, other government agency reports, and email messages between the Department of State and other federal agencies regarding law enforcement and intelligence information about defense trade activities pertaining to the subject of the record.

**RECORD SOURCE CATEGORIES:**

These records contain information that is primarily obtained from the individual, from the organization the individual represents, federal court documents, and intelligence and law enforcement agencies.

**ROUTINE USES OF RECORDS MAINTAINED IN THE SYSTEM, INCLUDING CATEGORIES OF USERS AND PURPOSES OF SUCH USES:**

Munitions Control Records may be disclosed to:

(a) Appropriate agencies, entities, and persons when (1) the Department of State suspects or has confirmed that there has been a breach of the system of records; (2) the Department of State has determined that as a result of the suspected or confirmed breach there is a risk of harm to individuals, the Department of State (including its information systems, programs, and operations), the Federal Government, or national security; and (3) the disclosure made to such agencies, entities, and persons is reasonably necessary to assist in connection with the Department of State efforts to respond to the suspected or confirmed breach or to prevent, minimize, or remedy such harm.

(b) Another Federal agency or Federal entity, when the Department of State determines that information from this system of records is reasonably necessary to assist the recipient agency or entity in (1) responding to a suspected or confirmed breach or (2) preventing, minimizing, or remedying

the risk of harm to individuals, the recipient agency or entity (including its information systems, programs, and operations), the Federal Government, or national security, resulting from a suspected or confirmed breach.

(c) The Department of Homeland Security, the Department of Justice (DOJ), the Department of Commerce, and other federal entities, including intelligence and law enforcement agencies to assist in their investigations of violations of the AECA or in the context of multilateral or bilateral export regimes.

(d) A court, adjudicative body, or administrative body before which the Department is authorized to appear when (i) the Department; (ii) any employee of the Department in his or her official capacity; (iii) any employee of the Department in his or her individual capacity where the U.S. Department of Justice or the Department has agreed to represent the employee; or (iv) the Government of the United States, when the Department determines that litigation is likely to affect the Department, is a party to litigation or has an interest in such litigation, and the use of such records by the Department is deemed to be relevant and necessary to the litigation or administrative proceeding.

(e) Foreign governments for purposes relating to law enforcement or regulatory matters or in the context of multilateral or bilateral export regimes, in accordance with 22 CFR 126.10(d)(1).

(f) Congress to comply with statutory and regulatory reporting requirements in the AECA or ITAR related to certain defense trade transactions.

(g) Other federal agencies in order to provide independent monitoring of a system of security policy enforcement, malicious activity detection, and security incident response.

(h) The public, as necessary, to comply with statutory or regulatory requirements or to enable exporters to comply with such requirements, as follows:

i. The periodic publication in the **Federal Register** of names, dates of conviction, and months and years of birth of those on the Debarred Parties List pursuant to the authorities granted in 22 U.S.C. 2778(g), as implemented in 22 CFR 127.7.

ii. The periodic publication of charging letters, debarment orders, and orders imposing civil penalties and probationary periods in the Public Reading Room of the Department of State, as required by 22 CFR 128.17, and on the Directorate of Defense Trade Controls website.



iii. The periodic publication of registrant name and address changes on the Directorate of Defense Trade Controls website to assist registrants and applicants in keeping their records current.

The Department of State periodically publishes in the **Federal Register** its Prefatory Statement of Routine Uses. These standard routine uses apply to Munitions Control Records SORN, State-42.

**POLICIES AND PRACTICES FOR STORAGE OF RECORDS:**

Records are stored both in hard copy and on electronic media. A description of standard Department of State policies concerning storage of electronic records is found at <https://fam.state.gov/FAM/05FAM/05FAM0440.html>. All hard copies of records that contain personal information are maintained in secured file cabinets in restricted areas, access to which is limited to authorized personnel.

**POLICIES AND PRACTICES FOR RETRIEVAL OF RECORDS:**

Individual name, company name, DDTC Registration Code, DDTC Case Number.

**POLICIES AND PRACTICES FOR RETENTION AND DISPOSAL OF RECORDS:**

These records will be maintained in accordance with the Department of State Records Schedule, Chapter 24 Arms Control and International Security Records, Office of Defense Trade Controls (A-24-048-01a(1)), as approved by the National Archives and Records Administration (NARA) and outlined at <https://foia.state.gov/Learn/RecordsDisposition.aspx>. More specific information may be obtained by writing to the following address: U.S. Department of State; Director, Office of Information Programs and Services; A/GIS/IPS; 2201 C Street NW, Room B-226; Washington, DC 20520.

**ADMINISTRATIVE, TECHNICAL, AND PHYSICAL SAFEGUARDS:**

All Department of State network users are given cyber security awareness training which covers the procedures for handling Sensitive but Unclassified (SBU) information, including personally identifiable information (PII). Annual refresher training is mandatory. In addition, all Department of State OpenNet network users are required to take the Foreign Service Institute distance learning course instructing employees on privacy and security requirements, including the rules of behavior for handling PII and the potential consequences if it is handled improperly. Before a user is granted

access to Munitions Control Records, they must first be granted access to the Department of State computer network.

Department of State employees and contractors may remotely access this system of records using non-Department of State owned information technology. Such access is subject to approval by the Department of State's mobile and remote access program and is limited to information maintained in unclassified information systems. Remote access to the Department of State's information system is configured in compliance with OMB Circular A-130 multifactor authentication requirements and includes a time-out function.

All Department of State employees and contractors with authorized access to records maintained in this system of records have undergone a thorough background security investigation. Access to the Department of State, its annexes and posts abroad is controlled by security guards and admission is limited to those individuals possessing a valid identification card or individuals under proper escort. Access to computerized files is password-protected and under the direct supervision of the system manager. The system manager has the capability of printing audit trails of access from the computer media, thereby permitting regular and ad hoc monitoring of computer usage. When it is determined that a user no longer needs access, the user account is disabled.

The safeguards in the following paragraphs apply only to records that are maintained in government-certified cloud systems. All cloud systems that provide IT services and process Department of State information must be specifically authorized by the Department of State Authorizing Official and Senior Agency Official for Privacy.

Information that conforms with Department of State-specific definitions for Federal Information Security Modernization Act (FISMA) low, moderate, or high categorization are permissible for cloud usage and must specifically be authorized by the Department of State's Cloud Program Management Office and the Department of State Authorizing Official. Specific security measures and safeguards will depend on the FISMA categorization of the information in a given cloud system. In accordance with Department of State policy, systems that process more sensitive information will require more stringent controls and review by Department of State cybersecurity experts prior to approval. Prior to operation, all Cloud systems must comply with applicable security measures that are outlined in FISMA,

FedRAMP, OMB regulations, National Institute of Standards and Technology's (NIST) Special Publications (SP) and Federal Information Processing Standards (FIPS) and Department of State policies and standards.

All data stored in cloud environments categorized above a low FISMA impact risk level must be encrypted at rest and in-transit using a federally approved encryption mechanism. The encryption keys shall be generated, maintained, and controlled in a Department of State data center by the Department of State key management authority. Deviations from these encryption requirements must be approved in writing by the Department of State Authorizing Official. High FISMA impact risk level systems will additionally be subject to continual auditing and monitoring, multifactor authentication mechanism utilizing Public Key Infrastructure (PKI) and NIST 800 53 controls concerning virtualization, servers, storage and networking, as well as stringent measures to sanitize data from the cloud service once the contract is terminated.

**RECORD ACCESS PROCEDURES:**

Individuals who wish to gain access to or to amend records that pertain to themselves should write to U.S. Department of State; Director, Office of Information Programs and Services; A/GIS/IPS; 2201 C Street NW, Room B-226; Washington, DC 20520. The individual must specify in the written correspondence that he or she wishes the Munitions Control Records to be checked. At a minimum, the individual must include: Full name (including maiden name, if appropriate) and any other names used; current mailing address and zip code; date and place of birth; notarized signature or statement under penalty of perjury that the information in the written is true and correct; a brief description of the circumstances that caused the creation of the record (including the city and/or country and the approximate dates) which gives the individual cause to believe that the Munitions Control Records include records that pertain to the individual. Detailed instructions on Department of State procedures to access and amend records can be found at the Department of State's FOIA website at <https://foia.state.gov/Request/Guide.aspx>.

**CONTESTING RECORD PROCEDURES:**

Individuals who wish to contest records should write to U.S. Department of State; Director, Office of Information Programs and Services; A/GIS/IPS; 2201 C Street NW, Room B-226; Washington, DC 20520.

**NOTIFICATION PROCEDURES:**

Individuals who have reason to believe that this system of records may contain information pertaining to them may write to U.S. Department of State; Director, Office of Information Programs and Services; A/GIS/IPS; 2201 C Street NW, Room B-226; Washington, DC 20520. The individual must specify in the written correspondence that he/she wishes the Munitions Control Records to be checked. At a minimum, the individual must include: Full name (including maiden name, if appropriate) and any other names used; current mailing address and zip code; date and place of birth; notarized signature or statement under penalty of perjury that the information contained in the written correspondence is true and correct; a brief description of the circumstances that caused the creation of the record (including the city and/or country and the approximate dates) which gives the individual cause to believe that the Munitions Control Records include records pertaining to the individual.

**EXEMPTIONS PROMULGATED FOR THE SYSTEM:**

Pursuant to 5 U.S.C. 552a(k)(1) and (k)(2), portions of certain records contained within this system of records are exempted from 5 U.S.C. 552a (c)(3),(d),(e)(1),(3)(4)(G),(H) and (I), and (f). See 22 CFR 171.26.

**HISTORY:**

Previously published at Public Notice 6140 State-42, System Name: Munitions Control Records. Volume 73, Number 55; March 20, 2008.

**Eric F. Stein,**

*Deputy Assistant Secretary, Bureau of Administration, Global Information Services, U.S. Department of State.*

[FR Doc. 2022-02202 Filed 2-2-22; 8:45 am]

**BILLING CODE 4710-25-P**

**DEPARTMENT OF STATE**

[Public Notice: 11642]

**Defense Trade Advisory Group; Notice of Membership**

**ACTION:** Notice.

**SUMMARY:** The U.S. Department of State's Bureau of Political-Military Affairs "the Bureau" is accepting membership applications for the Defense Trade Advisory Group (DTAG). The Bureau is interested in applications from subject matter experts from the United States defense industry, relevant trade and labor associations, and academic and foundation personnel.

**SUPPLEMENTARY INFORMATION:** The DTAG was established as an advisory

committee under the authority of 22 U.S.C. 2656 and the Federal Advisory Committee Act, 5 U.S.C. App. ("FACA"). The purpose of the DTAG is to provide the Bureau of Political-Military Affairs with a formal channel for regular consultation and coordination with U.S. private sector defense exporters and defense trade organizations on issues involving U.S. laws, policies, and regulations for munitions exports. The DTAG advises the Bureau on its support for and regulation of defense trade to help ensure that impediments to legitimate exports are reduced while the foreign policy and national security interests of the United States continue to be protected and advanced in accordance with the Arms Export Control Act (AECA), as amended. Major topics addressed by the DTAG include (a) policy issues on commercial defense trade and technology transfer; (b) regulatory and licensing procedures applicable to defense articles, services, and technical data; (c) technical issues involving the U.S. Munitions List (USML); and (d) questions related to the implementation of the AECA and International Traffic in Arms Regulations (ITAR).

Members are appointed by the Assistant Secretary of State for Political-Military Affairs on the basis of individual qualifications and technical expertise. Past members include representatives of the U.S. defense industry, relevant trade and labor associations, and academic and foundation personnel. In accordance with the DTAG Charter, all DTAG members must be U.S. citizens. DTAG members are expected to serve a consecutive two-year term, which may be renewed or terminated at the discretion of the Assistant Secretary of State for Political-Military Affairs. DTAG members are expected to represent the views of their organizations, while also demonstrating an appreciation for the Department's mission to ensure that commercial exports of defense articles and defense services advance U.S. national security and foreign policy objectives. DTAG members are expected to understand complex issues related to commercial defense trade and industrial competitiveness and are expected to advise the Bureau on these matters.

DTAG members' responsibilities include:

- Making recommendations in accordance with the DTAG Charter and the FACA.
- Making policy and technical recommendations within the scope of the U.S. commercial export control

regime as set forth in the AECA, the ITAR, and appropriate directives.

Please note that DTAG members may not be reimbursed for travel, per diem, and other expenses incurred in connection with their duties as DTAG members.

*How to apply:* Applications in response to this notice must contain the following information: (1) Name of applicant; (2) affirmation of U.S. citizenship; (3) organizational affiliation and title, as appropriate; (4) mailing address; (5) work telephone number; (6) email address; (7) resume; and (8) summary of qualifications for DTAG membership.

This information may be provided via two methods:

- *Emailed to the following address: DTAG@State.Gov.* In the subject field, please write, "DTAG Membership Application."

- *Sent in hardcopy to the following address:* Pecolia Henderson, PM/DDTC, SA-1, 12th Floor, Directorate of Defense Trade Controls, Bureau of Political-Military Affairs, U.S. Department of State, Washington, DC 20522-0112. If sent via regular mail, we recommend you call Ms. Henderson (202-663-2748) to confirm she has received your package.

All applications must be postmarked by February 25, 2022.

**Michael F. Miller,**

*Alternate Designated Federal Officer, Defense Trade Advisory Group, U.S. Department of State.*

[FR Doc. 2022-02266 Filed 2-2-22; 8:45 am]

**BILLING CODE 4710-25-P**

**DEPARTMENT OF STATE**

[Public Notice 11644]

**Notice of Determinations; Additional Culturally Significant Objects Being Imported for Exhibition—  
Determinations: "Persia: Ancient Iran and the Classical World" Exhibition**

**SUMMARY:** On January 28, 2020, notice was published on page 5065 of the **Federal Register** (volume 85, number 18) of determinations pertaining to certain objects to be included in an exhibition entitled "The Classical World in Context: Persia." Notice is hereby given of the following determinations: I hereby determine that certain additional objects being imported from abroad pursuant to agreements with their foreign owners or custodians for temporary display in the retitled exhibition "Persia: Ancient Iran and the Classical World" at The J. Paul Getty Museum at the Getty Villa, Pacific

Palisades, California, and at possible additional exhibitions or venues yet to be determined, are of cultural significance, and, further, that their temporary exhibition or display within the United States as aforementioned is in the national interest. I have ordered that Public Notice of these determinations be published in the **Federal Register**.

**FOR FURTHER INFORMATION CONTACT:** Chi D. Tran, Program Administrator, Office of the Legal Adviser, U.S. Department of State (telephone: 202-632-6471; email: [section2459@state.gov](mailto:section2459@state.gov)). The mailing address is U.S. Department of State, L/PD, 2200 C Street NW (SA-5), Suite 5H03, Washington, DC 20522-0505.

**SUPPLEMENTARY INFORMATION:** The foregoing determinations were made pursuant to the authority vested in me by the Act of October 19, 1965 (79 Stat. 985; 22 U.S.C. 2459), E.O. 12047 of March 27, 1978, the Foreign Affairs Reform and Restructuring Act of 1998 (112 Stat. 2681, *et seq.*; 22 U.S.C. 6501 note, *et seq.*), Delegation of Authority No. 234 of October 1, 1999, Delegation of Authority No. 236-3 of August 28, 2000, and Delegation of Authority No. 523 of December 22, 2021.

**Stacy E. White,**

*Deputy Assistant Secretary for Professional and Cultural Exchanges, Bureau of Educational and Cultural Affairs, Department of State.*

[FR Doc. 2022-02205 Filed 2-2-22; 8:45 am]

**BILLING CODE 4710-05-P**

## DEPARTMENT OF TRANSPORTATION

### Federal Aviation Administration

#### Flight Path Management Advisory Circular

**AGENCY:** Federal Aviation Administration (FAA), Department of Transportation (DOT).

**ACTION:** Notice of availability; request for comments.

**SUMMARY:** This notice announces the availability of a draft advisory circular on flight path management. The FAA invites public comment on AC 120-FPM.

**DATES:** The FAA must receive comments on these proposed documents by March 7, 2022.

**ADDRESSES:** The draft AC 120-FPM can be viewed and comments submitted through the FAA Draft Documents website.

**FOR FURTHER INFORMATION CONTACT:** Joshua Jackson, Flight Standards, Air

Transportation Division, Training and Simulation Group (AFS-280), [Joshua.Jackson@faa.gov](mailto:Joshua.Jackson@faa.gov), (202) 267-8166. Federal Aviation Administration, 800 Independence Avenue SW, Washington, DC 20591.

**SUPPLEMENTARY INFORMATION:** Loss of control inflight remains one of the leading causes of accidents. One of the factors that contributes to these accidents is a flightcrew's failure to manage the flight path of the aircraft. The vulnerabilities of flightcrew automation management have been studied for more than two decades with major improvements in design, training, and operational use of onboard systems for flight path management. Despite these improvements, there are still vulnerabilities that should be addressed.

#### Background

The Air Carrier Training Aviation Rulemaking Committee Steering Committee established the Flight Path Management Work Group in 2018 and has since submitted numerous recommendations to the FAA. The FAA developed this advisory circular (AC) based on those recommendations, and it contains guidance and recommended practices for flight path management that can be incorporated into training programs and operational procedures. Flight path management topics addressed in this advisory circular include manual flight operations, managing automated systems, pilot monitoring, and energy management.

#### Comments Invited

The FAA invites public comments on the AC concerning flight path management. The FAA will consider the public comments submitted during this comment period through the FAA's Draft Documents website in finalizing AC 120-FPM.

Issued in Washington, DC.

**Robert C. Carty,**

*Deputy Executive Director, Flight Standards Service.*

[FR Doc. 2022-02180 Filed 2-2-22; 8:45 am]

**BILLING CODE 4910-13-P**

## DEPARTMENT OF TRANSPORTATION

### Federal Aviation Administration

[Docket No. 2021-1188]

#### Agency Information Collection Activities: Requests for Comments; Clearance of Renewed Approval of Information Collection: Notice of Proposed Construction or Alteration, Notice of Actual Construction or Alteration

**AGENCY:** Federal Aviation Administration (FAA), DOT.

**ACTION:** Notice and request for comments.

**SUMMARY:** In accordance with the Paperwork Reduction Act of 1995, FAA invites public comments about our intention to request the Office of Management and Budget (OMB) approval to renew an information collection. The FAA uses the information collected on form 7460-1 to determine the effect a proposed construction or alteration would have on air navigation and the National Airspace System (NAS) and the information collected on form 7460-2 to measure the progress of actual construction.

**DATES:** Written comments should be submitted by April 4, 2022.

**ADDRESSES:** Please send written comments:

*By Electronic Docket:* [www.regulations.gov](http://www.regulations.gov) (Enter docket number into search field).

*By mail:* Obstruction Evaluation Group, ATTN: David Maddox, Federal Aviation Administration, 800 Independence Ave. SW, Room 400 East, Washington, DC 20591.

*By fax:* (202) 395-6974.

**FOR FURTHER INFORMATION CONTACT:** David Maddox by email at: [david.maddox@faa.gov](mailto:david.maddox@faa.gov); phone: (202) 267-4525.

#### SUPPLEMENTARY INFORMATION:

*Public Comments Invited:* You are asked to comment on any aspect of this information collection, including (a) Whether the proposed collection of information is necessary for FAA's performance; (b) the accuracy of the estimated burden; (c) ways for FAA to enhance the quality, utility and clarity of the information collection; and (d) ways that the burden could be minimized without reducing the quality of the collected information. The agency will summarize and/or include your comments in the request for OMB's clearance of this information collection.

*OMB Control Number:* 2120-0001.

**Title:** Notice of Proposed Construction or Alteration, Notice of Actual Construction or Alteration.

**Form Numbers:** FAA Forms 7460–1 and 7460–2.

**Type of Review:** Renewal of an information collection.

**Background:** 49 U.S.C. Section 44718 states that the Secretary of Transportation shall require notice of structures that may affect navigable airspace, air commerce, or air capacity. These notice requirements are contained in 14 CFR 77. The information is collected via FAA Forms 7460–1 and 7460–2.

**Respondents:** Approximately 85,000 registered respondents including individuals or organizations that propose construction or alteration projects and are required to provide adequate notification to the FAA of that construction or alteration.

**Frequency:** Information is collected on occasion.

**Estimated Average Burden per Response:** Approximately 15 Minutes.

**Estimated Total Annual Burden:** 55,058 hours.

Issued in Washington, DC, on December 13, 2021.

**Michael Helvey,**

*Obstruction Evaluation Group Manager, AJV-A500.*

[FR Doc. 2022–02188 Filed 2–2–22; 8:45 am]

**BILLING CODE 4910–13–P**

## DEPARTMENT OF TRANSPORTATION

### Federal Motor Carrier Safety Administration

[Docket No. FMCSA–2022–0012]

#### Qualification of Drivers; Exemption Applications; Vision

**AGENCY:** Federal Motor Carrier Safety Administration (FMCSA), Department of Transportation (DOT).

**ACTION:** Notice of applications for exemption; request for comments.

**SUMMARY:** FMCSA announces receipt of applications from 12 individuals for an exemption from the vision requirement in the Federal Motor Carrier Safety Regulations (FMCSRs) to operate a commercial motor vehicle (CMV) in interstate commerce. If granted, the exemptions will enable these individuals to operate CMVs in interstate commerce without meeting the vision requirement in one eye.

**DATES:** Comments must be received on or before March 7, 2022.

**ADDRESSES:** You may submit comments identified by the Federal Docket

Management System (FDMS) Docket No. FMCSA–2022–0012 using any of the following methods:

- **Federal eRulemaking Portal:** Go to [www.regulations.gov/](http://www.regulations.gov/), insert the docket number, FMCSA–2022–0012, in the keyword box, and click “Search.” Next, sort the results by “Posted (Newer-Older),” choose the first notice listed, and click on the “Comment” button. Follow the online instructions for submitting comments.

- **Mail:** Dockets Operations; U.S. Department of Transportation, 1200 New Jersey Avenue SE, West Building Ground Floor, Room W12–140, Washington, DC 20590–0001.

- **Hand Delivery:** West Building Ground Floor, Room W12–140, 1200 New Jersey Avenue SE, Washington, DC, between 9 a.m. and 5 p.m., ET, Monday through Friday, except Federal Holidays.

- **Fax:** (202) 493–2251.

To avoid duplication, please use only one of these four methods. See the “Public Participation” portion of the **SUPPLEMENTARY INFORMATION** section for instructions on submitting comments.

**FOR FURTHER INFORMATION CONTACT:** Ms. Christine A. Hydock, Chief, Medical Programs Division, (202) 366–4001, [fmcamedical@dot.gov](mailto:fmcamedical@dot.gov), FMCSA, DOT, 1200 New Jersey Avenue SE, Room W64–224, Washington, DC 20590–0001. Office hours are 8:30 a.m. to 5 p.m., ET, Monday through Friday, except Federal holidays. If you have questions regarding viewing or submitting material to the docket, contact Dockets Operations, (202) 366–9826.

#### SUPPLEMENTARY INFORMATION:

##### I. Public Participation

###### A. Submitting Comments

If you submit a comment, please include the docket number for this notice (Docket No. FMCSA–2022–0012), indicate the specific section of this document to which each comment applies, and provide a reason for each suggestion or recommendation. You may submit your comments and material online or by fax, mail, or hand delivery, but please use only one of these means. FMCSA recommends that you include your name and a mailing address, an email address, or a phone number in the body of your document so that FMCSA can contact you if there are questions regarding your submission.

To submit your comment online, go to [www.regulations.gov/docket?D=FMCSA-2022-0012](http://www.regulations.gov/docket?D=FMCSA-2022-0012). Next, sort the results by “Posted (Newer-Older),” choose the first notice listed, click the “Comment” button, and type your comment into the

text box on the following screen. Choose whether you are submitting your comment as an individual or on behalf of a third party and then submit.

If you submit your comments by mail or hand delivery, submit them in an unbound format, no larger than 8½ by 11 inches, suitable for copying and electronic filing. If you submit comments by mail and would like to know that they reached the facility, please enclose a stamped, self-addressed postcard or envelope.

FMCSA will consider all comments and material received during the comment period.

##### B. Viewing Comments

To view comments go to [www.regulations.gov](http://www.regulations.gov). Insert the docket number, FMCSA–2022–0012, in the keyword box, and click “Search.” Next, sort the results by “Posted (Newer-Older),” choose the first notice listed, and click “Browse Comments.” If you do not have access to the internet, you may view the docket online by visiting Dockets Operations in Room W12–140 on the ground floor of the DOT West Building, 1200 New Jersey Avenue SE, Washington, DC 20590–0001, between 9 a.m. and 5 p.m., ET, Monday through Friday, except Federal holidays. To be sure someone is there to help you, please call (202) 366–9317 or (202) 366–9826 before visiting Dockets Operations.

##### C. Privacy Act

In accordance with 5 U.S.C. 553(c), DOT solicits comments from the public to better inform its rulemaking process. DOT posts these comments, without edit, including any personal information the commenter provides, to [www.regulations.gov](http://www.regulations.gov), as described in the system of records notice (DOT/ALL–14 FDMS), which can be reviewed at [www.transportation.gov/privacy](http://www.transportation.gov/privacy).

##### II. Background

Under 49 U.S.C. 31136(e) and 31315(b), FMCSA may grant an exemption from the FMCSRs for no longer than a 5-year period if it finds such exemption would likely achieve a level of safety that is equivalent to, or greater than, the level that would be achieved absent such exemption. The statute also allows the Agency to renew exemptions at the end of the 5-year period. FMCSA grants medical exemptions from the FMCSRs for a 2-year period to align with the maximum duration of a driver’s medical certification.

The 12 individuals listed in this notice have requested an exemption from the vision requirement in 49 CFR 391.41(b)(10). Accordingly, the Agency

will evaluate the qualifications of each applicant to determine whether granting an exemption will achieve the required level of safety mandated by statute.

The physical qualification standard for drivers regarding vision found in § 391.41(b)(10) states that a person is physically qualified to drive a CMV if that person has distant visual acuity of at least 20/40 (Snellen) in each eye without corrective lenses or visual acuity separately corrected to 20/40 (Snellen) or better with corrective lenses, distant binocular acuity of at least 20/40 (Snellen) in both eyes with or without corrective lenses, field of vision of at least 70° in the horizontal meridian in each eye, and the ability to recognize the colors of traffic signals and devices showing standard red, green, and amber.

On July 16, 1992, the Agency first published the criteria for the Vision Waiver Program, which listed the conditions and reporting standards that CMV drivers approved for participation would need to meet (57 FR 31458). The current Vision Exemption Program was established in 1998, following the enactment of amendments to the statutes governing exemptions made by § 4007 of the Transportation Equity Act for the 21st Century, Public Law 105–178, 112 Stat. 107, 401 (June 9, 1998). Vision exemptions are considered under the procedures established in 49 CFR part 381 subpart C, on a case-by-case basis upon application by CMV drivers who do not meet the vision standards of § 391.41(b)(10).

To qualify for an exemption from the vision requirement, FMCSA requires a person to present verifiable evidence that he/she has driven a commercial vehicle safely in intrastate commerce with the vision deficiency for the past 3 years. Recent driving performance is especially important in evaluating future safety, according to several research studies designed to correlate past and future driving performance. Results of these studies support the principle that the best predictor of future performance by a driver is his/her past record of crashes and traffic violations. Copies of the studies may be found at [www.regulations.gov/docket?D=FMCSA-1998-3637](http://www.regulations.gov/docket?D=FMCSA-1998-3637).

FMCSA believes it can properly apply the principle to monocular drivers, because data from the Federal Highway Administration's former waiver study program clearly demonstrated the driving performance of experienced monocular drivers in the program is better than that of all CMV drivers

collectively.<sup>1</sup> The fact that experienced monocular drivers demonstrated safe driving records in the waiver program supports a conclusion that other monocular drivers, meeting the same qualifying conditions as those required by the waiver program, are also likely to have adapted to their vision deficiency and will continue to operate safely.

The first major research correlating past and future performance was done in England by Greenwood and Yule in 1920. Subsequent studies, building on that model, concluded that crash rates for the same individual exposed to certain risks for two different time periods vary only slightly (See Bates and Neyman, University of California Publications in Statistics, April 1952). Other studies demonstrated theories of predicting crash proneness from crash history coupled with other factors. These factors—such as age, sex, geographic location, mileage driven and conviction history—are used every day by insurance companies and motor vehicle bureaus to predict the probability of an individual experiencing future crashes (See Weber, Donald C., “Accident Rate Potential: An Application of Multiple Regression Analysis of a Poisson Process,” Journal of American Statistical Association, June 1971). A 1964 California Driver Record Study prepared by the California Department of Motor Vehicles concluded that the best overall crash predictor for both concurrent and nonconcurrent events is the number of single convictions. This study used 3 consecutive years of data, comparing the experiences of drivers in the first 2 years with their experiences in the final year.

### III. Qualifications of Applicants

#### *Jacob A. Bigelow*

Mr. Bigelow, 26, has had amblyopia in his left eye since birth. The visual acuity in his right eye is 20/20, and in his left eye, 20/400. Following an examination in 2021, his ophthalmologist stated, “In my medical opinion he had this level of vision his entire life and he has adapted to this and I feel he has vision sufficient to perform the driving tasks required to operate a commercial vehicle.” Mr. Bigelow reported that he has driven straight trucks for 4 years, accumulating 40,000 miles. He holds an operator's license from Wisconsin. His driving record for the last 3 years shows no

crashes and no convictions for moving violations in a CMV.

#### *William H. Brown*

Mr. Brown, 59, has had a retinal detachment in his right eye since 1980. The visual acuity in his right eye is 20/60, and in his left eye, 20/20. Following an examination in 2021, his optometrist stated, “This letter is to certify that William Brown's vision is sufficient to continue driving commercial vehicles with correction.” Mr. Brown reported that he has driven tractor-trailer combinations for 30 years, accumulating 2.55 million miles. He holds a Class A CDL from Oregon. His driving record for the last 3 years shows no crashes and no convictions for moving violations in a CMV.

#### *Ronald L. Butler*

Mr. Butler, 55, has had amblyopia in his left eye since birth. The visual acuity in his right eye is 20/20, and in his left eye, 20/400. Following an examination in 2021, his optometrist stated, “In my medical opinion, Ronald Butler has sufficient vision to perform the driving tasks required to operate a commercial vehicle.” Mr. Butler reported that he has driven tractor-trailer combinations for 25 years, accumulating 2.625 million miles. He holds a Class A CDL from Georgia. His driving record for the last 3 years shows no crashes and no convictions for moving violations in a CMV.

#### *Stephen Butts*

Mr. Butts, 36, has had amblyopia in his left eye since birth. The visual acuity in his right eye is 20/20, and in his left eye, 20/100. Following an examination in 2021, his optometrist stated, “Despite his longstanding visual deficit in his left eye, he has sufficient vision to perform the driving tasks required to operate a commercial vehicle and should be considered to retain his commercial vehicle license.” Mr. Butts reported that he has driven straight trucks for 7 years, accumulating 84,000 miles. He holds an operator's license from Missouri. His driving record for the last 3 years shows no crashes and no convictions for moving violations in a CMV.

#### *Daniel J. Clark*

Mr. Clark, 50, has corneal scarring in his right eye due to a traumatic incident in 2016. The visual acuity in his right eye is light perception, and in his left eye, 20/20. Following an examination in 2021, his ophthalmologist stated, “I feel he can operate a commercial motor vehicle safely and with in restrictions.” Mr. Clark reported that he has driven tractor-trailer combinations for 18 years,

<sup>1</sup> A thorough discussion of this issue may be found in a FHWA final rule published in the **Federal Register** on March 26, 1996 and available on the internet at <https://www.govinfo.gov/content/pkg/FR-1996-03-26/pdf/96-7226.pdf>.

accumulating 1.8 million miles. He holds a Class A CDL from Georgia. His driving record for the last 3 years shows no crashes and no convictions for moving violations in a CMV.

*Kamaljit S. Dhillon*

Mr. Dhillon, 48, has had complete vision loss in his left eye due to a traumatic incident in 1994. The visual acuity in his right eye is 20/20, and in his left eye, no light perception. Following an examination in 2021, his optometrist stated, "His vision and his field of vision in his right eye are excellent and he can therefore safely operate a commercial vehicle." Mr. Dhillon reported that he has driven straight trucks for 10 years, accumulating 680,000 miles, and tractor-trailer combinations for 6 years, accumulating 68,000 miles. He holds a Class A CDL from Ohio. His driving record for the last 3 years shows no crashes and one conviction for a moving violation in a CMV; failing to obey a traffic device.

*Michael P. Gross*

Mr. Gross, 49, has had amblyopia in his left eye since childhood. The visual acuity in his right eye is 20/20, and in his left eye, 20/50. Following an examination in 2021, his optometrist stated, "I certify that, in my medical opinion, Mr. Gross does have sufficient visual performance to perform the visual tasks necessary to operate a commercial vehicle." Mr. Gross reported that he has driven straight trucks for 25 years, accumulating 25 million miles, and tractor-trailer combinations for 6 years, accumulating 30 million miles. He holds a Class A CDL from Utah. His driving record for the last 3 years shows no crashes and no convictions for moving violations in a CMV.

*James Mize*

Mr. Mize, 33, has optic atrophy in his left eye since childhood. The visual acuity in his right eye is 20/20, and in his left eye, 20/400. Following an examination in 2021, his ophthalmologist stated, "In my medical opinion, James Mize has sufficient vision to perform the driving tasks required to operate a commercial vehicle." Mr. Mize reported that he has driven straight trucks for 6 years, accumulating 60,000 miles. He holds a Class A CDL from Tennessee. His driving record for the last 3 years shows no crashes and no convictions for moving violations in a CMV.

*Eugene F. Napieralski*

Mr. Napieralski, 57, has complete vision loss in his left eye since birth. The visual acuity in his right eye is 20/20, and in his left eye, no light perception. Following an examination in 2021, his optometrist stated, "In my professional opinion, Mr. Napieralski has sufficient vision to perform the driving tasks required to operate a commercial vehicle." Mr. Napieralski reported that he has driven straight trucks for 38 years, accumulating 950,000 miles, and tractor-trailer combinations for 2 years, accumulating 20,000 miles. He holds a Class A CDL from Minnesota. His driving record for the last 3 years shows no crashes and no convictions for moving violations in a CMV.

*Gerard L. Pagan*

Mr. Pagan, 61, has had amblyopia in his left eye since childhood. The visual acuity in his right eye is 20/20, and in his left eye, 20/100. Following an examination in 2021, his optometrist stated, "I certify that upon examining Jerry Pagan on 9/9/2021, he has sufficient vision to perform the driving tasks required to operate a commercial vehicle." Mr. Pagan reported that he has driven tractor-trailer combinations for 25 years, accumulating 2 million miles. He holds a Class A CDL from North Carolina. His driving record for the last 3 years shows one crash, which he was not cited for, and no convictions for moving violations in a CMV.

*Sheryl J. Simpson*

Ms. Simpson, 58, has had amblyopia in her left eye since childhood. The visual acuity in her right eye is 20/25, and in her left eye, 20/50. Following an examination in 2021, her optometrist stated, "In my medical opinion, Sheryl has more than sufficient vision to perform the driving tasks required to operate a commercial vehicle." Ms. Simpson reported that she has driven buses for 8 years, accumulating 704,000 miles. She holds a Class B CDL from Texas. Her driving record for the last 3 years shows no crashes and no convictions for moving violations in a CMV.

*Willie J. Smith*

Mr. Smith, 64, has corneal opacity in his right eye due to a traumatic incident in 1985. The visual acuity in his right eye is hand motion, and in his left eye, 20/25. Following an examination in 2021, his optometrist stated, "It is my medical opinion that the patient has sufficient vision to perform the driving tasks required to operate a commercial motor vehicle." Mr. Smith reported that

he has driven tractor-trailer combinations for 40 years, accumulating 2.4 million miles. He holds a Class A CDL from Texas. His driving record for the last 3 years shows no crashes and one conviction for a moving violation in a CMV: speeding.

**IV. Request for Comments**

In accordance with 49 U.S.C. 31136(e) and 31315(b), FMCSA requests public comment from all interested persons on the exemption petitions described in this notice. We will consider all comments and material received before the close of business on the closing date indicated under the **DATES** section of the notice.

**Larry W. Minor,**

*Associate Administrator for Policy.*

[FR Doc. 2022-02204 Filed 2-2-22; 8:45 am]

**BILLING CODE 4910-EX-P**

**DEPARTMENT OF TRANSPORTATION**

**Federal Motor Carrier Safety Administration**

[Docket No. FMCSA-2021-0026]

**Qualification of Drivers; Exemption Applications; Epilepsy and Seizure Disorders**

**AGENCY:** Federal Motor Carrier Safety Administration (FMCSA), Department of Transportation (DOT).

**ACTION:** Notice of applications for exemption; request for comments.

**SUMMARY:** FMCSA announces receipt of applications from 32 individuals for an exemption from the prohibition in the Federal Motor Carrier Safety Regulations (FMCSRs) against persons with a clinical diagnosis of epilepsy or any other condition that is likely to cause a loss of consciousness or any loss of ability to control a commercial motor vehicle (CMV) to drive in interstate commerce. If granted, the exemptions would enable these individuals who have had one or more seizures and are taking anti-seizure medication to operate CMVs in interstate commerce.

**DATES:** Comments must be received on or before March 7, 2022.

**ADDRESSES:** You may submit comments identified by the Federal Docket Management System (FDMS) Docket No. FMCSA-2021-0026 using any of the following methods:

- *Federal eRulemaking Portal:* Go to [www.regulations.gov/](http://www.regulations.gov/), insert the docket number, FMCSA-2021-0026, in the keyword box, and click "Search." Next, sort the results by "Posted (Newer-Older)," choose the first notice listed,

and click on the “Comment” button. Follow the online instructions for submitting comments.

- *Mail:* Dockets Operations; U.S. Department of Transportation, 1200 New Jersey Avenue SE, West Building Ground Floor, Room W12–140, Washington, DC 20590–0001.

- *Hand Delivery:* West Building Ground Floor, Room W12–140, 1200 New Jersey Avenue SE, Washington, DC 20590–0001 between 9 a.m. and 5 p.m., ET, Monday through Friday, except Federal Holidays.

- *Fax:* (202) 493–2251.

To avoid duplication, please use only one of these four methods. See the “Public Participation” portion of the **SUPPLEMENTARY INFORMATION** section for instructions on submitting comments.

**FOR FURTHER INFORMATION CONTACT:** Ms. Christine A. Hydock, Chief, Medical Programs Division, (202) 366–4001, [fmcsamedical@dot.gov](mailto:fmcsamedical@dot.gov), FMCSA, DOT, 1200 New Jersey Avenue SE, Room W64–224, Washington, DC 20590–0001. Office hours are 8:30 a.m. to 5 p.m., ET, Monday through Friday, except Federal holidays. If you have questions regarding viewing or submitting material to the docket, contact Dockets Operations, (202) 366–9826.

#### **SUPPLEMENTARY INFORMATION:**

### **I. Public Participation**

#### *A. Submitting Comments*

If you submit a comment, please include the docket number for this notice (Docket No. FMCSA–2021–0026), indicate the specific section of this document to which each comment applies, and provide a reason for each suggestion or recommendation. You may submit your comments and material online or by fax, mail, or hand delivery, but please use only one of these means. FMCSA recommends that you include your name and a mailing address, an email address, or a phone number in the body of your document so that FMCSA can contact you if there are questions regarding your submission.

To submit your comment online, go to [www.regulations.gov/docket?D=FMCSA-2021-0026](http://www.regulations.gov/docket?D=FMCSA-2021-0026). Next, sort the results by “Posted (Newer-Older),” choose the first notice listed, click the “Comment” button, and type your comment into the text box on the following screen. Choose whether you are submitting your comment as an individual or on behalf of a third party and then submit.

If you submit your comments by mail or hand delivery, submit them in an unbound format, no larger than 8½ by 11 inches, suitable for copying and electronic filing. If you submit

comments by mail and would like to know that they reached the facility, please enclose a stamped, self-addressed postcard or envelope.

FMCSA will consider all comments and material received during the comment period.

#### *B. Viewing Comments*

To view comments go to [www.regulations.gov](http://www.regulations.gov). Insert the docket number, FMCSA–2021–0026, in the keyword box, and click “Search.” Next, sort the results by “Posted (Newer-Older),” choose the first notice listed, and click “Browse Comments.” If you do not have access to the internet, you may view the docket online by visiting Dockets Operations in Room W12–140 on the ground floor of the DOT West Building, 1200 New Jersey Avenue SE, Washington, DC 20590–0001, between 9 a.m. and 5 p.m., ET, Monday through Friday, except Federal holidays. To be sure someone is there to help you, please call (202) 366–9317 or (202) 366–9826 before visiting Dockets Operations.

#### *C. Privacy Act*

In accordance with 5 U.S.C. 553(c), DOT solicits comments from the public to better inform its regulatory process. DOT posts these comments, without edit, including any personal information the commenter provides, to [www.regulations.gov](http://www.regulations.gov), as described in the system of records notice (DOT/ALL–14 FDMS), which can be reviewed at [www.transportation.gov/privacy](http://www.transportation.gov/privacy).

### **II. Background**

Under 49 U.S.C. 31136(e) and 31315(b), FMCSA may grant an exemption from the FMCSRs for no longer than a 5-year period if it finds such exemption would likely achieve a level of safety that is equivalent to, or greater than, the level that would be achieved absent such exemption. The statute also allows the Agency to renew exemptions at the end of the 5-year period. FMCSA grants medical exemptions from the FMCSRs for a 2-year period to align with the maximum duration of a driver’s medical certification.

The 32 individuals listed in this notice have requested an exemption from the epilepsy and seizure disorders prohibition in 49 CFR 391.41(b)(8). Accordingly, the Agency will evaluate the qualifications of each applicant to determine whether granting the exemption will achieve the required level of safety mandated by statute.

The physical qualification standard for drivers regarding epilepsy found in § 391.41(b)(8) states that a person is physically qualified to drive a CMV if

that person has no established medical history or clinical diagnosis of epilepsy or any other condition which is likely to cause the loss of consciousness or any loss of ability to control a CMV.

In addition to the regulations, FMCSA has published advisory criteria<sup>1</sup> to assist medical examiners (MEs) in determining whether drivers with certain medical conditions are qualified to operate a CMV in interstate commerce.

The criteria states that if an individual has had a sudden episode of a non-epileptic seizure or loss of consciousness of unknown cause that did not require anti-seizure medication, the decision whether that person’s condition is likely to cause the loss of consciousness or loss of ability to control a CMV should be made on an individual basis by the ME in consultation with the treating physician. Before certification is considered, it is suggested that a 6-month waiting period elapse from the time of the episode. Following the waiting period, it is suggested that the individual have a complete neurological examination. If the results of the examination are negative and anti-seizure medication is not required, then the driver may be qualified.

In those individual cases where a driver has had a seizure or an episode of loss of consciousness that resulted from a known medical condition (e.g., drug reaction, high temperature, acute infectious disease, dehydration, or acute metabolic disturbance), certification should be deferred until the driver has recovered fully from that condition, has no existing residual complications, and is not taking anti-seizure medication.

Drivers who have a history of epilepsy/seizures, off anti-seizure medication and seizure-free for 10 years, may be qualified to operate a CMV in interstate commerce. Interstate drivers with a history of a single unprovoked seizure may be qualified to drive a CMV in interstate commerce if seizure-free and off anti-seizure medication for a 5-year period or more.

As a result of MEs misinterpreting advisory criteria as regulation, numerous drivers have been prohibited from operating a CMV in interstate commerce based on the fact that they have had one or more seizures and are taking anti-seizure medication, rather than an individual analysis of their circumstances by a qualified ME based

<sup>1</sup> These criteria may be found in APPENDIX A TO PART 391—MEDICAL ADVISORY CRITERIA, section H. *Epilepsy*: § 391.41(b)(8), paragraphs 3, 4, and 5, which is available on the internet at <https://www.gpo.gov/fdsys/pkg/CFR-2015-title49-vol5/pdf/CFR-2015-title49-vol5-part391-appA.pdf>.

on the physical qualification standards and medical best practices.

On January 15, 2013, FMCSA announced in a Notice of Final Disposition titled, "Qualification of Drivers; Exemption Applications; Epilepsy and Seizure Disorders," (78 FR 3069), its decision to grant requests from 22 individuals for exemptions from the regulatory requirement that interstate CMV drivers have "no established medical history or clinical diagnosis of epilepsy or any other condition which is likely to cause loss of consciousness or any loss of ability to control a CMV." Since that time, the Agency has published additional notices granting requests from individuals for exemptions from the regulatory requirement regarding epilepsy found in § 391.41(b)(8).

To be considered for an exemption from the epilepsy and seizure disorders prohibition in § 391.41(b)(8), applicants must meet the criteria in the 2007 recommendations of the Agency's Medical Expert Panel (78 FR 3069).

### III. Qualifications of Applicants

#### *Andrew Anzalone*

Mr. Anzalone is a 24-year old class DM license holder in Massachusetts. He has a history of epilepsy and has been seizure free since 2010. He takes anti-seizure medication with the dosage and frequency remaining the same since 2010. His physician states that he is supportive of Mr. Anzalone receiving an exemption.

#### *Anthony Cavaliere*

Mr. Cavaliere is a 33-year old class BM license holder in New York. He had a generalized cerebral concussion and has been seizure free since 2010. He takes anti-seizure medication with the dosage and frequency remaining the same since 2011. His physician states that he is supportive of Mr. Cavaliere receiving an exemption.

#### *Shane Chacon*

Mr. Chacon is a 53-year old class A license holder in Idaho. He has a history of epilepsy and has been seizure free since 1997. He takes anti-seizure medication with the dosage and frequency remaining the same since 2019. His physician states that he is supportive of Mr. Chacon receiving an exemption.

#### *Brad Crawford*

Mr. Crawford is a 38-year old class E license holder in Louisiana. He has a history of generalized epilepsy and has been seizure free since 2013. He takes anti-seizure medication with the dosage and frequency remaining the same since

2015. His physician states that he is supportive of Mr. Crawford receiving an exemption.

#### *Michael Davee*

Mr. Davee is a 54-year old class C license holder in California. He had a single, provoked seizure in October 2017. He does not take anti-seizure medication. His physician states that he is supportive of Mr. Davee receiving an exemption.

#### *Callon Hegman*

Mr. Hegman is a 26-year old class E license holder in Missouri. He has a history of juvenile absence epilepsy and has been seizure free since 2012. He takes anti-seizure medication with the dosage and frequency remaining the same since 2017. His physician states that he is supportive of Mr. Hegman receiving an exemption.

#### *Jacob Hitchcock*

Mr. Hitchcock is a 31-year old class C license holder in Iowa. He has a history of non-intractable epilepsy and has been seizure free since May 2010. He takes anti-seizure medication with the dosage and frequency remaining the same since 2010. His physician states that he is supportive of Mr. Hitchcock receiving an exemption.

#### *Holly Hobert*

Ms. Hobert is a 27-year old class O license holder in Nebraska. He has a history of generalized epilepsy and has been seizure free since 2013. He takes anti-seizure medication with the dosage and frequency remaining the same since 2016. His physician states that he is supportive of Ms. Hobert receiving an exemption.

#### *Gary Johnson*

Mr. Johnson is a 49-year old class E license holder in Missouri. He has a history of chronic epilepsy and has been seizure free since March 2012. He takes anti-seizure medication with the dosage and frequency remaining the same since 2015. His physician states that he is supportive of Mr. Johnson receiving an exemption.

#### *Gregory Johnson*

Mr. Johnson is a 44-year old class C license holder in North Carolina. He has a history of seizures and has been seizure free since June 2011. He takes anti-seizure medication with the dosage and frequency remaining the same since 2013. His physician states that he is supportive of Mr. Johnson receiving an exemption.

#### *Lance Johnson*

Mr. Johnson is a 54-year old class D license holder in Tennessee. He has a history of complex partial seizures and has been seizure free since 2009. He takes anti-seizure medication with the dosage and frequency remaining the same since 2018. His physician states that he is supportive of Mr. Johnson receiving an exemption.

#### *Alan Keil*

Mr. Keil is a 45-year old class three license holder in Hawaii. He has a history of epilepsy and has been seizure free for more than 10 years. He takes anti-seizure medication with the dosage and frequency remaining the same since 2011. His physician states that he is supportive of Mr. Keil receiving an exemption.

#### *Kim Langan*

Mr. Langan is a 59-year old class CM license holder in California. He has a history of epilepsy and has been seizure free since 2013. He takes anti-seizure medication with the dosage and frequency remaining the same since 2015. His physician states that he is supportive of Mr. Langan receiving an exemption.

#### *Armando Macias-Tovar*

Mr. Macias-Tovar is a 34-year old class E license holder in Florida. He has a history of generalized epilepsy and has been seizure free since 2013. He takes anti-seizure medication with the dosage and frequency remaining the same since 2011. His physician states that he is supportive of Mr. Macias-Tovar receiving an exemption.

#### *Christian Mandahl*

Mr. Mandahl is a 31-year old class D license holder in Montana. He has a history of primary generalized epilepsy and has been seizure free since 2012. He takes anti-seizure medication with the dosage and frequency remaining the same since 2012. His physician states that he is supportive of Mr. Mandahl receiving an exemption.

#### *Joseph Mendoza*

Mr. Mendoza is a 48-year old operator license holder in Indiana. He has a history of seizure disorder and has been seizure free since 1996. He takes anti-seizure medication with the dosage and frequency remaining the same since 2013. His physician states that he is supportive of Mr. Mendoza receiving an exemption.

#### *Edna Merritt*

Ms. Merritt is a 59-year old class D license holder in Tennessee. She has a



history of partial complex seizure disorder and has been seizure free since 2010. She takes anti-seizure medication with the dosage and frequency remaining the same since 2007. Her physician states that he is supportive of Ms. Merritt receiving an exemption.

*Richard Packer*

Mr. Packer is a 33-year old class A license holder in Idaho. He has a history of non-intractable generalized idiopathic epilepsy and has been seizure free since 2003. He takes anti-seizure medication with the dosage and frequency remaining the same since 2003. His physician states that he is supportive of Mr. Packer receiving an exemption.

*Alexander Paradis*

Mr. Paradis is a 24-year old class 10 license holder in Rhode Island. He has a history of focal epilepsy and has been seizure free since 2010. He takes anti-seizure medication with the dosage and frequency remaining the same since 2016. His physician states that he is supportive of Mr. Paradis receiving an exemption.

*Steven Paul*

Mr. Paul is a 60-year old class DM license holder in Wisconsin. He has a history of seizure disorder and has been seizure free since 2012. He takes anti-seizure medication with the dosage and frequency remaining the same since 2013. His physician states that he is supportive of Mr. Paul receiving an exemption.

*Kevin Podman*

Mr. Podman is a 48-year old commercial driver's license (CDL) holder in Illinois. He has a history of an unprovoked, one-time, generalized tonic-clonic seizure and has been seizure free since 2014. He takes anti-seizure medication with the dosage and frequency remaining the same since 2014. His physician states that he is supportive of Mr. Podman receiving an exemption.

*Michael Reimer*

Mr. Reimer is a 37-year old class C license holder in California. He has a history of epilepsy and has been seizure free since 2012. He takes anti-seizure medication with the dosage and frequency remaining the same since 2012. His physician states that he is supportive of Mr. Reimer receiving an exemption.

*Richard Riley*

Mr. Riley is a 66-year old class A license holder in Iowa. He has a history

of a single generalized nocturnal seizure and has been seizure free since August 6, 2020. He takes anti-seizure medication with the dosage and frequency remaining the same since August 6, 2020. His physician states that he is supportive of Mr. Riley receiving an exemption.

*Charles Rivet*

Mr. Rivet is a 43-year old class 10 license holder in Iowa. He has a history of complex partial seizure disorder and has been seizure free since 2013. He takes anti-seizure medication with the dosage and frequency remaining the same since 2012. His physician states that he is supportive of Mr. Rivet receiving an exemption.

*Brian Runk*

Mr. Runk is a 31-year old class A license holder in Pennsylvania. He has a history of a single, unprovoked, nocturnal seizure and has been seizure free since 2016. He takes anti-seizure medication with the dosage and frequency remaining the same since 2017. His physician states that he is supportive of Mr. Runk receiving an exemption.

*Lucas Schmidt*

Mr. Schmidt is a 41-year old class D license holder in New York. He has a history of epilepsy and has been seizure free since 1997. He takes anti-seizure medication with the dosage and frequency remaining the same for more than 10 years. His physician states that he is supportive of Mr. Schmidt receiving an exemption.

*Bradley Scruggs*

Mr. Scruggs is a 27-year old class A license holder in California. He has a history of focal awareness seizures and has been seizure free since 2007. He takes anti-seizure medication with the dosage and frequency remaining the same since 2015. His physician states that he is supportive of Mr. Scruggs receiving an exemption.

*Kacen Shaffer*

Mr. Shaffer is a 22-year old class R license holder in Colorado. He has a history of epilepsy and has been seizure free since 2013. He takes anti-seizure medication with the dosage and frequency remaining the same since 2014. His physician states that he is supportive of Mr. Shaffer receiving an exemption.

*Shaen Smith*

Mr. Smith is a 53-year old class D license holder in Minnesota. He has a history of localization-related epilepsy

and has been seizure free since 1998. He takes anti-seizure medication with the dosage and frequency remaining the same since 2015. His physician states that he is supportive of Mr. Smith receiving an exemption.

*Kip West*

Mr. West is a 53-year old class R license holder in Colorado. He has a history of seizures and has been seizure free since 1985. He takes anti-seizure medication with the dosage and frequency remaining the same since 1985. His physician states that he is supportive of Mr. West receiving an exemption.

*Derek Wettstein*

Mr. Wettstein is a 37-year old class C license holder in Texas. He has a history of idiopathic epilepsy and epileptic syndrome, not intractable, without status epilepticus and has been seizure free since 2004. He takes anti-seizure medication with the dosage and frequency remaining the same since 2004. His physician states that he is supportive of Mr. Wettstein receiving an exemption.

*Jeremy Williams*

Mr. Williams is a 19-year old CDL holder in Mississippi. He has a history of a single unprovoked seizure and has been seizure free since 2017. He takes anti-seizure medication with the dosage and frequency remaining the same since 2018. His physician states that he is supportive of Mr. Williams receiving an exemption.

**IV. Request for Comments**

In accordance with 49 U.S.C. 31136(e) and 31315(b), FMCSA requests public comment from all interested persons on the exemption petitions described in this notice. We will consider all comments received before the close of business on the closing date indicated under the **DATES** section of the notice.

**Larry W. Minor,**

*Associate Administrator for Policy.*

[FR Doc. 2022-02203 Filed 2-2-22; 8:45 am]

**BILLING CODE 4910-EX-P**

**DEPARTMENT OF TRANSPORTATION**

**Federal Motor Carrier Safety Administration**

[Docket No. FMCSA-2022-0031]

**Qualification of Drivers; Exemption Applications; Hearing**

**AGENCY:** Federal Motor Carrier Safety Administration (FMCSA), Department of Transportation (DOT).

**ACTION:** Notice of applications for exemption; request for comments.

**SUMMARY:** FMCSA announces receipt of applications from 23 individuals for an exemption from the hearing requirement in the Federal Motor Carrier Safety Regulations (FMCSRs) to operate a commercial motor vehicle (CMV) in interstate commerce. If granted, the exemptions would enable these hard of hearing and deaf individuals to operate CMVs in interstate commerce.

**DATES:** Comments must be received on or before March 7, 2022.

**ADDRESSES:** You may submit comments identified by the Federal Docket Management System (FDMS) Docket No. FMCSA–2022–0031 using any of the following methods:

- *Federal eRulemaking Portal:* Go to [www.regulations.gov](http://www.regulations.gov), insert the docket number, FMCSA–2022–0031, in the keyword box, and click “Search.” Next, sort the results by “Posted (Newer-Older),” choose the first notice listed, and click on the “Comment” button. Follow the online instructions for submitting comments.

- *Mail:* Dockets Operations; U.S. Department of Transportation, 1200 New Jersey Avenue SE, West Building Ground Floor, Room W12–140, Washington, DC 20590–0001.

- *Hand Delivery:* West Building Ground Floor, Room W12–140, 1200 New Jersey Avenue SE, Washington, DC 20590–0001, between 9 a.m. and 5 p.m., ET, Monday through Friday, except Federal Holidays.

- *Fax:* (202) 493–2251.

To avoid duplication, please use only one of these four methods. See the “Public Participation” portion of the **SUPPLEMENTARY INFORMATION** section for instructions on submitting comments.

**FOR FURTHER INFORMATION CONTACT:** Ms. Christine A. Hydock, Chief, Medical Programs Division, (202) 366–4001, [fmcsamedical@dot.gov](mailto:fmcsamedical@dot.gov), FMCSA, DOT, 1200 New Jersey Avenue SE, Room W64–224, Washington, DC 20590–0001. Office hours are 8:30 a.m. to 5 p.m., ET, Monday through Friday, except Federal holidays. If you have questions regarding viewing or submitting material to the docket, contact Dockets Operations, (202) 366–9826.

**SUPPLEMENTARY INFORMATION:**

**I. Public Participation**

*A. Submitting Comments*

If you submit a comment, please include the docket number for this notice (Docket No. FMCSA–2022–0031), indicate the specific section of this document to which each comment applies, and provide a reason for each

suggestion or recommendation. You may submit your comments and material online or by fax, mail, or hand delivery, but please use only one of these means. FMCSA recommends that you include your name and a mailing address, an email address, or a phone number in the body of your document so that FMCSA can contact you if there are questions regarding your submission.

To submit your comment online, go to [www.regulations.gov/docket?D=FMCSA-2022-0031](http://www.regulations.gov/docket?D=FMCSA-2022-0031). Next, sort the results by “Posted (Newer-Older),” choose the first notice listed, click the “Comment” button, and type your comment into the text box on the following screen. Choose whether you are submitting your comment as an individual or on behalf of a third party and then submit.

If you submit your comments by mail or hand delivery, submit them in an unbound format, no larger than 8½ by 11 inches, suitable for copying and electronic filing. If you submit comments by mail and would like to know that they reached the facility, please enclose a stamped, self-addressed postcard or envelope.

FMCSA will consider all comments and material received during the comment period.

*B. Viewing Comments*

To view comments go to [www.regulations.gov](http://www.regulations.gov). Insert the docket number, FMCSA–2022–0031, in the keyword box, and click “Search.” Next, sort the results by “Posted (Newer-Older),” choose the first notice listed, and click “Browse Comments.” If you do not have access to the internet, you may view the docket online by visiting Dockets Operations in Room W12–140 on the ground floor of the DOT West Building, 1200 New Jersey Avenue SE, Washington, DC 20590–0001, between 9 a.m. and 5 p.m., ET, Monday through Friday, except Federal holidays. To be sure someone is there to help you, please call (202) 366–9317 or (202) 366–9826 before visiting Dockets Operations.

*C. Privacy Act*

In accordance with 5 U.S.C. 553(c), DOT solicits comments from the public to better inform its regulatory process. DOT posts these comments, without edit, including any personal information the commenter provides, to [www.regulations.gov](http://www.regulations.gov), as described in the system of records notice (DOT/ALL–14 FDMS), which can be reviewed at [www.transportation.gov/privacy](http://www.transportation.gov/privacy).

**II. Background**

Under 49 U.S.C. 31136(e) and 31315(b), FMCSA may grant an

exemption from the FMCSRs for no longer than a 5-year period if it finds such exemption would likely achieve a level of safety that is equivalent to, or greater than, the level that would be achieved absent such exemption. The statute also allows the Agency to renew exemptions at the end of the 5-year period. FMCSA grants medical exemptions from the FMCSRs for a 2-year period to align with the maximum duration of a driver’s medical certification.

The 23 individuals listed in this notice have requested an exemption from the hearing requirement in 49 CFR 391.41(b)(11). Accordingly, the Agency will evaluate the qualifications of each applicant to determine whether granting the exemption will achieve the required level of safety mandated by statute.

The physical qualification standard for drivers regarding hearing found in § 391.41(b)(11) states that a person is physically qualified to drive a CMV if that person first perceives a forced whispered voice in the better ear at not less than 5 feet with or without the use of a hearing aid or, if tested by use of an audiometric device, does not have an average hearing loss in the better ear greater than 40 decibels at 500 Hz, 1,000 Hz, and 2,000 Hz with or without a hearing aid when the audiometric device is calibrated to American National Standard (formerly ASA Standard) Z24.5–1951.

This standard was adopted in 1970 and was revised in 1971 to allow drivers to be qualified under this standard while wearing a hearing aid, 35 FR 6458, 6463 (Apr. 22, 1970) and 36 FR 12857 (July 3, 1971).

On February 1, 2013, FMCSA announced in a Notice of Final Disposition titled, “Qualification of Drivers; Application for Exemptions; National Association of the Deaf,” (78 FR 7479), its decision to grant requests from 40 individuals for exemptions from the Agency’s physical qualification standard concerning hearing for interstate CMV drivers. Since that time the Agency has published additional notices granting requests from hard of hearing and deaf individuals for exemptions from the Agency’s physical qualification standard concerning hearing for interstate CMV drivers.

**III. Qualifications of Applicants**

*Yunier Alegre*

Mr. Alegre, 33, holds a class E license in Florida.

*Kenneth Alston*

Mr. Alston, 33, holds a class D license in New Jersey.

*Charles Armand*

Mr. Armand, 39, holds a class A license in New Jersey.

*Baldemar Barba*

Mr. Barba, 24, holds a class C license in Texas.

*Gary Barber*

Mr. Barber, 70, holds a commercial driver's license in Wisconsin.

*Desmond Dantzler*

Mr. Dantzler, 51, holds a class D license in Arizona.

*Jeremy Descloux*

Mr. Descloux, 25, holds an operator's license in Washington.

*Philip Fatigato*

Mr. Fatigato, 28, holds a class D license in Illinois.

*William Hoke*

Mr. Hoke, 50, holds a class D license in New York.

*Edward Larizza*

Mr. Larizza, 24, holds a class C license in California.

*Kevin Maddox*

Mr. Maddox, 58, holds a class AM license in Georgia.

*Bikien McKoy*

Mr. McKoy, 48, holds a class A license in North Carolina.

*Rage Muse*

Mr. Muse, 33, holds a class A license in Minnesota.

*Orlando Padilla*

Mr. Padilla, 47, holds a class E license in Florida.

*Michael Paul*

Mr. Paul, 60, holds a class A license in Illinois.

*Aaron Pitsker*

Mr. Pitsker, 31, holds a class CM license in California.

*Michael Principe*

Mr. Principe, 33, holds a class C license in Texas.

*William Rivas*

Mr. Rivas, 31, holds a class C license in California.

*Kenneth Salts*

Mr. Salts, 45, holds a class D license in Ohio.

*Issac Soto*

Mr. Soto, 32, holds a class D license in Illinois.

*Gary Sturdevant*

Mr. Sturdevant, 43, holds a class CM license in Texas.

*Richard Taulbee*

Mr. Taulbee, 40, holds a class C license in Georgia.

*Matthew Taylor*

Mr. Taylor, 27, holds a class C license in Texas.

**IV. Request for Comments**

In accordance with 49 U.S.C. 31136(e) and 31315(b), FMCSA requests public comment from all interested persons on the exemption petitions described in this notice. We will consider all comments received before the close of business on the closing date indicated under the **DATES** section of the notice.

**Larry W. Minor,**

*Associate Administrator for Policy.*

[FR Doc. 2022-02206 Filed 2-2-22; 8:45 am]

**BILLING CODE 4910-EX-P**

**DEPARTMENT OF TRANSPORTATION****Federal Transit Administration**

**Limitation on Claims Against Proposed Public Transportation Projects—TEXRail Extension Project and Richmond Highway Bus Rapid Transit (BRT) Project**

**AGENCY:** Federal Transit Administration (FTA), Department of Transportation (DOT).

**ACTION:** Notice.

**SUMMARY:** This notice announces final environmental actions taken by the Federal Transit Administration (FTA) regarding two projects: the TEXRail Extension Project in Tarrant County, Texas, and the Richmond Highway Bus Rapid Transit (BRT) Project in Fairfax County, Virginia. The purpose of this notice is to announce publicly the environmental decisions by FTA on the subject projects and to activate the limitation on any claims that may challenge these final environmental actions.

**DATES:** A claim seeking judicial review of FTA actions announced herein for the listed public transportation projects will be barred unless the claim is filed on or before July 5, 2022.

**FOR FURTHER INFORMATION CONTACT:** Kathryn Loster, Assistant Chief Counsel, Office of Chief Counsel, (312) 353-3869 or Saadat Khan, Environmental Protection Specialist, Office of Environmental Programs, (202) 366-9647. FTA is located at 1200 New Jersey

Avenue SE, Washington, DC 20590. Office hours are from 9:00 a.m. to 5:00 p.m., Monday through Friday, except Federal holidays.

**SUPPLEMENTARY INFORMATION:** Notice is hereby given that FTA has taken final agency actions subject to 23 U.S.C. 139(l) by issuing certain approvals for the public transportation projects listed below. The actions on the projects, as well as the laws under which such actions were taken, are described in the documentation issued in connection with the projects to comply with the National Environmental Policy Act (NEPA) and in other documents in the FTA environmental project files for the projects. Interested parties may contact either the project sponsor or the relevant FTA Regional Office for more information. Contact information for FTA's Regional Offices may be found at <https://www.transit.dot.gov>.

This notice applies to all FTA decisions on the listed projects as of the issuance date of this notice and all laws under which such actions were taken, including, but not limited to, NEPA (42 U.S.C. 4321-4375), Section 4(f) requirements (23 U.S.C. 138, 49 U.S.C. 303), Section 106 of the National Historic Preservation Act (54 U.S.C. 306108), Endangered Species Act (16 U.S.C. 1531), Clean Water Act (33 U.S.C. 1251), the Uniform Relocation and Real Property Acquisition Policies Act (42 U.S.C. 4601), and the Clean Air Act (42 U.S.C. 7401-7671q). This notice does not, however, alter or extend the limitation period for challenges of project decisions subject to previous notices published in the **Federal Register**. The projects and actions that are the subject of this notice follow:

1. *Project name and location:* TEXRail Extension Project, City of Fort Worth, Tarrant County, Texas. *Project Sponsor:* Trinity Metro, City of Fort Worth, Texas. *Project description:* The Project extends TEXRail commuter rail service approximately 2.1 miles south from the Fort Worth Texas & Pacific (T&P) Station to the Near Southside Station in the Fort Worth Medical District. The new station will be located behind Baylor Scott & White All Saints Medical Center, adjacent to the Mistletoe Heights neighborhood. The Project will utilize the Union Pacific Railroad right-of-way (ROW) traveling west from the Fort Worth T&P Station to a connection with the Fort Worth & Western Railroad (FWWR), where it then turns south to transition onto its own alignment running adjacent to the FWWR freight track, generally in the FWWR ROW. *Final agency action:* Section 106 Amended Memorandum of Agreement,

dated December 17, 2021; TEXRail Extension Project Finding of No Significant Impact (FONSI), dated December 17, 2021. *Supporting documentation:* TEXRail Extension Project Environmental Assessment (EA), dated October 31, 2021. The EA, FONSI and associated documents can be viewed and downloaded from: <https://ridetrinitymetro.org/textrail-extension/>.

2. *Project name and location:* Richmond Highway Bus Rapid Transit (BRT) Project, Fairfax County, Virginia. *Project Sponsor:* Fairfax County Department of Transportation, Fairfax, Virginia. *Project description:* The Richmond Highway BRT Project is a 7.4-mile fixed guideway BRT project on the Richmond Highway corridor from the Huntington Metrorail Station to Ft. Belvoir. The Project includes the construction of new BRT-dedicated median lanes, nine BRT stations, roadway widening, streetscape improvements, and construction of sidewalks and bicycle facilities along the Richmond Highway (or Route 1) predominantly within the existing transportation right-of-way in Fairfax County, VA. *Final agency actions:* Section 4(f) *de minimis* impact determination, dated January 7, 2022; Section 106 No Adverse Effect determination, dated January 15, 2021 with State Historic Preservation Officer (SHPO) concurrence on February 17, 2021; and Determination of the applicability of a categorical exclusion pursuant to 23 CFR 771.118(d) dated January 7, 2022. *Supporting documentation:* Documented Categorical Exclusion (CE) checklist and supporting materials dated January 4, 2022. The CE checklist and associated documents can be viewed and downloaded from: <https://www.fairfaxcounty.gov/transportation/richmond-hwy-brt>.

*Authority:* 23 U.S.C. 139(l)(1).

**Mark A. Ferroni,**

*Deputy Associate Administrator for Planning and Environment.*

[FR Doc. 2022-02175 Filed 2-2-22; 8:45 am]

**BILLING CODE 4910-57-P**

## DEPARTMENT OF TRANSPORTATION

### Great Lakes St. Lawrence Seaway Development Corporation

### Great Lakes St. Lawrence Seaway Development Corporation Advisory Board—Notice of Public Meetings

**AGENCY:** Great Lakes St. Lawrence Seaway Development Corporation (GLS); USDOT.

**ACTION:** Notice of public meetings.

**SUMMARY:** This notice announces the public meetings via conference call of the Great Lakes St. Lawrence Seaway Development Corporation Advisory Board.

**DATES:** The public meetings will be held on (all times Eastern):

- Tuesday, March 1, 2022 from 2 p.m.–4 p.m. EDT

- Requests to attend the meeting must be received by February 22, 2022.

- Requests for accommodations to a disability must be received by February 22, 2022.

- If you wish to speak during the meeting, you must submit a written copy of your remarks to GLS by February 22, 2022.

- Requests to submit written materials to be reviewed during the meeting must be received no later than February 22, 2022.

- Tuesday, May 24, 2022 from 20 p.m.–40 p.m. EDT (Massena, NY)

- Requests to attend the meeting must be received by May 17, 2022.

- Requests for accommodations to a disability must be received by May 17, 2022.

- If you wish to speak during the meeting, you must submit a written copy of your remarks to GLS by May 17, 2022.

- Requests to submit written materials to be reviewed during the meeting must be received no later than May 17, 2022.

- Tuesday, September 6, 2022 from 2 p.m.–4 p.m. EDT

- Requests to attend the meeting must be received by August 30, 2022.

- Requests for accommodations to a disability must be received by August 30, 2022.

- If you wish to speak during the meeting, you must submit a written copy of your remarks to GLS by August 30, 2022.

- Requests to submit written materials to be reviewed during the meeting must be received no later than August 30, 2022.

- Tuesday, November 15, 2022 from 2 p.m.–4 p.m. EDT (Washington, DC)

- Requests to attend the meeting must be received by November 8, 2022.

- Requests for accommodations to a disability must be received by November 8, 2022.

- If you wish to speak during the meeting, you must submit a written copy of your remarks to GLS by November 8, 2022.

- Requests to submit written materials to be reviewed during the meeting must be received no later than November 8, 2022.

**ADDRESSES:** The meetings will be held via conference call at the GLS's Operations location, 180 Andrews Street, Massena, NY 13662.

**FOR FURTHER INFORMATION CONTACT:** Martin Welles, Executive Officer, Great Lakes St. Lawrence Seaway Development Corporation, 1200 New Jersey Avenue SE, Washington, DC 20590; 315-764-3231. (Is this your number?)

**SUPPLEMENTARY INFORMATION:** Pursuant to Section 10(a)(2) of the Federal Advisory Committee Act (Public Law 92-463; 5 U.S.C. App. 2), notice is hereby given of meetings of the GLS Advisory Board. The agenda for each meeting is the same and will be as follows:

Tuesday, March 1, 2022 from 2 p.m.–4 p.m. EDT

Tuesday, May 24, 2022 from 2 p.m.–4 p.m. EDT

Tuesday, September 6, 2022 from 2 p.m.–4 p.m. EDT

Tuesday, November 15, 2022 from 2 p.m.–4 p.m. EDT

1. Opening Remarks
2. Consideration of Minutes of Past Meeting
3. Quarterly Report
4. Old and New Business
5. Closing Discussion
6. Adjournment

#### *Public Participation*

Attendance at the meeting is open to the interested public. With the approval of the Administrator, members of the public may present oral statements at the meeting. Persons wishing further information should contact the person listed under the heading, **FOR FURTHER INFORMATION CONTACT**. There will be three (3) minutes allotted for oral comments from members of the public joining the meeting. To accommodate as many speakers as possible, the time for each commenter may be limited. Individuals wishing to reserve speaking time during the meeting must submit a request at the time of registration, as well as the name, address, and organizational affiliation of the proposed speaker. If the number of registrants requesting to make statements is greater than can be reasonably accommodated during the meeting, the GLS conduct a lottery to determine the speakers. Speakers are requested to submit a written copy of their prepared remarks for inclusion in the meeting records and for circulation to GLS Advisory Board members. All

prepared remarks submitted will be accepted and considered as part of the meeting's record. Any member of the public may submit a written statement after the meeting deadline, and it will be presented to the committee.

The U.S. Department of Transportation is committed to providing equal access to this meeting for all participants. If you need alternative formats or services because of a disability, such as sign language, interpretation, or other ancillary aids, please contact the person listed in the **FOR FURTHER INFORMATION CONTACT** section. Any member of the public may present a written statement to the Advisory Board at any time.

Issued at Washington, DC.

**Carrie Lavigne,**

(Approving Official), Chief Counsel, Great Lakes St. Lawrence Seaway Development Corporation.

[FR Doc. 2022-02290 Filed 2-2-22; 8:45 am]

BILLING CODE 4910-61-P

## DEPARTMENT OF THE TREASURY

### Office of the Comptroller of the Currency

#### Agency Information Collection Requirements; Information Collection Renewal; Submission for OMB Review; OCC Guidelines Establishing Standards for Recovery Planning by Certain Large Insured National Banks, Large Insured Federal Savings Associations, and Large Insured Federal Branches

**AGENCY:** Office of the Comptroller of the Currency (OCC), Treasury.

**ACTION:** Notice and request for comment.

**SUMMARY:** The OCC, as part of its continuing effort to reduce paperwork and respondent burden, invites the general public and other Federal agencies to take this opportunity to comment on a continuing information collection as required by the Paperwork Reduction Act of 1995 (PRA). In accordance with the requirements of the PRA, the OCC may not conduct or sponsor, and the respondent is not required to respond to, an information collection unless it displays a currently valid Office of Management and Budget (OMB) control number. The OCC is soliciting comment concerning the renewal of its information collection titled, "OCC Guidelines Establishing Standards for Recovery Planning by Certain Large Insured National Banks, Insured Federal Savings Associations, and Insured Federal Branches." The

OCC also is giving notice that it has sent the collection to OMB for review.

**DATES:** You should submit written comments by March 7, 2022.

**ADDRESSES:** Commenters are encouraged to submit comments by email, if possible. You may submit comments by any of the following methods:

- *Email:* [prainfo@occ.treas.gov](mailto:prainfo@occ.treas.gov).

- *Mail:* Chief Counsel's Office,

Attention: Comment Processing, 1557-0333, Office of the Comptroller of the Currency, 400 7th Street SW, Suite 3E-218, Washington, DC 20219.

- *Hand Delivery/Courier:* 400 7th Street SW, Suite 3E-218, Washington, DC 20219.

- *Fax:* (571) 465-4326.

Instructions: You must include "OCC" as the agency name and "1557-0333" in your comment. In general, the OCC will publish comments on [www.reginfo.gov](http://www.reginfo.gov) without change, including any business or personal information provided, such as name and address information, email addresses, or phone numbers. Comments received, including attachments and other supporting materials, are part of the public record and subject to public disclosure. Do not include any information in your comment or supporting materials that you consider confidential or inappropriate for public disclosure.

Written comments and recommendations for the proposed information collection should also be sent within 30 days of publication of this notice to [www.reginfo.gov/public/do/PRAMain](http://www.reginfo.gov/public/do/PRAMain). Find this particular information collection by selecting "Currently under 30-day Review—Open for Public Comments" or by using the search function. On October 29, 2021, the OCC published a 60-day notice for this information collection, 86 FR 60105. You may review comments and other related materials that pertain to this information collection following the close of the 30-day comment period for this notice by the method set forth in the next bullet.

- *Viewing Comments Electronically:* Go to [www.reginfo.gov](http://www.reginfo.gov). Hover over the "Information Collection Review" tab and click on "Information Collection Review" drop-down menu. From the "Currently under Review" drop-down menu, select "Department of Treasury" and then click "submit." This information collection can be located by searching by OMB control number "1557-0333" or "OCC Guidelines Establishing Standards for Recovery Planning by Certain Large Insured National Banks, Insured Federal Savings Associations, and Insured Federal

Branches." Upon finding the appropriate information collection, click on the related "ICR Reference Number." On the next screen, select "View Supporting Statement and Other Documents" and then click on the link to any comment listed at the bottom of the screen.

- For assistance in navigating [www.reginfo.gov](http://www.reginfo.gov), please contact the Regulatory Information Service Center at (202) 482-7340.

#### FOR FURTHER INFORMATION CONTACT:

Shaquita Merritt, OCC Clearance Officer, (202) 649-5490, Chief Counsel's Office, Office of the Comptroller of the Currency, 400 7th Street SW, Suite 3E-218, Washington, DC 20219.

**SUPPLEMENTARY INFORMATION:** Under the PRA (44 U.S.C. 3501-3520), Federal agencies must obtain approval from the Office of Management and Budget (OMB) for each collection of information that they conduct or sponsor. "Collection of information" is defined in 44 U.S.C. 3502(3) and 5 CFR 1320.3(c) to include agency requests or requirements that members of the public submit reports, keep records, or provide information to a third party. The OCC asks that OMB extend its approval of this collection.

*Title:* OCC Guidelines Establishing Standards for Recovery Planning by Certain Large Insured National Banks, Insured Federal Savings Associations, and Insured Federal Branches.

*OMB Control No.:* 1557-0333.

*Abstract:* In 2015, the OCC issued guidelines applicable to each insured national bank, insured Federal savings association, and insured Federal branch of a foreign bank (together, banks) with average total consolidated assets equal to or greater than \$50 billion (covered banks). The guidelines stated that each covered bank should develop and maintain a recovery plan that is appropriate for its individual size, risk profile, activities, and complexity, including the complexity of its organizational and legal entity structure, in order to be able to respond quickly to and recover from the financial effects of severe stress. The guidelines established standards for this recovery planning.

The OCC issued a final rule in 2018 that increased the average total consolidated assets threshold for applying the recovery planning guidelines to a bank from \$50 billion to \$250 billion and decreased from 18 months to 12 months the time within which a bank should comply with the recovery planning guidelines after the

bank first becomes subject to the guidelines.<sup>1</sup>

**Overview of covered bank.** A recovery plan should describe the covered bank's overall organizational and legal entity structure, including its material entities, critical operations, core business lines, and core management information systems. The plan should describe interconnections and interdependencies (1) across business lines within the covered bank; (2) with affiliates in a bank holding company structure; (3) between a covered bank and its foreign subsidiaries and (4) with critical third parties.

**Triggers.** A covered bank's recovery plan should identify triggers that appropriately reflect the bank's particular vulnerabilities.

**Options for recovery.** A recovery plan should identify a wide range of credible options that a covered bank could undertake to restore financial strength and viability, thereby allowing the bank to continue to operate as a going concern and to avoid liquidation or resolution. A recovery plan should explain how the covered bank would carry out each option and describe the timing required for carrying out each option. The recovery plan should specifically identify the recovery options that require approval.

**Impact assessments.** For each recovery option, a covered bank should assess and describe how the option would affect the covered bank. This impact assessment and description should specify the procedures the covered bank would use to maintain the financial strength and viability of its material entities, critical operations, and core business lines for each recovery option. For each option, the recovery plan's impact assessment should address the following: (1) The effect on the covered bank's capital, liquidity, funding, and profitability; (2) the effect on the covered bank's material entities, critical operations, and core business lines, including reputational impact; and (3) any legal or market impediment or regulatory requirement that must be addressed or satisfied in order to implement the option.

**Escalation procedures.** A recovery plan should clearly outline the process for escalating decision-making to the covered bank's senior management, board of directors (board), or appropriate board committee in response to the breach of any trigger. The recovery plan should also identify the departments and persons responsible for executing the decisions

of senior management, the board, or an appropriate board committee.

**Management reports.** A recovery plan should require reports that provide senior management, the board, or an appropriate board committee with sufficient data and information to make timely decisions regarding the appropriate actions necessary to respond to the breach of a trigger.

**Communication procedures.** A recovery plan should provide that the covered bank will notify the OCC of any significant breach of a trigger and any action taken or to be taken in response to such breach and should explain the process for deciding when a breach of a trigger is significant. A recovery plan also should address when and how the covered bank will notify persons within the organization and other external parties of its action under the recovery plan. The recovery plan should specifically identify how the covered bank will obtain required approvals.

**Other information.** A recovery plan should include any other information that the OCC communicates in writing directly to the covered bank regarding the covered bank's recovery plan.

A covered bank should (1) integrate its recovery plan into its risk governance functions and (2) align its recovery plan with its other plans, such as its strategic, operational (including business continuity), contingency, capital (including stress testing), liquidity, and resolution planning. The covered bank's recovery plan also should be specific to that covered bank and coordinated with any recovery and resolution planning efforts by the bank's holding company.

A covered bank's recovery plan should address the responsibilities of the bank's management and board with respect to the plan. Specifically, management should review the recovery plan at least annually and in response to a material event. It should revise the plan as necessary to reflect material changes in the covered bank's size, risk profile, activities, and complexity, as well as changes in external threats. This review should evaluate the organizational structure and its effectiveness in facilitating a recovery. The board is responsible for overseeing the covered bank's recovery planning process. The board of a covered bank or an appropriate board committee should review and approve the recovery plan at least annually, and as needed to address significant changes made by management.

The OCC believes that a large, complex institution should undertake recovery planning in order to be able to respond quickly to and recover from the financial effects of severe stress on the

institution. The process of developing and maintaining a recovery plan also should cause a covered bank's management and its board to enhance their focus on risk governance with a view toward lessening the negative impact of future events. OCC examiners will assess the appropriateness and adequacy of the covered bank's ongoing recovery planning process as part of the agency's regular supervisory activities.

**Type of Review:** Extension, without change, of a currently approved collection.

**Affected Public:** Businesses or other for-profit; individuals.

**Total Number of Respondents:** 8.

**Total Burden per Respondent:** 7,543 hours.

**Total Burden for Collection:** 60,344 hours.

On October 29, 2021, the OCC published a 60-day notice for this information collection, 86 FR 60105. No comments were received. Comments continue to be solicited on:

(a) Whether the collection of information is necessary for the proper performance of the functions of the agency, including whether the information has practical utility;

(b) The accuracy of the agency's estimate of the burden of the collection of information;

(c) Ways to enhance the quality, utility, and clarity of the information to be collected;

(d) Ways to minimize the burden of the collection on respondents, including through the use of automated collection techniques or other forms of information technology; and

(e) Estimates of capital or start-up costs and costs of operation, maintenance, and purchase of services to provide information.

**Theodore J. Dowd,**

*Deputy Chief Counsel, Office of the Comptroller of the Currency.*

[FR Doc. 2022-02301 Filed 2-2-22; 8:45 am]

**BILLING CODE 4810-33-P**

## DEPARTMENT OF THE TREASURY

### Office of Foreign Assets Control

#### Notice of OFAC Sanctions Actions

**AGENCY:** Office of Foreign Assets Control, Treasury.

**ACTION:** Notice.

**SUMMARY:** The U.S. Department of the Treasury's Office of Foreign Assets Control (OFAC) is publishing the names of one or more persons that have been placed on OFAC's Specially Designated Nationals and Blocked Persons List

<sup>1</sup> 83 FR 66604 (December 27, 2018).

(SDN List) based on OFAC's determination that one or more applicable legal criteria were satisfied. All property and interests in property subject to U.S. jurisdiction of these persons are blocked, and U.S. persons are generally prohibited from engaging in transactions with them.

**DATES:** See **SUPPLEMENTARY INFORMATION** section for applicable date(s).

**FOR FURTHER INFORMATION CONTACT:** OFAC: Andrea Gacki, Director, tel.: 202-622-2490; Associate Director for Global Targeting, tel.: 202-622-2420; Assistant Director for Licensing, tel.: 202-622-2480; Assistant Director for Regulatory Affairs, tel.: 202-622-4855; or Assistant Director for Sanctions Compliance & Evaluation, tel.: 202-622-2490.

**SUPPLEMENTARY INFORMATION:**

**Electronic Availability**

The SDN List and additional information concerning OFAC sanctions programs are available on OFAC's website (<https://www.treasury.gov/ofac>).

**Notice of OFAC Actions**

On January 31, 2022, OFAC determined that the property and interests in property subject to U.S. jurisdiction of the following persons are blocked under the relevant sanctions authority listed below.

**Individuals**

1. OO, Thida (a.k.a. OO, Daw Thida; a.k.a. OO, Thi Da), Burma; DOB 27 Nov 1964; POB Rangoon, Burma; nationality Burma; citizen Burma; Gender Female; Passport DM003921 (Burma) issued 02 Aug 2017 expires 01 Aug 2027; Union Attorney General (individual) [BURMA-EO14014].

Designated pursuant to section 1(a)(iii)(B) of Executive Order 14014 of February 10, 2021, "Blocking Property With Respect To The Situation In Burma" ("E.O. 14014"), 86 FR 9429, for being a foreign person who is or has been a leader or official of the Government of Burma on or after February 2, 2021.

2. OO, Tin (a.k.a. OO, U Tin), No. 22, Thanlwin Street, Pyinyawady Condominium, No. 5 Quarter, Yankin Township, Rangoon, Burma; DOB 24 Nov 1952; nationality Burma; citizen Burma; Gender Male; National ID No. 5KALATANAINING127084 (Burma); Chairman of Anti-Corruption Commission (individual) [BURMA-EO14014].

Designated pursuant to section 1(a)(iii)(B) of E.O. 14014 for being a foreign person who is or has been a leader or official of the Government of Burma on or after February 2, 2021.

3. OO, Tun Tun (a.k.a. OO, Htun Htun; a.k.a. OO, U Htun Htun; a.k.a. OO, U Tun Tun), Naypyitaw, Burma; DOB 28 Jul 1956; nationality Burma; citizen Burma; Gender Male; Chief Justice of Union Supreme Court (individual) [BURMA-EO14014].

Designated pursuant to section 1(a)(iii)(B) of E.O. 14014 for being a foreign person who is or has been a leader or official of the Government of Burma on or after February 2, 2021.

4. TAY ZA, Htoo Htet (a.k.a. TAYZA, Htoo Htet), Burma; DOB 24 Jan 1993; alt. DOB 24 Jan 1994; citizen Burma; Gender Male (individual) [BURMA-EO14014] (Linked To: ZA, Tay).

Designated pursuant to section 1(a)(v) of E.O. 14014 for being a spouse or adult child of TAY ZA, a person whose property and interests in property are blocked pursuant to E.O. 14014.

5. TAY ZA, Pye Phyo (a.k.a. TAY ZA, Pyae Phyo; a.k.a. TAYZA, Pye Phyo), Burma; DOB 29 Jan 1987; POB Burma; nationality Burma; Gender Male (individual) [BURMA-EO14014] (Linked To: ZA, Tay).

Designated pursuant to section 1(a)(v) of E.O. 14014 for being a spouse or adult child of TAY ZA, a person whose property and interests in property are blocked pursuant to E.O. 14014.

6. THAUNG, Jonathan Myo Kyaw (a.k.a. TAUNG, Jonathan Kwang; a.k.a. THAUNG, Jonathan Kwang; a.k.a. THAUNG, Jonathan Kyaw; a.k.a. "MYO, Jonathan"), Burma; DOB 29 Dec 1981; nationality Burma; Gender Male (individual) [BURMA-EO14014] (Linked To: MYANMA ECONOMIC HOLDINGS PUBLIC COMPANY LIMITED).

Designated pursuant to section 1(a)(vi) of E.O. 14014 for having materially assisted, sponsored, or provided financial, material, or technological support for, or goods or services to or in support of MYANMA ECONOMIC HOLDINGS PUBLIC COMPANY LIMITED (MEHL), a person whose property and interests in property are blocked pursuant to E.O. 14014.

7. ZA, Tay, Singapore; Burma; DOB 18 Jul 1964; alt. DOB 18 Jul 1967; POB Burma; citizen Burma; Gender Male; Passport 306869 (Burma); National ID No. MYGN 006415 (Burma) (individual) [BURMA-EO14014].

Designated pursuant to section 1(a)(i) of E.O. 14014 for operating in the defense sector of the Burmese economy or any other sector of the Burmese economy as may be determined by the Secretary of the Treasury, in consultation with the Secretary of State.

**Entity**

1. DIRECTORATE OF PROCUREMENT OF THE COMMANDER-IN-CHIEF OF DEFENSE SERVICES ARMY (a.k.a. DIRECTORATE OF PROCUREMENT, OFFICE OF THE COMMANDER-IN-CHIEF ARMY, THE REPUBLIC OF THE UNION OF MYANMAR; a.k.a. MYANMAR DIRECTORATE OF PROCUREMENT; a.k.a. "DIRECTORATE OF DEFENSE PROCUREMENT"; a.k.a. "DIRECTORATE OF PROCUREMENT"), Nay Pyi Taw City, Burma; Target Type Government Entity [BURMA-EO14014].

Designated pursuant to section 1(a)(i) of E.O. 14014 for operating in the defense sector of the Burmese economy or any other sector of the Burmese economy as may be determined by the Secretary of the Treasury, in consultation with the Secretary of State.

2. KT SERVICES & LOGISTICS KTSL COMPANY LIMITED (a.k.a. KT SERVICES & LOGISTICS CO., LTD; a.k.a. KT SERVICES

AND LOGISTICS CO., LTD; a.k.a. KT SERVICES AND LOGISTICS COMPANY LIMITED; a.k.a. KT SERVICES AND LOGISTICS KTSL COMPANY LIMITED), Pyay Road, A4/A5 Kamayut Township, Rangoon 11201, Burma; Registration Country Burma; Organization Established Date 18 Feb 2014; Registration Number 108301848 (Burma) [BURMA-EO14014] (Linked To: MYANMA ECONOMIC HOLDINGS PUBLIC COMPANY LIMITED).

Designated pursuant to section 1(a)(vi) of E.O. 14014 for having materially assisted, sponsored, or provided financial, material, or technological support for, or goods or services to or in support of MEHL, a person whose property and interests in property are blocked pursuant to E.O. 14014.

*Authority:* E.O. 14014, 86 FR 9429.

*Dated:* January 31, 2022.

**Andrea M. Gacki,**

*Director, Office of Foreign Assets Control, U.S. Department of the Treasury.*

[FR Doc. 2022-02275 Filed 2-2-22; 8:45 am]

**BILLING CODE 4810-AL-P**

**DEPARTMENT OF THE TREASURY**

**Office of Foreign Assets Control**

**Notice of OFAC Sanctions Actions**

**AGENCY:** Office of Foreign Assets Control, Treasury.

**ACTION:** Notice.

**SUMMARY:** The U.S. Department of the Treasury's Office of Foreign Assets Control (OFAC) is publishing the name of one vessel identified as blocked property that has been removed from OFAC's Specially Designated Nationals and Blocked Persons List (SDN List). Property and interests relating to the vessel are no longer blocked, and U.S. persons are no longer generally prohibited from engaging in transactions relating to the vessel.

**DATES:** See **SUPPLEMENTARY INFORMATION** section for applicable date(s).

**FOR FURTHER INFORMATION CONTACT:** OFAC: Andrea Gacki, Director, tel.: 202-622-2480; Associate Director for Global Targeting, tel.: 202-622-2420; Assistant Director for Licensing, tel.: 202-622-2480; Assistant Director for Regulatory Affairs, tel.: 202-622-4855; or the Assistant Director for Sanctions Compliance & Evaluation, tel.: 202-622-2490.

**SUPPLEMENTARY INFORMATION:**

**Electronic Availability**

The SDN List and additional information concerning OFAC sanctions programs are available on OFAC's website ([www.treasury.gov/ofac](http://www.treasury.gov/ofac)).

**Notice of OFAC Actions**

On August 13, 2021, OFAC identified the following vessel as property in which a blocked person has an interest pursuant to Executive Order 13224 of September 23, 2001, "Blocking Property and Prohibiting Transactions With Persons Who Commit, Threaten to Commit, or Support Terrorism," as amended by Executive Order 13886 of September 9, 2019, "Modernizing Sanctions to Combat Terrorism." On January 31, 2022, OFAC determined that the property and interests in property subject to U.S. jurisdiction of the following vessel are no longer blocked, and the vessel has been removed from the SDN List.

**Vessel:**

1. OMAN PRIDE Crude Oil Tanker; Additional Sanctions Information—Subject to Secondary Sanctions; Vessel Registration Identification IMO 9153525 (vessel) [SDGT] (Linked To: BRAVERY MARITIME CORPORATION).

Dated: January 31, 2022.

**Andrea M. Gacki,**

*Director, Office of Foreign Assets Control,  
U.S. Department of the Treasury.*

[FR Doc. 2022-02304 Filed 2-2-22; 8:45 am]

**BILLING CODE 4810-AL-P**

**DEPARTMENT OF THE TREASURY****Office of Foreign Assets Control****Notice of OFAC Sanctions Actions**

**AGENCY:** Office of Foreign Assets Control, Treasury.

**ACTION:** Notice.

**SUMMARY:** The U.S. Department of the Treasury's Office of Foreign Assets Control (OFAC) is publishing the names of one or more persons that have been placed on OFAC's Specially Designated Nationals and Blocked Persons List (SDN List) based on OFAC's determination that one or more applicable legal criteria were satisfied. All property and interests in property subject to U.S. jurisdiction of these persons are blocked, and U.S. persons are generally prohibited from engaging in transactions with them.

**DATES:** See **SUPPLEMENTARY INFORMATION** section for effective date(s).

**FOR FURTHER INFORMATION CONTACT:**

OFAC: Andrea Gacki, Director, tel.: 202-622-2490; Associate Director for Global Targeting, tel.: 202-622-2420; Assistant Director for Licensing, tel.: 202-622-2480; Assistant Director for Regulatory Affairs, tel.: 202-622-4855; or Assistant Director for Sanctions Compliance & Evaluation, tel.: 202-622-2490.

**SUPPLEMENTARY INFORMATION:****Electronic Availability**

The SDN List and additional information concerning OFAC sanctions programs are available on OFAC's website (<https://www.treasury.gov/ofac>).

**Notice of OFAC Action(s)**

On January 12, 2020, OFAC determined that the property and interests in property subject to U.S. jurisdiction of the following persons are blocked under the relevant sanctions authority listed below.

**BILLING CODE 4810-AL-P**

**Individuals**



1. CHOE, Myong Hyon (a.k.a. CH'OE, Myo'ng-hyo'n), Vladivostok, Russia; DOB 20 Jan 1966; nationality Korea, North; Gender Male; Secondary sanctions risk: North Korea Sanctions Regulations, sections 510.201 and 510.210; Transactions Prohibited For Persons Owned or Controlled By U.S. Financial Institutions: North Korea Sanctions Regulations section 510.214; Passport 836210034 (Korea, North) issued 26 Apr 2016 expires 26 Apr 2021 (individual) [NPWMD] (Linked To: SECOND ACADEMY OF NATURAL SCIENCES).

Designated pursuant to section 1(a)(iii) of Executive Order 13382 of June 28, 2005, "Blocking Property of Weapons of Mass Destruction Proliferators and Their Supporters," 70 FR 38567, 3 CFR, 2006 Comp., p. 170 (E.O. 13382), for having provided, or attempted to provide, goods or services in support of, SECOND ACADEMY OF NATURAL SCIENCES.

2. KANG, Chol Hak (Korean: 강철학) (a.k.a. KANG, Ch'o'l-hak), Shenyang, China; DOB 06 Sep 1962; nationality Korea, North; Gender Male; Secondary sanctions risk: North Korea Sanctions Regulations, sections 510.201 and 510.210; Transactions Prohibited For Persons Owned or Controlled By U.S. Financial Institutions: North Korea Sanctions Regulations section 510.214 (individual) [NPWMD] (Linked To: SECOND ACADEMY OF NATURAL SCIENCES).

Designated pursuant to section 1(a)(iii) of E.O. 13382, for having provided, or attempted to provide, goods or services in support of, SECOND ACADEMY OF NATURAL SCIENCES.

3. KIM, Song Hun (a.k.a. KIM, So'ng-hun), Shenyang, China; DOB 10 Apr 1978; nationality Korea, North; Gender Male; Secondary sanctions risk: North Korea Sanctions Regulations, sections 510.201 and 510.210; Transactions Prohibited For Persons Owned or Controlled By U.S. Financial Institutions: North Korea Sanctions Regulations section 510.214; Passport 745235023 (Korea, North) (individual) [NPWMD] (Linked To: SECOND ACADEMY OF NATURAL SCIENCES).

Designated pursuant to section 1(a)(iii) of E.O. 13382, for having provided, or attempted to provide, goods or services in support of, SECOND ACADEMY OF NATURAL SCIENCES.

4. PYON, Kwang Chol (a.k.a. PYO'N, Kwang-ch'o'l), Dalian, China; DOB 16 Sep 1964; nationality Korea, North; Gender Male; Secondary sanctions risk: North Korea Sanctions Regulations, sections 510.201 and 510.210; Transactions Prohibited For Persons Owned or Controlled By U.S. Financial Institutions: North Korea Sanctions Regulations section 510.214 (individual) [NPWMD] (Linked To: SECOND ACADEMY OF NATURAL SCIENCES).

Designated pursuant to section 1(a)(iii) of E.O. 13382, for having provided, or attempted to provide, goods or services in support of, SECOND ACADEMY OF NATURAL SCIENCES.

5. SIM, Kwang Sok (a.k.a. SIM, Kwang-so'k), Dalian, China; DOB 16 Sep 1971; nationality Korea, North; Gender Male; Secondary sanctions risk: North Korea Sanctions Regulations, sections 510.201 and 510.210; Transactions Prohibited For Persons Owned or Controlled By U.S. Financial Institutions: North Korea Sanctions Regulations section 510.214; Passport 745120331 (Korea, North) issued 19 Mar 2015 expires 19 Mar 2020 (individual) [NPWMD] (Linked To: SECOND ACADEMY OF NATURAL SCIENCES).

Designated pursuant to section 1(a)(iii) of E.O. 13382, for having provided, or attempted to provide, goods or services in support of, SECOND ACADEMY OF NATURAL SCIENCES.

*Authority:* E.O. 13382, 70 FR 38567, 3 CFR, 2005 Comp., p. 170.

Dated: January 12, 2022.

**Andrea M. Gacki,**

*Director, Office of Foreign Assets Control U.S. Department of the Treasury.*

[FR Doc. 2022-02273 Filed 2-2-22; 8:45 am]

**BILLING CODE 4810-AL-C**

## U.S.-CHINA ECONOMIC AND SECURITY REVIEW COMMISSION

### Notice of Open Public Hearing

**AGENCY:** U.S.-China Economic and Security Review Commission.

**ACTION:** Notice of open public hearing.

**SUMMARY:** Notice is hereby given of the following hearing of the U.S.-China Economic and Security Review Commission. The Commission is mandated by Congress to investigate, assess, and report to Congress annually on "the national security implications of the economic relationship between the United States and the People's Republic of China." Pursuant to this mandate, the Commission will hold a public hearing in Washington, DC on February 17, 2022 on "China's Cyber Capabilities: Warfare, Espionage, and Implications for the United States."

**DATES:** The hearing is scheduled for Thursday, February 17, 2022, at 9:00 a.m.

**ADDRESSES:** This hearing will be held with panelists and Commissioners participating in-person or online via

videoconference. Members of the audience will be able to view a live webcast via the Commission's website at [www.uscc.gov](http://www.uscc.gov). Also, please check the Commission's website for possible changes to the hearing schedule. *Reservations are not required to attend the hearing.*

**FOR FURTHER INFORMATION CONTACT:** Any member of the public seeking further information concerning the hearing should contact Jameson Cunningham, 444 North Capitol Street NW, Suite 602, Washington, DC 20001; telephone: 202-624-1496, or via email at [jcunningham@uscc.gov](mailto:jcunningham@uscc.gov). *Reservations are not required to attend the hearing.*

**ADA Accessibility:** For questions about the accessibility of the event or to request an accommodation, please contact Jameson Cunningham via email at [jcunningham@uscc.gov](mailto:jcunningham@uscc.gov). Requests for an accommodation should be made as soon as possible, and at least five business days prior to the event.

#### SUPPLEMENTARY INFORMATION:

**Background:** This is the second public hearing the Commission will hold during its 2022 report cycle. The hearing will start with an assessment of China's perspective on cyberwarfare, focusing specifically on the People's Liberation Army (PLA)'s doctrine and capabilities in this domain. Subsequent panels will explore China's motivations and capabilities for cyberespionage as well as the implications of China's cyber activities for the United States.

The hearing will be co-chaired by Commissioners Carolyn Bartholomew and Alex Wong. Any interested party

may file a written statement by February 17, 2022, by transmitting to the contact above. A portion of the hearing will include a question and answer period between the Commissioners and the witnesses.

**Authority:** Congress created the U.S.-China Economic and Security Review Commission in 2000 in the National Defense Authorization Act (Pub. L. 106-398), as amended by Division P of the Consolidated Appropriations Resolution, 2003 (Pub. L. 108-7), as amended by Public Law 109-108 (November 22, 2005), as amended by Public Law 113-291 (December 19, 2014).

Dated: January 28, 2022.

**Daniel W. Peck,**

*Executive Director, U.S.-China Economic and Security Review Commission.*

[FR Doc. 2022-02309 Filed 2-2-22; 8:45 am]

**BILLING CODE 1137-00-P**

## DEPARTMENT OF VETERANS AFFAIRS

### Advisory Committee on the Readjustment of Veterans, Notice of Meeting

The Department of Veterans Affairs (VA) gives notice under the Federal Advisory Committee Act, 5 U.S.C., app. 2., that the Advisory Committee on the Readjustment of Veterans will meet virtually on February 8, 2022–February 10, 2022. The sessions will begin and end as follows:

Dates:	Times:
Tuesday, February 8, 2022 .....	1:00 p.m. to 5:00 p.m. Eastern Standard Time (EST).
Wednesday, February 9, 2022 .....	1:00 p.m. to 5:00 p.m. EST.

Dates:	Times:
Thursday, February 10, 2022 .....	1:00 p.m. to 5:00 p.m. EST.

Sessions are open to the public, except when the Committee is conducting tours of VA facilities, and participating in off-site events. Tours of VA facilities are closed to protect Veterans' privacy and personal information, in accordance with 5 U.S.C. Sec. 552b(c)(6).

Pursuant to 41 CFR 102-3.150, notice of this meeting is provided less than fifteen (15) calendar days prior to the date of the meeting as a resurgence in the COVID-19 pandemic has impacted availability of presenters, Committee Members, VA facility leadership, caused travel disruptions and altered scheduling dates. These exceptional circumstances were out of the control of the Agency and Committee but directly impacted the ability to definitively determine meeting dates and also meet the 15-day notice period. Accordingly, and upon a finding that exceptional circumstances exist that warrant providing notice less than 15 calendar days prior to the meeting of the Committee, the Advisory Committee Management Officer waives the notification requirements pursuant to 41 CFR 102-3.150(b).

The purpose of the Committee is to advise the VA regarding the provision by VA of benefits and services to assist Veterans in the readjustment to civilian life. In carrying out this duty, the Committee shall take into account the needs of Veterans who served in combat theaters of operation. The Committee assembles, reviews, and assesses information relating to the needs of Veterans readjusting to civilian life and the effectiveness of VA services in assisting Veterans in that readjustment.

The Committee, comprised of 13 subject matter experts, advises the Secretary, through the VA Readjustment Counseling Service, on the provision by VA of benefits and services to assist Veterans in the readjustment to civilian life. In carrying out this duty, the Committee assembles, reviews, and assesses information relating to the needs of Veterans readjusting to civilian life and the effectiveness of VA services in assisting Veterans in that readjustment, specifically taking into account the needs of Veterans who served in combat theaters of operation.

On February 8, 2022, the agenda will include a virtual site visit of the Jacksonville, NC Vet Center at 110A Branchwood Drive, Jacksonville, NC,

this field visit on February 8, 2022, from 1:00 p.m.–3:00 p.m. EST, is closed to the public in accordance with 5 U.S.C. 552b(c)(6). Exemption 6 permits the Committee to close a meeting that is likely to disclose information of a personal nature where disclosure would constitute a clearly unwarranted invasion of personal privacy, which will most likely be the case throughout this field visit. The remainder of the meeting will include a meeting with the Fayetteville North Carolina VA Medical Center leadership team, and an overview presentation of Readjustment Counseling Service Communications Office Outreach efforts from 3:00 p.m.–4:00 p.m. EST, and a period of open discussion amongst committee members following.

On February 9, 2022, the agenda will include a visit with the Readjustment Counseling team of the Jacksonville, NC Vet Center, this field visit on 2/9/2022 from 1:00 p.m.–2:00 p.m. EST is closed to the public in accordance with 5 U.S.C. 552b(c)(6). Exemption 6 permits the Committee to close a meeting that is likely to disclose information of a personal nature where disclosure would constitute a clearly unwarranted invasion of personal privacy, which will most likely be the case throughout this field visit. The remainder of the meeting will include a briefing from the VA National Center for Veterans Analysis and Statistics from 2:00 p.m.–3:00 p.m. EST, and an overview of the Veteran Experience Office CVEB program by the VA Veteran Experience Office from 3:00 p.m.–4:00 p.m. EST.

On February 10, 2022 the agenda will be solely focused on writing the committees 22nd annual report, which will be accomplished through breakout groups and open full committee discussion.

No time will be allotted for receiving oral comments from the public; however, the committee will accept written comments from interested parties on issues outlined in the meeting agenda or other issues regarding the readjustment of Veterans. Parties should contact Mr. Richard Barbato, via email at [VHARCSPanningPolicy@va.gov](mailto:VHARCSPanningPolicy@va.gov) or by mail at Department of Veterans Affairs, Readjustment Counseling Service (10RCS), 810 Vermont Avenue, Washington, DC 20420.

Any member of the public seeking additional information should contact Ms. Moravy at the email addressed noted above. For any members of the public that wish to attend the open portions of the virtual meeting, they may use the following WebEx link(s):

#### Tuesday, February 8, 2022

*Meeting link:* <https://veteransaffairs.webex.com/webappng/sites/veteransaffairs/meeting/download/329e176020c24084b21c86bb49ec7349?siteurl=veteransaffairs&MTID=mcc4a2194a8aaf46ea36fae44f0bec0d6>.

*Tap to join from a mobile device (attendees only):* +14043971596,, 27617207286## USA Toll Number.

*Join by phone:* 14043971596 USA Toll Number, Global call-in numbers | Toll-free calling restrictions.

*Join by phone for non-VA Staff:* 18335580712 USA Toll-free Number.

#### Wednesday, February 9, 2022

*Meeting link:* <https://veteransaffairs.webex.com/webappng/sites/veteransaffairs/meeting/download/8b6fbc6b57b24bb8950bd560285df151?siteurl=veteransaffairs&MTID=m9855adfff1a298e5e7dc697bc5a36611>.

*Tap to join from a mobile device (attendees only):* +14043971596,, 27638719703## USA Toll Number.

*Join by phone:* 14043971596 USA Toll Number.

#### Thursday, February 10, 2022

*Meeting link:* <https://veteransaffairs.webex.com/webappng/sites/veteransaffairs/meeting/download/cf35794c3adb43dd870a662db8c3ddd3?siteurl=veteransaffairs&MTID=m0b498c8be1968ec41d6924f5178b76e6>

*Tap to join from a mobile device (attendees only):* +14043971596,, 27623428576## USA Toll Number.

*Join by phone:* 14043971596 USA Toll Number, Global call-in numbers | Toll-free calling restrictions.

*Join by phone for non-VA Staff:* 18335580712 USA Toll-free Number.

Dated: January 28, 2022.

**Jelessa M. Burney,**  
Federal Advisory Committee Management Officer.

[FR Doc. 2022-02146 Filed 2-2-22; 8:45 am]

**BILLING CODE P**



# FEDERAL REGISTER

---

Vol. 87

Thursday,

No. 23

February 3, 2022

---

Part II

## Consumer Product Safety Commission

---

16 CFR Parts 1112 and 1261

Safety Standard for Clothing Storage Units; Proposed Rule

## CONSUMER PRODUCT SAFETY COMMISSION

### 16 CFR Parts 1112 and 1261

[Docket No. CPSC–2017–0044]

#### Safety Standard for Clothing Storage Units

**AGENCY:** Consumer Product Safety Commission.

**ACTION:** Notice of proposed rulemaking.

**SUMMARY:** The U.S. Consumer Product Safety Commission (Commission or CPSC) has determined preliminarily that there is an unreasonable risk of injury and death, particularly to children, associated with clothing storage units (CSUs) tipping over. To address this risk, the Commission proposes a rule addressing the stability of CSUs. Specifically, the proposed rule would require CSUs to be tested for stability, exceed minimum stability requirements, be marked and labeled with safety information, and bear a hang tag providing performance and technical data about the stability of the CSU. The Commission issues this proposed rule under the authority of the Consumer Product Safety Act (CPSA). The Commission requests comments about all aspects of this notice, including the risk of injury, the proposed requirements, alternatives to the proposed rule, and the economic impacts of the proposed rule and alternatives.

**DATES:** Submit comments by April 19, 2022.

**ADDRESSES:** Direct comments related to the Paperwork Reduction Act aspects of the proposed rule to the Office of Information and Regulatory Affairs, the Office of Management and Budget, Attn: CPSC Desk Officer, fax to: 202–395–6974, or email [oir\\_submission@omb.eop.gov](mailto:oir_submission@omb.eop.gov). Submit other comments, identified by Docket No. CPSC–2017–0044, by any of the following methods:

**Electronic Submissions:** Submit electronic comments to the Federal eRulemaking Portal at: <https://www.regulations.gov>. Follow the instructions for submitting comments. CPSC does not accept comments submitted by electronic mail (email), except through <https://www.regulations.gov>, and as described below. CPSC encourages you to submit electronic comments by using the Federal eRulemaking Portal, as described above.

**Mail/Hand Delivery/Courier Written Submissions:** Submit comments by mail/hand delivery/courier to: Division of the Secretariat, Consumer Product

Safety Commission 4330 East-West Highway, Bethesda, MD 20814; telephone: (301) 504–7479. Alternatively, as a temporary option during the COVID–19 pandemic, you can email such submissions to: [cpsc-os@cpsc.gov](mailto:cpsc-os@cpsc.gov).

**Instructions:** All submissions must include the agency name and docket number for this notice. CPSC may post all comments without change, including any personal identifiers, contact information, or other personal information provided, to: <https://www.regulations.gov>. Do not submit electronically: Confidential business information, trade secret information, or other sensitive or protected information that you do not want to be available to the public. If you wish to submit such information, please submit it according to the instructions for mail/hand delivery/courier written submissions.

**Docket:** To read background documents or comments regarding this proposed rulemaking, go to: <https://www.regulations.gov>, insert docket number CPSC–2017–0044 in the “Search” box, and follow the prompts.

#### FOR FURTHER INFORMATION CONTACT:

Kristen Talcott, Project Manager, U.S. Consumer Product Safety Commission, 5 Research Place, Rockville, MD 20852; telephone (301) 987–2311; email: [KTalcott@cpsc.gov](mailto:KTalcott@cpsc.gov).

#### SUPPLEMENTARY INFORMATION:

##### I. Background

CSUs are freestanding furniture items, typically used for storing clothes. Examples of CSUs include chests, bureaus, dressers, chests of drawers, drawer chests, door chests, chifforobes, armoires, and wardrobes. CPSC is aware of numerous deaths and injuries resulting from CSUs tipping over, particularly onto children. CPSC identified 226 fatalities associated with CSUs tipping over that were reported to have occurred between January 1, 2000 and December 31, 2020.<sup>1</sup> Of these, 193 (85 percent) involved children (*i.e.*, under 18 years old), 11 (5 percent) involved adults (*i.e.*, 18 to 64 years old), and 22 (10 percent) involved seniors (*i.e.*, 65 years and older). In addition, there were an estimated 78,200 nonfatal CSU tip-over injuries that were treated in U.S. hospital emergency departments (EDs) between January 1, 2006 and December 31, 2019. Of these, an estimated 56,400 (72 percent) involved children, and the remaining estimated 21,800 (28 percent) involved adults and seniors.

<sup>1</sup> Reporting is considered incomplete for the years 2018–2020 because reporting is ongoing.

To address the hazard associated with CSU tip overs, the Commission has taken several steps. In June 2015, the Commission launched the Anchor It! campaign. This educational campaign includes print and broadcast public service announcements; information distribution at targeted venues, such as childcare centers; social media; blog posts; videos; and an informational website ([www.AnchorIt.gov](http://www.AnchorIt.gov)). The campaign explains the nature of the risk, provides safety tips for avoiding furniture and television tip overs, and promotes the use of tip restraints to anchor furniture and televisions.

In addition, CPSC’s Office of Compliance and Field Operations has investigated and recalled CSUs. Between January 1, 2000 and March 31, 2021, 40 consumer-level recalls occurred to address CSU tip-over hazards. The recalled products were responsible for 328 tip-over incidents, including reports of 149 injuries and 12 fatalities.<sup>2</sup> These recalls involved 34 firms and affected approximately 21,500,000 CSUs.

In 2016, CPSC staff prepared a briefing package on furniture tip overs, looking at then-current levels of compliance with the voluntary standards, and the adequacy of the voluntary standards.<sup>3</sup>

In 2017, the Commission issued an advance notice of proposed rulemaking (ANPR), discussing the possibility of developing a rule to address the risk of injury and death associated with CSU tip overs. 82 FR 56752 (Nov. 30, 2017).<sup>4</sup> The ANPR began a rulemaking proceeding under the CPSA (15 U.S.C. 2051–2089). CPSC received 18 comments during the comment period, as well as five additional correspondences after the comment period, which staff also considered.

The Commission is now issuing a notice of proposed rulemaking (NPR), proposing to establish requirements for CSU stability.<sup>5</sup> The information discussed in this preamble is derived

<sup>2</sup> For the remaining incidents, either no injury resulted from the incident, or the report did not indicate whether an injury occurred.

<sup>3</sup> Massale, J., Staff Briefing Package on Furniture Tipover, U.S. Consumer Product Safety Commission (2016), available at: <https://www.cpsc.gov/s3fs-public/Staff%20Briefing%20Package%20on%20Furniture%20Tipover%20-%20September%2030%202016.pdf>.

<sup>4</sup> The briefing package supporting the ANPR is available at: [https://www.cpsc.gov/s3fs-public/ANPR%20-%20Clothing%20Storage%20Unit%20Tip%20Overs%20-%20November%2015%202017.pdf?5IsEEedW\\_Cb3ULO3TUGjHEl875Adhvsg](https://www.cpsc.gov/s3fs-public/ANPR%20-%20Clothing%20Storage%20Unit%20Tip%20Overs%20-%20November%2015%202017.pdf?5IsEEedW_Cb3ULO3TUGjHEl875Adhvsg). After issuing the ANPR, the Commission extended the comment period on the ANPR. 82 FR 2382 (Jan. 17, 2018).

<sup>5</sup> The Commission voted 4–0 to approve this notice.

from CPSC staff's briefing package for the NPR, which is available on CPSC's website at: <https://www.cpsc.gov/s3fs-public/Proposed%20Rule-%20Safety%20Standard%20for%20Clothing%20Storage%20Units.pdf>. This preamble provides key information to explain and support the rule; however, for a more comprehensive and detailed discussion, see the NPR briefing package.

## II. Statutory Authority

CSUs are "consumer products" that the Commission can regulate under the authority of the CPSA. *See* 15 U.S.C. 2052(a)(5). Section 7 of the CPSA authorizes the Commission to issue a mandatory consumer product safety standard that consists of performance requirements or requirements that the product be marked with, or accompanied by, warnings or instructions. *Id.* 2056(a). Any requirement in the standard must be "reasonably necessary to prevent or reduce an unreasonable risk of injury" associated with the product. *Id.* Section 7 requires the Commission to issue such a standard in accordance with section 9 of the CPSA. *Id.*

Section 9 of the CPSA specifies the procedure the Commission must follow to issue a consumer product safety standard under section 7. *Id.* 2058. Under section 9, the Commission may initiate rulemaking by issuing an ANPR or NPR. *Id.* 2058(a). As noted above, the Commission issued an ANPR on CSU tip overs in November 2017. 82 FR 56752 (Nov. 30, 2017). When issuing an NPR, the Commission must comply with section 553 of the Administrative Procedure Act (5 U.S.C. 553), which requires the Commission to provide notice of a rule and the opportunity to submit written comments on it. 15 U.S.C. 2058(d)(2). In addition, the Commission must provide interested parties with an opportunity to make oral presentations of data, views, or arguments. *Id.*

Under section 9 of the CPSA, an NPR must include the text of the proposed rule, any alternatives the Commission proposes, and a preliminary regulatory analysis. 15 U.S.C. 2058(c). The preliminary regulatory analysis must include:

- A preliminary description of the potential costs and benefits of the rule, including costs and benefits that cannot be quantified, and the analysis must identify who is likely to receive the benefits and bear the costs;
- a discussion of the reasons any standard or portion of a standard submitted to the Commission in

response to the ANPR was not published by the Commission as the proposed rule or part of the proposed rule;

- a discussion of the reasons for the Commission's preliminary determination that efforts submitted to the Commission in response to the ANPR to develop or modify a voluntary standard would not be likely, within a reasonable period of time, to result in a voluntary standard that would eliminate or adequately reduce the risk of injury addressed by the proposed rule; and

- a description of alternatives to the proposed rule that the Commission considered and a brief explanation of the reason the alternatives were not chosen.

*Id.*

In addition, to issue a final rule, the Commission must make certain findings and include them in the rule. *Id.* 2058(f)(1), (f)(3). Under section 9(f)(1) of the CPSA, before promulgating a consumer product safety rule, the Commission must consider, and make appropriate findings to be included in the rule, concerning the following issues:

- The degree and nature of the risk of injury the rule is designed to eliminate or reduce;
- the approximate number of consumer products subject to the rule;
- the need of the public for the products subject to the rule and the probable effect the rule will have on the cost, availability, and utility of such products; and
- the means to achieve the objective of the rule while minimizing adverse effects on competition, manufacturing, and commercial practices.

*Id.* 2058(f)(1). Under section 9(f)(3) of the CPSA, the Commission may not issue a consumer product safety rule unless it finds (and includes in the rule):

- The rule, including the effective date, is reasonably necessary to eliminate or reduce an unreasonable risk of injury associated with the product;
- that issuing the rule is in the public interest;
- if a voluntary standard addressing the risk of injury has been adopted and implemented, that either compliance with the voluntary standard is not likely to result in the elimination or adequate reduction of the risk or injury, or there is unlikely to be substantial compliance with the voluntary standard;
- that the benefits expected from the rule bear a reasonable relationship to its costs; and

- that the rule imposes the least burdensome requirement that prevents or adequately reduces the risk of injury. *Id.* 2058(f)(3). At the NPR stage, the Commission is making these findings on a preliminary basis to allow the public to comment on the findings.

Section 9(g)(2) of the CPSA allows the Commission to prohibit manufacturers of a consumer product from stockpiling products subject to a consumer product safety rule to prevent manufacturers from circumventing the purpose of the rule. 15 U.S.C. 2058(g)(2). The statute defines "stockpiling" as manufacturing or importing a product between the date a rule is promulgated and its effective date at a rate that is significantly greater than the rate at which the product was produced or imported during a base period ending before the date the rule was promulgated. *Id.* The Commission is to define what constitutes a "significantly greater" rate and the base period in the rule addressing stockpiling. *Id.*

Section 27(e) of the CPSA authorizes the Commission to issue a rule to require manufacturers of consumer products to provide "such performance and technical data related to performance and safety as may be required to carry out the purposes of [the CPSA]." 15 U.S.C. 2076(e). The Commission may require manufacturers to provide this information to the Commission or, at the time of original purchase, to prospective purchasers and the first purchaser for purposes other than resale, as necessary to carry out the purposes of the CPSA. *Id.* Section 2(b) of the CPSA states the purposes of the CPSA, including:

- Protecting the public from unreasonable risks of injury associated with consumer products; and
- assisting consumers in evaluating the comparative safety of consumer products.

*Id.* 2051(b)(1), (b)(2).

## III. The Product and Market

### A. Description of the Product

The proposed rule defines a "CSU" as a freestanding furniture item, with drawer(s) and/or door(s), that may be reasonably expected to be used for storing clothing, that is greater than or equal to 27 inches in height, and that has a total functional volume of the closed storage greater than 1.3 cubic feet and greater than the sum of the total functional volume of the open storage and the total volume of the open space. Common names for CSUs include, but are not limited to: Chests, bureaus, dressers, armoires, wardrobes, chests of drawers, drawer chests, chifforobes, and

door chests. CSUs are available in a variety of designs (e.g., vertical or horizontal dressers), sizes (e.g., weights and heights), dimensions, and materials (e.g., wood, plastic, leather, manufactured wood or fiber board). Consumers may purchase CSUs that have been assembled by the manufacturer, or they may purchase CSUs as ready-to-assemble furniture.

The proposed definition includes several criteria to help distinguish CSUs from other furniture. As freestanding furniture items, CSUs remain upright without requiring attachment to a wall, when fully assembled and empty, with all extension elements closed. As such, built-in units or units intended to be permanently attached to a building structure (other than by tip restraints) are not considered freestanding. In addition, CSUs are typically intended and used for storing clothing and, therefore, they are commonly used in bedrooms. However, consumers may also use CSUs in rooms other than bedrooms and to store items other than clothing in them. For this reason, whether a product is a CSU depends on whether it meets the criteria in the proposed definition, rather than what the name of the product is or what is the marketed use for the product. The criteria in the proposed definition regarding height and closed storage volume (i.e., storage space inside a drawer or behind an opaque door) aim to address the utility of a unit for holding multiple clothing items. Some examples of furniture items that, depending on their design, may not meet the criteria in the proposed definition and, therefore, may not be considered CSUs are: Shelving units, office furniture, dining room furniture, laundry hampers, built-in closets, and single-compartment closed rigid boxes (storage chests).

CSUs may be marketed, packaged, or displayed as intended for children 12 years old and younger. Examples of such products include CSUs with pictures or designs on them that would appeal to children; CSU designs that would be useful for children; or CSUs that are part of a matching set with a crib, or similar infant product. However, CSUs are more commonly general-use products that are not specifically intended for children 12 years old and younger. The proposed rule applies to both children's products and non-children's products.

#### B. The Market

CPSC staff estimated the annual revenues and shipments of CSUs, using estimates of manufacturer and importer revenue, and estimated sales, by using

data on retail sales. The shipment value of chests of drawers and dressers combined for an estimated \$5.15 billion in 2018, and combined shipments of dressers and chests totaled 43.6 million units. Average manufacturer shipment value was \$118 per unit in 2018 (about \$104 for chests of drawers and \$144 for dressers).

Retail prices of CSUs vary substantially. The least expensive units retail for less than \$100, while more expensive units may retail for several thousand dollars. The estimated retail value of U.S. bedroom furniture sales in 2019 totaled \$60.3 billion, of which \$20.8 billion was sales of closets (which likely includes wardrobes and armoires), nightstands (some of which may be considered CSUs), and dressers (which likely includes chests of drawers).

According to data from the U.S. Census Bureau, in 2017, there were a total of 3,404 firms classified in the North American Industrial Classification System (NAICS) as non-upholstered wood household furniture manufacturing, upholstered household furniture manufacturing, metal household furniture manufacturing, or household furniture (except wood and metal) manufacturing. Of these firms, 2,024 were primarily categorized in the non-upholstered wood furniture category. However, these categories are broad and include manufacturers of furniture other than CSUs, such as tables, chairs, bed frames, and sofas. As such, it is likely that not all of the firms in these categories manufacture CSUs. Production methods and efficiencies vary among manufacturers; some use mass production techniques, and others manufacture their products one at a time or on a custom-order basis.

The number of U.S. firms that are primarily classified as manufacturers of non-upholstered wood household furniture has declined over the last few decades, as retailers have turned to international sources of CSUs and other wood furniture. Additionally, some firms that formerly produced all of their CSUs domestically have shifted production to foreign plants. More than half (64 percent) of the value of apparent consumption of non-upholstered wood furniture (net imports plus domestic production for the U.S. market) in 2019 was comprised of imported furniture, which may be true for CSUs as well. In addition to manufacturers, according to the Census Bureau data, in 2017, there were 5,117 firms involved in household furniture importation and distribution. According to the Census Bureau, there were 13,826 furniture retailers in 2017. Wholesalers

and retailers may obtain their products from domestic sources or import them from foreign manufacturers.

## IV. Risk of Injury

### A. Incident Data<sup>6</sup>

CPSC staff analyzed reported fatalities, reported nonfatal incidents and injuries, and calculated national estimates of injuries treated in EDs that were associated with CSU instability or tip overs. Each year, CPSC issues an annual report on furniture instability and tip overs.<sup>7</sup> The information provided for this rulemaking is drawn from a subset of data from those annual reports, as well as from the National Electronic Injury Surveillance System<sup>8</sup> (NEISS), which includes reports of injuries treated in U.S. EDs, and the Consumer Product Safety Risk Management System<sup>9</sup> (CPSRMS). For this rulemaking, staff focused on incidents that involved products that would be considered CSUs.<sup>10</sup> Staff considered incidents that involved the CSU tipping over, as well as incidents of CSU instability with indications of impending tip over. Tip-over incidents are a subset of product instability incidents, and involve CSUs actually falling over. Product instability incidents are a broader category that includes tip-over incidents, but may also include incidents where CSUs did not fully tip over. Staff considered instability incidents relevant because product instability can lead to a tip over, and the same factors, such as product design, can contribute to instability and tip overs.<sup>11</sup>

The data presented here represent the minimum number of incidents or

<sup>6</sup> For more details about incident data, see Tab A of the NPR briefing package.

<sup>7</sup> These annual reports are available at: <https://www.cpsc.gov/Research--Statistics/Furniture-and-Decor-1>.

<sup>8</sup> Data from NEISS is based on a nationally representative probability sample of about 100 hospitals in the United States and its territories. NEISS data can be accessed from the CPSC website under the "Access NEISS" link at: <https://www.cpsc.gov/Research--Statistics/NEISS-Injury-Data>.

<sup>9</sup> CPSRMS is the epidemiological database that houses all anecdotal reports of incidents received by CPSC, "external cause"-based death certificates purchased by CPSC, all in-depth investigations of these anecdotal reports, as well as investigations of select NEISS injuries. Examples of documents in CPSRMS include: Hotline reports, internet reports, news reports, medical examiner's reports, death certificates, retailer/manufacturer reports, and documents sent by state/local authorities, among others.

<sup>10</sup> Staff considered incidents that involved chests, bureaus, dressers, armoires, wardrobes, portable clothes lockers, and portable closets.

<sup>11</sup> This section refers to tip-over incidents and instability incidents collectively as tip-over incidents.

fatalities during the time frames described. Data collection is ongoing for CPRMS, and is considered incomplete for 2018 and after, so CPSC may receive additional reports for those years in the future.<sup>12</sup>

### 1. Fatal Incidents

Based on NEISS and CPRMS, CPSC staff identified 193 reported CSU tip-over fatalities to children (*i.e.*, under 18 years old),<sup>13</sup> 11 reported fatalities to adults (*i.e.*, ages 18 through 64 years), and 22 reported fatalities to seniors (*i.e.*, ages 65 years and older) that were reported to have occurred between January 1, 2000 and December 31, 2020.<sup>14</sup> Of the 193 reported CSU tip-over child fatalities, 89 (46 percent) involved only a CSU tipping over, whereas, 104 (54 percent) involved a CSU and a television tipping over. Of the child fatalities, 190 (98 percent) involved a chest, bureau, or dresser, 2 involved a wardrobe, and 1 involved an armoire. Of the 33 reported adult and senior fatalities, 32 (97 percent) involved only a CSU tipping over, whereas, 1 (9 percent) involved both a CSU and a television tipping over. Of the adult and senior fatalities, 29 involved a chest, bureau, or dresser, 2 involved a wardrobe, 1 involved an armoire, and 1 involved a portable storage closet.

For the years for which reporting is considered complete—2000 through 2017—there have been from 3 to 21 child fatalities each year from CSU tip overs, and from 0 to 5 fatalities each year to adults and seniors.

Of the 193 reported child fatalities from tip overs, 166 involved children 3 years old or younger; 12 involved 4-year-olds; 7 involved 5-year-olds; 4 involved 6-year-olds; 1 involved a 7-year-old; and 3 involved 8-year-olds. Of

the 89 reported child fatalities from tip overs involving only CSUs (*i.e.*, no televisions), 84 involved children 3 years old or younger; 2 involved 4-year-olds; 1 involved a 5-year-old; 1 involved a 6-year-old; and 1 involved a 7-year-old. Thus, 94 percent of these fatalities were children 3 years old and younger; 97 percent were 4 years old and younger; 98 percent were 5 years old and younger; and 99 percent were 6 years old and younger. Therefore, regardless of television involvement, the most reported CSU tip-over fatalities happened to children 3 years old or younger. Among children 4 years and older, a television was more frequently involved than not involved.

CSU tip-over fatalities to children were most commonly caused by torso injuries when only a CSU was involved, and were more commonly caused by head injuries when both a CSU and television tipped over. For the 89 child fatalities not involving a television, 58 resulted from torso injuries (chest compression); 13 resulted from head/torso injuries; 12 resulted from head injuries; 4 involved unknown injuries; and 2 involved a child's head, torso, and limbs pinned under the CSU. For the 104 child fatalities that involved both a CSU and television tipping over, 91 resulted from head injuries (blunt head trauma); 6 resulted from torso injuries (chest compression resulting from the child being pinned under the CSU); 2 resulted from head/torso injuries; 4 involved unknown injuries; and 1 involved head/torso/limbs.

### 2. Reported Nonfatal Incidents

CPSC staff identified 1,002 reported nonfatal CSU tip-over incidents for all ages that were reported to have occurred between January 1, 2005 and December 31, 2020.<sup>15</sup> CPRMS reports are considered anecdotal because, unlike NEISS data, they cannot be used to identify statistical estimates or year-to-year trend analysis, and because they include reports of incidents in which no injury resulted. Although these anecdotal data do not provide for statistical analyses, they provide detailed information to identify hazard patterns, and provide a minimum count of injuries and deaths.

Of the 1,002 reported incidents, 64 percent (639 incidents) involved only a CSU, and 36 percent (363 incidents) involved both a CSU and television

tipping over. Of the 1,002 incidents, 99.5 percent (997 incidents) involved a chest, bureau, or dresser; less than 1 percent (4 incidents) involved an armoire; and less than 1 percent (1 incident) involved a wardrobe.

For the years for which reporting is considered complete—2005 through 2017—there were from 6 to 256 reported nonfatal CSU tip-over incidents each year, with 2016 (256 incidents) and 2017 (101 incidents) reporting the highest number of incidents. Each year, there were from 5 to 232 reported nonfatal incidents involving only a CSU, with the highest number (232 incidents) occurring in 2016.

Of the 1,002 nonfatal CSU tip-over incidents reported, 362 did not mention any specific injuries; 628 reported one injury; and 12 reported two injuries, resulting in a total of 652 injuries reported among all of the reported nonfatal incidents. Of these 652 reported injuries, 64 (10 percent) resulted in hospital admission; 296 (45 percent) were treated in EDs; 28 (4 percent) were seen by medical professionals; and the level of care is unknown<sup>16</sup> for the remaining 264 (40 percent). Of 293 reports of nonfatal CSU tip-over injuries where only a CSU was involved; 7 resulted in hospital admission (of which 6 were children<sup>17</sup>); 23 were treated in the ED (of which 22 were children); 27 were seen by a medical professional (of which 19 were children); and the level of care is unknown for the remaining 236.

Of the victims whose ages were known, there were more injuries suffered by children 3 years old and younger, than to older victims; and the injuries suffered by these young children tended to be more severe, compared to older children and adults/seniors. The severity of injury ranged from cuts and bumps to concussions and skull fractures. Of the 7 victims admitted to the hospital, 5 were 3 years old or younger; 1 was a child of unknown age; and 1 was an adult. Of the 23 victims treated in the ED, 8 were 3 years old or younger; 4 were 4 to 5 years old; 4 were 6 to 17 years old; and 6 were children of unknown age.

<sup>16</sup> These reports include bruising, bumps on the head, cuts, lacerations, scratches, application of first-aid, or other indications of at least a minor injury that occurred, without any mention of aid rendered by a medical professional. There were three NEISS cases in which the victim went to the ED, but then left without being seen.

<sup>17</sup> Incidents involving children include those in which the age of the victim was reported as well as those in which the age was not reported, but the report included indications that the victim was a child (*e.g.*, a sibling of a small child, or referred to as a “child,” “daughter,” or “son”). For the remaining incidents, the victim was either an adult, or the age was unknown.

<sup>12</sup> Among other things, CPRMS houses all in-depth investigation reports, as well as the follow-up investigations of select NEISS injuries. As such, it is possible for a NEISS injury case to be included in the national injury estimate, while its investigation report is counted among the anecdotal nonfatal incidents, or for a NEISS injury case to appear on both the NEISS injury estimate and fatalities, if the incident resulted in death while receiving treatment.

<sup>13</sup> Of the 193 reported fatalities, there was one tip-over incident that resulted in two deaths, making the number of fatal incidents 192.

<sup>14</sup> Different time frames are presented for NEISS, CPRMS, fatal, and nonfatal data because of the timeframes in which staff collected, received, retrieved, and analyzed the data. One example of the reason for varied timeframes is that staff drew data from previous annual reports and other data-collection reports (which used varied start dates), and then updated the data set to include more recent data. Another example is that CPRMS data are available on an ongoing basis, whereas NEISS data are not available until several months after the end of the previous calendar year.

<sup>15</sup> Nonfatal incident reports submitted to CPSC come from reports entered into CPSC's CPRMS database no later than December 31, 2020, and includes completed NEISS investigations. All of the investigation reports based on NEISS injuries that occurred from 2006 through 2020 appear in the reported nonfatal incidents.



### 3. National Estimates of ED-Treated Injuries<sup>18</sup>

According to NEISS, there were an estimated 78,200 injuries,<sup>19</sup> an annual average of 5,600 estimated injuries, related to CSU tip overs for all ages that were treated in U.S. hospital EDs from January 1, 2006 to December 31, 2019. Of the estimated 78,200 injuries, 56,400 (72 percent) were to children, which is an annual average of 4,000 estimated injuries to children over the 14-year period. For the remaining estimated 21,800 injuries to adults and seniors, about 3,200 (15 percent) were to seniors (*i.e.*, 65 years and older).

An estimated 61,700 (79 percent) of ED-treated injuries involved only a CSU tipping over, whereas, an estimated 16,500 (21 percent) involved both a CSU and television tipping over. This ratio was similar for injuries to children, with an estimated 40,700 (72 percent) of child incidents involving only a CSU, and an estimated 15,700 (28 percent) involving both a CSU and a television. In contrast, nearly all (an estimated 21,000 or 96 percent) of the estimated injuries to adults and seniors involved only a CSU. For each year from 2006 through 2019, there have been more estimated ED-treated injuries to children involving only a CSU tipping over, compared to incidents involving a CSU and a television tipping over.

For all ages, an estimated 77,000 (98 percent) of the ED-treated injuries involved a chest, bureau, or dresser. Similarly, for child injuries, an estimated 55,800 (99 percent) involved a chest, bureau, or dresser.<sup>20</sup> Of the ED-treated injuries to all ages, 93 percent were treated and released, and 4 percent were hospitalized. Among children, 93 percent were treated and released, and 3 percent were hospitalized.

For each year from 2006 through 2019, there were an estimated 2,500 to 5,900 ED-treated injuries to children from CSU tip overs. The estimated annual number of ED-treated injuries to adults and seniors from CSU tip overs is fairly consistent over most of the 14-year period, with an overall yearly average of 1,600 estimated injuries, although data were insufficient to support reliable statistical estimates for

adults and seniors for 2014, 2015, and 2019.

CPSC focused on ED-treated injuries involving children because these make up the majority of ED-treated CSU tip-over injuries. For 2010 through 2019, there is a statistically significant linear decline in child injuries involving CSU tip overs (both with and without televisions);<sup>21</sup> however, there is no linear trend detected in injuries to children involving only CSUs tipping over. This indicates that the statistically significant decrease in all CSU tip overs involving children is driven by the decline in tip overs involving televisions, while the rate of ED-treated incidents involving CSUs without televisions has remained stable.

Of the estimated ED-treated injuries to children, most involved 2- and 3-year-olds, followed by 1- and 4-year-olds. An estimated 7,900 ED-treated injuries involved 1-year-olds;<sup>22</sup> an estimated 15,000 involved 2-year-olds;<sup>23</sup> an estimated 13,000 involved 3-year-olds;<sup>24</sup> and an estimated 7,500 involved 4-year-olds.<sup>25</sup> There were an estimated 2,300 injuries to 5-year-olds that involved only a CSU, and an estimated 1,800 injuries to 6-year-olds that involved only a CSU, but data were insufficient to support reliable statistical estimates for incidents involving CSUs and televisions for these ages. For children 7 to 17 years old,<sup>26</sup> there were an estimated 4,700 ED-treated injuries involving only a CSU, and an estimated 1,600 involving a CSU and a television.

Of the estimated 56,400 ED-treated CSU tip-over injuries to children, an estimated 20,800 (37 percent) resulted in contusions/abrasions;<sup>27</sup> an estimated 14,900 (26 percent) resulted in internal organ injury (including closed head injuries);<sup>28</sup> an estimated 7,600 (13 percent) resulted in lacerations;<sup>29</sup> an estimated 5,200 (9 percent) resulted in

fractures;<sup>30</sup> and the remaining estimated 7,800 (14 percent) resulted in other diagnoses.

Overall, an estimated 33,700 (60 percent) of ED-treated tip-over injuries to children were to the head, neck, or face; and an estimated 10,300 (18 percent) were to the leg, foot, or toe. The injuries to children were more likely to be head injuries when a television was involved than when no television was involved. Of the estimated number of ED-treated injuries to children involving a CSU and a television, 73 percent were head injuries, compared to 55 percent of injuries involving only a CSU. In addition, of the estimated injuries to children involving only a CSU, 20 percent were leg, foot, or toe injuries, and 14 percent were trunk or torso injuries. Data were insufficient to generate estimates of trunk/torso or arm/hand/finger injuries when both a CSU and television tipped over.

#### B. Details Concerning Injuries<sup>31</sup>

To assess the types of injuries that result from CSU tip overs, CPSC staff focused on incidents involving children, because the vast majority of CSU tip overs involve children. The types of injuries resulting from furniture tipping over onto children include soft tissue injuries, such as cuts and bruises (usually a sign of internal bleeding); skeletal injuries and bone fractures to arms, legs, and ribs; and potentially fatal injuries resulting from skull fractures, closed-head injuries, compressional and mechanical asphyxia, and internal organ crushing leading to hemorrhage. These types of injuries can result from tip overs involving CSUs alone, or CSUs with televisions.

As explained above, head injuries and torso injuries are common in CSU tip overs involving children. The severity of injuries depends on a variety of factors, but primary determinants include the force generated at the point of impact, the entrapment time, and the body part impacted. The head, neck, and chest are the most vulnerable. The severity of injury can also depend on the orientation of the child's body or body part when it is hit or trapped by the CSU. Sustained application of a force that affects breathing can lead to compressional asphyxia and death. In most CSU tip-over cases, serious injuries and death are a result of blunt force trauma to the head and intense pressure on the chest causing

<sup>18</sup> Estimates are rounded to the nearest hundred and may not sum to total, due to rounding. NEISS estimates are reportable, provided the sample count is greater than 20, the national estimate is 1,200 or greater, and the coefficient of variation (CV) is less than 0.33.

<sup>19</sup> Sample size = 2,629, coefficient of variation = .0667.

<sup>20</sup> Data on armoires, wardrobes, portable closets, and clothes lockers were insufficient to support reliable statistical estimates.

<sup>21</sup> There were not enough CSU ED-treated incidents to children involving both a CSU and a television to make reliable estimates for the most recent 5 years, 2015 through 2019.

<sup>22</sup> An estimated 6,300 involved only a CSU and the remaining 1,600 involved a CSU and television.

<sup>23</sup> An estimated 10,600 involved only a CSU, and the remaining 4,400 involved a CSU and television.

<sup>24</sup> An estimated 9,200 involved only a CSU, and the remaining 3,800 involved a CSU and television.

<sup>25</sup> An estimated 5,100 involved only a CSU, and the remaining 2,400 involved a CSU and television.

<sup>26</sup> These ages are grouped together because data were insufficient to generate estimates for any single age within that range.

<sup>27</sup> Seventy-six percent of these involved only a CSU, and the remainder involved a CSU and television tipping over.

<sup>28</sup> Sixty-one percent of these involved only a CSU, and the remainder involved a CSU and television tipping over.

<sup>29</sup> Eighty-two percent of these involved only a CSU, and the remainder involved a CSU and television tipping over.

<sup>30</sup> Sixty-nine percent of these involved only a CSU, and the remainder involved a CSU and television tipping over.

<sup>31</sup> For more details about injuries, see Tab B of the NPR briefing package.

respiratory and circulatory system impairment.

Head injuries are produced by high-impact forces applied over a small area and can have serious clinical consequences, such as concussions and facial nerve damage. Such injuries are often fatal, even in cases where the child is immediately rescued and there is rapid intervention. An incident involving blunt head trauma can result in immediate death or loss of consciousness. Autopsies from CSU tip-over fatalities to children reported crushing injuries to the skull and regions of the eye and nose. Brain swelling, deep scalp hemorrhaging, traumatic intracranial bleeding, and subdural hematomas were often reported. These types of injuries are typical of crush injuries caused by blunt head trauma and often have a fatal outcome. Children who survive such injuries may suffer neurological deficits, require neurosurgical interventions, and can face lifelong disabilities.

Compressional and mechanical asphyxia is another potential cause of injury and death in CSU tip-over incidents. Asphyxia can be fatal within minutes. In multiple CSU tip-over incidents, there was physical evidence of chest compression visible as linear marks or abrasions across the chest and neck, consistent with the position of the CSU. Compressional and mechanical asphyxia can result from mechanical forces generated by the sheer mass of an unyielding object, such as furniture, acting on the thoracic and abdominal area of the body, which prevents thorax expansion and physically interferes with the coordinated diaphragm and chest muscle movement that normally occurs during breathing. Torso injuries, which include compressional and mechanical asphyxia, are the most common form of injury for non-television CSU fatalities. External pressure on the chest that compromises the ability to breathe by restricting respiratory movement or on the neck can cause oxygen deprivation (hypoxia). Oxygen deprivation to the brain can cause unconsciousness in less than three minutes and may result in permanent brain damage or death when pressure is applied directly on the neck by the CSU or a component of the CSU (such as the edge of a drawer). The prognosis for a hypoxic victim depends on the degree of oxygen deprivation, the duration of unconsciousness, and the speed at which cardiovascular resuscitation attempts are initiated relative to the timing of cardiopulmonary arrest. Rapid reversal of the hypoxic state is essential to prevent or limit the development of

pulmonary and cerebral edema that can lead to death or other serious consequences. The sooner the CSU (compression force) is removed and resuscitation initiated, the greater the likelihood that the patient will regain consciousness and recover from injuries.

In addition to chest compression, pressure on the neck by a component of the CSU can also result in rapid strangulation due to pressure on the blood vessels in the neck. The blood vessels that take blood to and from the brain are relatively unprotected in the soft tissues of the neck and are vulnerable to external forces. Sustained compression of either the jugular veins or the carotid arteries can lead to death. Petechial hemorrhages of the head, neck, chest, and the periorbital area were reported in autopsy reports of CSU tip-over incidents.

Pediatric thoracic trauma has unique features that differ from adult thoracic trauma, because of differences in size, structure, posture, and muscle tone. While the elasticity of a child's chest wall reduces the likelihood of rib fracture, it also provides less protection from external forces. Impact to the thorax of an infant or small child can produce significant chest wall deflection and transfer large kinetic energy forces to vital thoracic organs such as the lungs and heart, which can cause organ deflection and distention and lead to traumatic asphyxia, or respiratory and circulatory system impairment or failure. In addition, a relatively small blood volume loss in a child, due to internal organ injuries and bleeding, can lead to decreased blood circulation and shock.

The severity of the injury or likelihood of death can be reduced if a child is quickly rescued. However, children's ability to self-rescue is limited because of their limited cognitive awareness of hazards, limited skills to react quickly, and limited strength to remove the fallen CSU. Moreover, many injuries can result in immediate death or loss of consciousness, making self-rescue impossible.

#### *C. Hazard Characteristics*<sup>32</sup>

To identify hazard patterns associated with CSU tip overs, CPSC focused on incidents involving children and CSUs without televisions because the majority of fatal and nonfatal incidents involve children and, in recent years, there has been a statistically significant decrease in the overall number of ED-treated CSU

tip-over incidents that appears to be driven by a decline in incidents involving CSUs with televisions, while the rate of ED-treated incidents involving CSUs without televisions has remained stable. Staff used NEISS and CPSRMS reports to identify hazard patterns, including In-Depth-Investigation (IDI) reports, and also considered child development and capabilities, as well as online videos of real-life child interactions with CSUs and similar furniture items (including videos of tip-over incidents).

#### 1. Filled Drawers

Of the 89 fatal CPSRMS incidents involving children and only CSUs, 53 (59 percent) provided information about whether the CSU drawers contained items at the time of the tip over. Of those 53 incidents, 51 (96 percent) involved partially filled or full drawers. Of the 263 nonfatal CPSRMS tip overs involving children and only CSUs, drawer fill level was reported for 67 incidents (25 percent). Of these 67 incidents, 60 (90 percent) involved partially filled or full drawers.<sup>33</sup> CPSRMS incidents show that most items in the drawers were clothing, although a few mentioned other items along with clothing (e.g., diaper bag, toys, papers).

#### 2. Interactions

Of the 89 fatal CPSRMS tip overs involving children and only a CSU, 47 reported the type of interaction the child had with the CSU at the time of the incident. Of these 47 incidents, 35 (74 percent) involved a child climbing on the CSU; 8 (17 percent) involved a child sitting, laying, or standing in a drawer; and 4 (9 percent) involved a child opening drawers. Climbing was the most common reported interaction for children 3 years old and younger.

Of the 263 nonfatal CPSRMS tip-over incidents involving children and only CSUs, the type of interaction was reported in 160 incidents. Of these, 101 (63 percent) involved opening drawers; 32 (20 percent) involved climbing on the CSU; 10 (6 percent) involved putting items in/taking them out of a drawer; 9 (6 percent) involved pulling on the CSU; 5 (3 percent) involved leaning or pushing down on an open drawer; 2 (1 percent) involved another interaction; and 1 (less than 1 percent) involved a child in the drawer. Opening drawers was the most common reported interaction for children 6 years old and younger, and was particularly common for 2- and 3-year-olds.

<sup>32</sup> For additional information about hazard patterns, see Tab C of the NPR briefing package.

<sup>33</sup> Nonfatal NEISS incident reports did not contain information on drawer fill level or contents.

Of the 1,463 nonfatal NEISS incidents involving children and only CSUs, the type of interaction was reported in 559 incidents. Of these, the child was injured because of another person's interaction with the CSU in 22 incidents; the remaining 537 incidents involved the child interacting with the CSU. Of these 537 incidents, 412 (77 percent) involved climbing on the CSU; 42 (8 percent) involved opening drawers; and the remaining 83 incidents (15 percent) involved a child in the drawer, pulling on the CSU, putting items in or taking items out of a drawer, reaching, hitting, jumping, a child on top of the CSU, playing in a drawer, pulling up, swinging, or other interaction. For children 3 years old or younger, climbing constituted almost 80 percent of reported interactions. Overall, 81 percent (438 of 537) of the reported interactions in the nonfatal NEISS tip-over incidents involving children and only CSUs are those in which the child's weight was supported by the CSU (e.g., climbing, in drawer, jump, on top, swinging), and 12 percent (64 of 537) were interactions in which the child's strength determines the force (e.g., hit, opening drawers, pulled on, pulled up).

Thus, in fatal incidents, a child climbing on the CSU was, by far, the most common reported interaction; and in nonfatal incidents, opening drawers and climbing were the most common reported interactions. These interactions are examined further, below.

To learn more about children's interactions with CSUs during tip-over incidents, CPSC staff also reviewed videos, available from news sources, articles, and online, that involved children interacting with CSUs and similar products, and CSU tip overs. Videos of children climbing on CSUs and similar items show a variety of climbing techniques, including stepping on the top of the drawer face, stepping on drawer knobs, using the area between drawers as a foothold, gripping the top of an upper drawer with their hands, pushing up using the top of a drawer, and using items to help climb. Videos of children in drawers of CSUs and other similar products include children leaning forward and backward out of a drawer; sitting, lying, and standing in a drawer; and bouncing in a drawer. Some videos also show multiple children climbing a CSU or in a drawer simultaneously.

#### a. Climbing

As discussed above, climbing on the CSU was one of the primary interactions involved in CSU tip overs involving children and only a CSU. It was the

most common reported interaction (74 percent) in fatal CPSRMS incidents; it was the most common reported interaction (77 percent) in nonfatal NEISS incidents; and it was the second most common reported interaction (20 percent) in nonfatal CPSRMS incidents.

Children as young as 9 months, and up to 13 years old were involved in climbing incidents. Fatal climbing incidents most often involved 1-, 2-, and 3-year-old children, and nonfatal climbing incidents most often involved 2- and 3-year-old children. Of climbing incidents with a reported age, the children were 3 years old or younger in 94 percent (33 of 35) of the fatal CPSRMS incidents; 73 percent (301 of 412) of the nonfatal NEISS incidents; and 63 percent (17 of 27) of the nonfatal CPSRMS incidents.

The prevalence of children climbing during CSU tip overs is consistent with the expected motor development of children. Between approximately 1 and 2 years old, children can climb on and off of furniture without assistance, use climbers, and begin to use playground apparatuses independently; and 2-year-olds commonly climb. The University of Michigan Transportation Research Institute (UMTRI) focus groups on child climbing (the UMTRI study is described in section VII.B. Forces and Moments During Child Interactions with CSUs of this preamble) demonstrated these abilities, with child participants showing interest in climbing CSUs and other furniture.

#### b. Opening Drawers

As discussed above, opening the drawers of a CSU was a common interaction in CSU tip overs involving children and only a CSU. It was the most common reported interaction (63 percent) in nonfatal CPSRMS incidents; it was the second most common reported interaction (8 percent) in nonfatal NEISS incidents; and it was the third most common reported interaction (9 percent) in fatal CPSRMS incidents.

Children as young as 11 months, and up to 14 years old were involved in incidents where the child was opening one or more drawers of the CSU. In nonfatal CPSRMS incidents, opening drawer incidents most commonly involved 2-year-olds; in nonfatal NEISS incidents, opening drawer incidents most commonly involved 3-year-olds, followed by 2-year-olds, followed by 4-year-olds, followed by children under 2 years old; and in nonfatal CPSRMS incidents, opening drawer incidents most commonly involved 3-year-olds, followed by 2-year-olds. Children of all ages were able to open at least one drawer.

Looking at both fatal and nonfatal CPSRMS tip overs involving children and only CSUs, where the interaction involved opening drawers, overall, about 53 percent involved children opening one drawer, 10 percent involved opening two drawers, and almost 17 percent involved opening "multiple" drawers. In several incidents (23 CPSRMS incidents), children opened "all" of the drawers; it is possible that additional incidents, mentioning a specific number of open drawers (between 2 and 8), also involved all the drawers being opened. In incidents where all of the drawers were open, the CSUs ranged from 2-drawer to 8-drawer units. The youngest child reported to have opened all drawers was 13 months old.

Consistent with these incident data, the UMTRI child climbing study found that caregivers commonly reported that their children opened and closed drawers when interacting with furniture.

It is possible for CSUs to tip over from the forces generated by open drawers and their contents, alone, without additional interaction forces. However, pulling on a drawer to open it can apply increased force that contributes to instability. Once a drawer is fully opened, any additional pulling is on the CSU as a whole. The pull force, and the height of the drawer pull location, relative to the floor, are relevant considerations. To examine this factor, staff assessed 15 child incidents in which the height of the force application could be calculated based on descriptions of the incidents. Force application heights ranged from less than one foot to almost four feet (46.5 inches), and children pulled on the lowest, highest, and drawers in between.

#### c. Opening Drawers and Climbing Simultaneously

CPSC staff also examined incidents in which both climbing and open drawers occurred simultaneously. Of the 35 fatal CPSRMS climbing incidents, 13 reported the number of drawers open; in all of these incidents, the reported number of drawers open was one, although, based on further analysis, the number of open drawers could be as high as 8 in one incident.<sup>34</sup> Of the 32 nonfatal CPSRMS climbing incidents, 15 gave some indication of the number of open drawers. Of these, 7 reported that one drawer was open, 2 reported

<sup>34</sup> CPSC staff analysis suggests that 7 or more drawers of an 8-drawer unit were open and the child was in a drawer leaning out over the edge in a fatal incident. This analysis is described in Tab M of the NPR briefing package, as Model E.

that half or less of the drawers were open, 4 reported that multiple drawers were open, and 2 reported that all the drawers were open. In the 2 cases where all drawers were open, the children were 3 and 4 years old. Of the 412 climbing incidents in the nonfatal NEISS data, 28 gave some indication of the number of open drawers. Of these, 11 reported that one drawer was open, 12 reported that multiple drawers were open, 1 reported that two drawers were open, and 2 reported that all drawers were open. These data are consistent with the videos staff reviewed, which show a range of drawer positions when children climbed on units, including all drawers closed, one drawer open, multiple drawers open, and all drawers fully open.

There is limited information in the incident data about children's interaction with doors on CSUs, as opposed to interactions with drawers. Staff found two fatal CPSRMS and four nonfatal CPSRMS tip-over incidents involving wardrobes and armoires, which include doors. In one of the fatal incidents, the victim was found inside a wardrobe that had two doors and one drawer, suggesting that the child opened the doors of the wardrobe. In the other fatal incident, the victim was found under a two-door wardrobe. In most of the nonfatal incidents involving wardrobes or armoires, children were reportedly interacting with items inside the unit, which would require them to open the doors. The ages of the children in these incidents ranged from 3 to 11 years, although opening doors is easily within the physical and cognitive abilities of younger children.

These incidents indicate that children can and do open CSU doors. There is no direct evidence in the incident data that, once CSU doors are open, children put their body weight on the open doors (*i.e.*, open and climbing). However, this is a plausible interaction based on child capabilities, provided that the child has a sufficient hand hold.

#### d. Differences in Interactions by Age

Based on the incident data, children 3 years old and younger climb, open drawers without climbing, get items in and out of drawers, lean on open drawers, push down on open drawers, sit or lie in bottom drawers, or stand on open bottom drawers. Among fatal CPSRMS tip-over incidents involving children and only CSUs, climbing was the most common interaction for children 3 years old and younger; this drops off sharply for 4-year-olds. Starting at 4 years old, children do not appear to sit or lie in bottom drawers of a CSU. Among nonfatal CPSRMS tip-

over incidents involving children and only CSUs, opening drawers was, by far, the most common interaction for children 7 years old and younger; and climbing was also common among 3-year-olds and, to a lesser extent, among 2- and 4-year-olds. Among nonfatal NEISS tip overs involving children and only CSUs, climbing was common for 2- and 3-year-olds, slightly less common for 4-year-olds and children under 2 years, and dropped off further for children 5 years and older.

#### 3. Flooring

Of the 89 fatal CPSRMS tip overs involving children and only CSUs, the type of flooring under the CSU was reported for 55 incidents. Of these, 45 (82 percent) involved carpeting, which includes rugs; 8 (15 percent) involved wood, hardwood, or laminate wood flooring; and 2 (4 percent) involved tile or linoleum flooring. The reports for 30 of the fatal CPSRMS tip-over incidents involving carpet included photos with visible carpet. All carpet in these pictures appeared to be typical wall-to-wall carpeting. Four appeared to be a looped pile carpet, and 26 appeared to be cut pile. Staff also identified two incidents with reported "shag" carpeting, including one fatal incident. Staff found one report mentioning a rug, although the thickness of the rug is unknown.

Of the 263 nonfatal CPSRMS tip overs involving children and only CSUs, the type of flooring under the CSU was reported for 60 incidents. Of these, 48 (80 percent) involved carpeting, which includes rugs; 10 (17 percent) involved wood, hardwood, or laminate wood flooring; 1 (2 percent) involved tile or linoleum flooring; and 1 (2 percent) indicated that the front legs of the CSU were on carpet while the back legs were on wood flooring.<sup>35</sup>

Thus, for incidents where flooring type was reported, carpet was, by far, the most prevalent flooring type.

#### 4. Characteristics of Children in Tip-Over Incidents

##### a. Age of Children

Children in fatal CPSRMS tip-over incidents involving only CSUs were 11 months through 7 years old. A total of 33 fatal incidents involved children under 2 years old; 30 involved 2-year-old children; 21 involved 3-year-olds; 2 involved 4-year-olds; and 1 incident each involved 5-, 6-, and 7-year-old children. Among the nonfatal CPSRMS tip-over incidents involving children and only CSUs where age was reported,

<sup>35</sup> Flooring type was not reported in nonfatal NEISS incident reports.

3-year-olds were involved in the highest number of incidents (59 incidents), followed by 2-year-olds (47 incidents).

Nonfatal NEISS tip-over incidents involving children and only CSUs follow a similar distribution, with the highest number of reported incidents involving 2-year-olds, followed by 3-year-olds, and children less than 2 years. Further details regarding the age of children involved in CSU tip overs is available in the discussion of incident data, above.

##### b. Weight of Children

Among the 89 fatal CPSRMS tip-over incidents involving children and CSUs without televisions, the child's weight was reported in 49 incidents and ranged from 18 pounds to 45 pounds. Where weight was not reported, staff used the most recent Centers for Disease Control and Prevention (CDC) Anthropometric Reference to estimate the weight of the children.<sup>36</sup> Staff used the 50th percentile values of weight that correspond to the victims' ages to estimate the weight range of the children. For the remaining 40 fatal CPSRMS incidents without a reported weight, the estimated weight range was 19.6 pounds to 45.1 pounds.

Among the 263 nonfatal CPSRMS incidents involving children and only CSUs, the weights of 47 children were reported, ranging from 26 pounds to 80 pounds. Where it was not reported, staff again estimated the weight of the children using the 50th percentile values of weight that correspond to the victims' ages from the most recent CDC Anthropometric Reference. The estimated child weights for the 164 nonfatal CPSRMS incidents without a reported child weight, but with a reported age (which included a 17-year-old), ranged from 19.6 pounds to 158.9 pounds.

Although nonfatal NEISS incident data did not include the children's weights, staff again estimated the children's weights by age, determining that for tip overs involving only CSUs, the estimated weights of the children ranged from 15.8 pounds to 158.9 pounds (this covered children from 3

<sup>36</sup> Fryar, C.D., Carroll, M.D., Gu, Q., Afful, J., Ogden, C.L. (2021). Anthropometric reference data for children and adults: United States, 2015–2018. National Center for Health Statistics. *Vital Health Stat 3(46)*. The CDC Anthropometric Reference is based on a nationally representative sample of the U.S. population, and the 2021 version is based on data collected from 2015 through 2018. CPSC staff uses the CDC Anthropometric Reference, rather than the CDC Growth Chart, because it is more recently collected data and because the data are aggregated by year of age, allowing for estimates by year. CDC growth charts are available at: [https://www.cdc.gov/growthcharts/clinical\\_charts.htm](https://www.cdc.gov/growthcharts/clinical_charts.htm).

months to 17 years old). The weighted average of children's estimated weight in nonfatal NEISS incidents was 40.26 pounds.<sup>37</sup>

Overall, the weighted average of children's reported weight for CPSRMS incidents is 34.23 pounds; whereas, the weighted average of children's estimated weight was 38.8 pounds.

The weight of a child is particularly relevant for climbing incidents because weight is a factor in determining the force a child generates when climbing. For this reason, CPSC staff looked at the weights of children involved in climbing incidents, specifically. Of the 35 fatal CPSRMS child climbing incidents, the weight of the child was reported for 23 incidents, and ranged from 21.5 to 45 pounds. For the remaining 12 climbing incidents in which the child's weight was not reported, CPSC staff estimated their weights, based on age, and the weights ranged from 23.8 to 39 pounds. Of the 32 nonfatal CPSRMS child climbing incidents, the weight of the child was reported in 8 incidents, and ranged from 26 to 80 pounds. For the remaining 24 incidents, staff estimated the weights based on age, and the weights ranged from 25.2 to 45.1 pounds. Weight was not reported in the nonfatal NEISS data, however, using the ages of the children in the 412 nonfatal NEISS child climbing incidents (9 months to 13 years old), staff estimates that their weights ranged from 19.6 to 122 pounds, and the weighted average was 34.2 pounds.

## 5. Televisions

Of the 104 child fatalities involving a CSU and television tipping over, 85 (90 percent) involved a box or cathode ray tube (CRT) television, 2 involved a flat-panel television, and 16 did not provide information about the television. Of the incidents that provided information about television size, the most common television size was 27 inches. The approximate weight range of the CRT televisions, when provided, was between 70 pounds and 150 pounds.

Although televisions are involved in CSU tip overs, and the Commission raised the possibility of addressing televisions in the ANPR, the proposed rule does not focus on television involvement. This is primarily because, in recent years, there has been a decline in the overall number of CSU tip-over incidents that appears to be driven by a decrease in tip overs involving

televisions, while the rate of ED-treated incidents involving CSUs without televisions has remained stable.

## V. Relevant Existing Standards<sup>38</sup>

In the United States, the primary voluntary standard that addresses CSU stability is ASTM F2057–19, *Standard Consumer Safety Specification for Clothing Storage Units*. In addition, CPSC staff identified three international consumer safety standards and one domestic standard that are relevant to CSUs:

- AS/NZS 4935: 2009, the Australian/New Zealand Standard for *Domestic furniture—Freestanding chests of drawers, wardrobes and bookshelves/bookcases—determination of stability*;
- ISO 7171 (2019), the International Organization for Standardization *International Standard for Furniture—Storage Units—Determination of stability*;
- EN14749 (2016), the European Standard, *European Standard for Domestic and kitchen storage units and worktops—Safety requirements and test methods*; and
- ANSI/SOHO S6.5–2008 (R2013), *Small Office/Home Office Furniture—Tests American National Standard for Office Furnishings*.

This section describes these standards and provides CPSC staff's assessment of their adequacy to address CSU tip-over injuries and deaths.

### A. ASTM F2057–19

ASTM first approved and published ASTM F2057 in 2000, and has since revised the standard seven times. The current version, ASTM F2057–19, was approved on August 1, 2019, and published in August 2019. ASTM Subcommittee F15.42, Furniture Safety, is responsible for this standard. Since the first publication of ASTM F2057, CPSC staff has participated in the F15.42 subcommittee and task group meetings and worked with ASTM to improve the standards; however, ASTM has not addressed several issues CPSC has identified.

#### 1. Scope

ASTM F2057–19 is intended to reduce child injuries and deaths from hazards associated with CSUs tipping over and aims “to cover children up to and including age five.” The standard covers CSUs that are 27 inches or more in height, freestanding, and defines CSUs as: “furniture item[s] with drawers and/or hinged doors intended

for the storage of clothing typical with bedroom furniture.” Examples of CSUs provided in the standard include: Chests, chests of drawers, drawer chests, armoires, chifforobes, bureaus, door chests, and dressers. The standard does not cover “shelving units, such as bookcases or entertainment furniture, office furniture, dining room furniture, underbed drawer storage units, occasional/accent furniture not intended for bedroom use, laundry storage/sorting units, nightstands, or built-in units intended to be permanently attached to the building, nor does it cover ‘Clothing Storage Chests’ as defined in Consumer Safety Specification F2598.”

#### 2. Stability Requirements

ASTM F2057–19 includes two performance requirements for stability. The first is in section 7.1 of the standard, *Stability of Unloaded Unit*. This test consists of placing an empty CSU on a hard, level, flat surface, opening all doors (if any) to 90 degrees, and extending all drawers and pull-out shelves to the outstop (which is a feature that limits outward motion of drawers or pull-out shelves). In the absence of an outstop, all drawers and pull-out shelves are opened to two-thirds of the operational sliding length (which is the length from the inside face of the drawer back to the inside face of the drawer). All flaps and drop fronts are opened to their horizontal position or as near to horizontal as possible. If the CSU tips over in this configuration, or is supported by any component that was not specifically designed for that purpose, it does not meet the requirement.

The second stability requirement is in section 7.2 of the standard, *Stability with Load*. This test consists of placing an empty CSU on a hard, level, flat surface, and gradually applying a 50±2-pound test weight. The 50-pound test weight is intended to represent the weight of a 5-year-old child. For units with drawers, the test requires opening one drawer to the outstop, or in the absence of an outstop, to two-thirds of its operational sliding length, and gradually applying the test weight to the front face of the drawer. For units with doors, the test requires opening one door to 90 degrees and gradually applying the test weight. All other drawers and doors remain closed, unless they must be opened to access other components behind them (e.g., a drawer behind a door). Each drawer and door is tested individually. If the CSU tips over in this configuration, or is supported by any component that was not specifically designed for that

<sup>37</sup> Weighted average is equal to the sum of the product of the number of reported incidents for that age times the estimated weight for that age divided by the total number of reported incidents.

<sup>38</sup> For additional information about relevant existing standards, see Tab C, Tab D, Tab F, and Tab N of the NPR briefing package.

purpose, it does not meet this requirement.

### 3. Tip Restraint Requirements

ASTM F2057–19 requires CSUs to include a tip restraint that complies with ASTM F3096–14, *Standard Performance Specification for Tipover Restraint(s) Used with Clothing Storage Unit(s)*.<sup>39</sup> ASTM F2057–19 and F3096–14 define a tip restraint as a “supplemental device that aids in the prevention of tip over.” ASTM F3096–14 provides a test protocol to assess the strength of tip restraints, but does not evaluate the attachment to the wall or CSU. The test method specifies that the tester attach the tip restraint to a fixed structure and apply a 50-pound static load.

### 4. Labeling Requirements

ASTM F2057–19 requires CSUs to be permanently marked in a conspicuous location with warnings that meet specified content and formatting. The warning statements address the risk of children dying from furniture tip overs; not allowing children to stand, climb, or hang on CSUs; not opening more than one drawer at a time; placing the heaviest items in the bottom drawer; and installing tip restraints. For CSUs that are not intended to hold a television, this is also addressed in the warning. Additionally, units with interlock systems must include a warning not to defeat or remove the interlock system. An interlock system is a device that prevents simultaneous opening of more drawers than intended by the manufacturer (like is common on file cabinets). The standard requires that labels be formatted in accordance with ANSI Z535.4, *American National Standard for Product Safety Signs and Labels*.

The standard also includes a performance requirement and test method for label permanence, which are consistent with requirements in other ASTM juvenile furniture product standards. The warning must be “in a conspicuous location when in use” and the back of the unit is not considered conspicuous; the standard does not define “conspicuous location when in use.”

### 5. Assessment of Adequacy

CPSC does not consider the stability requirements in ASTM F2057–19 adequate to address the CSU tip-over hazard because they do not account for multiple open and filled drawers, carpeted flooring, and dynamic forces

generated by children’s interactions with the CSU, such as climbing or pulling on the top drawer. As discussed earlier in this preamble, these factors are commonly involved in CSU tip-over incidents; and, as discussed later in this preamble, testing indicates that these factors decrease the stability of CSUs.

Although ASTM F2057–19 includes a test with all drawers/doors open, the unit is empty and no additional force is applied during this test. Consumers are likely to fill drawers with clothing, since that is the intended purpose of the product, and a CSU with filled drawers is likely to be less stable than an empty unit when more than half of the drawers are open. In addition, although ASTM F2057–19 includes a static weight applied to the top of one open drawer or door (intended to represent a 5-year-old child), this 50-pound weight does not include the additional moment<sup>40</sup> due to the center of gravity of a child climbing, dynamic forces, and horizontal forces when a child climbs, even when only considering the forces generated by very young children. As the UMTRI study described in this preamble found, the forces children can exert while climbing a CSU exceed their static weights. Finally, the testing does not account for the effect of carpeting, which is common flooring in homes (particularly in bedrooms), is commonly present in tip-over incidents, and decreases CSU stability. Thus, by testing CSUs with open drawers empty, a 50-pound static weight, and on a hard, level, flat surface, ASTM F2057–19 does not reflect real-world use conditions that decrease the stability of CSUs.

Staff also looked at whether CSUs involved in tip-over incidents complied with ASTM F2057–19 because it would give an indication of whether F2057 is effective at preventing tip overs and, by extension, whether it is adequate. Of the 89 fatal CPSRMS tip-over incidents involving children and only CSUs, CPSC staff determined that 1 of the CSUs complied with the ASTM F2057–19 stability requirements, 1 CSU met the stability requirements when a test weight at the lower permissible weight range was used, and 11 units did not meet the stability requirements. For the remaining 76 units, staff was unable to determine whether they met the ASTM F2057–19 stability requirements, although staff did determine that an exemplar of one of these CSUs complied with the requirements. Of 263 nonfatal CPSRMS incidents involving children and CSUs without televisions for which

staff assessed the compliance of the CSU, staff determined that 20 met the ASTM F2057–19 stability requirements, and 95 did not. For the remaining 148 units, staff was unable to determine whether the units met the ASTM F2057–19 stability requirements.<sup>41</sup>

Based on a limited review of the tip restraint requirements in ASTM F2057–19 and ASTM F3096–14, CPSC is concerned that these requirements may not be adequate either. ASTM F3096–14 does not address the whole tip-restraint system, which includes the connection to the CSU and the connection to the wall. The standard assumes an ideal connection to both the furniture and the wall, but incidents suggest that both of these are potential points of failure. In addition, ASTM F3096–14 uses a 50-pound static force. Based on the UMTRI study, this force may not represent the force on a tip restraint from child interactions, especially for interactions that can generate large amounts of force, including from older children. For example, the UMTRI study found that when a child bounced, leaned, or yanked on a CSU, the forces generated were equivalent to 2.7, 2.7, and 3.9 times the child’s body weight, respectively, at a distance of 1 foot from the fulcrum. However, staff did not evaluate the tip restraint requirements in ASTM F2057–19 and ASTM F3096–14 because, as discussed in this preamble, several research studies show that a large number of consumers do not anchor furniture, including CSUs, and there are several barriers to the use of tip restraints. As such, even if tip restraint requirements were effective, CSUs should be inherently stable to account for the lack of consumer use of tip restraints and additional barriers to proper installation and use of tip restraints.

CPSC also has some concerns with the effectiveness of the content in the warning labels required in ASTM F2057–19. For example, the meaning of “tipover restraint” may not be clear to consumers, and directing consumers not to open more than one drawer at a time is not consistent with consumer use. In addition, focus group testing discussed in this preamble indicated that consumers had trouble understanding the child climbing symbol required by the standard. CPSC staff also believes that greater clarity about the required placement of the label would make the warning more effective.

<sup>41</sup> Staff did not assess whether NEISS incidents involved ASTM-compliant CSUs because the reports do not contain specific information about the products.

<sup>39</sup> Approved October 1, 2014 and published October 2014.

<sup>40</sup> Moment, or torque, is an engineering term to describe rotational force acting about a pivot point, or fulcrum.

## 6. Compliance With ASTM F2057

CPSC staff assessed compliance with the stability requirements in ASTM F2057–19. In 2016,<sup>42</sup> staff tested 61 CSU samples and found that 50 percent (31 of 61) did not comply with the stability requirements in ASTM F2057.<sup>43</sup> In 2018, CPSC staff assessed a total of 188 CSUs, including 167 CSUs selected from among the best sellers from major retailers, using a random number generator; 4 CSU models that were involved in incidents;<sup>44</sup> and 17 units assessed as part of previous test data provided to CPSC.<sup>45</sup> Of the 188 CSUs, 171 (91 percent) complied with the stability requirements in ASTM F2057. One CSU (0.5 percent) did not comply with the Stability of Unloaded Unit test, and 17 (9 percent) did not meet the Stability with Load test. The unit that did not meet the requirements of the Stability of Unloaded Unit test also did not meet the requirements of the Stability with Load test.

In addition, as part of staff's incident recreation and modeling (discussed in section VII.D. Incident Recreation and Modeling of this preamble), staff determined that two of the seven tested CSU models that had been involved in tip-over incidents complied with the stability requirements in ASTM F2057, and one additional CSU was borderline on whether it complied with the standard. This suggests that the stability requirements in ASTM F2057–19 do not adequately reduce the risk of tip overs.

### B. AS/NZS 4935: 2009

AS/NZS 4935 is a voluntary standard prepared by Standards Australia's and Standards New Zealand's Joint Technical Committee CS–088/CS–091, Commercial/Domestic Furniture. There is only one version of the standard, the current version AS/NZA 4935:2009, which was approved on behalf of the Council of Standards Australia on August 28, 2009, and on behalf of the Council of Standards New Zealand on

<sup>42</sup> Although this testing involved ASTM F2057–14, the stability requirements were the same as in ASTM F2057–19. The test results are available at: [https://www.cpsc.gov/s3fs-public/2016-Tipover-Briefing-Package-Test-Results-Update-August-16-2017.pdf?yMCHvzY\\_YtOZmBAAj0Gjih1IXE7vuu9K](https://www.cpsc.gov/s3fs-public/2016-Tipover-Briefing-Package-Test-Results-Update-August-16-2017.pdf?yMCHvzY_YtOZmBAAj0Gjih1IXE7vuu9K).

<sup>43</sup> This testing also found that 91 percent of CSUs (56 of 61) did not comply with the labeling requirements in ASTM F2057–14, and 43 percent (26 of 61) did not comply with the tip restraint requirements.

<sup>44</sup> Staff tested exemplar units, meaning the model of CSU involved in the incident, but not the actual unit involved in the incident.

<sup>45</sup> The CSUs were identified from the Consumer Reports study "Furniture Tip-Overs: A Hidden Hazard in Your Home" (Mar. 22, 2018), available at: <https://www.consumerreports.org/furniture/furniture-tip-overs-hidden-hazard-in-your-home/>.

October 23, 2009. It was published on November 17, 2009.

### 1. Scope

AS/NZS 4935 aims to address furniture tip-over hazards to children. It describes test methods for determining the stability of domestic freestanding chests of drawers over 500 mm (19.7 inch) high, freestanding wardrobes over 500 mm high (19.7 inch), and freestanding bookshelves/bookcases over 600 mm (23.6 inch) high. It defines "chest of drawers" as containing one or more drawers or other extendible elements and intended for the storage of clothing, and may have one or more doors or shelves. It defines "wardrobe" as a furniture item primarily intended for hanging clothing that may also have one or more drawers, doors or other extendible elements, or fixed shelves. It defines bookshelves and bookcases as sets of shelves primarily intended for storing books, and may contain doors, drawers or other extendible elements.

### 2. Stability Requirements

Similar to ASTM F2057–19, AS/NZS 4935 includes two stability requirements. The first requires the unit, when empty, to not tip over when a 29-kilogram (64-pound) test weight is applied to a single open drawer. The 64-pound test weight is based on the 95th percentile body mass of a 5-year-and-11-month-old child (which is 27 kilograms or 59.5 pounds), adjusted to reflect trends of increasing body mass. The test weight is applied to the top face of a drawer, with the drawer opened to two-thirds of its full extension length. The second test requires the unit not tip over when all of the extension elements are open and the unit is empty. Each drawer or extendible element is open to two-thirds of its extension length, and doors are open perpendicular to the furniture. Units do not pass the stability requirements if they cannot support the test weight, if they tip over, or if they are only prevented from tipping by an extendible element.

### 3. Tip Restraint Requirements

The standard does not require, but recommends, that tip restraints be included with units, along with attachment instructions.

### 4. Labeling Requirements

The standard requires a warning label, and provides example text that addresses the tip-over hazard. The standard also requires a warning tag with specific text and formatting. The label and tag include statements informing consumers about the hazard, warning of tip overs and resulting

injuries, and indicating how to avoid the hazard. These requirements do not address the use of televisions. The standard includes label permanency requirements and mandates that the warning label be placed "inside of a top drawer within clear view when the drawer is empty and partially opened, or on the inside face of a drawer" for chests of drawers and wardrobes.

### 5. Assessment of Adequacy

CPSC does not consider the stability requirements in AS/NZS 4935 adequate to address the CSU tip-over hazard because they do not account for multiple open and filled drawers, carpeted flooring, and dynamic forces generated by children's interactions with the CSU, such as climbing or pulling on the top drawer. As discussed in this preamble, these factors are commonly involved in CSU tip-over incidents and testing indicates that they decrease the stability of CSUs.

AS/NZS 4935 requires drawer extension to only two-thirds of extension length for both stability tests. This partial extension does not represent real-world use because children are able to open drawers fully, incidents involve fully open drawers, and opening a drawer further decreases the stability of a CSU. In addition, it does not account for filled drawers, which are expected during real-world use, are common in tip-over incidents, and contribute to instability when multiple drawers are open. It also does not account for carpeted floors, which are common in incidents and contribute to instability. Although AS/NZS 4935 uses a heavier test weight than ASTM F2057–19, it is inadequate because neither stability test accounts for the moments children can exert on CSUs during interactions, such as climbing. Considering additional moments, the 64 pounds of weight on the drawer face is equivalent to a 40-pound child climbing the extended drawer. A 40-pound weight corresponds to a 75th percentile 3-year-old child, 50th percentile 4-year-old child, and 25th percentile 5-year-old child.<sup>46</sup>

### C. ISO 7171 (2019)

The International Organization for Standardization (ISO) developed the voluntary standard ISO 7171 through the Technical Committee ISO/TC 136, *Furniture* and published the first version in May 1988. The current 2019

<sup>46</sup> Fryar, C.D., Carroll, M.D., Gu, Q., Afful, J., Ogden, C.L. (2021). Anthropometric reference data for children and adults: United States, 2015–2018. National Center for Health Statistics. Vital Health Stat 3(46).

version was published in February 2019.

### 1. Scope

ISO 7171 (2019) describes methods for determining the stability of freestanding storage furniture, including bookcases, wardrobes, and cabinets, but the standard does not define these terms.

### 2. Stability Requirements

ISO 7171 (2019) includes three stability tests, all of which occur on a level test surface. The first uses a weight/load on an open drawer. The second involves all drawers being filled and a load/weight placed on a single open drawer. In the loaded test, one drawer is opened to the outstop, and if no outstops exist, the drawer is opened to two-thirds of its full extension length. The test weight is applied to the top face of the opened drawer, and varies depending on the height of the unit (either 200 N (44 pounds) or 250 N (55 pounds)). The fill weight is also variable, depending on the clearance height and volume of the drawer (fill density ranges from 6.25 lb/ft<sup>3</sup> to 12.5 lb/ft<sup>3</sup>). The third test is an unloaded test with all drawers open. For this test, drawers and extendible elements are open to the outstop and doors are open 90 degrees. If there are no outstops, then the extension elements are open to two-thirds of their extension length. Existing interlock systems are not bypassed for this test.

ISO 7171 (2019) does not include criteria for determining whether a unit passed or failed the loaded stability test. However, it includes a table of “suggested” forces, depending on the height of the unit.

An additional unfilled, closed drawer test is required for units greater than 1000 mm in height, where a vertical force of 350 N (77 pounds) along with a simultaneous 50 N (11 pounds) outward horizontal force is applied to the top surface of the unit.

### 3. Tip Restraint Requirements

ISO 7171 (2019) does not require tip restraints to be provided with units, but does specify a test method for them. The tip restraints are installed in both the wall and unit during the test and a 300 N (67.4 lbf) horizontal force is applied in the direction most likely to overturn the unit. The force is maintained between 10 and 15 seconds.

### 4. Labeling Requirements

The standard does not have any requirements or test methods related to warning labels.

### 5. Assessment of Adequacy

CPSC does not consider the stability requirements in ISO 7171 (2019) adequate to address the CSU tip-over hazard because they do not account for carpeted flooring, or dynamic and horizontal forces generated by children’s interactions with the CSU, such as climbing or pulling on the top drawer. In addition, although ISO 7171 (2019) includes a stability test with filled drawers, the multiple open drawer test does not include filled drawers, and the simultaneous conditions of multiple open and filled drawers during a child interaction are not tested. As discussed in this preamble, these factors are commonly involved in CSU tip-over incidents and testing indicates that they decrease the stability of CSUs. Finally, test weights are provided only as recommendations and there are no criteria for determining whether a unit passes.

#### D. EN 14749: 2016

EN 14749: 2016 is a European Standard that was prepared by Technical Committee CEN/TC 207 “Furniture.” This standard was approved by the European Committee for Standardization (CEN) on November 21, 2015, and supersedes EN 14749:2005, which was approved on July 8, 2005, as the original version. EN 14749:2016 is a mandatory standard and applies to all CEN members.

### 1. Scope

EN 14749: 2016 describes methods for determining the stability of domestic and non-domestic furniture with a height  $\geq$  600 mm (23.6 in) and a potential energy, based on mass and height, exceeding 60 N-m (44.25 ft-lbs). Kitchen worktops and television furniture are the only furniture types defined. The test methods in this standard are taken from EN 16122: 2012, *Domestic and non-domestic storage furniture-test methods for the determination of strength, durability and stability*, which covers “all types of domestic and non-domestic storage furniture including domestic kitchen furniture.”

### 2. Stability Requirements

EN 14749: 2016 includes three stability tests, which are conducted with the units freestanding. In the first loaded test, a 75 N (16.9 lbf) test weight is applied to the top of the drawer face, when pulled to the outstop. However, if no outstops exist, the extension element is open to two-thirds of its full extension length. In the second test, all drawers and extendible elements are open to the outstop and doors are open

90 degrees. If no outstops are present, then the extension elements are open to two-thirds of their extension lengths. Existing interlock systems are not bypassed for this test. The third test involves filled drawers and a load; all storage areas are filled with weight and the loaded test procedure (above) is carried out but with a test weight that is 20 percent of the mass of the unit, including the drawer fill, not exceeding 300 N (67.4 pounds). Similar to ISO 7171, an additional unfilled, closed drawer test is required for units greater than 1000 mm in height, where a vertical force of 350 N (77 pounds) along with a simultaneous 50 N (11 pounds) outward horizontal force are applied to the top surface of the unit.

Relevant to the portions of stability testing that involve opening drawers, the standard also accounts for interlock systems, requiring one extension element to be open to its outstop, or in the absence of an outstop, two-thirds of its operational sliding length, and a 100 N (22 lbf) horizontal force to be applied to the face of all other extension elements. This is repeated 10 times on each extension element and all combinations of extension elements are tested.

### 3. Tip Restraint Requirements

EN 14749: 2016 does not include any requirements regarding tip restraints.

### 4. Labeling Requirements

EN 14749: 2016 does not include any requirements regarding warning labels.

### 5. Assessment of Adequacy

CPSC does not consider the stability requirements in EN 14749: 2016 adequate to address the CSU tip-over hazard because they do not account for carpeted flooring, or dynamic and horizontal forces generated by children’s interactions with the CSU, such as climbing or pulling on the top drawer. In addition, although the standard includes a stability test with filled drawers, the multiple open drawer test does not include filled drawers, and the simultaneous conditions of multiple open and filled drawers during a child interaction are not tested. Moreover, the fill weight ranges from 6.25 lb/ft<sup>3</sup> to 12.5 lb/ft<sup>3</sup>, which includes fill weights lower than staff identified for drawers filled with clothing (discussed in section VII.A. Multiple Open and Filled Drawers of this preamble). As discussed in this preamble, these factors are commonly involved in CSU tip-over incidents and testing indicates that they effect the stability of CSUs.



*E. ANSI/BIFMA SOHO S6.5–2008 (R2013)*

ANSI/SOHO S6.5 does not address CSUs, but rather, applies to office furniture, such as file cabinets. However, CPSC considered this standard because it addresses interlock systems, which some CSUs include and are relevant to stability testing. This standard was completed by BIFMA Engineering Committee and its subcommittee on Small Office/Home Office Products in 2000. The first version was approved by ANSI on August 4, 2008. The current version of the standard was approved on September 17, 2013.

This standard specifies tests for “evaluating the safety, durability, and structural adequacy of storage and desk-type furniture intended for use in the small office and/or home office.” ANSI/BIFMA SOHO S6.5 includes testing to evaluate interlock systems. The test procedure calls for one extendable element to be fully extended while a 30 lbf horizontal pull force is applied to all other fully closed extendable elements. Every combination of open/closed extendable elements<sup>47</sup> must be tested. The interlock system must be fully functional at the completion of this test and no extendable element may bypass the interlock system.

As discussed in section VIII.B.2.a.ii Interlocks of this preamble, child strength studies show that children between 2 and 5 years old can achieve a mean pull force of 17.2 pounds. Therefore, CPSC considers a 30-pound horizontal pull force adequate to evaluate the strength of an interlock system. However, because ANSI/SOHO S6.5 does not include stability tests or requirements reflecting the real-world factors involved in CSU tip overs, the standard would not adequately address the CSU tip-over hazard.

## VI. Technical Background

This preamble and the NPR briefing package include technical discussions of engineering concepts, such as center of gravity (also referred to as center of mass), moments, and fulcrums. Tab D of the NPR briefing package provides detailed background information on each of these terms, including how staff applies them to CSU tip-over analysis. This section provides a brief overview of that information; for further

information, see Tab D of the NPR briefing package.

### A. Center of Gravity and Center of Mass

Center of Gravity (CG) or Center of Mass (CM)<sup>48</sup> is a single point in an object, about which its weight (or mass) is completely balanced. In terms of freestanding CSU stability, if the CSU’s CG is located behind the front foot, the CSU is stable and will not tip over on its own. Alternatively, if the CSU’s CG is in front of the front foot, the CSU is unstable and will tip over. The CG (and CM) of an object is dependent on its geometry and materials. For example, CSU drawers typically have a front that is thicker and larger than the back, which causes the drawer’s CG to be closer to the front. The CSU’s CG is defined by the position and weight of the CSU cabinet (without drawers), combined with the position and weight of each drawer. A CSU’s CG is equal to the sum of the products of the position and the weight of each component, divided by the total weight.

The CG of a CSU will change as a result of the position of the drawers, doors, and pull-out shelves (open or closed). Opening extendable elements, such as drawers, shifts the CG towards the front of the CSU. The closer the CG is to the front leg, the easier it is to tip forward if a force is applied to the drawer. Therefore, CSUs will tip more easily as more drawers are opened. The CG of a CSU will also change depending on the position and amount of clothing in each drawer. Closed drawers filled with clothing tend to stabilize a CSU, but as each filled drawer is pulled out, the CSU’s CG will shift further towards the front.

### B. Moment and Fulcrum

Moment, or torque, is an engineering term to describe rotational force acting about a pivot point, or fulcrum. The moment is created by a force or forces acting at a distance, or moment arm, away from a fulcrum. One simple example is the moment or torque created by a wrench turning a nut. The moment or torque about the nut is due to the perpendicular force on the end of the wrench applied at a distance (moment arm) from the fulcrum (nut). Likewise, a downward force on an open CSU drawer creates a moment about the fulcrum (front leg) of the CSU. A CSU will tip over about the fulcrum due to

a force (e.g., weight of a child positioned over the front of a drawer) and the moment arm (e.g., extended drawer).

Downward force or weight applied to the drawer tends to tip the CSU forward around the fulcrum at the base of the unit, while the weight of the CSU opposes this rotation. The CSU’s weight can be modeled as concentrated at a single point: The CSU’s CG. The CSU’s stability moment is created by its weight, multiplied by the horizontal distance of its CG from the fulcrum. A child can produce a moment opposing the weight of the CSU, by pushing down or sitting in an open drawer. This moment is created by the vertical force of the child, multiplied by the horizontal distance to the fulcrum. The CSU becomes unbalanced and tips over when the moments applied at the front of the CSU exceed the CSU’s stability moment.

Horizontal forces applied to pull on a drawer also tend to tip the CSU forward around the front leg (pivot point or fulcrum) at the base of the unit, while the weight of the CSU opposes this rotation. In this case, the moment produced by the child is the horizontal pull force transmitted to the CSU (for example, through a drawer stop), multiplied by the vertical distance to the fulcrum. The CSU becomes unbalanced and tips over when the moments applied at the front of the CSU exceed the CSU’s stability moment.

When a child climbs a CSU, both horizontal forces and vertical forces acting at the hands and feet contribute to CSU tip over. Figure 1 shows a typical combination of forces acting on a CSU while a child is climbing, and it describes how those forces contribute to a tip-over moment. Note that when the horizontal force at the hands and feet are approximately equal, which will occur when the child’s CM is balanced in front of the drawers, the height of the bottom drawer becomes irrelevant when determining the tip-over moment. In this case, only the height of the hands above the feet matters. As Figure 1 shows, a child climbing on drawers opened distance A1 from the fulcrum, with feet at height B1 from the ground and hands at height B2 above the feet, will act on the CSU with horizontal forces  $F_H$  and vertical forces  $F_V$ . The CSU’s weight at a distance A2 from the CSU’s front edge touching the ground creates a stabilizing moment. The CSU will tip if Moment 1 is greater than Moment 2.

<sup>47</sup> Excluding doors, writing shelves, equipment surfaces, and keyboard surfaces.

<sup>48</sup> For CSU-sized objects, CG and CM are effectively the same. Therefore, CG and CM are used interchangeably in this preamble.

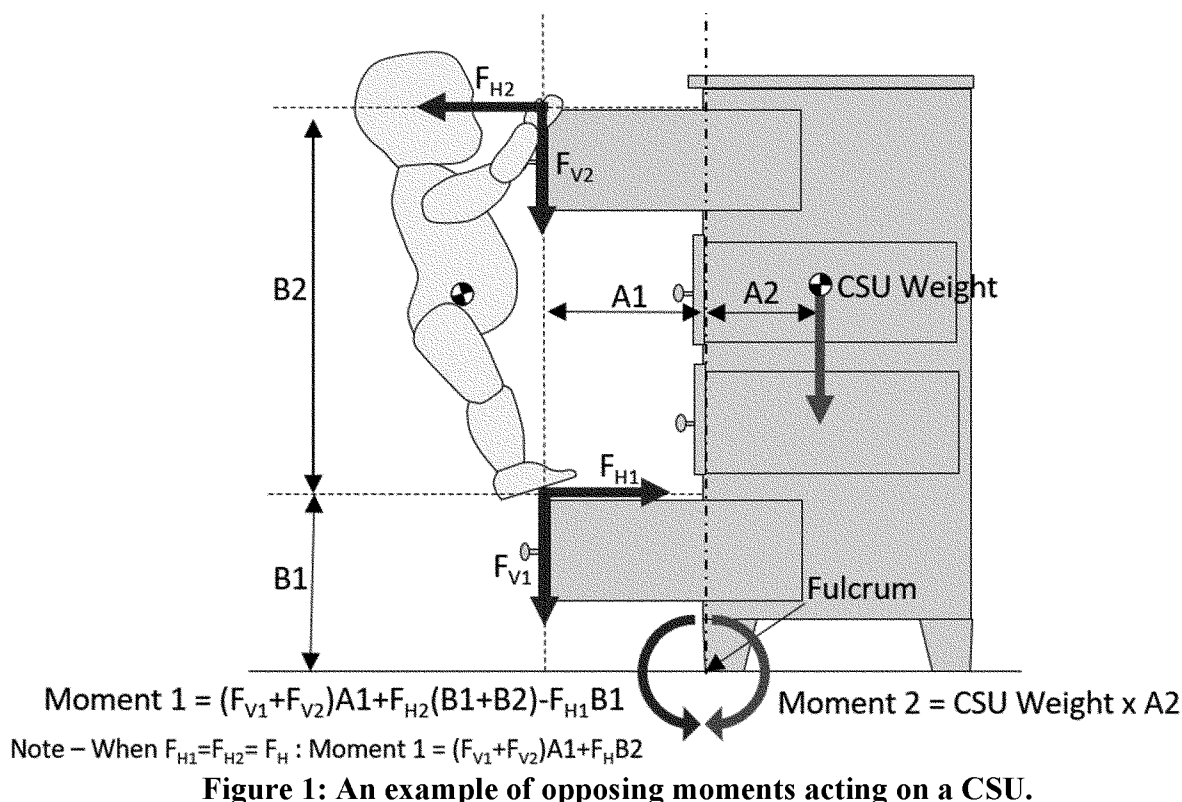

## VII. Technical Analysis Supporting the Proposed Rule

In addition to reviewing incident data, CPSC staff conducted testing and analysis, analyzed tip-over incidents, and commissioned several contractor studies to further examine factors relevant to CSU tip overs. This section describes that testing and analysis.

### A. Multiple Open and Filled Drawers<sup>49</sup>

Staff's technical analysis, as confirmed by testing, indicates that multiple open drawers decrease the stability of a CSU, and filled drawers further decrease stability when more than half of the drawers by volume are open, but increase stability when more than half of the drawers by volume are closed. Thus, while multiple open drawers, alone, can make a unit less stable, whether the drawers are full when open is also a relevant consideration. When filled drawers are closed, the clothing weight contributes to the stability of the CSU, because the clothing weight is behind the front legs (fulcrum). However, open drawers contribute to the CSU being less stable, because the clothing weight is shifted forward in front of the front legs (fulcrum).

<sup>49</sup> Further details about the effect of open and filled drawers on CSU stability is available in Tab D, Tab L, and Tab O of the NPR briefing package.

To assess the effect of open drawers and filled drawers on CSU stability, CPSC staff conducted testing to evaluate the effect of various combinations of open/closed and filled/empty drawers using a convenience sample of CSUs.<sup>50</sup> Staff conducted two phases of testing (Phase I and Phase II). The purpose of the testing was to assess the weight at which a CSU became unstable and tipped over with various configurations of drawers open/closed and filled/empty.

The primary variable of interest in the Phase I study was the influence of multiple open/closed drawers. The 11 CSUs tested in Phase I were primarily units with a single column of drawers. The Phase II study examined the influence of multiple open/closed drawers and filled/empty drawers. The 15 CSUs tested in Phase II included more complex units with multiple columns of drawers. Staff used the stability test methods in ASTM F2057–19, with some alterations, to collect information about variables that ASTM F2057–19 does not address (*i.e.*, the effect of open/closed drawers, filled/empty drawers, and tip weight). Filled drawers contained weight bags to simulate a drawer filled with clothing, based on the interior volume of the

<sup>50</sup> Because of the limited number of units tested, this study provides useful information, but the results are limited to the tested units.

drawer and 8.5 pounds per cubic foot (the explanation for this fill volume is provided below). In addition to various configurations of open/closed and filled/empty drawers, staff also varied the drawer on which the tip weight mechanism was applied, referred to as the “tip weight application location.”

The primary goal of the Phase I study was to gain insight into the influence of multiple open or closed drawers on CSU stability as a function of tip weight. Additionally, this study was designed to test and ideally confirm that identical drawer open/closed patterns (*e.g.*, two open drawers) yielded nearly identical tip weights, particularly when drawers were identical in size, regardless of the specific configuration (drawers open/closed and tip weight application location). The Phase I study confirmed that comparable tip weights existed for similar open/closed drawer configurations in the tested CSUs when considering a simple single column of drawers that are identically sized.

The primary goal of the Phase II study was to examine additional complexities with respect to real-world scenarios of CSUs. This included more complex CSUs and combinations of filled and/or empty drawers (including partially filled configurations, in which some drawers were filled and some were empty) within the same CSU, in addition to open/closed drawers. Staff also modified the test method to decrease

test-to-test variability, for example, by adding cross hatches on the drawer and the weight bag to ensure weight bags were centered within drawers.

Based on this testing, lighter and shorter units appear to be less stable, although a taller and heavier unit was also unstable; and similar units passed and failed ASTM's stability requirements. This suggests that specific heights or weights of a CSU do not correlate with stability or instability. Similarly, the footprint ratio (depth-to-width ratio) of the CSU, alone, did not appear to affect tip weight.

From the 26 CSUs tested, CPSC staff analyzed 1,777 data points for a variety of combinations (filled/empty drawers, open/closed drawers, and tip weight application location),<sup>51</sup> and supplemented this data with results from other CSU testing CPSC staff had performed. The results of this testing indicated that individual CSUs vary in stability, depending on the configuration of open/closed drawers, and filled/empty drawers, and that different CSU drawer structures (e.g., number of columns, relative drawer

sizes) have an influence on tip weight. In general, the results indicated that CSUs were less stable as more drawers were opened, and that filled drawers have a variable effect on stability. A filled closed drawer contributes to stability, while a filled open drawer decreases stability. Depending on the percent of drawers that are open and filled, having multiple drawers open decreased the stability of the CSU.

To determine the appropriate method for simulating CSU drawers that are partially filled or fully filled, staff considered previous analyses, and conducted additional testing. Although ASTM F2057–19 does not include filled drawers as part of its stability testing, the ASTM F15.42 subcommittee has considered a “loaded” (filled) drawer requirement and test method. The ASTM task group used an assumed clothing weight of 8.5 pounds per cubic foot in testing and other discussions of filled drawers. Kids in Danger and Shane's Foundation found a similar density (average of 8.9 pounds per cubic foot) when they filled CSU drawers with

boys' t-shirts in a 2016 study on furniture stability.<sup>52</sup>

To assess whether 8.5 pounds per cubic foot reasonably represents the weight of clothing in a drawer, CPSC staff conducted testing. As part of this assessment, staff looked at four drawer fill conditions. Staff considered folded and unfolded clothing with a total weight equal to 8.5 pounds per cubic foot of functional drawer volume in the drawer; and the maximum amount of folded and unfolded clothing that could be put into a drawer that would still allow the drawer to open and close. For these tests, staff used an assortment of boys' clothing in sizes 4, 5, and 6. Staff used a CSU with a range of drawer sizes to assess small, medium, and large drawers; the functional drawer volume of these 3 drawer sizes was 0.76 cubic feet, 1.71 cubic feet, and 2.39 cubic feet, respectively. Staff determined the calculated clothing weight for the 8.5 pounds per cubic foot drawer fill conditions by multiplying 8.5 by the drawer's functional volume, defined as:<sup>53</sup>

$$\text{Functional Volume} = \left\{ [\text{Interior Area}] (ft^2) \left[ \text{Clearance Height} - \frac{1}{8} \right] (in) \left[ \frac{1}{12} \right] \left( \frac{ft}{in} \right) \right\}$$

For all three drawer sizes, staff was able to fit 8.5 pounds per cubic foot of folded and unfolded clothing in the drawers. When the clothing was unfolded, the clothing fully filled the drawers, but still allowed the drawer to close. Because the unfolded clothing was stuffed into the drawer fairly tightly, it was not easy to see and access clothing below the top layer. When the clothing was folded, the clothing also fully filled the drawers and still allowed the drawer to close. The folded clothing was tightly packed, but allowed for additional space when compressed. The maximum unfolded clothing fill weight was 6.52, 14.64, and 21.20 pounds for the three drawer sizes, respectively; and the maximum folded clothing fill weight was 7.72, 16.08, and 22.88 pounds for the three drawer sizes, respectively.

Staff also compared the calculated clothing weight (i.e., using 8.5 pounds per cubic foot), maximum unfolded drawer fill weight, and maximum folded drawer fill weight for each drawer. The maximum unfolded clothing fill weight was slightly higher than the calculated clothing fill weight for all tested

drawers. The difference between the maximum unfolded clothing fill weight and the calculated clothing weight ranged from 0.08 pounds to 0.87 pounds. The maximum unfolded clothing fill weight was 101 to 104 percent of the calculated clothing weight, depending on the drawer. The maximum folded clothing fill weight was higher than both the maximum unfolded clothing fill weight and the calculated clothing fill weight for all tested drawers; however, the differences were relatively small. The difference between the maximum folded clothing fill weight and the calculated clothing weight ranged from 1.28 to 2.55 pounds. The maximum unfolded clothing fill weight was 111 to 120 percent of the calculated clothing weight, depending on the drawer. The maximum unfolded clothing fill density was slightly higher than 8.5 pounds per cubic foot for all tested drawers; and the maximum unfolded clothing fill density ranged from 8.56 to 8.87 pounds per cubic foot, depending on the drawer. The maximum folded clothing fill density was higher than both the maximum

unfolded clothing fill density and 8.5 pounds per cubic foot for all tested drawers. The maximum folded clothing fill density ranged from 9.40 to 10.16 pounds per cubic foot, depending on the drawer. Thus, there does not appear to be a large difference in clothing fill density based on drawer size.

Based on this testing, staff found that 8.5 pounds per cubic foot of clothing will fill a drawer; however, this amount of clothing is less than the absolute maximum amount of clothing that can be put into a drawer, especially if the clothing is folded. The maximum amount of unfolded clothing that could be put into the tested drawers was only slightly higher than 8.5 pounds per cubic foot. Although staff achieved a clothing density as high as 10.16 pounds per cubic foot with folded clothing, consumers may be unlikely to fill a drawer to this level because it requires careful folding, and it is difficult to remove and replace individual pieces of clothing. On balance, staff concluded that 8.5 pounds per cubic foot of functional drawer volume is a reasonable approximation of

<sup>51</sup> Staff excluded some data points for reasons explained in Tab O of the NPR briefing package.

<sup>52</sup> Kids in Danger and Shane's Foundation (2016). Dresser Testing Protocol and Data. Data set provided to CPSC staff by Kids in Danger, January 29, 2021.

<sup>53</sup> “Clearance height” is the height from the interior bottom surface of the drawer to the closest vertical obstruction in the CSU frame. “Functional height” is clearance height minus 1/8 inch.

the weight of clothing in a fully filled drawer.

### *B. Forces and Moments During Child Interactions With CSUs<sup>54</sup>*

As indicated above, some of the common themes that staff identified in CSU tip-over incident data involve children interacting with CSUs, including climbing on them and opening drawers. To determine the forces and other relevant factors that exist during these expected interactions between children and CSUs, CPSC contracted with UMTRI to conduct research. The researchers at UMTRI, in collaboration with CPSC staff, designed a study to collect information about children's measurements and proportions, interest in climbing and climbing behaviors, and the forces and moments children can generate during various interactions with a CSU. Forty children, age 20 months to 65 months old, participated in the study. For additional details about the study, see UMTRI's full report in Tab R of the NPR briefing package.

#### 1. Overview of Interaction Portion of UMTRI Study

The interaction portion of the study included children interacting with a CSU test apparatus with instrumented handles and a simulated drawer and tabletop (to simulate the top of a CSU or other tabletop or furniture unit). Researchers measured the forces of the children acting on the test apparatus and calculated moments generated by the children based on the location of the CSU's front leg tip point (fulcrum). The researchers based the fulcrum's location on a dataset of CSU drawer extensions and heights provided by CPSC staff.<sup>55</sup>

<sup>54</sup> Further information about the study described in this section, and forces and moments generated by children's interactions with CSUs, is available in Tab C, Tab D, and Tab R of the NPR briefing package.

<sup>55</sup> CPSC staff provided UMTRI researchers with a dataset of drawer extensions and drawer heights

The interaction portion of the study looked at forces associated with several climbing-related interactions of interest, which staff and researchers selected based on CSU tip-over incidents, videos of children interacting with CSUs and similar furniture items, and plausible interactions based on children's developmental abilities. Staff focused on the ascent/climbing<sup>56</sup> interaction for this rulemaking because climbing incidents were the most common interaction among fatal CPSRMS incidents and nonfatal NEISS incidents, where the interaction was reported, and they were the second most common interaction in nonfatal CPSRMS incidents, where the interaction was reported; and because climbing begins with ascent, which is a child's initial step to climb up on to the CSU, and therefore, is considered an integral part of all climbing interactions.

#### 2. Test Apparatus and Data Acquisition

UMTRI researchers created the test apparatus shown in Figure 2, which used a padded force plate to measure interactions with the floor and included a column to which the various instrumented test fixtures were

from the ground from a sample of approximately 180 CSUs. The researchers selected the 90th percentile drawer extension (12 inches) and drawer height (16 inches) as the basis for placing the moment fulcrum in most of their analysis.

<sup>56</sup> Ascending is a subcategory of climbing, and is described as a child's initial step to climb up on to a CSU. Therefore, ascending is an integral part of climbing. The UMTRI study provided information about forces children generate during ascent, because that testing measured forces children generate during an initial step onto the CSU test fixture. Those forces can be used to model children climbing because ascent is the first and integral step to climbing, but not all climbing interactions can be modeled with ascent, as forces associated with some other behaviors can exceed those for ascent. The term "climbing" is often used in this preamble and the NPR briefing package because that is the general behavior described in many incidents. Both climbing and ascending are used to refer to the force children generate on a CSU, for purposes of the proposed rule.

attached. Tests were conducted with a pair of handlebars (simulating drawer handles or fronts), a simulated drawer, and a simulated tabletop. In preparation for the study, CPSC staff worked with UMTRI researchers to develop a test fixture that modeled the climbing surfaces of a CSU. CPSC staff provided information to UMTRI researchers on drawer extension and heights from the sample of dressers used in CPSC staff's evaluation (Tab N of the NPR briefing package). Researchers selected and constructed a parallel bar test fixture, representing a lower foothold and an upper handhold. These bars represent a best-case CSU climbing surface, similar to the top of a drawer.

UMTRI researchers configured the test fixtures based on each child's anthropometric measurements. Researchers set the upper bar to three different heights relative to the padded floor surface: Low (50 percent of the child's upward grip reach), mid (75 percent of the child's upward grip reach), and high (100 percent of the child's upward grip reach); researchers set the lower bar to two different heights: Low (4.7 inches from the padded floor surface) and high (the child's maximum step height above the padded floor). The heights for the bars were within plausible heights for CSU drawers. Researchers set the horizontal position of the upper bar to two different positions: "aligned" with the lower bar, or "offset" from the lower bar, at a distance equal to 20 percent of the child's upward grip height. Tabs C and R of the NPR briefing package contain more information about the test fixture configurations. The bars, drawer, and tabletop, as well as the floor in front of the test fixture, had force measurement instrumentation that recorded forces over time in the horizontal (fore-aft, x) and vertical (z) directions.

**BILLING CODE 6355-01-P**

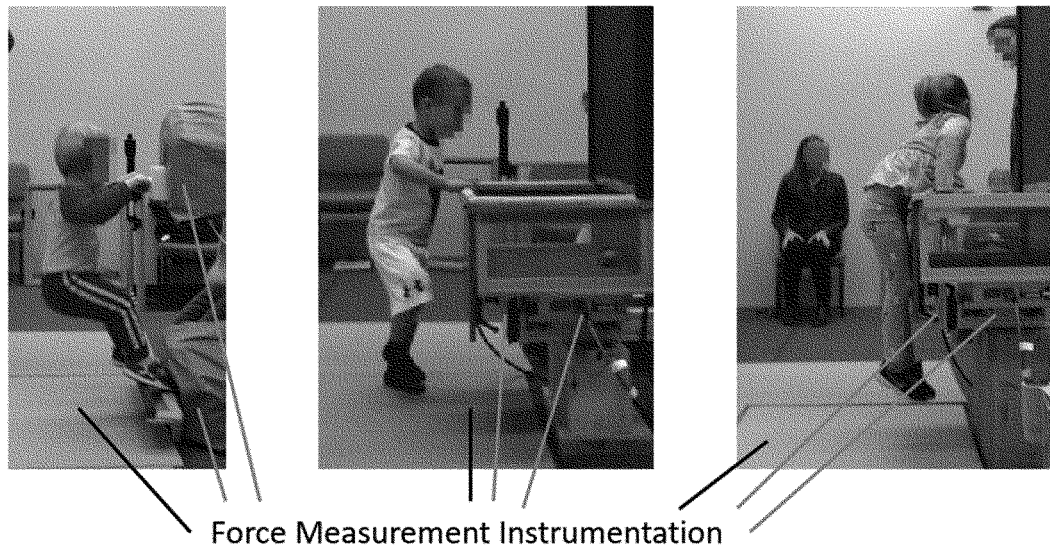

**Figure 2: The test setup and location of instruments used to measure force during handle trials (left), box/drawer trials (center), and table trials (right).**

### 3. Target Behaviors of Children Interacting With a CSU

CPSC staff worked with UMTRI researchers to develop a set of scripted interactions. Staff focused on realistic interactions in which the child's position and/or dynamic interactions were the most likely to cause a CSU to tip over. The interactions were based on incident data and online videos of children interacting with CSUs and other furniture items. The interactions UMTRI researchers evaluated included:

- *Ascend*: Climb up onto the test fixture;
- *Bounce*: Bounce vigorously without leaving the bar;
- *Lean back*: Lean back as far as possible while keeping both hands and feet on the bars;

- *Yank*: From the lean back position, pull on the bar as hard as possible;
- *1 hand & 1 foot*: Take one hand and foot (from the same side of the body) off the bars and then lean as far away from the bars as possible;
- *Hop up*: Hold the upper bar and try to jump from the floor to a position where the arms are straight and the hips are in front of the upper bar, an action similar to hoisting oneself out of a swimming pool;
- *Hang*: Hold onto the upper bar, lift feet off the floor by bending knees, hang still for a few seconds, and then straighten legs to return to the floor;
- *Descend*: Climb down from the test fixture.

As described above, the ascend interaction best models the climbing behavior commonly seen in incidents,

and is analogous to a child's initial step to climb up on to the CSU, which is an integral climbing interaction. The other, more extreme interactions, such as bounce, lean, and yank, were identified as plausible interactions, based on child behavior; but these interactions were not directly observed in the incident data.

After the children performed the interaction, the researchers reviewed video from each trial to isolate and characterize interactions of interest. Interactions of interest for the handle trials were categorized as: Ascent, Bounce, Lean (lean back), Yank, and One Hand (see Figure 3). Researchers analyzed forces from each extracted behavior to identify peak forces and moments.

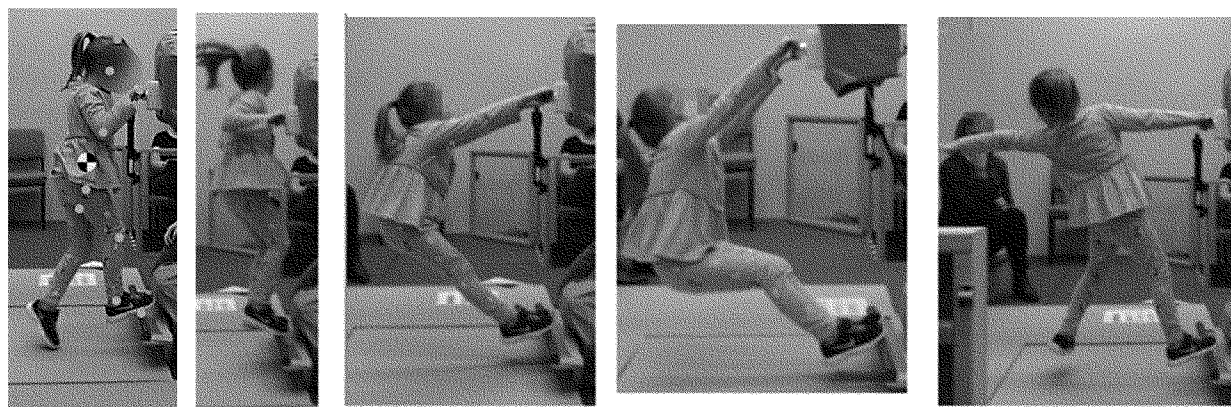

Ascent

Bounce

Lean Back

Yank

One Hand

**Figure 3: Children were instructed to climb on (ascend) the test fixture and perform certain targeted behaviors. The Ascent image on the left also shows markers that were used to find the CM location, discussed in the next section.**

#### 4. Image-Based Posture Analysis

Participant postures have strong effects on the horizontal forces exerted by the child and the subsequent calculated moments, due to the location of the child's CM during each behavior. Thus, the CM of the child is important when evaluating the stability or tip-over

propensity of the child/CSU-combined system. UMTRI researchers used the images of the subjects to estimate the location of the child's CM. The UMTRI researchers extracted video frames at time points of interest (typically when the child produced the maximum moment during the interaction) and

manually digitized the series of landmarks on the image of the child, as shown in Figure 4. The location of the CM was estimated, based on anthropometric information on children,<sup>57</sup> as 33 percent of the distance from the buttock landmark to the top-of-head landmark.

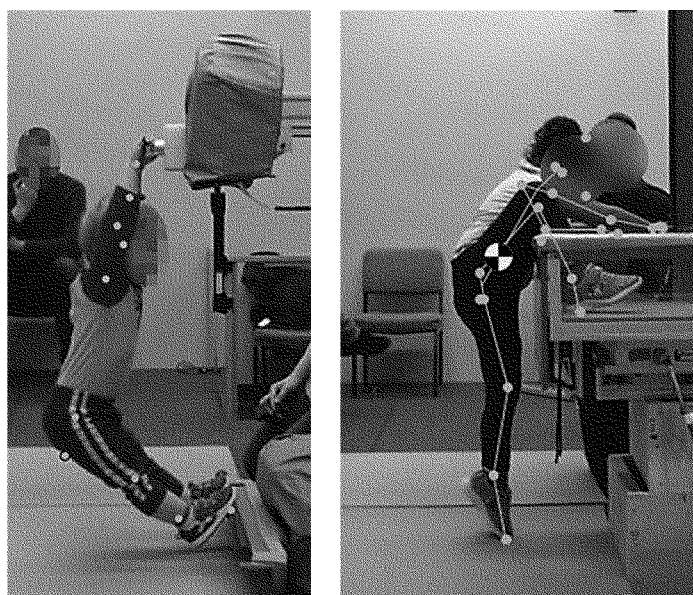

**Figure 4: The photo on the left shows the right side of the body as it is digitized. The photo on the right shows the resulting body segments and the estimated location of the CM for a different child and test condition.**

<sup>57</sup> Snyder, R.G., Schneider, L.W., Owings, C.L., Reynolds, H.M., Golomb, D.H., Schork, M.A.,

Anthropometry of Infants, Children and Youths to Age 18 for Product Safety Design (Report No. UM-

HSRI-77-17), prepared for the U.S. Consumer Product Safety Commission (1977).

The UMTRI researchers estimated the location of the child’s CM by examining the side-view images from the times of

maximum moment, as shown in Figure 5. Table 1 shows the average estimated CM location for each behavior.<sup>58</sup> The

children in the study extended their CM an average of about 6 inches from the handle/foothold while ascending.

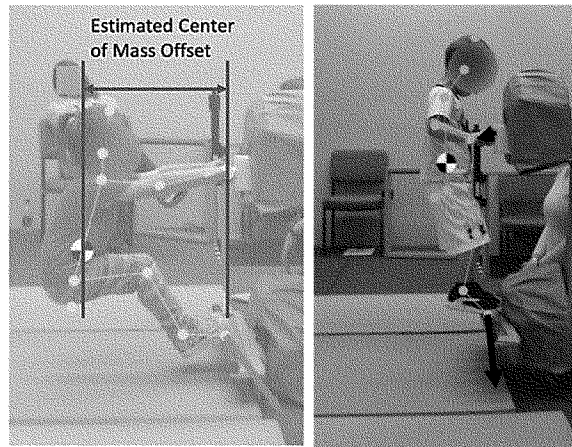

**Figure 5. Example of digitized frame with estimated CM location and offset from upper handle. The lean behavior is shown on the left, and the ascend behavior is shown on the right. Forces at the hands and feet are shown with scaled arrows.**

TABLE 1—ESTIMATED CM HORIZONTAL OFFSET FROM THE HANDLES FOR ALIGNED TRIALS  
[Inches]

Behavior	N subjects	N trials	Mean	SD	10th percentile	50th percentile	90th percentile
Ascent .....	36	109	6.1	2.0	4.3	6.1	8.6
Bounce .....	32	80	6.0	2.5	4.0	5.8	9.1
Lean Back .....	30	81	11.3	3.4	8.5	11.6	15.9
Yank .....	25	53	10.9	3.4	7.3	11.5	15.9

5. Handle Trial Force Results

Figure 6 shows side-view images of examples of children interacting with the handle fixture. The frames were taken at the time of peak tip-over moment. Forces exerted by the child at the hands and feet are illustrated using

scaled vectors (longer lines indicate greater force magnitude; arrow direction indicates force direction). Digitized landmarks and estimated CM locations are shown. The images demonstrate that forces at both the hands and feet often have substantial horizontal components, and usually, but not always, the foot

forces are larger than the hand forces. The horizontal components at the hands and feet are also in opposite directions: The horizontal foot forces are forward (toward the test fixture), while the hand forces are rearward (toward the child).

<sup>58</sup> Graphs are available in Tab R of the NPR briefing package (page 59, Figure 54).

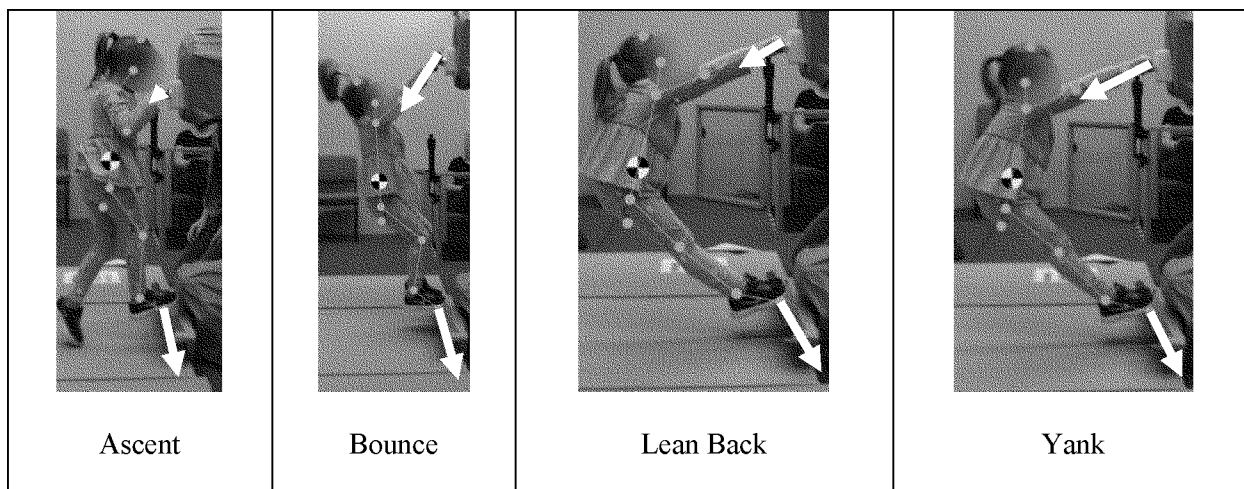

**Figure 6: Depicts examples of interactions. Arrows illustrate the directions and relative magnitudes of forces at the hands and feet.**

Figure 17 in Tab D of the NPR briefing package shows an exemplar time-history plot of the horizontal and vertical forces for the Ascent behavior of the depicted child. As that figure illustrates, the child’s body weight transitions from the force plate to the bars, with the lower bar bearing nearly all of the weight. The horizontal forces on the upper and lower bars are approximately equal in magnitude and opposite in direction, consistent with the posture being approximately static toward the end of

the test, where the child completed the ascend maneuver. Under these conditions, the behavior is no longer dynamic, and the vertical forces sum to body weight.

UMTRI researchers modeled a child interacting with a CSU with opened drawers, by measuring forces at instrumented bars representing a drawer front or handle. Figure 7 is the free-body diagram of the child climbing the CSU. The horizontal and vertical forces at the hands and feet correspond to the

positive direction of the measured forces. The CSU drawers were modeled using the top handle and bottom handle height, and the drawer extension was modeled from 0 inches to 12 inches.<sup>59</sup> The UMTRI researchers calculated the moment about the CSU’s front foot or fulcrum, using the measured forces, vertical location of the top and bottom handles, and the defined drawer extension length (Fulcrum X).

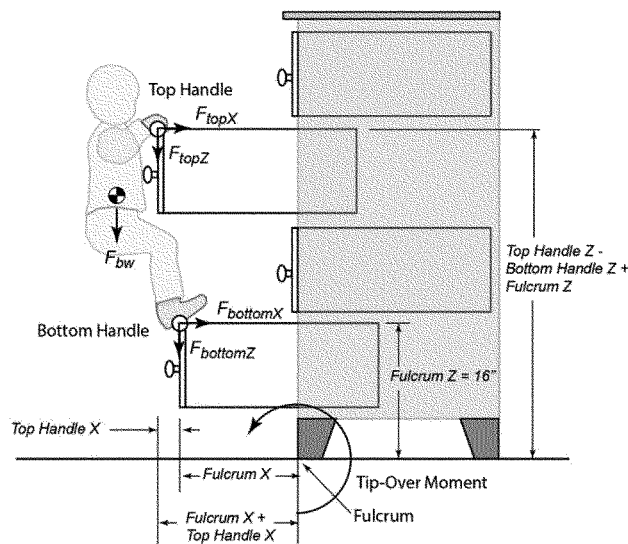

**Figure 7. Free-body diagram of a child climbing a CSU.**

Figure 7 shows that the child’s body weight will generally be distributed

between the two bars, but that the child’s CM location will also typically

be outboard of the bars (farther from the fulcrum than the bars). The quasi-static

<sup>59</sup> Here, 0 inches corresponds with a closed drawer when the fulcrum lines up with the

drawers. Additionally, 12 inches represents the

90th percentile drawer extension length in a dataset of approximately 180 CSUs.



climbing moment is approximately equal to the location of the child's CM (the horizontal distance of the CM to the fulcrum), multiplied by the child's weight. In reality, the moment created by dynamic forces generated by the child during the activities in the UMTRI study, such as during ascend, exceed the moment created by body weight alone as a result of the greater magnitude horizontal and vertical forces.

#### 6. Moment About the Fulcrum

UMTRI researchers analyzed the force data as generating a moment around a tip-over fulcrum. The UMTRI researchers calculated the maximum moment about a virtual fulcrum, based on the measured force data for each test and the location of the force. Figure 8 shows the test setup and the forces measured. Note that the test setup mimics a CSU with the drawers closed and the  $Fulcrum X = 0$ . UMTRI researchers defined the horizontal

$Fulcrum X$  distance of 1-foot (based on the 90th percentile drawer extension) to simulate a 1-foot drawer extension. The bottom handle vertical  $Fulcrum Z$  was set to 16 inches (based on the 90th percentile drawer height from the floor), and the  $Top Handle Z$  varied, depending on the size of the child.<sup>60</sup> Researchers calculated the moment that would be generated for a child interacting on a 1-foot extended CSU drawer, as shown in Figure 8, where  $Fulcrum X = 1$  foot.

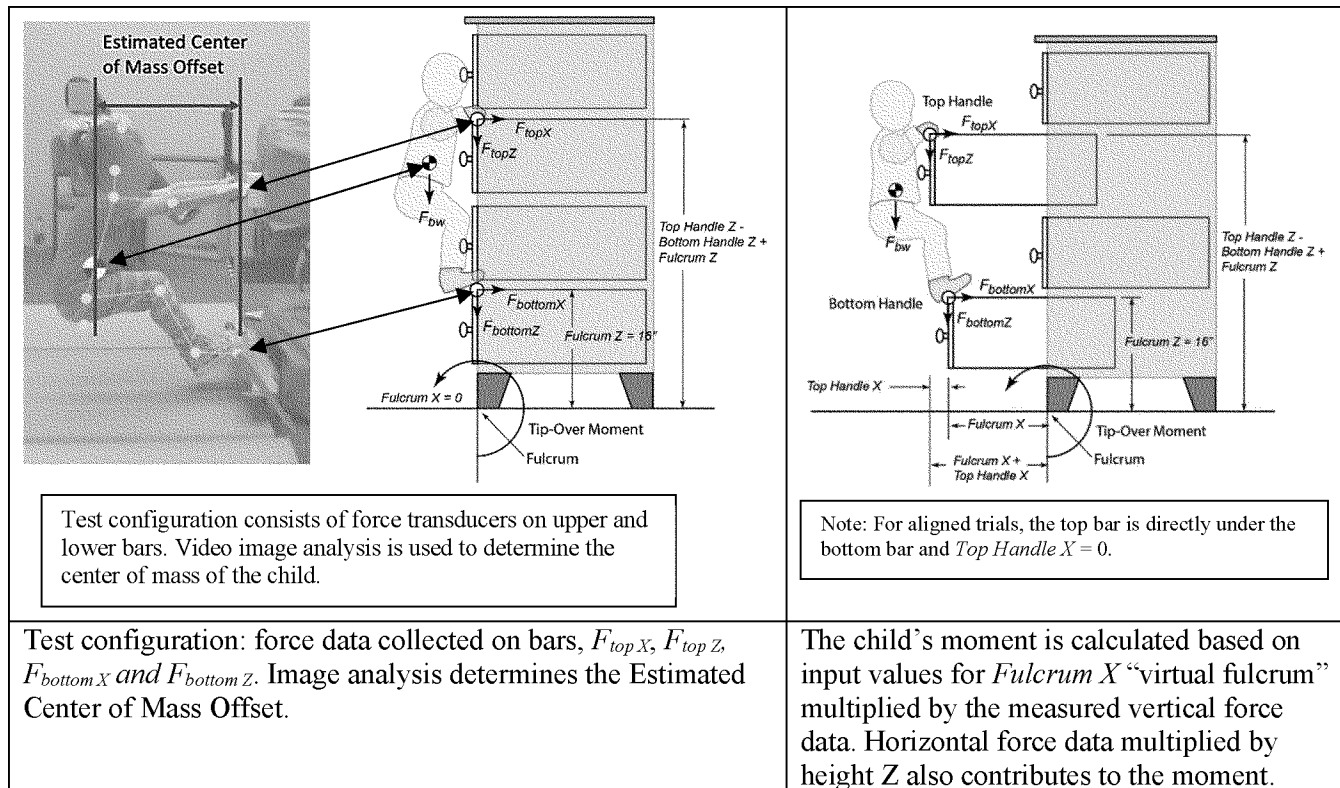

**Figure 8. These diagrams illustrate how the test configuration was used to determine the child's moment acting on the CSU.**

Figure 20 in Tab D of the NPR briefing package (also Figure 44 in Tab R) shows the calculated maximum moment for each interaction of interest versus the child's body weight, and shows that the maximum moment tends to increase with body weight. UMTRI researchers normalized the moment by dividing the calculated moment by the child's body weight to enable the effects of the behaviors to be examined independent of body weight, as shown in Figure 21 in Tab D of the NPR briefing package (also Figure 46 in Tab R). As the figure illustrates, the greatest moments were generated in the Yank interaction,

followed in descending order by Lean, Bounce, 1 Hand, and Ascend. As the weight of the child increased, so did the maximum moment. For all of the interactions, the maximum moment exceeded the weight of the child. For Ascend and Bounce, the slopes are close to zero, indicating that the difference in the moment generated for the Ascend and Bounce interaction is primarily due to the child's weight. A weak positive relationship can be seen for Lean and Yank. This suggests a difference in the Lean and Yank behavior for heavier children that is not accounted for by body weight. This difference for the

Lean and Yank behavior is consistent with the heavier children also having longer arms and legs that would allow them to shift their CM further away from the handles, as well as being relatively stronger, leading to greater magnitude dynamic forces.

The preceding analysis was based on a 12-inch (one foot) horizontal distance between the location of force exertion and the fulcrum. The following analysis shows the effects of varying the  $Fulcrum X$  value, which is equivalent to a CSU's drawer extension from the fulcrum.

The net moment can be calculated using a  $Fulcrum X = 0$  position, as

<sup>60</sup>The top handle varied from 7.4 to 47.3 inches above the bottom handle.

shown in Figure 9, to bound the effects of drawer extension. Placing the fulcrum directly under the hands and

feet in the aligned conditions eliminates the effects of vertical forces on moment,

while amplifying the relative effects of horizontal forces.

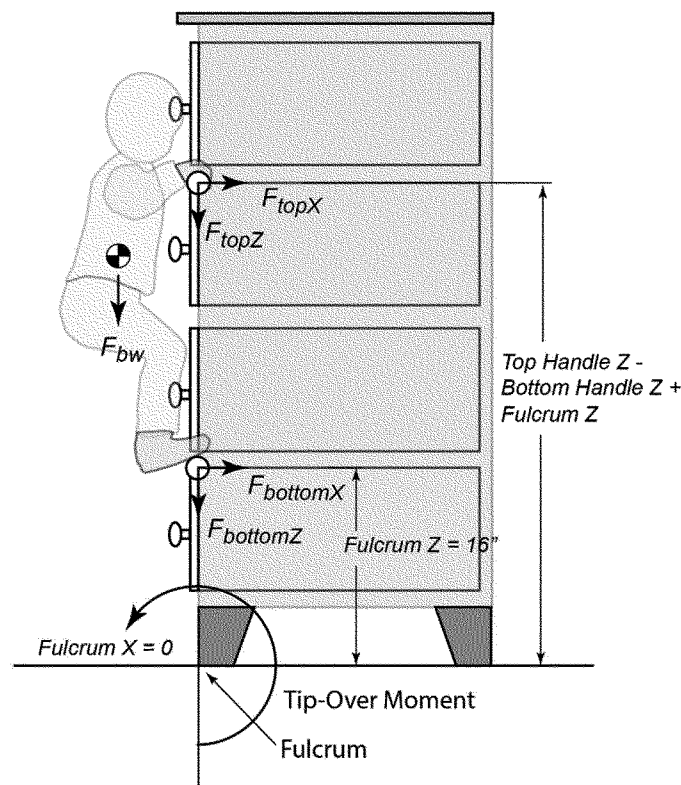

**Figure 9. Depicts a schematic of effects of reducing *Fulcrum X* to zero (compare with Figure 7, which depicts a non-zero *Fulcrum X* distance).**

**BILLING CODE 6355-01-C**

UMTRI researchers analyzed the effects of the *Fulcrum X* (which corresponds to the drawer extension)<sup>61</sup> on the tip-over moment for the targeted behaviors. Since the moment about the fulcrum was calculated based on measured force data and input values for *Fulcrum X* distance, the authors were able to analyze the effects of the fulcrum position by varying the *Fulcrum X* value from 0 to 12 inches. UMTRI researcher used this virtual *Fulcrum X* value to calculate the corresponding maximum moment.

Figure 23 in Tab D of the NPR briefing package (also Figure 51 in Tab R) shows the maximum moments versus the *Fulcrum X* values of 0 and 12 inches across behaviors for aligned conditions. For example, the calculated moment for

Ascend at X=0 is about 17.5 pound-feet. The moment when X=0 is due entirely to horizontal forces. These horizontal forces exerted by the child on the top and bottom handles of the test apparatus are necessary to balance his/her outboard CM. UMTRI researchers concluded that the child's CM due to their postures have strong effects on the horizontal forces exerted and the calculated moments. Consequently, the location of the child's CM during the behavior is an important variable.

As previously discussed, the UMTRI researchers normalized the moment by dividing the calculated moment of each trial by the child's body weight to enable the effects of the behaviors to be examined independent of body weight. The graphs of Figure 23 in Tab D of the NPR briefing package show how the moments and the normalized moments increase with the fulcrum distance (which corresponds to the drawer extension). For the normalized moments shown in the bottom graph, this can be interpreted as the effective CM location outboard of the front foot of the CSU

(fulcrum), in feet. For example, a child climbing on a drawer extended 12 inches (1 foot) from the front foot fulcrum will have an effective CM that is about 19 inches (1.6 feet) from the fulcrum. At *Fulcrum X* = 0, the contribution of vertical forces to the moment are eliminated, and only the horizontal forces exerted at the hands and feet contribute to the moment. The horizontal forces exerted by the child on the top and bottom handles are necessary to balance his/her outboard CM. The effective moment where the fulcrum = 0 is about 6 inches (0.5 feet) for the Ascend behavior, and it is primarily due to the outboard CM position of the child about 6 inches (0.5 feet) from the fulcrum.<sup>62</sup>

As the drawer is pulled out farther from the fulcrum, vertical forces have a greater impact on the total moment contribution. UMTRI researchers reported that at the time of peak

<sup>61</sup>Drawer extension data provided by CPSC staff to UMTRI researchers was measured from the extended drawer to the front of the CSU, and did not account for how the fulcrum position will vary with foot geometry and position. UMTRI researchers assumed that the fulcrum was aligned with the front of the CSU to simplify their analysis.

<sup>62</sup>UMTRI researchers reported that the average CM offset was 6.1 inches (0.51 feet) during ascent at the time the maximum moment was measured.

moment during ascent, the average (median) vertical force, divided by the child's body weight, was close to 1 (staff estimates this value is approximately 1.08 for aligned handle trials).<sup>63</sup> This suggests child body weight is the most significant vertical force, although dynamic forces also contribute.

Based on the Normalized Moment for Ascend shown in the bottom graph of Figure 23 in Tab D of the NPR briefing package, CPSC staff estimated the Ascend line with the following equation 1:

$$\text{Equation 1. Normalized Moment for Ascend} = 1.08 \times [\text{Fulcrum } X \text{ (ft)}] + 0.52 \text{ ft.}$$

Equation 1 can be multiplied by a child's weight to estimate the moment  $M$  generated by the child ascending, as shown in Equation 2:

$$\text{Equation 2. } M = \{1.08 \times [\text{Fulcrum } X \text{ (ft)}] + 0.52 \text{ ft.}\} \times \text{child body weight (lb)}$$

For example: For a 50-pound child ascending the CSU with a 1-foot drawer extension, the moment at the fulcrum is:

$$M = \{1.08 \times [1 \text{ ft}] + 0.52 \text{ ft}\} \times 50 \text{ lb} = 54 \text{ lb-ft} + 26 \text{ lb-ft}$$

$$M = 80 \text{ lb-ft}$$

The child in the example above produces a total moment of 80 pound-feet about the fulcrum. The contribution to the total moment from vertical forces, such as body weight and vertical dynamic forces, is 54 pound-feet. The contribution to the total moment from horizontal forces, such as the quasi-static horizontal force used to balance the child's CM in front of the extended drawer and dynamic forces, is 26 pound-feet.

Similar climbing behaviors for drawer and table trials (e.g., climbing into the drawer or climbing onto the tabletop) generated lower moments than ascent. Therefore, the equation for ascend is expected to cover those behaviors as well.

## 7. Summary of Findings From the Interaction Portion of the Study

UMTRI researchers found that the moments caused by children climbing furniture exceed the effects of body weight alone. CPSC staff used the findings to develop an equation that could be used to calculate the moment generated by children ascending a CSU, based on the child's body weight and the drawer extension from the CSU fulcrum, shown in Equation 2. This equation, combined with the weight for the children involved in CSU tip-over incidents, is the basis for the moment requirements in the proposed rule.

<sup>63</sup> Refer to Figure 48 in the UMTRI report (Tab R of the NPR briefing package).

## 8. Focus Group Portion of UMTRI Study

In addition to examining the forces children generate when interacting with a CSU, in the UMTRI study, the researchers also asked participants and their caregivers questions about participants' typical climbing behaviors. This portion of the study identified many household items that children showed interest in climbing, including: CSUs, tables, desks, counters, cabinets, shelves, windows, sofas, chairs, and beds. In the same study, six children climbed dressers, based on caregivers' reports. Caregivers described various tactics the children used for climbing, such as "jumped up," "hands and feet," "ladder style," and "grab and pull up," but the most common strategy was stepping into or onto the lowest drawer. Caregivers also mentioned children using chairs, stools, and other objects to facilitate climbing, including pulling out dresser drawers.

### C. Flooring<sup>64</sup>

To examine the effect of flooring on the stability of CSUs, staff reviewed existing information and conducted testing. As background, staff considered a 2016 study on CSU stability, conducted by Kids in Danger (KID) and Shane's Foundation.<sup>65</sup> In that study, researchers tested the stability of 19 CSUs, using the stability tests in ASTM F2057-19 on both a hard, flat surface, and on carpeting. The results showed that some CSUs that passed on the hard surface, tipped over when tested on carpet.

To further examine the effect of carpeting on the stability of CSUs, staff tested 13 CSUs, with a variety of designs and stability, on a carpeted test surface. For this testing, staff used a section of wall-to-wall tufted polyester carpeting with polypropylene backing from a major home-supply retailer and typical of wall-to-wall carpeting, based on staff's review of carpeting on the market. Staff installed and secured the carpet, with a carpet pad, on a plywood platform, and conditioned the CSU and carpeting by weighting the unit for 15 minutes. Staff then tested the unit using the same methods and CSU configurations (i.e., number and position of open and filled drawers) as used with these units in the Multiple Open and Filled Drawers testing conducted on the hard surface (Tab O of the NPR briefing package).

<sup>64</sup> Details regarding staff's assessment of the effect of flooring on CSU stability is available in Tab D and Tab P of the NPR briefing package.

<sup>65</sup> *Furniture Stability: A Review of Data and Testing Results* (Kids in Danger and Shane's Foundation, August 2016).

Using the 1,221 pairs of tip weights (i.e., tip weight on the flat surface and on the carpet, with various configurations of multiple open and filled drawers), staff calculated the difference in tip weight when on the hard surface, compared to the carpeted surface for each CSU (tip weight difference). A CSU had a positive tip weight difference if the tip weight was higher on the hard surface than on the carpet, indicating that CSUs are less stable on carpet. The testing showed the CSUs tended to be more stable on the hard surface than they were on carpet. Of the 1,221 tip-over weight differences, the tip weight difference was positive for 1,149 (94 percent) of them; negative for 33 (3 percent) of them; and was zero (i.e., the tip-over weights were equal) for 39 (3 percent). For all 1,221 combinations, the mean tip weight difference was 7.6 pounds, but for individual units, the mean tip weight difference ranged from 4.1 to 16.0 pounds. For all 1,221 combinations, the median tip weight difference was 7 pounds, but for individual units, the median ranged from 2 to 16 pounds. The standard deviation for the entire 1,221 data set was 5.1 pounds, but was smaller for individual units, ranging from 1.8 to 4.7 pounds, indicating that most of the variability in tip weight differences was between units, as opposed to within units, which suggests that some units are affected more than others by carpeting.

Staff also analyzed the relationship between tip weight difference and open/closed drawers and filled/empty drawers. The mean tip weight difference was 7.6 pounds (median was 7 pounds) when most of the drawers on the unit were open, and 8.5 pounds (median was 8 pounds) when most of the drawers were closed, indicating that the units were more stable (required more weight to tip over) when more drawers were closed. The mean tip weight difference was 7.2 pounds (median was 6 pounds) when most of the drawers on the unit were empty, and 7.7 pounds (median was 7 pounds) when most of the drawers were filled.<sup>66</sup> This shows that, in general, CSUs are less stable on carpet. All units tested, under various conditions, tended to tip with less

<sup>66</sup> To further assess whether the effect of carpet changed based on the CSU's stability—that is, to determine if the results reflected the change in flooring, or the overall stability of the unit—staff calculated the percent tip weight difference, as: Percent tip weight difference = (hard surface tip weight – carpet tip weight)/hard surface tip weight. This revealed that, as the weight to tip the unit on a hard surface increased, shifting to a carpeted surface had less of an impact in terms of the percentage of the tip-over weight.

weight on the carpet than on the hard surface.

Staff used the results from this study to determine a test method that approximated the effect of carpet on CSU stability by tilting the unit forward (Tab D of the NPR briefing package). Using the CSUs that were involved in CSU tip-over incidents (Tab M of the NPR briefing package), staff compared 9 tip weights on carpet with tip weights for the same units in the same test configuration when tilted at 0, 1, 2, and 3 degrees in the forward direction on an otherwise hard, level, and flat surface.

The tip weight of CSUs on carpet corresponded with tilting the CSUs 0.8 to 3 degrees forward, depending on the CSU; the mean tilt angle that corresponded to the CSU tip weights on carpet was 1.48 degrees. This suggests that a forward tilt of 0.8 to 3 degrees replicated the test results on carpet. Staff also conducted a mechanical analysis of the carpet and pad used in the test assembly, and found a similar forward tilt of 1.5 to 2.0 degrees would replicate the effects of carpet for one CSU.

#### D. Incident Recreation and Modeling<sup>67</sup>

CPSC staff analyzed incidents and tested products that were involved in CSU tip-over incidents to better understand the real-world factors that contribute to tip overs. Staff analyzed 7 CSU models, associated with 13 tip-over incidents. The CSUs ranged in height from 27 to 50 inches and weighed between 45 and 195 pounds. Two of these CSU models did not comply with the stability requirements in ASTM F2057–19; one complied with the requirements in section 7.1, but not section 7.2; two complied with both sections 7.1 and 7.2; and one was borderline.<sup>68</sup> Through testing and analysis, staff recreated the incident scenarios described in the investigations and determined the weight that caused the unit to tip over in a variety of use scenarios, such as a child climbing or pulling on the dresser, multiple open drawers, filled and unfilled drawers, and the flooring under the CSU.

Based on this analysis and testing, staff identified several factors that contributed to the tip-over incidents.

<sup>67</sup> Details about staff's incident recreation and modeling are in Tab D and Tab M of the NPR briefing package.

<sup>68</sup> Staff tested this model two separate times. In one case, the tip weight just exceeded the ASTM F2057–19 minimum acceptable test fixture weight. In another case, the model tipped over just below the minimum allowed test fixture weight. These results are consistent with earlier staff testing that found that the model tipped when tested with a 49.66-pound test fixture; but did comply when tested with a 48.54-pound test fixture.

One factor was whether multiple drawers were open simultaneously. Opening multiple drawers decreased the stability of the CSU. A related factor was whether the drawers of the CSU were filled, and to what extent. Staff's testing indicated that the weight of filled drawers increases the stability of a CSU when more drawers are closed, and reduces overall stability when more drawers are open. Generally, when more than half of filled drawers were open (by volume), the CSU was less stable.

Another factor was the child's interaction with the CSU at the time of the incident. In some incidents, the child was likely exerting both a horizontal and vertical force on the CSU. Staff found that, for some CSUs, either a vertical or horizontal force, alone, could cause the CSU to tip over, but that the presence of both forces significantly increased the tip-over moment acting on the CSU. These forces, in combination with the other factors staff identified, further contributed to the instability of CSUs. Some of the incident recreations indicated that the force on the edge of an open drawer associated with tipping the CSU was greater than the static weight of the child standing on the edge of an open drawer of the CSU. The equivalent force consists of the child's weight, the dynamic force on the edge of the drawer due to climbing, and the effects of the child's CG extending beyond the edge of the drawer. Some of the incident recreations indicated that a child pulling on a drawer could have contributed to the CSU tipping over.

Another factor that contributed to instability was flooring. Staff's testing indicated that the force needed to tip a unit over was less when the CSU was on carpet/padding than when it was on a hard, level floor.

#### E. Consumer Use Study<sup>69</sup>

In 2019, the Fors Marsh Group (FMG), under contract with CPSC, conducted a study to assess factors that influence consumer attitudes, behaviors, and beliefs regarding CSUs. The study consisted of two components. In the first component, the researchers conducted six 90-minute in-home interviews (called ethnographies). Three of the participants had at least one child between 18 and 35 months old in the home, and three participants had at least one child between 36 and 72 months old in the home. In this phase of the study, the researchers collected

<sup>69</sup> The full report from FMG, *Consumer Product Safety Commission: Furniture Tipover Report* (Mar. 13, 2020), is available in Tab Q of the NPR briefing package.

information about family interactions with and use of CSUs in the home.

In the second component of the study, FMG conducted six 90-minute focus groups, using a total of 48 participants. Each focus group included eight participants with the same caregiver status (parents of a child between 1 and 5 years old, people who are visited regularly by a child between 1 and 5 years old, and people who plan to have children in the next 5 years) and homeowner status (people who own their home, and people who rent their home). Participants included parents of children 12 to 72 months old, people without young children in the home who were planning to have children in the next 5 years, and people without young children in the home who are visited regularly by children 12 to 72 months old. The focus groups assessed consumer perceptions of and interactions with CSUs, perceptions of warning information, and factors that influence product selection, classification, and placement.

In describing CSUs, participants mentioned freestanding products; products that hold clothing; features to organize or protect clothing (e.g., drawers, doors, and dividers); and named, as examples, dressers, armoires, wardrobes, or units with shelving or bins. Participants noted that whether storage components were large enough to fit clothing was relevant to whether a product was a CSU. However, participants also noted that they may use smaller, shorter products, with smaller storage components, as CSUs in children's rooms so that children can access the drawers, and because children's clothes are smaller. In distinguishing nightstands from CSUs, participants noted the size and number of drawers, and some reported storing clothing in them. Some participants reported that how products were displayed in stores or in online marketing did not influence how they used the unit in their homes, and indicated that although a product name may have some influence on their perception of the product, they would ultimately choose and use a product based on its function and ability to meet their needs.

Focus group participants were provided with images of various CSU-like products, and asked what they would call the product, what they would put in it, and where they would put it. Participants provided diverse answers for each product, with products participants identified as buffets, nightstands, entry/side/hall tables, or entertainment/TV/media units also being called dressers or armoires by

other participants. Products that participants were less likely to consider a CSU or use for clothing had glass doors, removable bins/baskets, or a small number of small drawers.

Participants primarily kept CSUs in bedrooms and used them to store clothing. However, they also noted that they had products that could be used as CSUs in other rooms to store non-clothing, and had changed the location and use of products over time, moving them between rooms and storing clothing or other items in them, depending on location.

Focusing on units that the participants' children interacted with the most, the researchers noted that CSUs in children's rooms held clothing and were 70 to 80 percent full of folded clothing. Participants reported that the children's primary interaction with CSUs was opening them to reach clothing, but also reported children climbing units to reach into a drawer or to reach something on top of the unit. A few participants reported having anchored a CSU. As reasons for not anchoring furniture, participants stated that they thought the unit was unlikely to tip over, particularly smaller and lighter units used in children's rooms, and they do not want to damage walls in a rental unit.

#### F. Tip Weight Testing<sup>70</sup>

As discussed earlier in this preamble, in 2016 and 2018–2019, CPSC staff tested CSUs to assess compliance with requirements in ASTM F2057. As part of the 2018–2019 testing, staff also assessed whether CSUs could hold weights higher than the 50-pound weight required in ASTM F2057, testing the CSUs with both a 60-pound test weight, and to the maximum test weight they could hold before tipping over. For this testing, staff assessed 188 CSUs, including 167 CSUs selected from among the best sellers from major retailers, using a random number generator; 4 CSU models that were

<sup>70</sup> A full discussion of this testing and the results is available in Tab N of the NPR briefing package.

involved in incidents;<sup>71</sup> and 17 units assessed as part of previous test data provided to CPSC.<sup>72</sup> Appendix A to Tab N in the NPR briefing package describes the test procedure staff followed. To summarize, after recording information about the weight, dimensions, and design of the CSU, staff used a test procedure similar to section 7.2 in ASTM F2057–19 (loaded weight testing), but with a 60-pound test fixture, and with test fixtures that allowed staff to add additional weight, in 1-pound increments, up to a maximum of 134 pounds.

Of the 188 CSUs staff tested, 98 (52 percent) held the 60-pound weight without tipping over. The mean weight at which the CSUs tipped over was 61.7 pounds and the median was 62 pounds.<sup>73</sup> The lowest weight that caused a CSU to tip over was 12.5 pounds. The next lowest tip weights were 22.5 pounds (2 CSUs), 25 pounds (6 CSUs), and 27.5 pounds (3 CSUs). One CSU did not tip over when the maximum 134-pound test weight was applied. The next highest tip weights were 117.5 pounds (1 CSU), 112.5 pounds (1 CSU), 102.5 pounds (1 CSU), 97.5 pounds (1 CSU), 95 pounds (1 CSU), and 90 pounds (4 CSUs). Most CSUs tipped over with between 45 and 90 pounds of weight.

#### G. Warning Label Symbols<sup>74</sup>

In 2019, CPSC contracted a study to evaluate a set of 20 graphical safety symbols for comprehension, in an effort to develop a family of graphical symbols that can be used in multiple standards to communicate safety-related

<sup>71</sup> Staff tested exemplar units, using the model of CSU involved in the incident, but not the actual incident unit.

<sup>72</sup> The CSUs were identified from the Consumer Reports study "Furniture Tip-Overs: A Hidden Hazard in Your Home" (Mar. 22, 2018), available at: <https://www.consumerreports.org/furniture/furniture-tip-overs-hidden-hazard-in-your-home/>.

<sup>73</sup> This is based on the results for 185 of the units; staff omitted the test weight for 3 of the CSUs because of data discrepancies.

<sup>74</sup> Further details regarding staff's analysis of warning label symbols are available in Tab C of the NPR briefing package.

information to diverse audiences.<sup>75</sup> The contractor developed 10 new symbols for the project, including one showing the CSU tip-over hazard and one showing the CSU tip-over hazard with a tip restraint; the remaining 10 symbols already existed. The contractor recruited 80 adults and used the open comprehension test procedures described in ANSI Z535.3, *American National Standard Criteria for Safety Symbols* (2011).

One of the existing symbols the contractor evaluated is the child climbing symbol from the warning label in ASTM F2057. The symbol showed poor comprehension (63.8 percent) with strict (*i.e.*, fully correct) scoring criteria, but passing comprehension (87.5 percent), when scored with lenient (*i.e.*, partially correct) scoring criteria. ANSI Z535.3 defines the criteria for "passing" as at least 85 percent correct interpretations (strict), with fewer than 5 percent critical confusions (*i.e.*, the opposite action is conveyed). There was no critical confusion with the symbol.

The contractor conducted focus groups consisting of 40 of the 80 individuals who went through the comprehension study. Based on the feedback received in the comprehension study and in focus groups, the contractor developed the two new symbol variants shown in Figure 10. CPSC staff is currently working with the contractor to test these new symbol variants using the same methodology applied in the previous study. CPSC staff plans to assess whether one of the two variants performed better in comprehension testing than the F2057 child climbing symbol, and thereafter, will determine whether any changes to the symbol proposed in this NPR should be modified for the final rule.

<sup>75</sup> Kalsher, M., CPSC Gather Consumer Feedback: Final Report (2019), available at: <https://www.cpsc.gov/s3fs-public/CPSC%20Gather%20Consumer%20Feedback%20-%20Final%20Report%20with%20CPSC%20Staff%20Statement%20-%20REDACTED%20and%20CLEARED.pdf?GTPK5CxxCRmftdywdDGXJyVIVq.GU2Tx>.

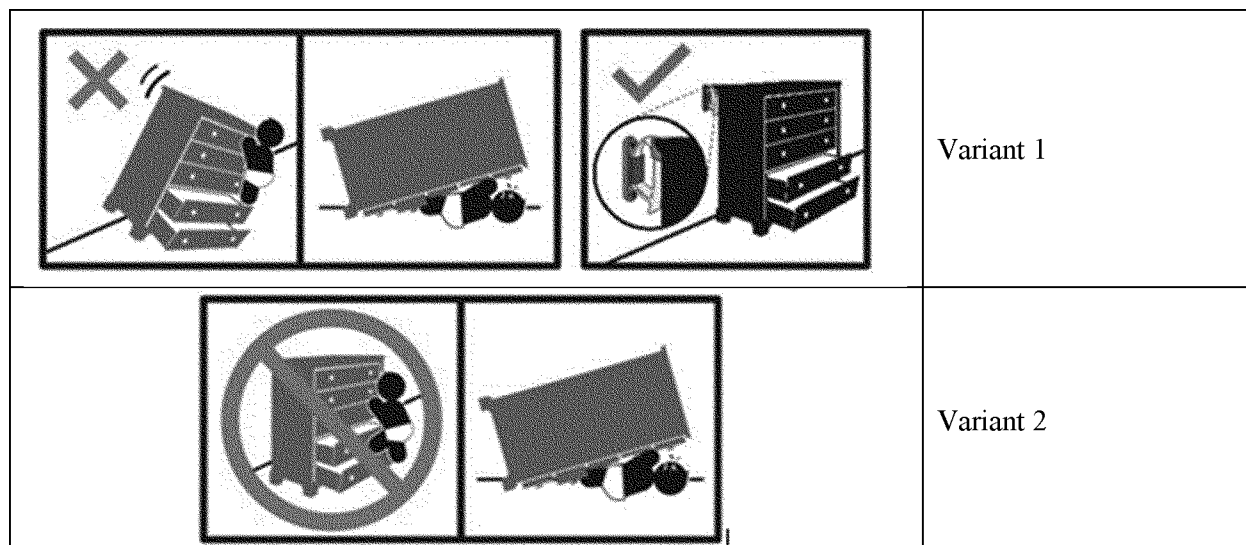

**Figure 10: Two variant symbols being tested (one showing the importance of anchoring the CSU, the other demonstrating the tip-over hazard as a result of climbing). Note: the symbols are reproduced in grayscale here, but the color version includes a red “x” and prohibition symbol, and a green check mark.**

#### H. Tip Restraints and Anchoring<sup>76</sup>

CPSC considered several studies regarding consumer anchoring of furniture to evaluate the potential effectiveness of tip restraints to help address the tip-over hazard. These studies indicate that a large number of consumers do not anchor furniture, including CSUs, in their homes, and that there are several barriers to anchoring, including consumer beliefs, and lack of knowledge about what anchoring hardware to use or how to properly install it.

A CPSC Consumer Opinion Forum survey in 2010, with a convenience sample of 388 consumers, found that only 9 percent of those who responded to the question on whether they anchored the furniture under their television had done so (27 of 295).<sup>77</sup> Although a majority of respondents reported that the furniture under their television was an entertainment center, television stand, or cart, 7 percent of respondents who answered this question (22 of 294) reported using a CSU to hold their television.<sup>78</sup> The consumers who reported using a CSU to

hold their television had approximately the same rate of anchoring the CSU, 10 percent (2 of 21),<sup>79</sup> as the overall rate of anchoring furniture found in the study.

In 2018, Consumer Reports conducted a nationally representative survey<sup>80</sup> of 1,502 U.S. adults, and found that only 27 percent of consumers overall, and 40 percent of consumers with children under 6 years old at home, had anchored furniture in their homes. The study also found that 90 percent of consumers have a dresser in their homes, but only 10 percent of those with a dresser have anchored it. Similarly, although 50 percent of consumers have a tall chest or wardrobe in their homes, only 10 percent of those with a tall chest or wardrobe have anchored it. The most common reasons consumers provided for not anchoring furniture, in declining order, included that their children were not left alone around furniture; they perceived the furniture to be stable; they did not want to put holes in the walls; they did not want to put holes in the furniture; the furniture did not come with anchoring hardware; they did not know what hardware to use; and they had never heard of anchoring furniture.

As discussed earlier in this preamble, the Commission launched the education campaign—Anchor It!—in 2015 to promote consumer use of tip restraints to anchor furniture and televisions. In 2020, a CPSC-commissioned study assessed consumer awareness, recognition, and behavior change as a result of the Anchor It! campaign.<sup>81</sup> The study included 410 parents and 292 caregivers of children 5 years or younger from various locations in the United States. The survey sought information about whether participants had ever anchored furniture in their homes, and their reasons for not anchoring furniture. The study found that 55 percent of respondents reported ever having anchored furniture, with a greater percentage of parents reporting anchoring furniture (59 percent) than other caregivers (50 percent), and a greater percentage of homeowners reporting ever having anchored furniture (57 percent) than renters (51 percent). For participants who did not report anchoring furniture or televisions, the most common reasons respondents gave for not anchoring, in declining order, were that they did not believe it was necessary, they watch their children, they have not gotten to it yet, it would damage walls, and they do not know what anchors to use.

<sup>76</sup> Further information about tip restraints and anchoring is in Tab C of the NPR briefing package.

<sup>77</sup> Butturini, R., Massale, J., Midgett, J., Snyder, S. Preliminary Evaluation of Anchoring Furniture and Televisions without Tools, Technical Report CPSC/EXHR/TR—15/001 (2015), available at: <https://www.cpsc.gov/s3fs-public/pdfs/Tipover-Prevention-Project-Anchors-without-Tools.pdf>.

<sup>78</sup> Three consumers identified the furniture as an “armoire,” and 19 consumers identified the furniture as a “dresser, chest of drawers, or bureau.”

<sup>79</sup> Although 22 respondents reported using a CSU under their television, one of these respondents answered “I don’t know” to the question about whether they anchored the furniture.

<sup>80</sup> Consumer Reports, Furniture Wall Anchors: A Nationally Representative Multi-Mode Survey (2018), available at: [https://article.images.consumerreports.org/prod/content/dam/surveys/Consumer\\_Reports\\_Wall\\_Anchors\\_Survey\\_2018\\_Final](https://article.images.consumerreports.org/prod/content/dam/surveys/Consumer_Reports_Wall_Anchors_Survey_2018_Final).

<sup>81</sup> The report for this study, Fors Marsh Group, CPSC Anchor It! Campaign: Main Report (July 10, 2020), is available at: [https://www.cpsc.gov/s3fs-public/CPSC-Anchor-It-Campaign-Effectiveness-Survey-Main-Report\\_Final\\_9\\_2\\_2020....pdf?gC1No.oOO2FEXV9wmOtdJVAtacRLHIMK](https://www.cpsc.gov/s3fs-public/CPSC-Anchor-It-Campaign-Effectiveness-Survey-Main-Report_Final_9_2_2020....pdf?gC1No.oOO2FEXV9wmOtdJVAtacRLHIMK).

These results indicate that one of the primary reasons parents and caregivers of young children do not anchor furniture is a belief that it does not need to be anchored if children are supervised. However, research shows that 2- to 5-year-old children are out of view of a supervising parent for about 20 percent of the time that they are awake, and are left alone significantly longer in bedrooms, playrooms, and living room areas.<sup>82</sup> CSUs are likely to be in bedrooms, where children are expected to have unsupervised time, including during naps and overnight. Many of the CSU tip-over incidents occurred in children's bedrooms during these unsupervised times. According to the Consumer Reports study, 76 percent of consumers with children under 6 years old reported that dressers are present in rooms where children sleep or play; and the UMTRI study found that nearly all (95 percent) of child participants had dressers in their bedrooms. Notably, among the 89 fatal incidents, 55 occurred in a child's bedroom, 11 occurred in a bedroom, 2 occurred in a parent's bedroom, and 2 occurred in a sibling's bedroom. None of the fatal incidents occurred when the child was under direct adult supervision. However, some nonfatal incidents occurred during supervised time when parents were in the room with the child. As this indicates, supervision is neither a practical, nor effective way to prevent tip-over incidents.

Another common reason caregivers provided for not anchoring furniture was the perception that the furniture was stable. CPSC staff testing and modeling found that there is a large difference in stability of CSUs, depending on the number of drawers open. Adults are likely to open only one or a couple of drawers at a time on a CSU; as such, adults may only have experience with the CSUs in their more stable configurations and may underestimate the tip-over hazard. In contrast, incident analysis shows that some children open multiple or all drawers on a CSU simultaneously, potentially putting the CSU in a much less stable configuration; and children contribute further to instability by climbing the CSU.

<sup>82</sup> Morrongiello, B.A., Corbett, M., McCourt, M., Johnston, N. Understanding unintentional injury-risk in young children I. The nature and scope of caregiver supervision of children at home, *Journal of Pediatric Psychology*, 31(6): 529–539 (2006); Morrongiello, B.A., Ondejko, L., Littlejohn, A. Understanding Toddlers' In-Home Injuries: II. Examining Parental Strategies, and Their Efficacy, for Managing Child Injury Risk. *Journal of Pediatric Psychology*, 29(6), pp. 433–446 (2004).

CPSC staff also has concerns about the effectiveness of tip restraints and identified tip-over incidents in which tip restraints detached or broke. Overall, given the low rates of anchoring, the barriers to anchoring, and concerns about the effectiveness of tip restraints, CPSC concludes that tip restraints are not effective as the primary method of preventing CSU tip overs. Effective tip restraints may be useful as a secondary safety system to enhance stability, such as for interactions that generate particularly strong forces (*e.g.*, bouncing, jumping), or to address interactions from older/heavier children. In addition, tip restraints may help reduce the risk of tip overs for CSUs that are already in homes, since a rule would only apply to CSUs manufactured and imported on or after the effective date. In future work, CPSC may evaluate appropriate requirements for tip restraints, and will continue to work with ASTM to update its tip restraint requirements.

## VIII. Description of and Basis for the Proposed Rule

### A. Scope and Definitions

#### 1. Proposed Requirements

The proposed rule applies to CSUs, defined as a freestanding furniture item, with drawer(s) and/or door(s), that may be reasonably expected to be used for storing clothing, that is greater than or equal to 27 inches in height, and with a total functional volume of the closed storage greater than 1.3 cubic feet and greater than the sum of the total functional volume of the open storage and the total volume of the open space. Several terms in that definition, as well as additional terms in the proposed rule, are also defined in the proposed rule. For example, for purposes of the proposed stability testing, tip over is defined as the point at which a CSU pivots forward such that the rear feet or, if there are no feet, the edge of the CSU lifts at least 1/4 inch from the floor or is supported by a non-support element.

The proposed rule specifically states that whether a product is a CSU depends on whether it meets this definition. However, to demonstrate which products may meet the definition of a CSU, the proposed standard provides names of common CSU products, including chests, bureaus, dressers, armoires, wardrobes, chests of drawers, drawer chests, chifforobes, and door chests. Similarly, it names products that generally do not meet the criteria in the proposed CSU definition, including shelving units, office furniture, dining room furniture, laundry hampers, built-in closets, and

single-compartment closed rigid boxes (storage chests).

Additionally, the proposed rule exempts from its scope two products that would meet the proposed definition of a CSU—clothes lockers and portable storage closets. It defines clothes locker as a predominantly metal furniture item without exterior drawers and with one or more doors that either locks or accommodates an external lock; and defines portable storage closet as a freestanding furniture item with an open frame that encloses hanging clothing storage space and/or shelves, which may have a cloth case with a curtain(s), flap(s), or door(s) that obscures the contents from view.

#### 2. Basis for Proposed Requirements

To determine the scope of products that the proposed rule should address, in order to adequately reduce the risk of injury from CSU tip overs, staff considered the nature of the hazard, assessed what products were involved in tip-over incidents, and assessed the characteristics of those products in relation to stability and children's interactions.

##### a. The Hazard

The CSU tip-over hazard relates to the function of CSUs, where they are used in the home, and their design features. A primary feature of CSUs is that typically they are used for clothing storage; however, putting clothing in a furniture item does not create the tip-over hazard on its own. Rather, the function of CSUs as furniture items that store clothing means that consumers and children are likely to have easy access to the unit and interact with it daily, resulting in increased exposure and familiarity. In addition, caregivers may encourage children to use a CSU on their own as part of developing independent skills. As a result, children are likely to know how to open drawers of a CSU, and are likely to be aware of their contents, which may motivate them to interact with the CSU. For this reason, one element of the proposed definition of CSUs is that they be reasonably expected to be used for storing clothing.

CSUs are commonly used in bedrooms, an area of the home where children are more likely to have unsupervised time. As stated, most CSU tip-over incidents occur in bedrooms: Among the 89 fatal tip-over incidents involving children and CSUs without televisions, 99 percent of the incidents with a reported location (70 of 71

incidents) occurred in a bedroom.<sup>83</sup> This use means that children have more opportunity to interact with the unit unsupervised, including in ways more likely to cause tip over (e.g., opening multiple drawers and climbing) that a caregiver may discourage.

Another primary feature of CSUs is closed storage, which is storage within drawers or behind doors. These drawers and doors are extension elements, which allow children to exert vertical force further from the tip point (fulcrum) than they would be able to without extension elements and that make it more likely that a child will tip the product during interactions. In addition, these features may make the product more appealing to children as a play item. Children can open and close the drawers and doors and use them to climb, bounce, jump, or hang; they can play with items in the drawers, or get inside the drawers or cabinet. Children can also use the CSU extension elements for functional purposes, such as climbing to reach an item on top of the CSU. Accordingly, the proposed definition of CSUs includes a minimum amount of closed storage and the presence of drawers and/or doors as an element. The element of the definition that indicates that a CSU has a total functional volume of the closed storage greater than 1.3 cubic feet and greater than the sum of the total functional volume of the open storage and the total volume of the open space is based on the total functional drawer volume for the shortest/lightest reported CSU involved in a nonfatal incident without a television. CPSC rounded the volume down, so that the CSU would be included in the proposed definition.

The proposed CSUs definition also states that the products are freestanding furniture items, which means that they remain upright, without requiring attachment to the wall, in their normal use position. The lack of permanent attachment to the building structure means that CSUs are more susceptible to tip over than built-in storage items in the home, such as kitchen cabinets and bathroom vanities.

#### b. Product Categories in Incident Data

For this rulemaking, staff focused on product categories that commonly meet the general elements of the definition of a CSU, in analyzing incident data; these included chests, bureaus, dressers, armoires, wardrobes, portable storage closets, and clothes lockers. As detailed

<sup>83</sup> Fifty-five incidents were in a child's bedroom; 11 were in a bedroom; 2 were in a parent's bedroom; 2 were in a sibling's bedroom; and 1 occurred in a hallway. The location in 18 incidents was not clear.

in the discussion of incident data, of the 89 fatal CPSRMS tip-over incidents involving children and CSUs without televisions, 87 involved chests, bureaus, or dressers, and 2 involved wardrobes; none involved an armoire, portable storage closet, or clothes locker. Of the 263 nonfatal CPSRMS incidents with children and CSUs without televisions, 259 involved chests, bureaus, or dressers, 1 involved an armoire, and 3 involved wardrobes. Of the estimated 40,700 ED-treated injuries to children from CSU tip overs (without a television) between January 1, 2006 and December 31, 2019, an estimated 40,200 involved "chests, bureaus, and dressers." There were not enough incidents involving armoires, wardrobes, portable storage closets, or clothes lockers to make estimates for these CSU categories.

Based on these data, the proposed definition of CSUs names chests, bureaus, dressers, wardrobes, and armoires as examples of CSUs that are subject to the standard. The proposed rule exempts clothes lockers and portable storage closets from the scope of the standard because there are no reported tip-over fatalities or injuries to children that involved those products. Compared to chests, bureaus, and dressers, wardrobes and armoires have been involved in fewer tip-over incidents. However, the proposed rule includes these products because there are some tip-over fatalities and injuries involving them, they are similar in design to the other CSUs included in the scope (unlike portable storage closets), and they are more likely to be used in homes than clothes lockers.

#### c. Product Height

ASTM F2057–19 applies to CSUs that are "27 in. (686 mm) and above in height." Previously, the ASTM standard had applied to CSUs taller than 30 inches. However, CPSC staff identified tip-over incidents involving CSUs that were 30 inches in height and shorter, and worked with the ASTM F15.42 Furniture Subcommittee to lower the minimum height of CSUs covered by the standard. This same 27-inch height is used in the proposed rule's definition of a CSU, consistent with this incident data and additional information regarding product heights.

The height of the CSU was reported for 53 fatal and 72 nonfatal CPSRMS tip-over incidents involving children and CSUs without televisions. The shortest reported CSU involved in a fatal incident without a television is a 27.5-inch-tall, 3-drawer chest, which tipped over onto a 2-year-old child. The shortest reported CSU involved in a

nonfatal CPSRMS tip-over incident without a television is a 26-inch-tall, 2-drawer chest.<sup>84</sup> NEISS data do not provide information about the height of CSUs involved in incidents.

Results from the FMG's CSU focus group (Tab Q of the NPR briefing package) suggest that consumers seek out low-height CSUs for use in children's rooms "because participants would like a unit that is an appropriate height (*i.e.*, short enough) for their children to easily access their clothes." The average shoulder height of a 2-year-old is about 27.4 to 28.9 inches.<sup>85</sup> In the in-home interviews, researchers observed that CSUs in children's rooms typically were low to the ground and wide. Based on this information, children may have more access and exposure to low-height CSUs than taller CSUs.

Additionally, staff is aware of shorter CSUs on the market, as short as 18 inches.<sup>86</sup> For example, a major furniture retailer currently sells more than 10 products marketed as "chests" or "dressers," ranging in height from 19.25 inches to 26.75 inches, including a 25.25-inch-tall, 3-drawer chest advertised for use in a child's room. ESHF staff believes that children may still be motivated to climb or otherwise interact with shorter units: Home interview participants in the FMG CSU use study said that children climbed short furniture items in the home, such as nightstands and ottomans. For these reasons, the Commission seeks comments on the 27-inch height specified in the proposed CSU definition.

#### d. Children's Products

As discussed in section III.A. Description of the Product, section 14(a) of the CPSA includes requirements for certifying that children's products and non-children's products comply with applicable mandatory standards, and additional requirements apply to children's products. That section also explains what constitutes a "children's product." To summarize, a "children's product" is a consumer product that is "designed or intended primarily for children 12 years of age or younger." 15 U.S.C. 2052(a)(2).

<sup>84</sup> The product is marketed as a "chest," but was called a "nightstand" in the consumer's report.

<sup>85</sup> The mean standing shoulder height of a 2-year-old male is 28.9 inches and 27.4 inches for a 2-year-old female. Pheasant, S., *Bodyspace Anthropometry, Ergonomics & Design*. London: Taylor & Francis (1986).

<sup>86</sup> Industrial Economics, Incorporated (2019). *Final Clothing Storage Units (CSUs) Market Research Report*. CPSC Contractor Report. Researchers analyzed the characteristics of 890 CSUs, and found a height range of 18 to 138 inches.



CPSC is aware of CSUs that are marketed, packaged, displayed, promoted, or advertised as being for children under 12 years old. These CSUs may be sold as part of matching nursery or children's bedroom furniture sets, or have features or themes that appeal to children, such as bright colors and cartoons. CSUs may be sold at children's retailers, or by manufacturers that specialize in children's furniture.

However, some children's furniture is similar in appearance to general-use furniture. In addition, some CSUs convert from a child-specific design, such as a CSU with an integrated changing table, to a more general-use design. Children's furniture with a more general-use design or with the ability to convert may be appealing to consumers who want furniture that they can continue to use as a child gets older.

CSUs that are children's products have been involved in fatal and nonfatal incidents, and are among recalled CSUs. However, CSUs that are general-use products make up more of the CSUs in the tip-over incident data. Additionally, the CSU study shows that CSUs that children interact with are not limited to CSUs intended for children. For these reasons, the proposed rule applies to both children's products and non-children's products.

#### e. Product Names and Marketed Use

The proposed definition of CSUs relies on characteristics of the unit to identify covered products, rather than product names or the manufacturer's marketed use of the product. This is because, as this preamble discusses, there are various products that consumers identify and use as CSUs, and that pose the same tip-over hazard, regardless of how the product is named or marketed.

In the FMG CSU use study (Tab Q of the NPR briefing package), participants showed flexibility in how they used CSUs and other similar furniture in the home, depending on their needs, aesthetics, and where the unit was placed within the home. For example, one participant put a large vintage dresser in their living room and used it for non-clothing storage; one participant said that their dresser was used as a changing station and held diapers, wipes, creams, and medical supplies, but is now used to store clothes; and a participant said that the dresser in their child's room was originally used to store dishes.

Some participants in the in-home interviews and focus groups used nightstands for clothing storage, including for shirts; socks; pajamas; slippers; underwear; smaller/lighter

items, such as tights or nightwear; seasonal items; and accessories. Some participants also reported storing clothing (*e.g.*, seasonal clothing items, underwear, pajamas, pants) in shelving units with removable bins (including those with cloth, canvas, or basket material). Consumers also had a wide variety of interpretations of the marketing term "accent piece," with some participants saying that they use accent pieces for clothing storage, and one identifying a specific accent piece in their home as a CSU.

As part of the study, researchers asked focus group participants to fill out a worksheet with pictures of unnamed furniture items with dimensions. Participants were asked to provide a product label (category of product) and answer the question: "What would you store in this piece of furniture?" "Where would you put this piece of furniture in your home?" Participants then discussed the items as a group. Results suggest that there is wide variety in how people perceive a unit. For example, one unit in the study was classified by participants as a cabinet, television stand, accent/occasional/entryway piece or table, side table/sideboard, nightstand, kitchen storage/hutch/drawer, and dresser. Another was classified as an accent piece, buffet/sideboard, dresser, entry/hall/side table, chest/chest of drawers, kitchen storage unit/cabinet, sofa table, bureau, and china cabinet. One interesting item of discussion was the glass doors on one of the worksheet furniture items. Participants came to a general consensus that glass doors are typically used to display items, and thus, an item with glass doors is not a CSU.

Overall, the results from the study suggest that there is not a distinct line between units that people will use for clothing storage, as opposed to other purposes; and even within a unit, the use can vary, depending on the consumer's needs at the time.

Moreover, staff is aware of products that are named and advertised as generic storage products with multiple uses around the house, or they are advertised without context suggesting a particular use. Many of these items clearly share the design features of CSUs, including closed storage behind drawers or doors. In addition, staff is aware of products that appear, based on design, to be CSUs, but are named and advertised for other purposes (*e.g.*, an "accent piece" with drawers staged in a foyer, and large multi-drawer "nightstands" over 27-inches tall). Staff is also aware of hybrid products that combine features of CSUs with features of other product categories; for example,

bookshelf storage products with shelving and closed storage behind drawers or doors; desks or tables with large amounts of attached closed storage; bedroom media furniture with an electronics slot and drawers for clothing; and beds with integrated CSU storage.

Using the criteria in the proposed definition of a CSU, products typical of shelving units, office furniture, dining room furniture, laundry hampers, built-in units, and single-compartment closed rigid boxes likely would not be CSUs. The proposed rule excludes these products, by including in the definition of "CSUs" that a CSU is freestanding; has a minimum closed storage functional volume greater than 1.3-cubic feet; and a closed storage functional volume greater than the sum of the open storage functional volume and open space volume; has drawer(s) and/or door(s); and is reasonably expected to be used for clothing. Staff assesses that some underbed drawer storage units, occasional/accent furniture, and nightstands could be CSUs. The criteria for identifying a CSU in the proposed rule would keep some of these products within scope, and exclude others, depending on their closed storage, reasonable expected use, and the presence of doors/drawers, such that those products that may be used as CSUs and present the same hazard, would be within the scope of the standard, while those that would not, would be excluded.

Because consumers select units for clothing storage based on their utility, not necessarily their marketing, and there are products that are not named or advertised as CSUs, but are indistinguishable from CSUs, based on their design, the proposed scope and CSU definition do not rely on how a product is named or advertised by a manufacturer.

#### f. Number of Drawers

CPSC also considered including, as an element of the proposed CSU definition, the number of drawers in the unit, but did not ultimately do so. The FMG CSU use study (Tab Q of the NPR briefing package) examined how consumers define CSUs and what they use to store clothing in their homes. Focus group participants defined CSUs as anything that can hold clothing; dressers, closets, and armoires were the most common example product categories that participants provided. Participants said that CSUs are used "for organization and the protection of clothing (*e.g.*, drawers of various sizes, dividers to help with organization, and doors to keep clothing out of sight)." Researchers

reported that “the majority of participants reported that they generally think of a CSU as having at least three drawers. However, a few participants noted that a CSU could have four drawers, whereas others mentioned that, to be considered a CSU, a unit only needed one drawer. Participants often considered a unit with two drawers or fewer to be a nightstand.” Because of the varied perceptions about the number of drawers for a unit to be considered or used as a CSU, CPSC did not include this as an element of the definition.

#### g. Overall Size and Storage Volume

Apart from the functional volume of closed storage, which is included in the proposed CSU definition, CPSC also considered the overall size of units as a potential element of the CSU definition, but did not ultimately include this.

In the FMG CSU focus groups (Tab Q of the NPR briefing package), participants discussed how the size of a unit influenced their perception of whether a unit is a CSU. Researchers found: “[t]he majority of participants noted that if a unit is too small, they will not store clothing in it, because the clothing will not fit”; however, participant’s perception of “too small” varied. Researchers found: “a few participants noted that CSUs in their children’s room are smaller than their typical definitions. The units are shorter so that their children can more easily access drawers, and drawers are smaller to fit smaller clothing.” Although there was no consensus on drawer size for a CSU, participants preferred “to have drawers that are large enough (e.g., bigger than a shirt) and deep enough to hold clothing.” They also showed flexibility on drawer volume: “[o]ne participant mentioned that there is a difference between what they would ideally like in terms of drawer size and what they will accept.” They said ideally, they would like drawers deep enough to easily store clothing; however, participants noted that the current dresser they have requires them to shove or stuff their clothing inside. Furthermore, the specific size of the drawers was reported to vary, based on the needs of each person and the size of the home.

The minimum drawer size that could reasonably accommodate clothing is fairly small. For example, the functional volume of each drawer of the shortest/lightest reported CSU involved in a nonfatal CSU tip-over incident without a television—a 26-inch-high by 15-inch-deep by 21.25-inch-wide, 2-drawer chest—is slightly less than 0.7 cubic

feet;<sup>87</sup> and the manufacturer states that the drawer holds about 5 pairs of folded pants or 10 t-shirts. Furthermore, except for the extremes (*i.e.*, very short, very narrow, very shallow), the shape of the drawer should not have an effect on the amount of clothing that can be stored in the drawer because clothing can be folded or stuffed to match the drawer dimensions.

Because small units and small drawers can be used to hold clothing, the proposed CSU definition does not include additional requirements for overall size and storage volume.

#### h. Product Weight

CPSC also considered whether to include a weight criterion in the proposed CSU definition, but did not do so. The weight of the CSU was reported for 17 fatal and 25 nonfatal CPSRMS tip-over incidents with a child and no television. The lightest-weight reported CSU involved in a fatal tip-over incident without a television was a 5-drawer CSU with the bottom 3 drawers missing, which tipped over on a 2-year-old child. The unit weighed 34 pounds without the 3 drawers, the configuration at the time of the incident. The lightest weight reported, non-modified CSU involved in a fatal tip-over incident without a television was a 57 pound, 3-drawer chest, which tipped over onto a 2-year-old child.<sup>88</sup> Other fatal incidents involving light-weight CSUs include a 57.5 pound, 4-drawer wicker dresser without a television that tipped over onto an 18-month-old child and a 68-pound, 3-drawer chest that tipped over in three separate fatal incidents without televisions, resulting in the death of a 23-month-old child, and two 2-year-old children.

The reported lightest weight CSU involved in a nonfatal incident without a television is a 31-pound, 2-drawer chest, which tipped over and pinned a 13-month-old child.<sup>89</sup> In another nonfatal incident with no television, a 45-pound, 3-drawer chest tipped onto a 3-year-old child.

Staff is aware of some lightweight plastic units marketed and used as

<sup>87</sup> The drawers of the current model of the product are 12½ inches deep x 13¾-inch-wide, and the clearance height is 7¼ inches. The functional drawer volume of each drawer is 0.69 cubic feet, using the equation in Tab L of the NPR briefing package; the total functional drawer volume for the 2-drawer CSU is 1.38 cubic feet.

<sup>88</sup> This is the same unit as the shortest known CSU involved in a fatal tip-over incident involving a child and CSU without a television.

<sup>89</sup> This is the same unit, identified by the consumer as a “nightstand,” but marketed as a “chest,” as the shortest known CSU involved in a nonfatal tip-over incident involving a child and CSU without a television.

CSUs.<sup>90</sup> Staff found many lightweight frame and drawer units marketed online as CSUs. Staff also found many online videos showing consumers using lightweight plastic units to store children’s clothing. In addition, one of the participants in the CSU use study said they used a plastic stackable drawer unit to store children’s clothing. Based on this information, consumers will perceive and use lightweight units as CSUs.

With an assumed clothing load of 8.5 pounds per cubic foot of storage volume, many lightweight units could be filled to the same weight as the incident-involved units. The 34-pound unit referenced above had minimal clothing in it, and the 57-pound unit was reportedly empty at the time of the fatal incident. Staff did not identify any tip-over incidents involving plastic units in the fatal and nonfatal CPSRMS data involving children without a television; however, staff cautions that in 64 fatal and 20 nonfatal incidents, model names were not obtained and could have included plastic units.

Because consumers will perceive and use lightweight units as CSUs, and it is possible to fill lightweight units with clothing loads that exceed the lowest product weights seen in the incident data, these units are included in the proposed rule.

### B. Stability Requirements

#### 1. Proposed Requirements

The proposed requirements for stability of CSUs consist of configuring the CSU for testing, performing testing using a prescribed procedure, and determining whether the performance results comply with the criteria for passing the standard.

To configure the CSU for testing, the proposed rule requires the CSU to be placed on a hard, level, flat surface, which the standard defines. If the CSU has a levelling device, the device is adjusted to the lowest level and then according to the manufacturer’s instructions. The CSU is then tipped forward 1.5 degrees, and if there is a levelling device intended for a carpeted surface, the device is adjusted in accordance with the manufacturer’s instructions for a carpeted surface.

All doors (as defined in the standard) are then open to a specified position and fill weights are placed in drawers and pull-out shelves, depending on

<sup>90</sup> For this analysis, staff only considered lightweight units with drawers and/or doors. Staff is also aware that consumers use storage bins with lids to store clothing; however, staff does not consider these to be CSUs, based on the proposed definition.

whether there are interlocks on the unit. Because the test configuration differs, depending on the presence of interlocks, the proposed rule requires testing the interlocks before conducting the stability testing.

The interlock testing consists of placing the CSU on a hard, level, flat surface (as defined in the standard), levelling according to manufacturer instructions, securing the unit to prevent sliding or tip over, and opening the number of drawers necessary to engage the interlock. A 30-pound horizontal pull force is then applied on each locked drawer, one at a time, over a period of 5 seconds, and held for at least 10 seconds. This pull test is repeated until all possible combinations of drawers have been tested. If any locked drawer opens or the interlock is damaged, during this testing, then the interlock is to be disabled or bypassed for the stability testing.

For the stability testing, for units without an interlock or that did not pass the interlock test, all drawers and pull-out shelves are open to their maximum extension (as defined in the standard), and a fill weight of 8.5 pounds per cubic foot times the functional volume (in cubic feet) is placed in the center of each drawer or pull-out shelf. For units with an interlock that passed the interlock test, all drawers that are not locked by the interlock are open to the maximum extension (as defined in the standard), in the configuration most likely to cause a tip over (typically the largest drawers in the highest position open). If 50 percent or more of the drawers and pull-out shelves by functional volume are open, a fill weight is placed in the center of each drawer or pull-out shelf, including those that remain closed. The fill weight is 8.5 pounds per cubic foot times the functional volume (cubic feet). If less than 50 percent of the drawers and pull-out shelves by functional volume are open, no fill weight is placed in any drawers or pull-out shelves.

The proposed rule provides two test methods for the tip-over test. Test Method 1 is most appropriate for CSUs with drawers or pull-out shelves. It involves applying a vertical force to the face of the uppermost extended drawer or pull-out shelf to cause the unit to tip over (defined as the point at which a CSU pivots forward such that the rear feet (or edge) lifts at least  $\frac{1}{4}$  inch from the floor or is supported by a non-support element). At that point, the tip-over moment of the unit is calculated by multiplying the tip-over force (as defined in the standard) by the horizontal distance from the force application point to the fulcrum (as

defined in the standard). If a drawer breaks during the test due to the force, Test Method 2 should be used or the drawer can be secured or reinforced, as long as the modifications do not increase the tip-over moment.

Test Method 2 is appropriate for any CSU. It involves applying a horizontal force to the back of the CSU orthogonal (*i.e.*, at a right angle) to the fulcrum to cause the unit to tip over. The tip-over moment is then calculated by multiplying the tip-over force by the vertical distance from the force application point to the fulcrum.

Once the tip-over moment for the CSU has been determined, that value must be greater than several comparison moments, as applicable, depending on the design of the CSU. The first comparison moment applies to CSUs with drawers or pull-out shelves and is 55.3 pounds times the drawer or pull-out shelf extension from the fulcrum distance (as defined in the standard), plus 26.6 pounds feet. The second comparison moment is for units with doors and is 51.2 pounds times the door extension from fulcrum distance (as defined in the standard, in feet), minus 12.8. The third comparison moment applies to all CSUs and is 17.2 pounds times the maximum handhold height (as defined in the standard, in feet). The greatest of these three comparison tip-over moments is considered the threshold moment, which the tested CSU's tip-over moment must exceed.

## 2. Basis for Proposed Requirements

As described in this preamble and the NPR briefing package, there are several factors that are commonly involved in CSU tip-over incidents that contribute to the instability of CSUs, and a number of these factors often occur simultaneously. These include multiple open and filled drawers, carpeting, and forces generated by children's interactions with the CSU (such as climbing and opening/pulling on drawers). The proposed rule includes requirements to simulate or account for all of these factors, in order to accurately assess the stability of CSUs during real-world use.

The stability testing in the proposed rule simulates these factors simultaneously (*e.g.*, all drawers open and filled, on carpet, and accounting for child interaction forces). This is because incident data indicate that these factors commonly exist at the same time. For example, incidents include children climbing on open drawers, filled with clothing.

### a. Multiple Open and Filled Drawers

As discussed in section IV.C. Hazard Characteristics, opening drawers of a CSU was a common interaction in CSU tip overs involving children and only a CSU. It was the most common reported interaction (63 percent) in nonfatal CPSRMS incidents; it was the second most common reported interaction (8 percent) in nonfatal NEISS incidents; and it was the third most common reported interaction (9 percent) in fatal CPSRMS incidents. Children as young as 11 months were involved in incidents where the child was opening one or more drawers of the CSU, and the incidents commonly involved 2- and 3-year-olds. In numerous incidents, the children opened multiple or all of the drawers. The youngest child reported to have opened all drawers was 13 months old.

The incident analysis also indicates that, of the CSU tip overs involving children and only CSUs for which the reports indicated the contents of the CSU, 96 percent of fatal CPSRMS incidents involved partially filled or full drawers; and 90 percent of the nonfatal CPSRMS incidents involved partially filled or full drawers. Most items in the drawers were clothing.

As this preamble explains, opening extendable elements (drawers, doors, pull-out shelves) shifts the CG towards the front of the CSU, and the closer the CG is to the front leg, the easier it is to tip forward if a force is applied to the drawer. Therefore, CSUs will tip more easily as more drawers are opened. The CG of a CSU will also change depending on the position and amount of clothing in each drawer. Closed drawers filled with clothing tend to stabilize a CSU, but as each filled drawer is pulled out, the CG of the CSU will further shift towards the front. Staff's testing demonstrates this principle, finding that multiple open drawers decrease the stability of a CSU, and filled drawers further decrease stability when more than half of the drawers by volume are open, but increase stability when more than half of the drawers by volume are closed.

Taken together, this information indicates that children commonly open multiple filled drawers simultaneously during CSU tip-over incidents, and that doing so decreases the stability of the CSU if half or more of the drawers by volume are open. Accordingly, the proposed rule includes multiple open and filled drawers as part of the unit configuration for stability testing, and varies whether drawers are filled depending on how many of the drawers

and pull-out shelves can open, as determined by an interlock system.

As staff testing showed, when all CSU drawers are pulled out and filled, the unit is more unstable. However, when CSU drawers have interlocks or other means that prevent more than half the drawers by volume from being pulled out simultaneously, the CSU tips more easily with all drawers empty. Accordingly, when an interlock or other means prevents more than half the drawers and pull-out shelves by interior volume from being opened simultaneously, the proposed rule requires that no fill weight be placed in the drawers.

Although fewer incidents involved CSUs with doors, those incidents indicate that children opened the doors of the CSU. Moreover, in many CSUs with doors, the doors must be open to access the drawers. Given these considerations, and that opening doors makes a CSU less stable, the proposed rule also requires doors to be open during stability testing.

#### i. Fill Density

As discussed in section VII.A. Multiple Open and Filled Drawers, staff assessed the appropriate method for simulating CSU drawers that are partially filled or fully filled (Tab L of the NPR briefing package). To do this, staff looked at the standard that ASTM considered (8.5 pounds per cubic foot) and the results of the Kids in Danger and Shane's Foundation study<sup>91</sup> (which found an average density of 8.9 pounds per cubic foot). To assess whether the 8.5 pounds per-cubic-foot measure reasonably represents the weight of clothing in a drawer, CPSC staff conducted testing with folded and unfolded children's clothing on drawers of different sizes. For all three drawer sizes, staff was able to fit 8.5 pounds per cubic foot of unfolded and folded clothing fill in the drawers. When the clothing was folded and unfolded, the clothing fully filled the drawers, but still allowed the drawer to close. The maximum unfolded clothing fill density was slightly higher than 8.5 pounds per cubic foot for all tested drawers; and the maximum unfolded clothing fill density ranged from 8.56 to 8.87 pounds per cubic foot, depending on the drawer. The maximum folded clothing fill density ranged from 9.40 to 10.16 pounds per cubic foot, depending on the drawer.

Based on this testing, staff found that 8.5 pounds per cubic foot of clothing

will fill a drawer. This amount of clothing is less than the absolute maximum amount of clothing that can be put into a drawer, especially if the clothing is folded, however, the maximum amount of unfolded clothing that could be put into the tested drawers was only slightly higher than 8.5 pounds per cubic foot. Although staff achieved a clothing density as high as 10.16 pounds per cubic foot with folded clothing, consumers may be unlikely to fill a drawer to this level because it requires careful folding, and it is difficult to remove and replace individual pieces of clothing. On balance, CPSC considers 8.5 pounds per cubic foot of functional drawer volume a reasonable approximation of the weight of clothing in a fully filled drawer.

Because CSUs are reasonably likely to be used to store clothing, and incident data indicates that CSUs involved in tip-over incidents commonly include drawers filled with clothing, the proposed rule requires 8.5 pounds per cubic foot as fill weight when more than half of the drawers by volume are open.

#### ii. Interlocks

Because the fill level, as well as the stability of a CSU, depends on how many drawers can open, the standard also includes a requirement that the interlock system withstand a 30-pound horizontal pull force. Without such a requirement, consumers may be able to disengage the interlock, or the interlock may break, resulting in more filled drawers being open during real-world use, and less stability, than assessed during stability testing.

Staff assessed the pull strength of children to determine an appropriate pull force requirement for the interlock test (and the comparison moment for pulling open a CSU), and found that the mean pulling strength of 2- to 5-year-old children on a convex knob (diameter 40 mm) at their elbow height is 59.65 Newton (13.4 pound-force) for males and 76.43 Newton (17.2 pound-force) for females.<sup>92</sup> In the study from which staff drew these values, participants were asked to exert their maximum strength at all times, described as the highest force they could exert without causing injury. Participants were instructed to build up to their maximum strength in the first few seconds, and to maintain maximum strength for an additional few seconds. Participants were instructed to use their dominant hand. Based on this, children between

2 and 5 years old can achieve a mean pull force of 17.2 pounds. ANSI/SOHO S6.5 includes a slightly higher horizontal pull force of 30-pounds in its stability requirements. To ensure that the standard adequately assesses the integrity of interlock systems, the proposed rule includes a 30-pound horizontal pull force.

#### iii. Maximum Extension

The proposed rule requires that all extension elements—including drawers, doors, and pull-out shelves—be opened to the maximum extension and least-stable configuration. The proposed rule defines maximum extension. The general conceptual framework is that all drawers are opened fully, or if there is an interlock, the worst-case drawers that can be opened at the same time are opened fully. Maximum extension for drawers and pull-out shelves is the furthest manufacturer recommended use position, as indicated by way of a stop; if there are multiple stops, they are open to the stop that allows the furthest extension; if there is no stop, they are open to  $\frac{2}{3}$  of the shortest internal length of the drawer or  $\frac{2}{3}$  of the length of the pull-out shelf.

#### b. Carpeting

As discussed in section IV.C. Hazard Characteristics, of the fatal CPSRMS tip-over incidents involving children and only CSUs that reported the type of flooring the CSU was on, 82 percent involved carpeting. Of the incidents that provided photos, the carpet was typical wall-to-wall carpet, with most being cut pile, and a few being looped pile. Of the nonfatal CPSRMS tip-over incidents involving children and only CSUs that reported the type of flooring, 80 percent involved carpeting. Thus, for incidents where flooring type was reported, carpet was by far the most prevalent flooring type.

As discussed earlier, staff testing showed that CSUs with a variety of designs and stability levels were more stable on a hard flooring surface than they were on carpeting. Consistent with incident data, staff used wall-to-wall carpet for this testing and tested the CSU stability with various configurations of open and filled drawers. For 94 percent of the comparison weights (including multiple variations of open and filled drawers), the units were more stable on the hard surface than on carpet, with a mean difference in tip weight of 7.6 pounds.

Therefore, based on incident data and testing, CSUs are commonly on carpet during CSU tip-over incidents, and carpet increases the instability of the CSU. Accordingly, the proposed rule

<sup>91</sup> Kids in Danger and Shane's Foundation (2016). Dresser Testing Protocol and Data. Data set provided to CPSC staff by Kids in Danger, January 29, 2021.

<sup>92</sup> DTI (2000). Strength Data for Design Safety—Phase 1 (DTI/URN 00/1070). London: Department of Trade and Industry.

includes a requirement that simulates the effect of carpet in order to accurately mimic real-world factors that contribute to CSU instability. To determine how to simulate the effect of carpet, section VII.C. Flooring explains that staff compared the tip weights of CSUs on carpet with the tip weights for the same units when tilted forward to various degrees on a hard, level, flat surface. Staff found that the tip weight of CSUs on carpet corresponded with tilting the CSUs forward 0.8 to 3 degrees, depending on the CSU, with the mean tilt angle that corresponded to the CSU tip weights on carpet being 1.48 degrees. Therefore, a forward tilt of 1.5 degrees replicates the effect of carpet on CSU stability, and this is included in the CSU configuration requirements for the stability testing in the proposed rule.

#### c. Test Methods

The proposed rule provides two test methods for applying force to a CSU to determine its tip-over moment. The first test method involves applying a vertical load to the top surface of a fully extended drawer on the CSU; the second test method involves applying a horizontal load to the rear of the CSU, causing it to tip forward. Based on staff's testing (Tab M of the NPR briefing package), these methods produce approximately equal tip-over moments. For this reason, the proposed rule allows either test method to be used. However, because the first test method requires the use of a drawer, the proposed rule specifies that the first test method is appropriate for such products. The second test involves applying force to the back of a CSU and, as such, it can be used for any design.

Both test methods require the location of the fulcrum to be determined and the distance from the open drawer face to the fulcrum to be measured. Intuitively, the fulcrum is located at the front of the bottom-most surface of the CSU.<sup>93</sup> This is the point or line about which the CSU pivots when it tips forward. Therefore, the proposed rule defines the fulcrum as the bottom point or line of the CSU touching the ground about which the CSU pivots when a tip-over force is applied. The fulcrum is typically located at the line connecting the front feet. However, for CSUs without feet, or for CSUs with an irregular pattern of

feet, the fulcrum may be in a different location. Some CSUs may have multiple fulcrums that will vary, depending on the direction the tip-over force is applied. The fulcrum that results in the smallest tip-over moment should be determined. If testers choose to use a horizontal load, the load should be applied such that the tip-over moment is minimized (typically orthogonal to the fulcrum). For this reason, the proposed rule requires the horizontal force to be applied to the back of the unit orthogonal to the fulcrum.

#### d. Performance Requirements

##### i. Pass-Fail Criteria

Once the tip-over moment has been calculated using one of the methods above, the proposed rule specifies that the tip-over moment of the CSU must be greater than several comparison tip-over moments (the greatest of which is considered the threshold moment). These comparison tip-over moments determine whether the tip-over moment of the CSU is sufficient to withstand tipping over when child interactions identified in incidents and measured by UMTRI occur. Staff developed three pass-fail criteria based on three child interactions that can lead to CSU tip-over incidents. The first interaction is a child climbing (ascending) a CSU; the second is a child pulling on a handhold of a CSU while opening or attempting to open a drawer; and the third is a child climbing (hanging) on the door of a CSU.

Staff expects that the comparison tip-over moment for ascending the CSU will be the most onerous requirement for most CSUs. However, some CSUs with particular geometric features, or without drawers, may have greater tip-over moments associated with the alternative criteria, based on children's interactions with the CSU.

##### ii. Climbing

As described earlier in this preamble, of the fatal CPSRMS tip-over incidents involving children and only a CSU that reported the type of interaction, 74 percent involved a child climbing on the CSU. Climbing was the most common reported interaction for children 3 years old and younger. Of the nonfatal CPSRMS tip-over incidents involving children and only a CSU that reported the type of interaction, 20 percent involved a child climbing on the CSU. Of the nonfatal NEISS CSU tip-over incidents involving children and only CSUs that reported the type of interaction the child was engaged in, 77 percent involved climbing on the CSU. For children 3 years old or younger,

climbing constituted almost 80 percent of reported interactions. Overall, 81 percent of the reported interactions in the nonfatal NEISS tip-over incidents involving children and only CSUs are those in which the child's weight was supported by the CSU (e.g., climbing, in drawer, jump, on top, swinging). Thus, in fatal and nonfatal incidents, a child climbing on the CSU was one of the most common reported interactions.

Of climbing incidents with a reported age, the children were 3 years old or younger in 94 percent of the fatal CPSRMS incidents; 73 percent of the nonfatal NEISS incidents; and 60 percent of the nonfatal CPSRMS incidents. Climbing behavior is consistent with expected motor development of children this age.

CPSC staff's analyses of tip-over incidents in Tab M of the NPR briefing package outline several scenarios where children climbing or interacting with the front of a CSU caused the CSU to tip over. In some of the scenarios, the force on the edge of an open drawer associated with tipping the CSU was greater than the static weight of a child standing on the edge of an open drawer of the CSU. The equivalent force consists of the child's weight, the dynamic force on the edge of the drawer due to climbing, and the effects of the child's CG extending beyond the edge of the drawer. Based on the UMTRI study, staff estimated the equivalent force to be more than 1.6 times the weight of the child for typical drawer extensions. Therefore, these tip-over incidents occurred because the forces and moments associated with children climbing on a CSU exceeded the static body weight of a child standing on the edge of an open drawer.

Staff determined that the ascend interaction from the UMTRI child climbing study was the most representative of a child climbing interaction seen in the incident data. As discussed in Tab D of the NPR briefing package, based on the UMTRI study of child climbing behaviors (Tab R of the NPR briefing package), ascent can be described by the following equation:

$$M = \{1.08 [\text{Fulcrum } X \text{ (ft)}] + 0.52 \text{ ft}\} \times \text{Weight of Child (lb)}$$

In this equation, Fulcrum X is the horizontal distance from the front of the extended drawer to the fulcrum.

In the UMTRI study, other measured climbing interactions involving climbing into drawers and climbing onto the tabletop generated lower moments than ascent; thus, they are included within performance requirements based on ascent.

Because most climbing incidents involved children 3 years old and

<sup>93</sup> For CSUs with circular pads on the feet, CPSC staff typically found higher numerical correlation between test results and numerical analysis when the tip-over fulcrum in the calculation was placed at the center of the pads on the front feet (rather than the front of the pads). The difference between the two results was small. Staff does not consider foot pad geometry a significant factor in determining the tip-over moment of a CSU.

younger, the proposed rule uses the 95th percentile weight of 3-year-old children (51.2 pounds) in this equation to generate the first comparison tip-over moment. The 95th percentile weight of 3-year-old boys is 51.2 pounds and the 95th percentile weight of 3-year-old girls is 42.5 pounds.<sup>94</sup> To address the heaviest of these children, the proposed rule uses 51.2 pounds. Moreover, as described earlier in this preamble, this is consistent with the weight of children involved in tip-over incidents, particularly for climbing incidents, when known, or when estimated by their age.

Based on these considerations, to pass the moment requirement for a child ascending a CSU, the tip-over moment ( $M_{tip}$ ) of the CSU must meet the following criterion:  $M_{tip} \text{ (lb-ft)} > 51.2 (1.08X + 0.52)$ , where X is the horizontal distance (in feet) from the front of the extended drawer to the fulcrum.<sup>95</sup> Simplified, this is  $M_{tip} \text{ (lb-ft)} > 55.3X + 26.6$ .

CPSC staff calculates that CSUs that meet a requirement based on the climbing force generated by a 51.2-pound child, and that considers the effects of all drawers (or doors) open and drawers filled, plus the effect of carpet on stability, likely will protect 95 percent of 3-year-old boys by weight and more than 95 percent of 3-year-old girls, and virtually all younger children. For example, with the proposed test requirements, virtually all climbing incidents are presumably addressable involving 2-year-old children because they are all well under 51.2 pounds (95th percentile 2-year-old boys weigh 38.8 pounds and girls weigh 34.7 pounds). This requirement would also protect more than 90 percent of 4-year-old boys and 95 percent of 4-year-old girls who also engaged in this climbing scenario. This testing would protect 75 percent of 5-year-old boys and more than 50 percent of 5-year-old girls. It would also protect 50 percent of 6-year-old children; 25 percent of 7-year-old children; and 7.1 percent of 8-year-old children.

Overall, staff calculates that 91.2 percent of all nonfatal NEISS incidents involving climbing interactions are likely to be addressed with the proposed rule. Staff notes that this number is a

<sup>94</sup> Fryar, C.D., Carroll, M.D., Gu, Q., Afful, J., Ogden, C.L. (2021). Anthropometric reference data for children and adults: United States, 2015–2018. National Center for Health Statistics. Vital Health Stat 3(46). Three years of age covers children who are at least 36 months old and under 48 months old.

<sup>95</sup> For a CSU without drawers, X is measured from the fulcrum to the front edge of the farthest extended element, excluding doors. If the CSU has no extension elements (other than doors), X is measured from the fulcrum to the front of the CSU.

low estimate, because it assumes that all climbing incidents occurred with all open and filled drawers on CSUs located on a carpeted surface, which is a worst-case stability condition.

### iii. Opening Drawers

As described in this preamble, of the fatal CPSRMS tip-over incidents involving children and only a CSU that reported the type of interaction, 17 percent involved a child sitting, laying, or standing in an open drawer, and 9 percent involved a child opening drawers. Of the nonfatal CPSRMS tip-over incidents involving children and only a CSU that reported the type of interaction, 63 percent involved opening drawers, 6 percent involved putting items in/taking them out of a drawer; 6 percent involved pulling on the CSU; and 3 percent involved leaning or pushing down on an open drawer. Opening drawers was the most common reported interaction for children six years old and younger.

Of the nonfatal NEISS CSU tip-over incidents involving children and only CSUs that reported the type of interaction the child was engaged in, 8 percent involved opening drawers, and 15 percent involved a child in the drawer, pulling on the CSU, putting items in or taking items out of a drawer, reaching, hitting, jumping, a child on top of the CSU, playing in a drawer, pulling up, and swinging. Overall, 12 percent of the reported interactions in the nonfatal NEISS tip-over incidents involving children and only CSUs are those in which the child's strength determines the force (e.g., hit, opening drawers, pulled on, pulled up). Thus, in nonfatal incidents, opening drawers was one of the most common reported interactions.

Moreover, looking at both fatal and nonfatal CPSRMS tip overs involving children and only CSUs, where the interaction involved opening drawers, overall, about 53 percent involved children opening one drawer, 10 percent involved opening two drawers, and almost 17 percent involved opening "multiple" drawers. Children as young as 11 months were involved in incidents where the child was opening one or more drawers of the CSU, and the youngest child reported to have opened all drawers was 13 months old. Incidents involving opening drawers most commonly involved children 3 years old and younger.

As discussed earlier, it is possible for CSUs to tip over from the forces generated by open drawers and their contents, alone, without additional interaction forces. However, pulling on a drawer to open it applies an increased

force that contributes to instability. The moment generated with a horizontal force is higher as the location of the force application gets farther from the floor. Therefore, the proposed rule includes as the second required comparison tip-over moment, the moment associated with a child pulling horizontally on the CSU at the top reachable extension element handhold within the overhead reach dimension of a 95th percentile 3-year-old. This is because children 3 years old and younger are most commonly involved in these incidents.

The proposed rule applies the horizontal pull force to the top of an extended drawer in the top row of drawers, or to another potential handhold, that is less than or equal to 4.12 feet high (49.44 inches). The 4.12-foot height limit is based on the overhead reach height for a 95th percentile 3-year-old male; the proposed rule uses the overhead reach height of 3-year-olds because most children involved in opening drawer incidents were 3 years old or younger.<sup>96</sup> Consistent with this overhead reach height, staff's analysis of 15 incidents shows that the highest pull location was 46 inches from the floor.<sup>97</sup>

The proposed rule includes a 17.2 pound-force of horizontal pull force. This pull force is based on the mean pull strength of 2- to 5-year-old females exerted at elbow level on a convex knob. The mean pulling strength of 2- to 5-year-old females is 76.43 Newton (17.2 pound-force), and 59.65 Newton (13.4 pound-force) for males.<sup>98</sup> In the study that provided these pull strengths, participants were 2 to 5 years old, and the mean participant weight was 16.3 kilograms (36 pounds). Participants were asked to exert their maximum strength at all times, described as the highest force they could exert without causing injury, using their dominant hand. Participants were instructed to build up to their maximum strength in the first few seconds, and to maintain maximum strength for an additional few seconds.

The proposed rule uses this 17.2 pound-force pull strength because, in the study, females had a higher mean strength than males, and these incidents

<sup>96</sup> Pheasant, S. (1986). Bodyspace Anthropometry, Ergonomics & Design. London: Taylor & Francis.

<sup>97</sup> Staff assessed 15 child incidents in which the height of the force application could be calculated based on descriptions of the incidents. Force application heights ranged from less than one foot to almost four feet (46.5 inches), and children pulled on the lowest, highest, and drawers in between.

<sup>98</sup> DTI, Strength Data for Design Safety—Phase 1 (DTI/URN 00/1070). London: Department of Trade and Industry. (2000).

most commonly involve children 3 years old and younger. The weight of children in the study (36 pounds) is over the 50th percentile weight of 3-year-old children. Therefore, the pull force test requirement will address drawer opening and pulling on CSU incidents for 50 percent of 3-year-olds, 95 percent of 2-year-olds, 100 percent of children under 2 years, 25 percent of 4-year-olds, 10 percent of 5-year-olds, and will not address these incidents for children 6 years old and older.

Based on this 17.2-pound horizontal force on a handhold at a height of up to 4.12 feet, the moment created by this interaction can be described with the equation  $M$  (lb-ft) = 17.2 (lb)  $\times$   $Z$  (ft), where  $Z$  is the vertical distance (in feet) from the fulcrum to the highest handhold that is less than or equal to 4.12 feet high. Using this equation, the tip-over moment of the CSU in the second comparison value in the proposed rule is  $M_{tip}$  (lb-ft) > 17.2 $Z$ .

#### iv. Climbing on Doors

As discussed in IV. Risk of Injury, two fatal CPSRMS and four nonfatal CPSRMS tip-over incidents involved wardrobes and armoires, which include doors. In most of these incidents, children were interacting with things inside the CSU, indicating that the doors were open. The ages of the children in these incidents ranged from 3 to 11 years, although opening doors is easily within the physical and cognitive abilities of younger children. Once CSU doors are open, children are capable of putting their body weight on the open doors (*i.e.*, open and climbing/hanging), provided the child has a sufficient hand hold. For this reason, the third comparison tip-over moment in the proposed rule represents the force from a 95th percentile 3-year-old child hanging on an open door of the CSU.

UMTRI researchers found that the vertical forces associated with children hanging by the hands were close to the body weight of the child (Figure 48 in Tab R of the NPR briefing package). For this reason, the third comparison tip-over moment, representing a child hanging on an open door, uses the weight of a 95th percentile 3-year-old child, or 51.2 pounds. Staff considers the weight placement location for testing doors in ASTM F2057–19 (section 7.2) reasonable. Therefore, the proposed rule uses the test location from the voluntary standard, which is approximately half the width of the test fixture, or 3 inches, from the edge of the door, to obtain the equation describing a 95th percentile weight 3-year-old child hanging from an open door of a CSU:  $M$  (lb-ft) = 51.2 (lb)  $\times$  [ $Y - 0.25$  (ft)],

where  $Y$  is the horizontal distance (in feet) from the fulcrum to the edge of the door in its most extended position. Based on this equation, the tip-over moment of a CSU with doors must meet the following criterion:  $M_{tip}$  (lb-ft) > 51.2( $Y - 0.25$ ). Simplified, this is  $M_{tip}$  (lb-ft) > 51.2 $Y - 12.8$ .

#### v. Additional Interactions

For the reasons described above, the proposed rule focuses on the interactions of children climbing on and opening CSUs. Although other plausible climbing-associated behaviors (*e.g.*, yank, lean, bounce, one hand) included in the UMTRI study generated higher moments, there was no direct evidence of these interactions in the incident data. However, depending on the child's age, weight, and strength, some of these interactions could be addressable with the proposed performance requirements. Other measured climbing interactions, for example, including hop up, hang, in drawer, and climbing onto the tabletop, generated lower moments than ascent. Similarly, staff expects that putting items in/taking items out of a drawer, reaching, pulling up, and hitting the CSU (all indicated in the incident data) would also generate lower moments than those included in the proposed rule. As such, these additional interactions are addressed by the proposed performance requirements. In addition, staff evaluated each of the seven incidents involving children jumping, falling from the top of the CSU, or swinging, considering the possible moment and reported age of the child and determined that five of the seven would be addressed by the proposed rule.

Although the proposed rule focuses on addressing the CSU tip-over hazard to children, improving the stability of CSUs should also reduce a substantial portion of the incidents involving adults. This is because a majority of the incidents involved consumers interacting with the CSU by opening drawers and/or getting items in and out of drawers, or leaning on the CSU, all scenarios that are expected to be less than or equally severe compared to incidents of children climbing with all drawers filled and opened.

### C. Marking and Labeling

#### 1. Proposed Requirements

The proposed rule includes requirements for a warning label. The proposed warning label requirements address the size, content, symbol, and format of the label. The proposed warning statements address the CSU tip-over hazard, and how to avoid it. They

indicate that children have died from furniture tipping over, and direct consumers how to reduce the risk of tip overs, by securing furniture to the wall; not allowing children to stand, climb, or hang on units; not defeating interlock systems (if the unit has them); placing heavier items in lower drawers; and not putting a television on CSUs (when the manufacturer indicates they are not designed for that purpose). The proposed format, font, font size, and color requirements incorporate by reference the provisions in ASTM F2057–19. The proposed rule also includes requirements for the location of the warning label, addressing placement in drawers or doors, and the height of the label in the unit. The proposed rule also requires the warning label to be legible and attached after it is tested using the methods specified in ASTM F2057–19.

The proposed rule also includes requirements for an informational label. It requires the label to include the name and address of the manufacturer, distributor, or retailer; the model number; the month and year of manufacture; and state that the product complies with the proposed rule. There are size, content, format, location, and permanency requirements as well. The label must be visible from the back of the unit when the unit is fully assembled, and must be legible and attached after it is tested using the methods specified in ASTM F2057–19.

#### 2. Basis for Proposed Requirements

##### a. Warning Requirements, Generally

The proposed rule requires a warning label to inform consumers of the hazard and motivate them to install tip restraints as a secondary safety mechanism. However, there are limitations to the effectiveness of warning labels to address the risk of CSU tip overs. Risk perception is greatly influenced by product familiarity, hazardousness of the product, likelihood of injury, and severity of injury. Risk perception is also influenced by people's beliefs about their ability to control the hazard and whether they believe the warning message. An inherent problem with CSUs and the tip-over hazard is that people are less likely to recognize potential hazards associated with products that they use more frequently. CSUs are products with high familiarity because they are found in most households, and consumers are likely to interact with them daily.

Therefore, even well-designed warnings have limited effectiveness in changing a CSU user's behavior. In

addition, although the warning may impact adult behavior, children would not read or comprehend the warnings.

#### b. Warning Label Placement

In the FMG CSU use study (Tab Q of the NPR briefing package), researchers evaluated warning labels in in-home interviews and focus groups. They found that participants indicated that they had not paid attention to or noticed warning labels on the units in their children's rooms, even when the researchers noted they were present. Participants also indicated that, even if they had seen a warning label on a CSU, they probably would not pay attention to it. Focus group participants identified the following as potential locations where a warning label could be seen easily and be more likely to grab their attention: top of the unit in the corner, on the handle of a unit, inside the top drawer of a unit, and in the instruction manual. Participants said the back of the unit was not an acceptable place for the warning label because it would not be visible. Participants also expressed that they would remove labels that were too conspicuous (*e.g.*, on the outside or top of a unit).

An effective warning label must be visible and noticeable, and it must capture and maintain consumers' attention. The proposed rule requires the warning label to be placed in the uppermost clothing storage drawer or in one drawer in the uppermost row that is entirely below 56 inches, which is the 5th percentile standing eye height of women in the United States.<sup>99</sup> This is consistent with the information CPSC obtained from the FMG study, regarding placement of warnings.

#### c. Warning Label Content

After noticing a warning label, consumers must read the message, comprehend the message, and decide whether the message is consistent with their beliefs and attitudes. In addition, consumers must be motivated enough to spend the effort to comply with the warning-directed safe behavior. Warnings should allow for customization of hazard avoidance statements based on unit design, to reflect incident data (*e.g.*, television use). Similarly, the warning text should be understandable, not contradict typical CSU use, and be expressed in a

way that motivates consumers to comply.

In the FMG CSU use study, focus group participants evaluated the ASTM F2057–19 warning label text. Participants had mixed opinions about the statement: "Children have died from furniture tip over." Some participants found it motivating, others believed that it was hyperbole and seemed likely to disregard it. The majority of participants said that they do not follow the instruction to install a tip restraint, especially if the tip restraint is not included with the CSU. Participants wanted more information about why they should not put a television on a CSU, and some thought consumers would disregard the warning if putting a television on top of a CSU fit their needs. A majority of participants said that they open more than one drawer at a time, and that children typically open one or two drawers. Participants believed that placing the heaviest items in the lowest drawers was common sense, and was a warning they would follow.

Based on this information, the proposed warning label includes warnings about the hazard, television use (where appropriate for the product), and placing heavier items in lower drawers, but does not include a statement to not open multiple drawers because that is inconsistent with consumer use. In addition, the proposed tip-restraint warning explicitly directs the consumer to secure the CSU to the wall and uses a term for tip restraint that consumers will likely understand. "Tipover restraint," used in ASTM F2057–19, might confuse some consumers because restraints generally describe what they contain (*e.g.*, child restraint), rather than what they prevent. Terminology such as "anti-tip device" is clearer.

#### a. Warning Label Format and Style

The proposed rule requires the warning label to be at least 2 inches wide by 2 inches tall. This size is consistent with the required content and format for the label, and it ensures that the label is not too narrow or short.

The proposed rule also requires the child climbing symbol that is ASTM F2057–19. However, as discussed in section VII.G. Warning Label Symbols, if one of the two variants being considered performs better in comprehension testing than the ASTM F2057–19 child climbing symbol, the Commission may consider requiring one of those variants in the final rule. The proposed rule also requires the ASTM F2057–19 no television symbol for CSUs that are not designed to hold a television.

CPSC staff regularly uses ANSI Z535.4, *American National Standard for Product Safety Signs and Labels*—the primary U.S. voluntary consensus standard for the design, application, use, and placement of on-product warning labels—when developing or assessing the adequacy of warning labels. The proposed rule uses the warning format in ASTM F2057–19, which is consistent with ANSI Z535.4.

To be effective, a warning label must remain present. Label permanency requirements are intended to prevent the warning label from being removed inadvertently and to provide resistance to purposeful removal by the consumer. CPSC staff evaluated the ASTM F2057–19 label permanency requirements (Tab F of the NPR briefing package) and concluded that they are adequate. Accordingly, the proposed rule includes the permanency testing prescribed in ASTM F2057–19.

#### b. Informational Label

Staff was able to identify the manufacturer and model of CSU associated with only 22 of the 89 fatal CPSRMS incidents involving children and CSUs without televisions<sup>100</sup> and 230 of the 263 nonfatal CPSRMS incidents involving children and CSUs without televisions. In the case of recalls, consumers must be able to identify whether their CSU is subject to the recall and is potentially unsafe. Accordingly, an identification label that provides the model, manufacturer information, date of manufacture, and a statement of compliance with the proposed rule is important to facilitate identification and removal of potentially unsafe CSUs. This label would also allow for easier identification of compliant and noncompliant CSUs by consumers and CPSC, and would provide information that would assist in identifying the CSU, allowing staff to assess more easily hazards associated with specific designs.

The proposed rule requires the informational label to be at least 2-inches wide by 1-inch tall, which is consistent with the required content and format, and ensures that the label is not too narrow or short. The proposed rule requires text size that is consistent with ANSI Z535.4. The proposed rule requires the identification label to be visible from the back of the unit when the unit is fully assembled because it is not necessary for the label to be visible to the consumer during normal use, but it should be visible to anyone inspecting the unit. In addition, the proposed rule

<sup>100</sup> An additional CSU was identified as handmade.

<sup>99</sup> Nesteruk, H.E.J. (2017). Human Factors Analysis of Clothing Storage Unit Tipover Incidents and Hazard Communication. In Staff Briefing Package Advance Notice of Proposed Rulemaking: Clothing Storage Units. Available at: <https://www.cpsc.gov/s3fs-public/ANPR%20-%20Clothing%20Storage%20Unit%20Tip%20Overs%20-%20November%2015%202017.pdf>.



requires permanency testing prescribed in ASTM F2057–19 to increase the likelihood that the label remains attached to the CSU.

#### D. Hang Tags

##### 1. Proposed Requirements

As discussed above, section 27(e) of the CPSA authorizes the Commission to issue a rule to require manufacturers of consumer products to provide “such performance and technical data related to performance and safety as may be required to carry out the purposes of [the CPSA].” 15 U.S.C. 2076(e). The Commission may require manufacturers to provide this information to the Commission or, at the time of original purchase, to prospective purchasers and the first purchaser for purposes other than resale, as necessary to carry out the purposes of the CPSA. *Id.*

The proposed rule sets out requirements for providing performance and technical data related to performance and safety to consumers at the time of original purchase and to the first purchaser of the CSU (other than resale) in the form of a hang tag. The hang tag provides a stability rating, displayed on a scale of 0 to 5, that is based on the ratio of tip-over moment (as determined in the testing required in the proposed rule) to the minimally allowed tip-over moment (provided in the proposed rule). The proposed rule includes size, content, icon, and format requirements for the hang tag. It also includes a requirement that the hang tag be attached to the CSU and clearly visible to a person standing in front of the unit; that lost or damaged hang tags must be replaced such that they are attached and provided, as required by the rule; and that the hang tags may be removed only by the first purchaser. In addition, the proposed rule includes placement requirements that the hang tag appear on the product and the immediate container of the product in which the product is normally offered for sale at retail; that for ready-to-assemble furniture, the hang tag must appear on the main panel of consumer-level packaging; and that any units shipped directly to consumers shall contain the hang tag on the immediate container of the product. For a detailed description of the proposed regulatory text.

##### 2. Basis for Proposed Requirements

###### a. Purpose

Consistent with the requirements in section 27(e) of the CPSA, the proposed hang tag requirements help carry out the purpose of the CPSA by “assisting

consumers in evaluating the comparative safety of consumer products.” 15 U.S.C. 2051(b)(2). The proposed rule would require CSUs to meet a minimum level of stability (*i.e.*, exceed a threshold tip-over moment). However, above that minimum level, CSUs may have varying levels of stability. A hang tag provided on the CSU would offer consumers comparative information about the stability of products, based on the tip-testing protocol in the proposed rule. By providing product information at the point of purchase, the hang tag would inform consumers who are evaluating the comparative safety of different CSUs and making buying decisions. This information may also improve consumer safety by incentivizing manufacturers to produce CSUs with higher levels of stability, to better compete in the market, thereby increasing the overall stability of CSUs on the market.

###### b. Background

CPSC based the formatting and information requirements in the proposed hang tag on work CPSC has done previously to develop performance and technical data requirements,<sup>101</sup> as well as the work of other federal agencies that require comparative safety information on products.<sup>102</sup> As part of CPSC’s development of a similar requirement for recreational off-highway vehicles (ROVs), CPSC issued a contract for cognitive interviews and focus group evaluation to refine the proposed ROV hang tag. The contractor developed recommendations regarding the content, format, size, style, and rating scale, based on consumer feedback during this work.<sup>103</sup>

Studies on the usefulness and comprehension of point-of-sale product information intended to help consumers evaluate products and make buying decisions support the effectiveness of hang tags, and linear scale graphs, in particular. For example, a study on the EnergyGuide label for appliances, which also uses a linear scale, indicated that the label increased consumer awareness

<sup>101</sup> *E.g.*, 16 CFR 1401.5, 1402.4, 1404.4, 1406.4, 1407.3, and 1420.3.

<sup>102</sup> *E.g.*, the Federal Trade Commission’s EnergyGuide label for appliances in 16 CFR part 305, requiring information about capacity and estimated annual operating costs; and the National Highway Traffic Safety Administration’s New Car Assessment Program star-rating for automobiles, providing comparative information on vehicle crashworthiness.

<sup>103</sup> EurekaFacts, LLC, *Evaluation of Recreational Off-Highway (ROV) Vehicle Hangtag: Cognitive Interview and Focus Group Testing Final Report* (Aug. 31, 2015), available at: <https://www.cpsc.gov/s3fs-public/pdfs/ROVHangtagEvaluationReport.pdf>.

of energy efficiency as an important purchasing criterion.<sup>104</sup>

###### c. Specific Elements of the Proposed Requirements

One element of the proposed hang tag is a symbol depicting a CSU tipping over. This symbol identifies the product and hazard. Research studies have found that warning labels with pictorial symbols are more noticeable to consumers.<sup>105</sup> To allow consumers to identify exactly what product the label describes, the proposed hang tag requires the manufacturer’s name and the model number of the unit. The proposed requirement also includes text to explain the importance of the graph, and the significance and meaning of the tip-over resistance value of the CSU. The proposed graph indicates the minimally acceptable tip rating, which is 1,<sup>106</sup> so that consumers can evaluate the extent to which the rating of a particular CSU meets or exceeds the minimal permissible rating. In addition, the proposal requires the front of the hang tag to be yellow, to increase the likelihood consumers attend to the tag, and also consistent with EurekaFacts research recommendations (discussed below) and the EnergyGuide hang tag for household appliances, which is “process yellow.”

The performance criteria in the proposed stability requirement requires the tested moment of a CSU to be greater than a calculated threshold moment requirement. The tip rating number on the hang tag is the ratio of tested moment to threshold requirement. This provides a simple calculation that results in a number greater than 1,<sup>107</sup> which can be easily represented on a scale. Additionally, due to the nature of a ratio, a rating of 2 means the unit can withstand twice the threshold moment, a rating of 3 is three times the threshold moment, and so forth. As an example: Unit A has an acceptable moment of 10 ft-lbs. When A is tested, the test engineer finds it tips at 25 ft-lbs. Unit

<sup>104</sup> National Research Council. *Shopping for Safety: Providing Consumer Automotive Safety Information—Special Report 248*. Washington, DC: The National Academies Press (1996).

<sup>105</sup> Wogalter, M., Dejoy, D., Laughery, K., *Warnings and Risk Communication*. Philadelphia, PA: Taylor & Francis, Inc. (1999).

<sup>106</sup> The minimally acceptable rating is just above 1 because the tested moment of a CSU must be greater than the threshold moment, however, for simplicity, the proposed hang tag marks the minimally acceptable rating as 1.

<sup>107</sup> The equation is  $\text{Moment}_{\text{tested}} / \text{Moment}_{\text{threshold}}$ . If  $\text{Moment}_{\text{tested}} = \text{Moment}_{\text{threshold}}$ , then  $\text{Moment}_{\text{tested}} / \text{Moment}_{\text{threshold}} = 1$ . But the proposed performance requirement is that  $\text{Moment}_{\text{tested}} > \text{Moment}_{\text{threshold}}$ . Therefore, all units must have a ratio greater than 1, although it may be only a small fraction over 1.

A's ratio is 25:10, for a rating of 2.5. Unit B also has an acceptable moment of 10 ft-lbs. Testing on Unit B found it tipped at 50 ft-lbs. Unit B's ratio is 50:10, or a rating of 5. Unit C has an acceptable moment of 5 ft-lbs. Testing on Unit C found it tipped at 20 ft-lbs. Its ratio is 20:5, or a rating of 4. Therefore, Unit A is 2.5 times more stable than required; Unit B is 5 times more stable than required; and Unit C is 4 times more stable than required. Also, unit B is twice as stable as unit A. Unit C lies between units A and B in terms of stability.

Because the linear scale on the proposed hang tag is a graphical representation of the stability information, it is important to include labels so that consumers understand the data on the tag. To make clear the meaning of the information on the linear scale, CPSC staff placed the label "high" at the right side of the scale to identify for the consumer that the higher value equates to better stability or higher tip-over resistance. The proposed hang tag also includes a technical explanation of the graph and rating to explain how to interpret and use the graphic and number.

When EurekaFacts conducted research on CPSC's proposed ROV hang tag, focus group participants preferred to have whole numbers anchoring the scale, such as 1 to 10, to communicate comparative information. CPSC staff testing suggests that, although few CSUs currently meet the proposed requirement, many CSUs on the market today would achieve ratings between 1 and 2, with appropriate modifications. Therefore, using a 10-point scale may be difficult for consumers to differentiate between units. To minimize this difficulty, the proposed requirement uses a 5-point scale. CPSC expects that, over time, there may be units with a broader range of scores (beyond the current 1 and 2), as consumers desire more stable units, and manufacturers build more stable units. Although some units theoretically could have a normalized value over 5, representing this as a 5, or the highest point on the scale, would be reasonably interpreted by consumers as a high stability. If, in the future, many CSUs exceed 5, the Commission can revisit the scale.

In the proposed rule, the scale begins at 0. EurekaFacts found focus group participants preferred whole numbers as anchor points on the scale range and expressed confusion with decimals. Zero is lower than the minimal acceptable rating of 1 to provide a common anchor point in consumers' mental models of a scale, and the whole numbers allow for better relative

comparisons. In addition, allowing the display of a rating lower than the requirement allows simple identification that CSUs at least meet the minimum requirement.

Research has shown that pictorial symbols and icons make warnings more noticeable and easier to detect than warnings without such symbols and icons.<sup>108</sup> Additionally, including a graphic before introducing text may serve as a valuable reference for consumers, by maintaining attention and encouraging further reading.<sup>109</sup> For these reasons, the proposed hang tag requirement includes a symbol of a CSU at a slight angle to identify the product and tipping characteristics. In addition, presenting information both graphically and textually offers a better chance of comprehension by a wide range of users, such as non-English-literate users.

The size, placement, and attachment specifications in the proposed hang tag requirement are consistent with the recommendations by EurekaFacts and similar requirements in other standards. The EurekaFacts report found that participants preferred hang tags to be large because they were more noticeable and easier to read. In addition, participants preferred a vertical orientation. Based on this information, the proposed hang tag must be 5-inches wide by 7-inches tall.

Consistent with similar standards, the proposed hang tag provision requires the tag to be provided at the time of original purchase, that it be replaced if lost or damaged, that it appear on the product and packaging, that it be clearly visible to a person standing in front of the unit, and that it be removable only with deliberate effort. These requirements facilitate the tag staying on the product so that consumers see and use the information on the hang tag when making purchasing decisions.

Because the proposed stability performance criteria are based on moments, which are not easily understood forces, CPSC expects that some consumers may wish to better understand the information provided. For this reason, the reverse side of the hang tag provides additional information about the test used to calculate the stability rating on the front of the hang tag and what the rating means. The required font sizes are intended to facilitate ease of reading.

<sup>108</sup> Wogalter, M., Dejoy, D., Laughery, K. (1999). *Warnings and Risk Communication*. Philadelphia, PA: Taylor & Francis, Inc.

<sup>109</sup> Smith, T.P. (2003). *Developing consumer product instructions*. Washington, DC: U.S. Consumer Product Safety Commission.

## E. Prohibited Stockpiling

### 1. Proposed Requirements

As explained earlier in this preamble, section 9(g)(2) of the CPSA allows the Commission to prohibit manufacturers of a consumer product from stockpiling products subject to a consumer product safety rule to prevent manufacturers from circumventing the purpose of the rule. 15 U.S.C. 2058(g)(2). The proposed rule prohibits manufacturers and importers of CSUs from manufacturing or importing CSUs that do not comply with the requirements of the proposed rule in any 1-month period between the date a rule is promulgated and the effective date of the rule at a rate that is greater than 105 percent of the rate at which they manufactured or imported CSUs during the base period for the manufacturer. The proposed rule defines the base period as the calendar month with the median manufacturing or import volume within the last 13 months immediately preceding the month of promulgation of the final rule.

### 2. Basis for Proposed Requirements

The proposed stockpiling limit is intended to allow manufacturers and importers sufficient flexibility to meet normal levels and fluctuations in demand for CSUs, while limiting their ability to stockpile large quantities of CSUs that do not comply with the rule for sale after the effective date. Because most firms will need to modify their CSUs to comply with the proposed requirements, and the modifications may be costly, CPSC believes it is appropriate to prevent stockpiling of noncompliant products.

## IX. Preliminary Regulatory Analysis<sup>110</sup>

The Commission is proposing to issue a rule under sections 7 and 9 of the CPSA. The CPSA requires that the Commission prepare a preliminary regulatory analysis and that the preliminary regulatory analysis be published with the text of the proposed rule. 15 U.S.C. 2058(c). The following discussion is extracted from staff's memorandum, "Draft Preliminary Regulatory Analysis of the Proposed Clothing Storage Unit Stability Rule," available in Tab H of the NPR briefing package.

### A. Preliminary Description of Potential Costs and Benefits of the Proposed Rule

The preliminary regulatory analysis must include a description of the potential benefits and potential costs of the proposed rule. The benefits of the

<sup>110</sup> Further detail regarding the preliminary regulatory analysis is available in Tab H of the NPR briefing package.

rule are measured as the expected reduction in the societal costs of deaths and injuries that would result from adoption of the proposed rule and any benefits that cannot be quantified. The costs of the rule are defined as the added costs associated with modifying CSUs to comply with the requirements of the rule, including any impacts on the utility of the CSUs for consumers, as well as any costs that cannot be quantified.

*Deaths and Injuries Related to Tip Overs of CSUs.* CPSC identified 179 deaths related to CSU tip-over incidents involving children that occurred from 2001 through 2016.<sup>111</sup> This results in an average of 11.2 deaths per year over this 16-year period. These are the deaths associated with CSU tip-over incidents of which CPSC staff is aware. The actual number of deaths from CSU tip-over deaths during this period could be higher.

Ninety-seven of the 179 deaths also involved television sets that had been placed on top of the CSU. Of the 97 deaths involving televisions, 80 (82 percent) involved older, heavy CRT televisions, and only one of the deaths is known to have involved a flat-screen television. The older CRT televisions are usually substantially heavier than the newer flat-screen televisions, which may pose more serious injuries during a tip over, and may shift the center of gravity of the CSU forward, making it less stable. Based on this, as the number of CRT televisions in use decreases, staff expects the number of tip-over incidents and their severity to decrease. In 2010, about 55 percent of all televisions in use were CRT televisions. By 2020, that percentage was expected to be about 9 percent; and it is expected to decline to less than 1 percent by 2030. Thus, incidents involving CRT televisions are not considered in the main analysis. Considering only those cases for which staff know that a CRT television was not involved, there were 99 fatalities (179 deaths less 80 that involved a CRT television) during the 16-year period, or an average of 6.2 per year.

Although the proposed standard is intended to address CSU fatalities involving children, during the same period from 2001 through 2016, there were 29 fatalities involving adults and CSUs tipping over, or an average of 1.8 a year. Fourteen of these victims were

age 80 years or older, and none were younger than 40. It is possible that some of these or similar deaths could have been prevented had the CSUs involved met the stability requirements of the proposed rule.

Based on NEISS, there were an estimated 14,900 nonfatal injuries to children involving CSU tip overs during the 5-year period from 2015 through 2019 that were treated in hospital EDs. About 2,300 of these estimated injuries (16 percent) involved televisions that had been placed on top of the CSUs. However, staff is not making any adjustments for nonfatal injuries that also involved a television set because there is generally less information available about the nonfatal injuries than for the fatality cases, making it more difficult to determine if the television involved was a CRT or a flat screen.

In addition to injuries initially treated in hospital EDs, many product-related injuries are treated in other medical settings, such as physicians' offices, clinics, and ambulatory surgery centers. Some injuries also result in direct hospital admission, bypassing the hospital ED entirely. The number of CSU-related injuries treated outside of hospital EDs can be estimated with the CPSC's Injury Cost Model (ICM), which uses empirical relationships between the characteristics of injuries (diagnosis and body part) and victims (age and sex) initially treated in hospital EDs and the characteristics of those initially treated in other settings.

The ICM estimate of injuries treated outside of hospitals or hospital EDs (e.g., in doctors' offices, clinics) is based on data from the Medical Expenditure Panel Survey (MEPS). The MEPS is a nationally representative survey of the civilian, non-institutionalized population that quantifies individuals' use of health services and corresponding medical expenditures. To project the number of direct hospital admissions that bypass hospital EDs, the ICM uses data from the Nationwide Inpatient Sample of the Healthcare Cost and Utilization Project (HCUP-NIS). HCUP is a family of healthcare databases and related software tools and products developed through a federal-state-industry partnership and sponsored by the Agency for Healthcare Research and Quality (part of the U.S. Department of Health and Human Services). The HCUP-NIS provides information annually on approximately 3 million to 4 million in-patient stays from about 1,000 hospitals.

Based on the NEISS estimate of 14,900 ED-treated injuries in 2015 through 2019, the ICM projects

approximately 19,300 CSU tip-over injuries treated in other settings during the same 5-year period, or an average of 3,900 per year. Combining the NEISS estimate of injuries treated in hospital EDs with the ICM estimate of medically attended injuries treated in other settings brings the estimate of all nonfatal, medically attended CSU tip-over injuries to children under the age of 18 years to 34,100 during the years 2015 through 2019.

During the same 2015 to 2019 period, there were an estimated 7,000 adults and seniors that were treated in EDs because of injuries received when CSUs tipped over. Although the proposed rule is intended to reduce injuries to children, some portion of the injuries to adults would probably have been prevented had the CSUs involved met the stability requirements of the proposed rule. Based on the NEISS estimate of 7,000 injuries to adults treated in EDs, the ICM projects that there were 15,700 injuries treated in other medical settings, for a total of 22,700 medically attended injuries to adults involving CSU tip overs.

*Societal Costs of Deaths and Injuries.* To estimate the societal costs of CSU-related deaths, staff applied an estimate of the value of statistical life (VSL), an estimate used in benefit-cost analysis to place a value on reductions in the likelihood of premature deaths. For this analysis, staff applied estimates of the VSL developed by the U.S. Environmental Protection Agency (EPA). In 2018 dollars, the EPA estimate of the VSL is about \$9.2 million, suggesting the societal cost of the fatalities is about \$57.0 million annually, if only those deaths to children reported not to involve a CRT television are included ( $6.2 \times \$9.2$  million). If all deaths are included, the societal costs of the fatalities would be \$103.0 million annually ( $\$9.2$  million  $\times$  11.2 deaths per year). The societal cost of the adult fatalities would be \$16.6 million a year ( $1.8$  deaths  $\times$   $\$9.2$  million).

The societal costs of the nonfatal CSU injuries are quantified with the ICM. The ICM is fully integrated with NEISS, and in addition to providing estimates of the societal costs of injuries reported through NEISS, the ICM also estimates the costs of medically treated injuries that are initially treated outside of hospital EDs. The aggregated societal cost components provided by the ICM include medical costs, work losses, and the intangible costs associated with lost quality of life, or pain and suffering.

Information on the societal costs associated with nonfatal CSU injuries to children are presented in Table 2, and

<sup>111</sup> For this preliminary regulatory analysis, staff used the data for 2001 to 2016, rather than the more recent data provided in the full incident data, in order to calculate an annual average. Data collection is ongoing for more recent years. If the data included the years for which data collection is ongoing, the calculated annual average would be low.

the societal costs of the nonfatal injuries to adults are presented in Table 3. The estimates are the average annual costs for the 5-year period from 2015 through 2019. The national estimates of medically attended injuries described above are presented in column 2, and include not only the 3,000 injuries to children initially treated in hospital EDs (1,400 in the case of adults), but also the 3,900 other medically attended injuries

initially treated outside of hospital EDs (3,100 in the case of adults). The estimated injury costs range from about \$15,015 per injury treated in physicians' offices, to about \$34,522 for injuries to patients treated and released from a hospital ED, to about \$323,296 for hospital admitted injuries (averaging the costs associated with those admitted from the ED and those admitted to the hospital bypassing the ED). The average

cost of injuries to adults was slightly lower than the average cost of injuries to children: \$28,344 vs. \$31,757. Altogether, the societal costs of nonfatal injuries to children involving CSUs averaged \$216,747,160 annually, from 2015 through 2019. The cost of injuries to adults averaged \$128,710,471 annually over the same period.

TABLE 2—AVERAGE ANNUAL NONFATAL INJURY COSTS ASSOCIATED WITH CSU TIP OVERS TO CHILDREN UNDER THE AGE OF 18 (2015–2019)

Place of treatment	National estimate	Medical cost	Work loss	Pain and suffering	Average total cost	Total cost
Doctor/Clinic .....	3,804	\$653	\$1,521	\$12,842	\$15,015	\$57,112,589
Emergency Department .....	2,830	2,886	1,767	29,899	34,552	97,786,129
Hospital-Adm Direct .....	53	31,157	105,672	160,347	297,176	15,654,763
Hospital-Adm via ED .....	139	34,371	116,072	182,813	333,256	46,193,679
Average .....	.....	2,499	4,753	24,505	31,757	.....
Total .....	6,825	17,057,479	32,438,983	167,250,698	.....	216,747,160

Source: CPSC Injury Cost Model and NEISS cases involving CSU tip overs for the years 2015 through 2019.

TABLE 3—AVERAGE ANNUAL NONFATAL INJURY COSTS ASSOCIATED WITH CSU TIP OVERS TO ADULTS 18 YEARS OF AGE AND OLDER (2015–2019)

Place of treatment	National estimate	Medical cost	Work loss	Pain and suffering	Average total cost	Total cost
Doctor/Clinic .....	3,094	\$837	\$2,692	\$13,800	\$17,329	\$53,613,046
Emergency Department .....	1,284	2,519	2,516	21,247	26,281	33,731,304
Hospital-Adm Direct .....	37	38,728	72,391	139,589	250,707	9,396,404
Hospital-Adm via ED .....	126	40,739	69,784	142,870	253,393	31,969,717
Average .....	.....	2,734	5,081	20,529	28,344	.....
Total .....	4,541	12,412,977	23,074,265	93,223,230	.....	128,710,471

Source: CPSC Injury Cost Model and NEISS cases involving CSU tip overs for the years 2015 through 2019.

*Potential Benefits of Stability Requirements for CSUs.* The proposed rule would require that the tip-over moment of a CSU, as determined by the method in the proposed standard, exceed the moment that would be produced by a 51.2-pound child climbing up a drawer or hanging on a door, or a child pulling on drawers and doors of the CSU. The following discussion estimates the projected reduction in the societal costs of deaths and injuries under the proposed rule.

Table 4 summarizes the annual societal costs of deaths and injuries by age of the victims. Staff used this information to estimate the anticipated reduction in the societal costs of injuries that can be anticipated if the proposed regulation is finalized. The costs associated with fatalities are based on the fatalities known to CPSC staff that

occurred from 2001 through 2016, and excludes those fatalities in which CRT televisions were known to be involved. Incidents known to involve a CRT television were excluded for the reasons described above, however, cases for which the type of television involved could not be determined were included because some of these incidents might have involved a flat-screen television. The societal costs of nonfatal injuries are based on NEISS cases occurring from 2015 through 2019. No adjustment for the potential involvement of CRT televisions has been made in the nonfatal estimates for the reasons described above.

Given the multiple real-world factors that contribute to tip overs that the proposed rule accounts for, CPSC staff concludes that the proposed rule should prevent CSU tip-over incidents caused

by children climbing up, hanging on, or pulling on drawers and doors of the CSU, provided that the child weighs 51.2 pounds or less. The proposed rule is also expected to prevent other common, but less severe scenarios such as opening drawers without climbing, putting items in and out of drawers, or playing in a drawer. CPSC staff believes that the proposed rule could prevent virtually all of these tip-over incidents involving children who are most at risk and probably many similar incidents involving older children and adult victims. The proposed rule would be less effective in reducing tip overs in some severe, but less common scenarios, such as bouncing and yanking; however, these scenarios were not directly observed in the incident data.

TABLE 4—ANNUAL SOCIETAL COSTS OF INJURIES AND DEATHS BY AGE (MILLIONS OF DOLLARS)

Age (in years)	Fatalities*	Societal cost fatalities	Injuries	Societal cost of nonfatal injuries	Societal costs of injuries and deaths
Less Than 2 .....	2.4	\$22.1	1,039	\$29.3	\$51.4
2 .....	1.9	17.5	1,498	58.7	76.2
3 .....	1.4	12.9	1,346	43.5	56.4
4 .....	0.1	0.9	980	41.1	42.0
5 .....	0.1	0.9	582	13.9	14.8
6 .....	0.1	0.9	532	13.7	14.6
7 .....	0.1	0.9	172	5.7	6.6
8 .....	0.1	0.9	244	2.9	3.8
9 to 17 .....	.....	.....	431	8.1	8.1
Total Children .....	6.2	57.0	6,824	216.9	273.9
18 and Over .....	1.8	16.6	4,541	128.7	145.3
Total .....	8.0	73.6	11,366	345.6	419.2

\* Average fatalities per year from 2001 through 2016.

\*\* Average number of medically attended injuries from 2015 through 2019.

*Benefits from Reduced Fatalities.* A review of the fatal CSU tip-over incidents involving children and used in this analysis found that all of the victims weighed less than 51.2 pounds. Given staff’s conclusion that the proposed requirements would prevent nearly all tip overs involving children who weigh less than 51.2 pounds, staff believes that all of these fatalities could have been prevented if the CSUs involved had complied with these requirements. More than 90 percent of the child fatalities involved children 3 years old or younger. The vast majority of children of this age weigh less than 51.2 pounds. However, there were a few fatalities, an average of about 1 every other year, to older children who could weigh more than 51.2 pounds. Therefore, for purposes of projecting the benefits of the proposed rule, although staff predicts that almost all fatalities involving children 3 years old and younger could be prevented,<sup>112</sup> staff estimates that only about 48 percent of the deaths to children 4 through 8 years old would be prevented. These calculations are based on analysis by the Division of Human Factors staff concerning the potential of the proposed rule to prevent tip-over deaths by age. Therefore, based on the fatalities between 2001 and 2016, staff estimates that, had all CSUs met the requirements of the proposed rule, about 94 percent of the deaths to children could have been prevented, or an average of 5.8 deaths could have been prevented each year. Assuming a VSL of \$9.2 million, the benefit of the proposed rule in terms

<sup>112</sup> Staff assumes that all deaths involving children 2 years old and younger would be prevented and about 95 percent of the deaths involving 3-year-old children would be prevented.

of reduced child deaths could be \$53.4 million annually.

As noted above, there are also an average of 1.8 fatalities to adults each year from CSU tip-over incidents. There is less information available regarding the tip-over incidents involving adults. Many of the available narratives of these incidents suggest that victims were losing their balance and grabbed the CSU in an effort to balance themselves. Although adults weigh more than 51.2 pounds, because the adults were not attempting to climb the CSUs, the full weight of the adult victim was probably not on the CSU when the incident occurred. Moreover, many of the nonfatal cases involved adults interacting with the CSU, by opening drawers, getting items in and out of drawers, or leaning on the CSU. In many cases, these scenarios are expected to be less or equally severe scenarios, compared to children climbing with all drawers filled and opened. Therefore, CPSC staff has concluded that a substantial portion of the CSU tip-over incidents involving adults would be prevented if the stability of the CSUs was improved. Although staff cannot estimate the exact portion of the incidents involving adults that would be prevented, for purposes of attempting to quantify the benefits of the proposed rule, this analysis assumes that the proposed rule would prevent adult tip-over incidents at about one-half the rate that it prevents child tip-over incidents. On average, this is approximately 0.8 adult fatalities prevented annually or a societal benefit of about \$7.4 million annually.<sup>113</sup>

<sup>113</sup> Staff estimates that the proposed rule prevent about 94 percent of the fatalities involving children (5.5 deaths prevented/6.2 total deaths). If the proposed rule prevents adult fatalities at one-

Together, the potential benefits of the proposed rule from reducing fatal tip-over incidents to both adults and children is estimated to be \$60.8 million annually, if all CSUs were to comply with the requirements. This consists of an estimated \$53.4 million from reducing approximately 5.8 child fatalities a year and \$7.4 million from reducing an average of 0.8 adult fatalities a year. Staff emphasizes that the annual benefits would not actually reach this level until most CSUs in use meet the requirements of the proposed rule. Using the historical sales estimates and an estimated average product life of 15 years, CPSC staff estimates that about 463.5 million CSUs were in use in 2017 and 466 million CSUs were in use in 2018. Given that staff estimates there are approximately 460 million CSUs in use, annual sales are about 44 million units, and the average useful life of CSUs is 15 years, it would likely be more than 10 years after such a requirement goes into effect before the annual benefits approach this level.

*Benefits from Reduced Injuries.* To evaluate the effectiveness of the proposed rule in reducing nonfatal injuries, CPSC staff examined 1,463 NEISS records to determine what the child was doing when the tip-over incident occurred. In 925 incidents, it was not possible to determine the interaction involved in the incident. The remaining 538 incidents were reviewed to determine whether it was likely that the proposed rule would have prevented the incident. A summary of staff’s conclusions regarding these incidents is available in Tab H of the NPR briefing package (Table 3), but the following provides key insights.

half this rate, then about 47 percent of the 1.8 annual deaths to adults might be prevented.

Most of the incidents involved a child climbing the CSU—this interaction accounted for 412 incidents (74 percent). Because the proposed rule is intended to prevent furniture tip overs involving children 51.2 pounds or less climbing on CSUs, staff assumed that all of these incidents would be prevented if the victim weighed less than 51.2 pounds. The NEISS record does not include the weight of the victim, so staff used the age of the victims and data on the distribution of weight by age and sex to estimate the number of incidents that the proposed rule might have prevented.

Staff assumed that all incidents involving children 2 years old and younger that involved climbing a CSU would have been prevented by the proposed rule because the 95th percentile weight for boys is only about 75 percent of 51.2 pounds. Therefore, it is safe to conclude that virtually all children 2 years old and younger weigh less than 51.2 pounds and would be protected by the proposed rule. For 3-year-old children, the 95th percentile weight for boys is 51.2 pounds, which means that an estimated 5 percent of 3-year-old boys weigh more than 51.2 pounds and might not be protected by the proposed rule. To account for this, staff assumed that only 95 percent of the incidents involving 3-year-old children would have been prevented by the proposed rule. For 4-year-old children, based on the percentile weights from the CDC, the 90th percentile weight for boys is 49.1 pounds and the 95th percentile weight is greater than 51.2 pounds. For 4-year-old girls, the 95th percentile weight is 50.1 pounds. Based on these percentile weights, staff assumed that 92.5 percent of the climbing-related incidents involving 4-year-old children would have been prevented. Staff followed the same procedure to estimate the percentage of incidents to children ages 5 years through 8 years. For example, for children 6 years old, the 75th percentile weight for both boys and girls is greater than 51.2 pounds. The 50th percentile weights for boys and girls are 50.3 and 48.6 pounds, respectively. Based on these weights, staff estimated that the proposed rule would have prevented 50 percent of the climbing incidents that involved 6-year-old children. Based on the percentile

weights from the CDC, virtually all children 9 years old and older would be expected to weigh more than 51.2 pounds. Therefore, staff cannot be confident that any of the climbing incidents involving children older than 8 years would have been prevented by the proposed rule.

Another 49 tip-over incidents involved children who were reaching into the CSU, or placing items in, or retrieving items from, the CSU. In a few cases, the victim was playing in the bottom drawer of the CSU, or was hit by the CSU when it tipped over. None of these scenarios would be expected to cause as much rotational force on a CSU as climbing a CSU. Staff believes that CSUs that meet the requirements of the proposed rule, which is intended to prevent tip overs in more severe circumstances, would not tip over in these incidents. Therefore, staff believes that all of these incidents would have been prevented by the proposed rule.

A total of 58 incidents involved children pulling on the CSU, or opening drawers. Staff analyzed these incidents based on children’s pull strength ability and determined that 62 percent of these incidents would be prevented by the proposed rule.

Finally, there were 19 incidents that involved activities such as the victim “swinging” on the CSU, jumping from the CSU, and being on top of the CSU. Based on staff’s analysis, staff assumed that 47 percent of these incidents would be prevented by the proposed rule.

Staff considered 22 incidents in which some “other person” caused the tip over as part of the unknown scenarios, because details on “other person” are not available to make an estimate.

In total, staff believes that the proposed rule would have prevented about 87 percent of NEISS tip-over injuries involving children 17 years of age and under, including about 91 percent of the tip-over incidents involving children climbing on CSUs. As Table 2 in Tab H of the NPR briefing package indicates, the average annual societal cost of nonfatal injuries to children from CSU tip-over incidents is about \$216.9 million. If the proposed rule can prevent 87 percent of these injuries, the annual benefit from the

reduction of nonfatal injuries to children would be \$188.7 million.

As with the adult fatality victims, there is less information available on the activities of the adult victims in the nonfatal incidents. In many cases, the narrative in the NEISS record simply contains a statement such as “dresser fell onto hand,” with no description of the interaction. Some narratives indicate that the victim might have grabbed onto the CSU for balance, was falling and hit the CSU, or may have been attempting to move the CSU. Staff also assumes that some CSUs tipped over when the adult was opening drawers to place items in or remove items from the unit, given that these interactions were in some incidents involving children. Given the very limited information on the activities of the adult victims at the time of the tip-over incident, staff does not have a basis for making strong estimates of the number of incidents that would have been prevented by the proposed rule. However, it is reasonable to expect that a rule that requires CSUs to be more stable would reduce nonfatal injuries to adults. In this analysis, staff assumes that nonfatal incidents involving adults would be reduced by half the percentage that nonfatal incidents to children would be reduced. Because staff believes that the proposed rule will reduce nonfatal tip-over injuries to children by 87 percent, staff assumes that nonfatal adult tip-over injuries will decline by 43.5 percent. Because the average annual societal cost of nonfatal tip-over injuries to adults is estimated to be \$128.7, if all CSUs comply with the proposed rule, the societal cost of the injuries would be reduced by \$56.0 million annually.

*Summary of Expected Benefits.* In summary, if the proposed rule is finalized, once all CSUs in use comply with the requirements, staff expects that there will be virtually no fatal tip-over injuries to children 8 years old and under and fatal injuries to adults will be reduced by one half. Staff expects nonfatal injuries to children to be reduced by 83 percent and nonfatal injuries to adults to be reduced by 41.5 percent. The total reduction in societal costs (or benefit from the proposed rule) would be \$305.5 million annually and is summarized in Table 5.

TABLE 5—SUMMARY OF EXPECTED ANNUAL BENEFITS

Description	Current annual number of incidents	Current societal cost (millions)	Expected reduction in incidents	Expected annual benefit (millions)
Child Fatalities .....	6.2	\$57.0	5.8	\$53.4
Adult Fatalities .....	1.8	16.6	0.8	7.4

TABLE 5—SUMMARY OF EXPECTED ANNUAL BENEFITS—Continued

Description	Current annual number of incidents	Current societal cost (millions)	Expected reduction in incidents	Expected annual benefit (millions)
Non-Fatal Child Injuries .....	6,824	216.9	5,937	188.7
Non-Fatal Adult Injuries .....	4,541	128.7	1,975	56.0
Total .....	.....	419.2	.....	305.5

*Benefits Per CSU in Use.* Generally, it is useful to discuss the benefits of a rule on a per-unit basis. This facilitates the comparison of the benefits of a rule to the costs when the costs are also expressed on a per-unit basis. To calculate the benefits of a standard on a per-unit basis, staff divided the estimated annual benefit by the number of units in use during the year. The result is the benefit per unit per year. The present values of expected annual benefits over the expected life of the product are summed to obtain the per-unit benefit. In general, this should include only those injuries that occurred on products that do not meet the requirements of the standard, and divide that number by the units in use that do not meet the standard. In this analysis, however, given that staff has only identified one CSU that would

meet the requirements of the proposed rule without some modifications, staff assumes that all injuries and deaths to children occurred with CSUs that did not meet the requirements of the proposed rule.

Staff estimates that there were 463.5 million CSUs in use in 2017, which because staff is using the NEISS data from 2015 through 2019 to calculate the societal cost of injuries, this is approximately the average number of CSUs in use during the period. Using these estimates, the estimated annual benefit per unit of the proposed rule would be \$0.66. As noted, staff has assumed that the average product life of a CSU is 15 years. However, this includes the generally less expensive ready-to-assemble (RTA) CSUs that might have expected useful lives that are less than 15 years and the generally

more expensive factory-assembled CSUs that could have expected lives greater than 15 years. Assuming the average CSU has a product life of 15 years, benefit per unit of the proposed rule is the present value of the annual benefits per unit summed over the expected 15-year life of a CSU. Table 6 gives the estimated benefits per unit of the proposed rule using the 3 percent and 7 percent discount rates recommended by the Office of Management and Budget in Circular A-4: Regulatory Analysis (Sep. 17, 2003). However, because interest rates have declined significantly since Circular A-4 was issued in 2003, staff also included the undiscounted values. As shown in Table 6, the benefits per unit of the proposed rule range from \$6.01 to \$9.90, depending on the discount rate considered appropriate.

TABLE 6—BENEFITS PER UNIT BY DISCOUNT RATE

Discount rate	Annual benefit/unit	Benefit/unit over the 15-year life of the CSU
Undiscounted .....	\$0.66	\$9.90
3 Percent .....	0.66	7.88
7 Percent .....	0.66	6.01

*Costs Associated with the Proposed Rule.* This section discusses the costs the proposed rule would impose on society. The costs include the costs that would be incurred to redesign and modify CSUs so that they meet the requirements of each of the standards. These costs include the increased cost to manufacture and distribute compliant CSUs. The costs also include the costs and impacts on consumers. These include the cost of additional time to assemble RTA furniture and the loss of utility if certain desired characteristics or styles are no longer available, or if compliant CSUs are less convenient to use. The costs of designing, manufacturing, and distributing compliant CSUs would be initially incurred by the manufacturers and suppliers, but most of these costs would likely be passed on to the consumers via

higher prices. The costs involving the added assembly time for RTA CSUs or the loss of utility because CSUs with certain features or characteristics are no longer available would be borne directly by those consumers who desired CSUs with those characteristics or features.

To ensure that they comply with a mandatory standard, furniture manufacturers must first determine whether their models comply with the standard. This would involve testing their models for compliance. Because a voluntary standard exists, with which staff believes that most CSUs on the market already comply, most manufacturers are probably already conducting stability testing similar to the testing in the proposed rule. Manufacturers would replace their current test methods with the requirements of the proposed rule. Even

though the new tests would include additional steps (e.g., weighting drawers, pull tests on interlock mechanisms, and testing the CSU on a 1.5-degree angle), on a per-unit basis, any increase in the cost of testing due to the proposed rule is likely to be very small, and therefore, the cost of compliance testing will not be considered further in this analysis. Manufacturers would also need to add a stability rating to a hang tag that would be included on each CSU, which would be derived from the testing. Staff expects that the cost of deriving the stability rating and adding the hang tag to each unit would also be small on a per-unit basis and will not be considered further in this analysis.

Additionally, the cost of providing the certificates of conformity would be very low on a per-unit basis. In the case of

CSUs that are children's products, which are thought to constitute a very small portion of the market for CSUs, the cost of the certification testing could be somewhat higher because an accredited third-party testing laboratory would be required to conduct the certification testing.

The number of CSU models currently on the market that would comply with the requirements of the proposed rule is very low. CPSC staff collected and examined 186 CSU models intended to be a representative sample of the available CSUs, and only identified one model that would meet the requirements of the proposed rule without modification. For each model that does not comply with a mandatory standard, manufacturers must decide whether to stop offering that model or modify the model so that it would comply with the standard. If the manufacturer ceases to offer a noncomplying model, the cost of this decision would be the lost utility to the consumer. This cost cannot be quantified, but it would be mitigated to the extent that other CSUs with similar characteristics and features are available that comply with the standard.

*Costs of Potential Modifications to Increase CSU Stability.*<sup>114</sup> CPSC staff tested and analyzed CSUs to identify several ways units could be modified to increase their stability.<sup>115</sup> The modifications staff assessed were: (1) Adding drawer interlock mechanisms to limit the number of drawers that can be opened at one time; (2) reducing the maximum drawer extensions; (3) extending the feet or front edge of the CSU forward; (4) raising the front of the unit; and (5) adding additional counterweight to the CSU. Manufacturers can use combinations of more than one method to increase the stability of a single CSU model.

One potential modification staff evaluated was drawer interlock systems. A drawer interlock system prevents multiple drawers from being open simultaneously. Typically, an interlock allows one drawer in a column of

drawers to be open at a time, while locking or blocking the other drawers from opening, although some interlock systems allow more than one drawer to open at a time. Interlock systems are common in file cabinets, and they are included in some CSUs. An interlock system can improve the stability of a CSU because a CSU is less stable as more of the drawers are opened, causing the weight of the CSU to move forward. By preventing multiple drawers from opening, the CG of the drawers remains behind the tip point and shifts the CSU's CG back, improving its stability.

Based on staff's testing, a drawer interlock system is one of the most effective options to improve stability, raising the tip-over moment of the CSU more than any other modification that staff evaluated. Interlocks were particularly effective at improving instability when paired with other modifications. However, the benefit of interlocks assumes that they are effective and cannot be bypassed.

The cost of a drawer interlock mechanism includes the cost of design, materials, and labor required to manufacture the mechanism. It would also include the cost of warehousing the parts, the logistics involved in getting the parts to the factory floor, and the cost of incorporating the mechanism into the CSU. In the case of an RTA CSU, some of these costs could fall directly on the consumer. The value of the extra time that might be required of a consumer to assemble a CSU with a drawer interlock is another cost of adding a drawer interlock mechanism. Based on information provided by a manufacturer, the cost of adding a drawer interlock mechanism to a CSU would be around \$12. On the assumption that a manufacturer does not have an incentive to provide CPSC with a low estimate, in this analysis, staff are assuming that this could be a high estimate. Nevertheless, if adding an interlock mechanism requires an additional 5 minutes in labor time to assemble the mechanism and incorporate it into the CSU, then the cost could be \$3.34 in labor costs alone. Considering the added cost of materials and the fact that some CSUs could require two mechanisms, or may need new mechanisms to meet their particular needs, a minimum cost for adding a single interlock mechanism could be \$6.00.<sup>116</sup> The cost could be \$12

or more, especially if more than one mechanism were required, or a new design were required.<sup>117</sup>

Another potential modification is to reduce the travel length of drawer extensions, such as with new drawer slides. Reducing the drawer travel decreases the moment arm, which increases stability. When comparing two drawers on the same unit, the force required to tip over the CSU is more for drawers with shorter extensions.

The manufacturing costs of reducing the maximum drawer extensions is low because it does not necessarily require additional parts or labor time. Perhaps the largest cost is the potential impact on consumer utility if it is less convenient to use CSUs with drawers that cannot open as widely. Staff cannot quantify this cost with the information available.

Another potential modification is to extend the front feet of the CSU forward to extend the fulcrum towards the edge of the drawer. This could be done by extending the front feet forward with an attachment or replacement foot, or by attaching a platform to the bottom of the CSU. However, based on staff's testing, for CSUs with poor stability, the extension or platform may need to be long enough that it could introduce a tripping hazard.

The cost of extending the feet or the front edge of the CSU forward can be very low. In some cases, no additional parts would be required, and the only cost would be the time it takes for the manufacturer to make the change in the manufacturing procedure. This would be the case where already-present feet or glides are simply shifted forward an inch or so. In these cases, the cost of shifting the front edge forward could be less than \$1 per unit. In other cases, feet might need to be added or redesigned. If these feet or glides could be used on multiple CSU models, the costs could be up to \$5 per CSU unit.<sup>118</sup> The cost of adding a base to the unit could be more expensive. In addition to the cost of the materials, there would be manufacturing costs to form the material used for the base and attach it to the unit. For RTA manufacturers, adding a base could involve additional costs to redesign the shipping packages to accommodate the base, and could impact the shipping

for private industry manufacturing workers in goods producing industries, published by the Bureau of Labor Statistics (December 2020).

<sup>117</sup> One manufacturer estimated that an interlocking drawer could add \$12 to the cost of a CSU and increase the retail price by as much as \$39.

<sup>118</sup> Cost based on observed prices for furniture feet available on the internet.

<sup>114</sup> Tab D of the NPR briefing package discusses staff's testing and analysis of potential modifications to CSUs to improve stability and comply with the proposed rule.

<sup>115</sup> The purpose of this testing was to assess options manufacturers would have for modifying CSUs to meet the performance requirements in the proposed rule; none of these potential modifications would be requirements. Some of these modifications could be applied to existing CSUs without extensive design changes. Staff did not evaluate structural design changes, such as increasing the depth of the CSU or using lighter materials for drawers because staff could not easily modify existing CSUs to implement these changes. However, such design modifications could also help increase the stability of CSUs.

<sup>116</sup> Staff does not have direct estimates of the additional labor time that would be required to manufacture and add one or two interlock mechanisms to a CSU, but 5 minutes seems like a reasonably low estimate, if much of the work is manual. The cost of 5 minutes of labor is based on the total employer cost for employee compensation



costs. This could add costs significantly over the \$1 to \$5 estimated here.

Another potential option is to raise the front of the CSU to tilt the unit back, thereby making it less likely to tip forward. Tilting the CSU and drawers back increases the distance from the CSU CG location to the fulcrum, and reduces the distance from the fulcrum to the location where the tip force is applied to the CSU. Several existing CSU designs have adjustable front feet to allow for these level adjustments. Currently, manufacturers typically instruct consumers to adjust the feet as necessary to become level on an unlevel surface. Manufacturers could instruct consumers to tilt the CSU back further on carpet, or other surfaces, such that the CSU is not level, but has more resistance to tipping forward. Similar outcomes could be achieved by replacing the front legs with longer legs, or placing an object under them.

However, there are potential issues with this option. While raising the front feet makes tipping the CSU forward more difficult, it also makes tipping the CSU backward less difficult. Additionally, any manual foot adjustment system requires action by consumers to determine the appropriate level, and it risks the CSU not being used as intended by the manufacturer. Raised front legs also may not be practical on CSUs that are intended to have a level top surface.

According to one manufacturer, leveling devices could cost \$5 per CSU. Observed retail prices for leveling devices can be as little as 30 cents each (at least two would be required for a CSU). If the front of a CSU must be raised a significant amount, other changes might be required to the CSU to keep the top and drawers of the CSU relatively level. The full cost of such changes cannot be quantified with the information available.

The final potential modification staff evaluated was adding additional weight to the CSU. Currently, the back of many CSUs is a thin sheet of fiberboard or other light material. A heavier material could be substituted. Alternatively, manufacturers could add weights to the back or other sections of the CSU to increase stability. Depending on the amount of weight added, there could be an unquantifiable cost to consumers, due to the added weight that they must manage in assembling and moving the CSU. Based on retail prices observed on July 2, 2020, medium-density fiberboard costs approximately \$0.24 per pound, which is a starting point for estimating the additional cost of adding weight to

the back of a CSU.<sup>119</sup> If the additional weight required is low, it could be the only additional cost, because the heavier material would replace a lighter material, and the manufacturing process would require minimal changes. In the case where the added weight that would be required is significant, the costs could be higher, because attaching the back to the CSU could require different hardware, the reinforcement of the sides of the CSU, or different manufacturing procedures might be required to manipulate the heavier weight (*e.g.*, an additional worker or machine to handle the heavier board). In the case of RTA furniture, the cost of packaging and shipping could increase, and there would be an unquantifiable cost to the consumer in the form of the need to handle more weight. Potentially, manufacturers could offset the additional weight by using lower-density or thinner materials for other components, such as drawer fronts or cabinet tops. The Commission requests comments on the cost and other impacts of adding weight to the rear of the CSU to meet the requirements of the proposed rule.

*Annual Cost of the Proposed Rule.* Of the potential modifications for which staff was able to estimate the potential cost, the lowest costs were about \$5.80 per unit. Several were significantly higher. Even assuming the low cost of about \$5.80 per unit, assuming annual sales of at least 43 million units, the annual cost of the proposed rule would be around \$250 million.

*Other Impacts on Consumers.* The costs discussed above are the costs to manufacture CSUs that could comply with the proposed rule. Even where staff has used retail prices to estimate the costs, the retail price was used in an attempt to capture other costs that would be incurred by manufacturers, including the logistics of acquiring the parts, getting them to the factory floor, and the labor involved in installing them; or in the case of RTA CSUs, the costs of packaging the added parts and the cost to consumers, in time and trouble, of installing the added parts. The change in retail prices due to these costs could be greater if manufacturers, wholesalers, and retailers add a markup to their costs. Markups can vary among manufacturers and subsets of the

market, but can be 2 to 4 times the cost to the manufacturer. However, it is not certain that the retail prices would increase from the proposed rule by the same factor. It is possible that competition among manufacturers and different models could prevent retail prices from rising by the usual mark-up over cost.

Some manufacturers may withdraw some CSU models from the market if the cost or difficulty of modifying the models to meet the requirements of the proposed rule are too great in relation to their expected sales. For a small and light CSU, the modifications required could be so substantial that the model no longer has the character of the original model and is simply withdrawn from the market. Consumers who desired those particular models would suffer an unquantifiable loss, which is mitigated to the extent that other CSUs exist that are reasonable substitutes. If the CSU models that are withdrawn are disproportionately the lower-cost models, which are likely to include many lighter and RTA models, the proposed rule could disproportionately impact lower-income consumers or those seeking low-cost models. These consumers might keep using their older, non-compliant CSUs, purchase a previously owned CSU, or even choose other products for clothes storage in place of CSUs, such as shelving, boxes, or storage bins. Although these impacts would be costs associated with the proposed rule, they are not quantifiable.

*General Conclusions.* Staff found that the societal costs of deaths and injuries from CSU tip-over incidents is about \$419.2 million annually. This includes injuries to children and adults and is based on known fatalities from 2001 through 2016, and NEISS injuries from 2015 through 2019. If all CSUs had met the requirements of the proposed rule, however, the societal cost of these incidents would have been reduced by \$305.5 million annually. This then would be the estimated benefit of the proposed rule. On a per-CSU-in-use basis, the benefit estimate is \$0.66 cents per unit annually. Assuming CSUs have an expected useful life of 15 years, the average benefit of the proposed rule would be \$6.01 per unit, assuming a 7 percent discount rate, \$7.88 assuming a 3 percent discount rate, and \$9.90 without discounting.

The costs of the proposed rule highly depend on the actual modifications that are required for CSUs to comply with the rule. The costs would be higher for some models than for others. In some cases, the required modifications could change the character of a CSU model to

<sup>119</sup>Furniture manufacturers presumably would be able to obtain materials at less than retail prices. However, staff used retail prices in this analysis because, as noted above, there would be costs involved, for which staff does not have estimates, in forming and handling the heavier material. In the absence of estimates for these costs, staff believes that using the retail prices would provide a better estimate of the cost to manufacturers of using heavier materials.

the extent that it is not viable and will be withdrawn from the market.

In its analysis, staff used the cost to modify existing CSUs in ways that would allow them to comply with the proposed rule as a measure of the cost of manufacturing CSUs that would comply with the proposed rule. The estimates used in the analysis are reasonable approximations of the costs involved, but in some instances, they could be underestimates because they do not include all of the expected monetary costs (e.g., the costs that would be associated with an interlock system that has not yet been developed), and they do not consider the nonmonetary cost to consumers of the added weight, the decreased maximum drawer extensions, or similar losses associated with the other modifications. Potentially, there could be lower cost options for modifying CSUs to meet the requirements not considered in the analysis. CPSC welcomes comments on any other potential options for modifying or manufacturing CSUs to meet the requirements of the proposed rule.

**Sensitivity Analysis.** Staff's analysis depends on certain estimates and assumptions. In conducting the analysis, staff used values that it believed best reflected reality. However, in many cases, the basis was weak or lacked strong empirical evidence. To address this, staff examined how other reasonable assumptions could affect the results of the analysis. A description of staff's sensitivity analysis is available in Tab H of the NPR briefing package.

#### B. Reasons for Not Relying on a Voluntary Standard

No standard, or statement of intention to modify or develop a standard, was submitted to the Commission in response to the ANPR. However, staff did evaluate existing standards relevant to CSU tip overs and determined that these standards would not adequately reduce the risk of injury associated with CSU tip overs because they do not account for the real-world factors staff identified in CSU tip-over incidents that contribute to instability, including multiple open and filled drawers, children's interactions with the CSU (such as climbing and opening drawers), or carpeting. A detailed discussion of these standards, and why staff considers them inadequate, is in section V. Relevant Existing Standards.

With respect to the primary standard in the United States that addresses CSU tip overs—ASTM F2057—CPSC staff has worked with ASTM on this standard since its inception in 2000, but has not been successful, to date, in revising the

standard to account for the relevant factors. For these reasons, the Commission is not relying on an existing standard.

#### C. Alternatives to the Proposed Rule

CPSC considered several alternatives to the proposed rule. These alternatives, their potential costs and benefits, and the reasons CPSC did not select them, are described in detail in section XI. Alternatives to the Proposed Rule, below, and Tab H of the NPR briefing package.

#### X. Response to Comments<sup>120</sup>

This section describes the comments CPSC received on the ANPR, and responds to them. CPSC received 18 comments during the ANPR comment period, as well as 5 additional correspondences after the comment period, which staff also considered. The comments are available on: [www.regulations.gov](http://www.regulations.gov), by searching under docket number CPSC-2017-0044.

##### A. Voluntary Standards

**Comment:** Several commenters expressed support for ASTM F2057 and felt the voluntary standard process would create a robust standard. Other commenters stated that a mandatory standard is necessary to address the hazard, citing incident data and numerous flaws with ASTM F2057 and ASTM F3096.

**Response:** ASTM F2057 does not account for forces associated with the weight of clothing in filled drawers, the impact of multiple open and filled drawers, children's interactions with CSUs (such as climbing), or CSUs placed on carpet, all of which contribute to instability. Incident reports show that incidents often combine these variables (e.g., a child opening multiple filled drawers and climbing, or a child standing on an open drawer of a unit placed on carpet). The UMTRI child climbing study shows that children climbing can impart rotational forces (tip moments) on CSUs beyond the forces of the child's weight alone. CPSC staff has worked closely with the ASTM F15.42 committee to improve the voluntary standard; staff has attempted and continues to attempt to help revise the ASTM standard to reflect these additional factors that contribute to instability, but, to date, has been unsuccessful.

The proposed rule focuses on inherent stability of CSUs, rather than tip restraints, because the current rate of

tip restraint use is low, and staff has identified several factors that make it unlikely that consumers will use tip restraints. Given this, staff did not evaluate ASTM F3096 in detail for this proposed rule because, even if it was effective at ensuring the strength of tip restraints, low rates of consumer use make tip restraints an ineffective way to address the hazard. However, based on a limited review of ASTM F3096, staff shares the commenters' concerns that ASTM F3096-14 may not be adequate because: (1) The assumed forces may be too low to represent forces from children's interactions, and (2) the standard does not address the whole tip-restraint system, which includes the connection to the CSU and the connection to the wall.

**Comments:** Some commenters provided test data regarding compliance with ASTM F2057, or commented on these reports. One commenter submitted data sets indicating that about 20 to 23 percent of the CSUs it tested did not comply with the voluntary standard.<sup>121</sup> Another commenter's report contained test data for dressers and chests, indicating that more than half of the tested units did not comply with the voluntary standard.<sup>122</sup>

**Response:** CPSC staff conducted a market survey of 188 CSUs purchased in 2018 and found that 91 percent met the stability requirements in ASTM F2057-17, which has the same stability requirements and test methods as F2057-19 (Tab N of the NPR briefing package). Since publication of the ANPR, CPSC has issued 20 recalls for CSUs that did not comply with the ASTM F2057 stability requirements. However, regardless of compliance levels, CPSC considers ASTM F2057-19 inadequate to address the hazard of CSU tip overs.

##### B. Hazard Communication: Warnings and Public Awareness

**Comments:** Several commenters supported the use of hazard communication, including the labeling requirement in ASTM F2057, displaying the warning as a handout at furniture stores, and mandating labeling

<sup>121</sup> This testing assessed compliance with then-current ASTM F2057-17. ASTM F2057-17 included the same stability requirements as ASTM F2057-19, except that F2057-17 applied to units more than 30 inches in height; whereas, F2057-19 applies to units 27 inches or taller. Some of the tested units were 27 to 30 inches tall.

<sup>122</sup> This testing assessed compliance with ASTM F2057-14. ASTM F2057-14 included the same stability requirements as ASTM F2057-19, except that F2057-14 applied to units more than 30 inches in height; whereas, F2057-19 applies to units 27 inches or taller. One of the tested units was 27 to 30 inches tall.

<sup>120</sup> For more details about the comments CPSC received on the ANPR, and CPSC's response to them, see Tab K of the NPR briefing package.

provisions that are “effective, seen, understood, reflect real world use,” and “accurately and clearly describe hazard patterns.” One commenter advocated for education campaigns to educate parents about the hazard and promote the use of tip restraints. Other commenters indicated that warning labels and education campaigns are insufficient to address the hazard because children do not comprehend warning labels; incidents occur when children are unattended (e.g., while left alone to nap); and renters may not be allowed to anchor products.

*Response:* Warnings, on their own, are unlikely to adequately address the hazard because they are unlikely to prevent a child from opening multiple drawers or climbing on a CSU, and consumers are unlikely to heed warnings, including warnings to anchor CSUs. Nevertheless, warning labels may have some benefit. Accordingly, the proposed rule requires a warning label on CSUs to inform consumers about the tip-over hazard; encourage the use of tip restraints as a secondary safety mechanism; and provide other safety information. The proposed warning label requirement addresses the child climbing hazard, tip restraint use, interlocks (if the product includes them), drawer loading (place the heaviest items in the lowest drawers), and CSU use with a television.

In addition, the proposed rule requires a hang tag label to provide consumers with meaningful information on the stability of a particular CSU, using a graphical representation of tip-over resistance, combined with an icon and text explanation, to allow consumers to make more informed purchasing decisions. This hang tag would provide a rating of the stability of the specific CSU that consumers could use to compare CSUs.

CPSC staff agrees that education campaigns could increase consumer knowledge of the CSU tip-over hazard and increase rates of anchoring. In June 2015, the Commission launched the Anchor It! campaign to educate consumers about the risk of injury or death from furniture, television, and appliance tip overs, and to promote the use of tip restraints to anchor furniture and televisions. However, educational campaigns, alone, have not adequately reduced the CSU tip-over hazard. As incident data demonstrates, there has not been a statistically significant decline in CSU tip-over incidents without televisions while these efforts have been in place. In addition, CPSC commissioned a study to assess consumer awareness, recognition, and behavior change as a result of the

Anchor It! Campaign. The 2020 report providing the results of this study indicates that the survey included 600 parents and caregivers of children 5 years old or younger and showed that only 55 percent of participants reported ever having anchored furniture.

### C. Scope and Definitions

*Comments:* Comments about the scope of a rule varied. Several commenters suggested including in the scope furniture less than 30 inches in height, and others supported limiting the scope to furniture more than 30 inches in height. One commenter recommended limiting the scope of a rule to chests, bureaus, and dressers, because the CPSC annual tip-over and instability reports indicate that most incidents involve those products. One commenter recommended covering “freestanding chests, bureaus & dressers intended for clothing storage in a bedroom, with height dimensions over 30 inches (762 mm), consisting of a solid top and side panels and containing at least one drawer,” and suggested definitions for chests, bureaus, and dressers.

*Response:* In August 2019, ASTM published F2057–19, which revised the scope from including CSUs above 30 inches in height, to including CSUs equal to or above 27 inches in height. This change was based on incidents involving units 30 inches in height and under, including a fatal incident with a 27.5-inch-high unit. However, CPSC is aware of products that are marketed as CSUs and are under 27 inches high, and is aware of a fatal incident involving a 24-inch-high CSU with a television. On balance, staff considers it reasonable to include in the scope CSUs that are 27-inches high or more, and seeks comments on this issue.

Although most CSU tip-over incidents involve chests, bureaus, and dressers, additional furniture items, with the same/similar design and function as chests, bureaus, and dressers present the same hazard because the tip-over hazard relates to the design and use of the products. Similar products include wardrobes and armoires, as well as other products that consumers commonly recognize as CSUs, regardless of marketing. The FMG study (Tab Q of the NPR briefing package) indicates that consumers consider a variety of products suitable for use as CSUs. The ASTM F2057 definition of CSUs may exclude items that consumers use as CSUs. For this reason, the scope of the proposed rule uses criteria to distinguish between in-scope and out-of-scope products.

### D. Test Parameters

*Comments:* Several commenters recommended using a test weight of at least 60 pounds to address children younger than 6 years old. Commenters noted that covering children up to 6 years old would be consistent with the age and weight of victims in incidents and account for developmentally expected behaviors for children that age that are associated with incidents (e.g., climbing). Several comments also noted that victims as old as 8 years have been killed by falling furniture. One commenter urged CPSC to consider the 90th percentile child at their 6th and 8th birthdays “to better understand the risks posed to children older than 5.” One commenter supported the ASTM test weight of 50 pounds, stating: “the most at-risk age group are children 1 to 4 years old” and the 50-pound test weight “appropriately reflects the age and weight of the most at-risk children based on the reported IDI data.”

*Response:* Staff agrees that the 50-pound test weight in ASTM F2057 is inadequate; however, the data and staff’s assessment have evolved since the ANPR. The ANPR discussed increasing the test weight to 60 pounds to represent the weight of “children up to and including age five,” which is the age group that ASTM F2057 aims to cover. After the ANPR, staff worked with the F15.42 Furniture Subcommittee to provide evidence to increase the test weight to 60 pounds, based on updated 95th percentile weight data. ASTM balloted the weight increase, but it did not pass. The primary data source for the 60-pound weight recommendation was the 2000 Centers for Disease Control and Prevention (CDC) Growth Charts.<sup>123</sup> In the updated 2021 CDC Anthropometric Reference, children’s weights tend to be higher than those in the 2000 CDC Growth Charts.

After the ANPR, the UMTRI child climbing study (Tab R of the NPR briefing package) quantified forces and moments children generate when interacting with a simulated CSU. Staff focused on the ascent forces because CSU tip-over incident data indicates that children climbing CSUs is the most common hazard scenario in these incidents, and ascent is an integral climbing interaction. For the ascent interaction and an average drawer extension,<sup>124</sup> staff determined that a 50-

<sup>123</sup> Sixty pounds is the approximate 95th percentile weight of a 72-month-old male or 72-month-old female (the 95th percentile weight of a child just before his or her 6th birthday).

<sup>124</sup> The average drawer extension was 9.75 inches, for the purpose of this estimate, this extension was

pound child climbing could exert forces equivalent to those from an 80-pound test weight on the face of a drawer opened 12 inches. These results show that the 50-pound test weight in F2057 or even a 60-pound test weight would be inadequate to replicate the forces of a 50-pound child climbing.

For this NPR, staff also evaluated the ages and weights of children in CSU tip-over incidents. Most tip-over incidents involving children and CSUs without televisions involve 1, 2, and 3-year-old children. These are also the ages of children who are most involved in climbing incidents (the dominant hazard pattern). The 95th percentile weight of 3-year-old children is 51.2 pounds.<sup>125</sup> The children involved in fatal incidents with CSUs and no televisions weighed 45 pounds and under.<sup>126</sup>

Based on this information, the proposed rule simulates a 95th percentile 3-year-old (51.2 pounds) climbing on a CSU and generating associated dynamic and horizontal forces, rather than the 60-pound 5-year-old. When the relevant forces are considered, the 51.2-pound child weight is approximately equivalent to an 82-pound test weight on the face of a drawer opened 12 inches.<sup>127</sup> In addition, the proposed requirements simulate real-world conditions, such as multiple open and filled drawers, a carpeted surface, and a child pulling on the CSU. These factors are present in many tip-over incidents and contribute to the instability of a CSU. Staff determined that the proposed requirements would address all of the fatal incidents and the majority of the nonfatal incidents involving children and CSUs without televisions. The proposed requirements should also reduce incidents involving CSUs with televisions and incidents involving adults.

*Comments:* One commenter suggested a tiered test weight system, based on the height of the product, recommending that products less than 40 inches in

assumed to be the same as the distance of the extended drawer to the fulcrum.

<sup>125</sup> This weight is based on the 2021 CDC Anthropometric Reference for a 95th percentile 3-year-old male. The 95th percentile weight for a 3-year-old female is 42.5 pounds. A stability requirement based on the 51.2-pound male would also cover the 95th percentile 3-year-old female.

<sup>126</sup> Two fatal incidents involved 45-pound children, one involving a 2-year-old child, and one involving a 7-year-old child (the oldest CSU tip-over fatality without a television).

<sup>127</sup> The proposed requirements distinguish between child weight and test weight. The child weight is used in an equation, along with the distance from the fulcrum, that estimates the moment (rotational force) that a child will exert on a CSU while climbing.

height be tested with 50 pounds of weight, and products more than 40 inches in height be tested with 60 pounds of weight. The commenter reasoned that older children (who weigh more) are less likely to climb shorter products because they can reach the top without climbing.” One comment supported a tolerance of  $\pm 1$  pound for the test weight, consistent with the ASTM standard.

*Response:* Regarding a tiered test weight protocol, staff does not support using different tip forces for different height units because incident analysis indicates that there is not a strong relationship between unit height and child weight for fatal tip-over incidents.<sup>128</sup>

For test weight tolerance, CPSC staff considers a tolerance of  $\pm 1$  pound for each of the two test weight blocks required in ASTM F2057–19 to be too large. Based on the tolerance, the total weight of the test blocks can range from 48–52 pounds, an 8 percent variability between the lowest and highest allowed test weights. Staff has previously worked with the ASTM F15.42 Furniture Subcommittee to propose tighter tolerances for each test weight and for the total test weight. However, the proposed rule does not require a fixed test weight—rather, it consists of a tip-over moment measurement—making it unnecessary to specify a test weight tolerance.

*Comments:* Two commenters stated that more specificity is needed in the voluntary standard regarding the time frame to apply and maintain the test weight and contact of the test fixture with the drawer bottom.

*Response:* ASTM F2057–19 does not specify a time requirement to apply the 50-pound test weight or a specific amount of time that the CSU must support the weight without tipping over. Test methods in other ASTM standards (e.g., F963–17, *Standard Consumer Safety Specification for Toy Safety*, F2236–16a, *Standard Consumer Safety Specification for Soft Infant and Toddler Carriers*, and F2194–16<sup>e1</sup>, *Standard Consumer Safety Specification for Bassinets and Cradles*) state to apply a weight or force over a specific period to avoid imparting an impulse force on the product. To address this, the proposed rule specifies that the force must be applied gradually over a period of at least 5 seconds to avoid a potential impulse force.

<sup>128</sup> See CPSC staff letter to ASTM from Nesteruk, H.E.J., Re: Update to CPSC Staff letter dated August 24, 2018 (Oct. 12, 2018), available at: <https://cpsc.gov/s3fs-public/TipoverASTMLetter%20October18%20Update.pdf>.

*Comment:* Several commenters addressed open drawers during testing. Commenters emphasized that testing should reflect real-world conditions, and that opening one empty drawer at a time, as the ASTM standard requires, does not do this. Suggestions included multiple drawers being open simultaneously, loaded drawers, and testing drawers “at all stages of open.”

*Response:* CPSC agrees that stability testing should reflect real-world use, which includes opening more than one drawer at a time (unless the CSU prevents this, such as with an interlock system) and drawers filled with clothing. Staff tested a number of different types and sizes of CSUs with various configurations of open and filled drawers, and modeled CSUs involved in tip-over incidents. Staff concluded that having multiple open drawers decreases stability, and having filled drawers has a variable effect on stability, depending on whether the filled drawers are open or closed. Filled drawers make a CSU less stable if the drawers are open; whereas, filled drawers make the CSU more stable if the drawers are closed. Thus, the least stable configuration is when all drawers are filled and open. If less than half of the drawers are open, the least stable configuration (assuming that the drawer fill is consistent across drawers) is when all drawers are empty. The test method in the proposed rule includes all drawers open and filled to reflect the worst-case configuration. The test method also accounts for interlock systems that would prevent multiple drawers from being opened simultaneously and allows for a modified test configuration for these units. If the interlock allows fewer than half of the drawers to open, the proposed requirements involve the CSU being tested with all drawers empty, which reflects a worst-case configuration for these units. These recommendations reflect incident data, which include children opening all of the drawers in CSUs and incidents involving empty and filled CSU drawers.

*Comment:* Several commenters recommended that testing involve carpeting or a surface that mimics the effects of carpet, to reflect real-world use conditions and common incident conditions, and because this may decrease stability. Some commenters suggested using a standardized material, or some other way of ensuring carpet testing would be reliable and repeatable. One commenter submitted a report containing test data for dressers and chests tipping that found that CSUs were less stable on carpet than on hard

floors. Another commenter asked for a clear definition of “a hard, level, flat surface,” specified in ASTM F2057, and suggested evaluating floor materials, including carpet, but recommended using a standardized material.

*Response:* Incident data indicates that consumers commonly place CSUs on carpet, and testing indicates that carpet decreases CSU stability. CPSC staff tested CSUs on carpet to learn what effect a flooring surface can have on the stability of CSUs (Tab P of the NPR briefing package). Staff found that, in general, CSUs were less stable on carpet. Accordingly, the proposed rule includes an element to simulate the effect of carpet as part of the stability testing. Staff agrees with the concern that testing on actual carpet may present challenges and may not be repeatable. Staff testing (Tab D of the NPR briefing package) indicates that an incline of 1.5 degrees was the average angle that replicated tip weight on carpet. Accordingly, to provide a repeatable method, the proposed rule includes a 1.5-degree incline to simulate the effect of carpet during stability testing. For the testing on a “hard, flat, and level” surface, the proposed rule provides a definition of this phrase.

*Comments:* Several commenters mentioned operational sliding length with regard to how far to extend drawers during stability testing. One commenter provided specific suggestions for testing three different types of drawer slides: (1) Drawers without an outstop should be tested at  $\frac{2}{3}$  of the drawer extension; (2) drawers with an outstop should be tested with the drawer extended to the “valid outstop” (meaning an outstop that meets certain pull force and timing criteria); and (3) drawers with a self-closing feature should be tested with the drawer extended to the “static outstop” (meaning a position where the drawer remains in a static open position for a set time). Another commenter suggested clarifying the requirement in the voluntary standard that drawers are to be extended to  $\frac{2}{3}$  of the operational sliding length if there is no outstop because, with no minimum operational sliding length specified, the procedure for testing products with multiple outstops is unclear.

*Response:* Drawer extension is a key component of a tip event because the distance from the force application site to the fulcrum (pivot point) determines the moment (rotational forces) on a CSU. The proposed test method uses a moment calculation based on full drawer extension for drawers with an outstop, and requires  $\frac{2}{3}$  extension for drawers without an outstop. The

proposed rule requires that, for stability testing, drawers be open to the “maximum extension,” which is defined as:

Maximum extension means a condition when a drawer or pull-out shelf is open to the furthest manufacturer recommended use position, as indicated by way of a stop. In the case of slides with multiple intermediate stops, this is the stop that allows the drawer or pull-out shelf to extend the furthest. In the case of slides with a multi-part stop, such as a stop that extends the drawer or pull-out shelf to the furthest manufacturer recommended use position with an additional stop that retains the drawer or pull-out shelf in the case, this is the stop that extends the drawer or pull-out shelf to the manufacturer recommended use position. If the manufacturer does not provide a recommended use position by way of a stop, this is  $\frac{2}{3}$  the shortest internal length of the drawer measured from the inside face of the drawer front to the inside face of the drawer back or  $\frac{2}{3}$  the length of the pull-out shelf.

This definition addresses the issue of multiple outstops. The Commission requests comments on self-closing drawers.

#### E. Tip Restraints

*Comments:* Comments about anchoring systems generally supported the position that furniture should be stable on its own, without the need for tip restraints. Reasons included: Consumers may not have the option to anchor products (e.g., rentals that do not allow holes in walls, or brick/concrete walls); consumers may not have the skills to anchor furniture correctly; some consumers are not aware of the need to anchor furniture; and the burden should not be placed on consumers to make products safe. However, commenters noted that anchors could be useful for used or older furniture, but that consumers need to be informed about proper installation. In addition, commenters noted that ASTM F3096–14 is inadequate because requirements for anchors should “adequately assess the strength of all designs of anchoring devices and the components of such devices in real world use conditions” with clear pass/fail tests.

*Response:* Staff agrees that tip restraints should not be the primary method of preventing CSU tip overs and that CSUs should be inherently stable. Several research studies show that a large number of consumers do not anchor furniture, including CSUs. A 2010 CPSC Consumer Opinion Forum survey found that only 9 percent of participants had anchored the furniture under their televisions; for participants that had a CSU under their televisions, the anchoring rate was 10 percent of

participants.<sup>129</sup> A 2018 Consumer Reports nationally representative survey found that only 27 percent of consumers overall, and 40 percent of consumers with children under 6 years old at home, have an anchored piece of furniture in their homes.<sup>130</sup> A 2020 CPSC study on the Anchor It! campaign found that 55 percent of respondents reported ever having anchored furniture.<sup>131</sup> As the 2020 FMG study on furniture tip overs indicates (Tab Q of the NPR briefing package), reasons that consumers do not anchor furniture include: The belief that furniture does not need to be anchored if children are supervised; a perception that the furniture was stable enough; potential damage to walls; lack of knowledge about products; and difficulty installing tip restraints. For these reasons, the proposed rule does not include requirements for tip restraints, and focuses, instead, on inherent stability.

However, tip restraints may be useful as a secondary safety system, to improve the stability of existing CSUs or address additional child interactions. In future work, outside of this rulemaking effort, CPSC may evaluate appropriate requirements for tip restraints, and may work with ASTM to update its tip-restraint requirements. Based on a preliminary analysis, CPSC staff agrees that ASTM F3096–14 does not adequately address tip restraints in real-world use conditions. Staff believes that an appropriate test should assess the strength of the connection between the CSU and the wall, the attachment to the CSU and the wall, and test the tip restraint with common wall surfaces. In addition, as with ASTM F2057–19, ASTM F3096–14 uses a 50-pound static force to test the strength of the tip restraint, which may not represent the force on the tip restraint from a child and the CSU, especially for interactions that can generate dynamic forces, including those from older children.

<sup>129</sup> CPSC report on *Preliminary Evaluation of Anchoring Furniture and Televisions without Tools* (Technical Report CPSC/EXHR/TR—15/001), Butturini, R., Massale, J., Midgett, J., Snyder, S. (May 2015), available at: <https://www.cpsc.gov/s3fs-public/pdfs/Tipover-Prevention-Project-Anchors-without-Tools.pdf>.

<sup>130</sup> Peachman, R.R. Furniture Anchors Not an Easy Fix, as Child Tip-Over Deaths Persist (Nov. 5, 2018), available at: <https://www.consumerreports.org/furniture/furniture-anchors-not-an-easy-fix-as-child-tip-over-deaths-persist/>.

<sup>131</sup> CPSC *Anchor It! Campaign: Main Report*, FMG (Sep. 2, 2020), available at: [https://www.cpsc.gov/s3fs-public/CPSC-Anchor-It-Campaign-Effectiveness-Survey-Main-Report\\_Final\\_9\\_2\\_2020....pdf?gclid=Cj0O2FEXV9wm0tdJVAtacRLHIMK](https://www.cpsc.gov/s3fs-public/CPSC-Anchor-It-Campaign-Effectiveness-Survey-Main-Report_Final_9_2_2020....pdf?gclid=Cj0O2FEXV9wm0tdJVAtacRLHIMK).

#### F. Televisions

*Comments:* Several commenters addressed the involvement of CRT televisions in CSU tip-over incidents. Commenters stated that manufacturers stopped producing CRT televisions around 2008–2010. One commenter provided information regarding the transition from CRT televisions to flat screens, and suggested that this transition “has significantly reduced the potential hazard posed by TVs being placed on CSUs.” In addition, the commenter stated that “99 percent of TVs are taken out of service after 16 years, meaning the number of CRTs in consumers’ homes should be nearing zero by 2027.” Commenters also noted that the discontinued production of CRT televisions means that CPSC would be unable to regulate these products, making it difficult to address the hazard they present. One commenter stated that television involvement in tip-over incidents should not undermine CPSC’s efforts to focus on CSUs because the common denominator in incidents is a CSU.

*Response:* CPSC agrees that manufacturers’ widespread shift from CRT televisions to flat-panel televisions is likely to result in decreased use in homes and an associated decrease in tip-over incidents involving CSUs with CRT televisions. NEISS data indicates that, for 2010 through 2019, there is a statistically significant linear decline in child injuries involving all CSUs (including televisions); however, there is no linear trend detected in injuries to children involving CSU tip-over incidents without televisions. Therefore, the decline in estimated CSU tip-over injuries during that period was driven by a decrease in ED-treated tip-over injuries involving CSUs with televisions. It is important to note that the CPSC tip-over data include incidents with a variety of television types, including CRT televisions and flat-panel televisions. Because flat-panel televisions are generally much lighter than CRT televisions, staff believes they are less likely to cause severe injury. Staff also agrees that television involvement in CSU tip-over incidents should not undermine CPSC’s efforts to focus on CSUs.

The proposed rule focuses on tip-over hazards involving CSUs without televisions. However, increasing CSU stability should also decrease deaths and injuries from tip-over incidents involving CSUs with televisions.

#### G. Incidents/Risk

*Comments:* One comment compared the deaths due to CSU tip overs to the

number of children who drown, suggesting that deaths due to CSU tip overs were relatively low, by comparison. Another comment provided a lengthy discussion of incident data, suggesting that incidents were declining, televisions are the primary hazard, and that the majority of incidents affect children younger than 5 years old, rather than less than 6 years of age. This commenter stated: “for children 13 to 59-months, there has been a 34% reduction in reported IDIs for the 4-year period between 2011–2015.” Another commenter stated that CSU tip overs present a particular risk to children under 6 years old, due to physical and mental abilities and behaviors at these ages, noting that children under 6 years old are involved in 95 percent of deaths and 83 percent of injuries to children.

*Response:* The existence of other hazards, such as drowning deaths, does not diminish the need to address tip-over hazards. There were 193 reported CSU tip-over fatalities involving children and CSUs that occurred between January 1, 2000 and December 31, 2020. With the exception of 2010, there were at least three reported fatal tip-over incidents involving children and CSUs without televisions, each year from 2001 through 2017 (the last year for which death reporting is considered complete). Based on data from NEISS, CPSC staff estimates that there were 78,200 injuries from CSU tip overs (an estimated annual average of 5,600 injuries) treated in EDs from January 1, 2006 to December 31, 2019. Of these, an estimated 72 percent (an estimated 56,400 total and an estimated annual average of 4,000) were injuries to children. The estimated number of ED-treated injuries to children involving CSU tip overs was between about 2,500 and 5,900 injuries for each year from 2006 through 2019.

Incident data indicates that younger children are the most affected age group. In 91 percent of the tip-over fatalities involving children and CSUs without televisions (81 of 89), the victim was 1, 2, or 3 years old. An estimated 76 percent of ED-treated injuries to children involving CSU tip overs without televisions were to children 1 through 4 years old (an estimated 31,100 of 40,700), and an estimated 64 percent were to children 1 through 3 years old (an estimated 26,100 of 40,700). The oldest child in a tip-over fatality involving a CSU without a television was 7 years old; the oldest child with a reported ED-treated tip-over injury

involving a CSU without a television was 17 years old.<sup>132</sup>

With respect to the comment stating that CSU incidents are declining, CPSC staff found a statistically significant linear decline in ED-treated CSU tip-over injuries to children from 2010 to 2019. However, this trend is driven by the decline in CSU tip-over incidents that involve televisions; there was no detected decline in tip-over injuries to children involving CSUs without televisions during the same time frame.

With respect to the comment that there has been a 34 percent reduction in reported IDIs, CPSC notes that IDIs are not reported, but are based on staff assignments; that is, when CPSC receives a report of an incident, staff can request an IDI. Therefore, the raw number of IDIs is not a meaningful number for comparison; it only represents example scenarios for which staff has sought and compiled additional information through an investigation, and is not a representative number of annual incidents. Any increase or decrease in the number of IDIs is a function of various factors and not necessarily a reflection of the seriousness of the hazard or rate of incidents. Moreover, IDIs are based on many types of source documents, and it is not clear to which IDIs the commenter is referring.

#### H. Costs and Small Business Impacts

*Comments:* One commenter stated that increasing test weights would create costs because many CSUs do not comply with the existing test weight requirement in the ASTM standard. Another commenter stated that it is possible to alter designs to improve stability in an affordable way. The Small Business Administration (SBA) met with CPSC staff regarding the ANPR on February 7, 2018. The SBA expressed that its small business contacts are comfortable with the existing ASTM standard, but are concerned about a mandatory rule that differs from or is more stringent than the voluntary standard. Those concerns include the impacts a rule would have on existing inventories and when compliance with the mandatory standard would be required.

*Response:* CPSC believes that the proposed rule would require modifications or redesign of most CSUs on the market. To estimate the cost of modifying CSUs to comply with the proposed requirements, CPSC staff examined five CSU models (Tab H of the NPR briefing package). In some

<sup>132</sup> The oldest child in a tip-over fatality involving a CSU with a television was 8 years old.

cases, the cost to modify a particular CSU could be around \$5.80 per unit; but in other cases, the costs could exceed \$25 per unit. The cost of modifying lighter or taller CSUs could be greater than for heavier CSUs. Changes in the design of CSUs could impose other costs on consumers in the form of altered utility or convenience, including increased weight, reductions in the maximum drawer extensions, changes in the storage capacity of the CSU, or changes in the footprint of the CSU.

The initial regulatory flexibility analysis (IRFA) for this rule (Tab I of the NPR briefing package) specifically considers the impact of the proposed rule on small businesses. The analysis concludes that the proposed rule would likely have a significant impact on a substantial number of small entities.

### *I. Technical Feasibility*

*Comments:* Several commenters addressed the technical feasibility of designing CSUs that could reduce stability issues. Comments regarding feasibility primarily consisted of: (1) Comments that used test data showing a proportion of CSUs could pass certain tests as proof that it was feasible, and (2) comments that proposed specific solutions to address furniture tipping over. Suggestions included drawer slides that automatically close drawers or that require users to apply force continually to keep a drawer open; reducing the maximum extension length of drawers; wider CSU bases; bins in place of bottom drawers; and interlock systems that limit how many drawers can be open simultaneously. One commenter recommended that test requirements account for interlock systems.

*Response:* CPSC staff is aware of one CSU that meets the stability requirements in the proposed rule without modification. To address CSUs that do not already meet the proposed requirements, staff examined five CSUs to determine what modifications would allow them to meet the proposed requirements. Several modifications, including in combination, may improve the stability of CSUs, such as adding drawer interlocks, adding weight to the rear of the unit, decreasing the maximum drawer extensions, and shifting the front edge or feet (the fulcrum) of the CSU forward. Of the potential modifications for which staff was able to estimate the potential cost, the lowest costs were about \$5.80 per unit, but in other cases, the costs may exceed \$25. However, the extent of the modifications required would depend upon the characteristics of the CSU,

such as its weight, dimensions, and center of gravity.

Regarding the comments that provide specific design solutions, under section 7 of the CPSA, the Commission may issue performance requirements, or requirements for warnings and instructions; the Commission may not issue design requirements. Accordingly, the Commission cannot require the use of particular designs. However, these suggestions demonstrate that it is feasible to design more stable CSUs, and these or other design changes may be useful in modifying CSUs to comply with performance requirements.

### *J. Stories of Loss*

*Comments:* Three commenters shared their personal experiences with tragic incidents where a CSU tipped over and killed a child. These comments included valuable information about the activities and conditions involved in the tip-over incidents they described, including the loading of drawers, flooring, and how the child was interacting with the CSU. These comments also provided useful information about user knowledge of the risk, and the presence of warning labels and tip restraints.

These commenters expressed that safety needs to be built into the design of CSUs, rather than relying on consumer knowledge of the hazard, consumer installation of anchors, or warning labels. The commenters noted several factors that make it ineffective to rely on consumer knowledge and actions. For example, the commenters noted that children are exposed to the CSU hazard outside their homes, so anchors may not be installed; consumers buy used CSUs, which may not have anchors, instructions, or labels; and consumers may not be permitted to anchor products to a wall in a rental, or may lack the technical skills to anchor CSUs properly. The commenters stated that a mandatory standard should mimic real-life circumstances that have been involved in CSU incidents, including less stable flooring and loaded drawers.

*Response:* CPSC appreciates the courage of these parents in sharing their stories. To each of these parents, we thank you for sharing these stories and we are deeply sorry for your loss. CPSC staff has considered the information about the interactions and conditions involved in the tip-over incidents in developing this NPR. The performance criteria were based on the children's interactions seen in fatal and nonfatal incident reports, and they are based on measured child climbing forces and child strength data. The performance

criteria also are based on real-life CSU use, as seen in the incident reports, including opening multiple drawers, drawers filled with clothing, and placing the CSU on a carpeted floor. The incidents described in these comments are captured in the incident data set and have been incorporated into staff's analyses.

CPSC agrees that CSUs should be inherently stable and should not require a tip restraint to prevent tip overs. As explained above, there are several barriers to the use of tip restraints and research that suggests that the rate of anchoring CSUs is low. Additionally, although the proposed rule includes a warning label requirement to inform consumers of the hazard and to motivate them to install tip restraints as a secondary safety mechanism, warnings have limited effectiveness in addressing the tip-over hazard.

### **XI. Alternatives to the Proposed Rule**

The Commission considered several alternatives to reduce the risk of injuries and death related to CSU tip overs. However, as discussed below, the Commission concludes that none of these alternatives would adequately reduce the risk of injury.

#### *A. No Regulatory Action*

One alternative to the proposed rule is to take no regulatory action and, instead, rely on voluntary recalls, compliance with the voluntary standard, and education campaigns. The Commission has relied on these alternatives to address the CSU tip-over hazard to date.

Between January 1, 2000 and March 31, 2021, 40 consumer-level recalls occurred in response to CSU tip-over hazards. The recalled products were responsible for 328 tip-over incidents, involved 34 firms, and affected approximately 21,500,000 CSUs. ASTM F2057 has included stability requirements for unloaded and loaded CSUs since its inception in 2000 and, based on CPSC testing, there is a high rate of compliance with the standard; CPSC's market survey of 188 CSUs found that 91 percent complied with the stability requirements in ASTM F2057. In addition, CPSC's Anchor It! campaign—an education campaign intended to inform consumers about the risk of CSU tip overs, provide safety tips for avoiding tip overs, and promote the use of tip restraints—has been in effect since 2015.

Given that this alternative primarily relies on existing CPSC actions, the primary costs staff estimates for this alternative are associated with tip restraints. However, this alternative is

unlikely to provide additional benefits to adequately reduce the risk of CSU tip overs. For one, CPSC does not consider ASTM F2057 adequate to address the hazard because it does not account for several factors involved in tip-over incidents that contribute to instability, including multiple open and filled drawers, carpeting, and forces generated by children's interactions with the CSU. Based on the UMTRI studies of the dynamic forces imparted by children climbing on CSUs and staff testing of CSUs on carpeting, staff estimates that, even if all CSUs complied with ASTM F2057-19, that would only protect children weighing less than 29.1 pounds when climbing on a CSU, providing 70 percent of the benefits expected from the proposed rule.<sup>133</sup>

In addition, as Tab C of the NPR briefing package explains, several studies indicate that the rate of consumer anchoring of furniture, including CSUs, is low. A 2010 CPSC survey found that 9 percent of participants who responded to a question about anchoring furniture under their television indicated that they had; the same survey found that 10 percent of consumers who used a CSU to hold their television reported anchoring the CSU. A 2018 Consumer Reports study found that 27 percent of consumers overall, and 40 percent of consumers with children under 6 years old in the home, had anchored furniture; the same study found that 10 percent of those with a dresser, tall chest, or wardrobe had anchored it. CPSC's 2020 study on the Anchor It! campaign found that 55 percent of respondents (which included parents and caregivers of children 5 years old and younger) reported anchoring furniture. As such, on their own, these options have limited ability to further reduce the risk of injury and death associated with CSU tip overs. CPSC's use of this alternative to date illustrates this since, despite these efforts, there has been no declining trend in child injuries from CSU tip overs (without televisions).

#### *B. Require Performance and Technical Data*

Another alternative is to adopt a standard that requires only performance and technical data, similar to or the same as the hang tag requirements in the proposed rule, with no performance

requirements for stability. This could consist of a test method to assess the stability of a CSU model, a calculation for determining a stability rating based on the test results, and a requirement that the rating be provided for each CSU on a hang tag. A stability rating would give consumers information on the stability of CSU models they are considering, to inform their buying decisions, and potentially give manufacturers an incentive to achieve a higher stability rating to increase their competitiveness or increase their appeal to consumers that desire more stable CSUs. The hang tag could also connect the stability rating to safety concerns, providing consumers with information about improving stability.

Because this alternative would not establish a minimum safety standard, it would not require manufacturers to discontinue or modify CSUs. Therefore, the only direct cost of this alternative would be the cost to manufacturers of testing their CSUs to establish their stability rating and labeling their CSUs in accordance with the required information. Any changes in the design of the CSUs would be the result of manufacturers responding to changes in consumer demand for particular models.

However, the Commission does not consider this alternative adequate, on its own, to reduce the risk of injury from CSU tip overs. Similar to tip restraints, this alternative relies on consumers, rather than making CSUs inherently stable. This assumes that consumers will consider the stability rating, and accurately assess their need for more stable CSUs. However, this is not a reliable approach to address this hazard, based on the low rates of anchoring, and the FMG focus group, which suggests that caregivers may underestimate the potential for a CSU to tip over, and overestimate their ability to prevent tip overs by watching children. In addition, this alternative would not address the risk to children outside their homes (where the stability of CSUs may not have been considered), or CSUs purchased before a child's birth. The long service life of CSUs and the unpredictability of visitors or family changes in that timespan, and these potential future risks might not be considered at the time of the original purchase.

#### *C. Adopt a Performance Standard Addressing 60-Pound Children*

Another alternative is to adopt a mandatory standard with the same requirements as the proposed rule, but addressing 60-pound children, rather than 51.2-pound children. This

alternative would be more stringent than the proposed rule.

About 74 percent of CSU tip-over injuries to children involve children 4 years old and younger,<sup>134</sup> and these are addressed by the proposed rule, because the 95th percentile weight for 4-year-old children is approximately 52 pounds. The proposed rule would also address some of the injuries to children who are 5 and 6 years old, as well, because many of these children also weigh less than 51.2 pounds. Mandating a rule that would protect 60-pound children would increase the benefit associated with child fatal and nonfatal injuries by about \$10.9 million, and the rule could increase the benefits associated with reductions in adult fatal and nonfatal injuries by \$3.2 million or a total of \$14.1 million annually. This comes to about 3 cents per unit on an annual basis. Over an assumed 15-year life of a CSU, this comes to 7 cents per unit, assuming a 7 percent discount rate, 36 cents assuming a 3 percent discount rate, or 45 cents without discounting. Therefore, increasing the weight of the child protected to 60 pounds would only increase benefits by about 4.5 percent over the benefits that could be obtained by the proposed rule.

Presumably, the cost of manufacturing furniture that complies with this more rigorous alternative would be somewhat higher than the costs of manufacturing CSUs that comply with the proposed rule, using similar, but somewhat more extensive modifications. Because this alternative would provide only a limited increase in benefits, but a higher level of costs than the proposed rule, the Commission did not select this alternative.

#### *D. Mandate ASTM F2057 With a 60-Pound Test Weight*

Another alternative would be to mandate a standard like ASTM F2057-19, but replace the 50-pound test weight with a 60-pound test weight. Sixty pounds approximately represents the 95th percentile weight of 5-year-old children, which is the age ASTM F2057-19 claims to address. This alternative was discussed in the ANPR.

This alternative would be less costly than the proposed rule, because, based on CPSC testing, about 57 percent of CSUs on the market would already meet this requirement. The cost of modifying CSUs that do not comply is likely to be less than modifying them to comply with the proposed rule, which is more stringent.

<sup>134</sup> Based on NEISS estimates for 2015 through 2019.

<sup>133</sup> Staff estimates that the proposed rule would reduce nonfatal climbing injuries by 91 percent, addressing 375.48 of the 412 climbing NEISS cases reviewed. Staff estimates that a rule that protects children weighing 29.1 pounds or less would address only 110.08 of the incidents or about 27 percent.



By increasing the test weight, it is possible that this alternative would prevent some CSU tip overs. However, this alternative still would not account for the factors that occur during CSU tip-over incidents that contribute to instability, including multiple open and filled drawers, carpeting, and the horizontal and dynamic forces from children's interactions with the CSU. As this preamble and the NPR briefing package explain, a 60-pound test weight does not equate to protecting a 60-pound child. The UMTRI study demonstrates that children generate forces greater than their weight during certain interactions with a CSU, including interactions that are common in CSU tip-over incidents. Because this alternative does not account for these factors, staff estimates that it may only protect children who weigh around 38 pounds or less, which is approximately the 75th percentile weight of 3-year-old children. For these reasons, the Commission does not believe this alternative would adequately reduce the CSU tip-over hazard, and did not select this alternative.

#### *E. Longer Effective Date*

Another alternative would be to provide a longer effective date than the 30-day effective date in the proposed rule. It is likely that hundreds of manufacturers, including importers, will have to modify potentially several thousand CSU models to comply with the proposed rule, which will require understanding the requirements, redesigning the CSUs, and manufacturing compliant units. Delays in meeting the effective date could result in disruptions to the supply chain, or fewer choices being available to consumers, at least in the short term. A longer effective date could reduce the costs associated with the rule and mitigate potential disruption to the supply chain. However, delaying the effective date would delay the safety benefits of the rule as well. As such, the Commission did not select this alternative. However, the Commission requests comments about the proposed effective date.

## **XII. Paperwork Reduction Act**

This proposed rule contains information collection requirements that are subject to public comment and review by the Office of Management and Budget (OMB) under the Paperwork Reduction Act of 1995 (PRA; 44 U.S.C. 3501–3521). Under the PRA, an agency must publish the following information:

- A title for the collection of information;

- a summary of the collection of information;
- a brief description of the need for the information and the proposed use of the information;
- a description of the likely respondents and proposed frequency of response to the collection of information;
- an estimate of the burden that will result from the collection of information; and
- notice that comments may be submitted to OMB.

44 U.S.C. 3507(a)(1)(D). In accordance with this requirement, the Commission provides the following information:

*Title:* Safety Standard for Clothing Storage Units.

*Summary, Need, and Use of Information:* The proposed consumer product safety standard prescribes the safety requirements, including labeling and hang tag requirements, for CSUs. These requirements are intended to reduce or eliminate an unreasonable risk of death or injury to consumers from CSU tip overs.

Requirements for marking and labeling, in the form of warning labels, and requirements to provide performance and technical data by labeling, in the form of a hang tag, will provide information to consumers. Warning labels on CSUs will provide warnings to the consumer regarding product use. Hang tags will provide information to the consumer regarding the stability of the unit. These requirements fall within the definition of "collection of information," as defined in 44 U.S.C. 3502(3).

Section 27(e) of the CPSA authorizes the Commission to require, by rule, that manufacturers of consumer products provide to the Commission performance and technical data related to performance and safety as may be required to carry out the purposes of the CPSA, and to give notification of such performance and technical data at the time of original purchase to prospective purchasers and to the first purchaser of the product. 15 U.S.C. 2076(e). Section 2 of the CPSA provides that one purpose of the CPSA is to "assist consumers in evaluating the comparative safety of consumer products." 15 U.S.C. 2051(b)(2).

Section 14 of the CPSA requires manufacturers, importers, or private labelers of a consumer product subject to a consumer product safety rule to certify, based on a test of each product or a reasonable testing program, that the product complies with all rules, bans or standards applicable to the product. In the case that a CSU could be considered to be a children's product, the

certification must be based on testing by an accredited third-party conformity assessment body. The proposed rule for CSUs specifies the test procedure be used to determine whether a CSU complies with the requirements. For products that manufacturers certify, manufacturers would issue a general certificate of conformity (GCC).

Identification and labeling requirements will provide information to consumers and regulators needed to locate and recall noncomplying products. Identification and labeling requirements include content such as the name and address of the manufacturer.

Warning labels will provide information to consumers on hazards and risks associated with product use. Warning label requirements include size, content, format, location, and permanency.

The standard requires that CSU manufacturers provide technical information for consumers on a hang tag at the point of purchase. The information provided on the hang tag would allow consumers to make informed decisions on the comparative stability of CSUs when making a purchase and would provide a competitive incentive for manufacturers to improve the stability of CSUs. Specifically, the manufacturer of a CSU would provide a hang tag with every CSU that explains the stability of the unit. CSU hangtag requirements include:

- *Size:* Every hangtag shall be at least 5 inches wide by 7 inches tall.
- *Content:* Every CSU shall be offered for sale with a hang tag that states the stability rating for the CSU model.
- *Attachment:* Every hang tag shall be attached to the CSU and clearly visible. The hang tag shall be attached to the CSU and lost or damaged hang tags must be replaced. The hang tags may be removed only by the first purchaser.
- *Placement:* The hang tag shall appear on the product and immediate container of the product in which the product is normally offered for sale at retail. Ready-to-assemble furniture shall display the hang tag on the main panel of consumer-level packaging. Any units shipped directly to consumers shall contain the hang tag on the immediate container of the product.

• *Format:* The format of the hang tag is provided in the proposed rule and the hang tag shall include the elements shown in the example provided.

The requirements for the GCC are stated in section 14 of the CPSA. Among other requirements, each certificate must identify the manufacturer or private labeler issuing the certificate

and any third-party conformity assessment body, on whose testing the certificate depends, the date and place of manufacture, the date and place where the product was tested, each party's name, full mailing address, telephone number, and contact information for the individual responsible for maintaining records of test results. The certificates must be in English. The certificates must be furnished to each distributor or retailer of the product and to CPSC, if requested.

*Respondents and Frequency:*

Respondents include manufacturers and importers of CSUs. Manufacturers and importers will have to comply with the

information collection requirements when the CSUs are manufactured or imported; this is addressed further in the discussion of estimated burden.

*Estimated Burden:* CPSC has estimated the respondent burden in hours, and the estimated labor costs to the respondent. The hourly burden for labeling can be divided into two parts. The first part includes designing the label and the hang tag that will be used for each model. The second part includes physically attaching the label and hang tag to each CSU. Additionally, the burden for third-party testing is estimated for a subset of CSUs.

Manufacturers will have to place a hang tag on each CSU sold. In 2018,

about 43.6 million CSUs were sold in the United States. This would be a reasonable estimate of the number of responses per year. CPSC estimates there to be 7,000 suppliers of CSUs for which there would be an hourly burden, as defined by the PRA. CPSC estimates that there are about 35,000 different models of CSUs, or an average of 5 models per manufacturer.

*Estimate of Respondent Burden.* The hourly reporting burden imposed on firms includes the time it will take them to design and update hang tags, and identification labeling, including warning labels, as well as the hourly burden of attaching them to all CSUs sold domestically.

TABLE 7—ESTIMATED ANNUAL REPORTING BURDEN

Burden type	Type of supplier	Total annual responses	Length of response	Annual burden (hours)
Labeling, design and update .....	Manufacturer or Importer .....	35,000 .....	12 min .....	7,000
Labeling, attachment .....	Manufacturer, Importer, or Retailer .....	43.6 million ....	.06 min .....	43,600
Total Labeling Burden .....	.....	.....	.....	50,600
Third-party recordkeeping, certification .....	Manufacturers of Children's CSUs .....	21,800 .....	3 hours .....	65,400
Total Hourly Burden .....	.....	.....	.....	116,000

CPSC estimates that it could take an hour for a supplier to design the hang tags and identification labeling, and that the design could be used for a period of five years, or until the CSU is redesigned. At 60 minutes per hang tag, and an average of 5 models per firm, the hourly burden for designing a hang tag that will be used for five years is 1 hour (60 min × 5 models ÷ 5 years).

Therefore, for 7,000 firms, the annual burden would be 7,000 hours. CPSC estimates it could take 0.06 minutes (3.6 seconds) for a supplier to attach the hang tag to the CSU, for each of the 43.6 million units sold in the United States annually. Attaching the hang tag to the CSU would amount to an hourly burden of 43,600 hours (0.06 min × 43,600,000 CSUs).

In addition, three types of third-party testing of children's products are required: Certification testing, material change testing, and periodic testing. Requirements state that manufacturers conduct sufficient testing to ensure that they have a high degree of assurance that their children's products comply with all applicable children's product safety rules before such products are introduced into commerce. If a manufacturer conducts periodic testing, it is required to keep records that describe how the samples of periodic testing are selected. The hour burden of recordkeeping requirements will likely

vary greatly from product to product, depending on such factors as the complexity of the product and the amount of testing that must be documented. Therefore, estimates of the hour burden of the recordkeeping requirements are somewhat speculative.

CPSC estimates that 0.05 percent of all CSUs sold annually, 21,800 CSUs, are children's products and would be subject to third-party testing, for which 3 hours of recordkeeping and record maintenance will be required. Thus, the total hourly burden of the recordkeeping associated with certification is 65,400 hours (3 × 21,800).

*Labor Cost of Respondent Burden.* According to the U.S. Bureau of Labor Statistics (BLS), Employer Costs for Employee Compensation, the total compensation cost per hour worked for all private industry workers was \$36.64 (March 2021, Table 4, <https://www.bls.gov/news.release/pdf/ecec.pdf>). Based on this analysis, CPSC staff estimates that the labor cost of respondent burden would impose a cost to industry of approximately \$4,250,240 annually (116,000 hours × \$36.64 per hour).

*Respondent Costs Other Than Burden Hour Costs.* In addition to the labor burden costs addressed above, the hang tag requirement imposes additional annualized costs. These costs include capital costs for cardstock used for each

hang tag to be displayed and the wire or string used to attach the hang tag to the CSU. CPSC estimates the cost of the printed hang tag and wire for attaching the hang tag to the CSU will be about \$0.10. Therefore, the total cost of materials to industry would be about \$4.36 million per year (\$0.10 × 43.6 million units).

*Cost to the Federal Government.* The estimated annual cost of the information collection requirements to the federal government is approximately \$4,172, which includes 60 staff hours to examine and evaluate the information as needed for Compliance activities. This is based on a GS-12, step 5 level salaried employee. The average hourly wage rate for a mid-level salaried GS-12 employee in the Washington, DC metropolitan area (effective as of January 2021) is \$47.35 (GS-12, step 5). This represents 68.1 percent of total compensation (U.S. Bureau of Labor Statistics, "Employer Costs for Employee Compensation," March 2021, Table 2, percentage of wages and salaries for all civilian management, professional, and related employees: <https://www.bls.gov/news.release/ecec.t02.htm>). Adding an additional 31.9 percent for benefits brings average annual compensation for a mid-level salaried GS-12 employee to \$69.53 per hour. Assuming that approximately 60

hours will be required annually, this results in an annual cost of \$4,172 (\$69.53 per hour × 60 hours = \$4,171.80).

*Comments.* CPSC has submitted the information collection requirements of this rule to OMB for review, in accordance with PRA requirements. 44 U.S.C. 3507(d). CPSC requests that interested parties submit comments regarding information collection to the Office of Information and Regulatory Affairs, OMB (see the **ADDRESSES** section at the beginning of this NPR).

Pursuant to 44 U.S.C. 3506(c)(2)(A), the Commission invites comments on:

- Whether the proposed collection of information is necessary for the proper performance of CPSC's functions, including whether the information will have practical utility;
- the accuracy of CPSC's estimate of the burden of the proposed collection of information, including the validity of the methodology and assumptions used;
- ways to enhance the quality, utility, and clarity of the information the Commission proposes to collect;
- ways to reduce the burden of the collection of information on respondents, including the use of automated collection techniques, when appropriate, and other forms of information technology;
- the estimated burden hours associated with labels and hang tags, including any alternative estimates; and
- the estimated respondent cost other than burden hour cost.

### XIII. Initial Regulatory Flexibility Analysis<sup>135</sup>

This section provides an analysis of the impact on small businesses of a proposed rule that would establish a mandatory safety standard for CSUs. Whenever an agency is required to publish a proposed rule, section 603 of the Regulatory Flexibility Act (5 U.S.C. 601–612) requires that the agency prepare an initial regulatory flexibility analysis (IRFA) that describes the impact that the rule would have on small businesses and other entities. An IRFA is not required if the head of an agency certifies that the proposed rule will not have a significant economic impact on a substantial number of small entities. 5 U.S.C. 605. The IRFA must contain:

(1) A description of why action by the agency is being considered;

<sup>135</sup> Further details about the initial regulatory flexibility analysis are available in Tab I of the NPR briefing package. Additional information about costs associated with the rule are available in Tab H of the NPR briefing package.

(2) a succinct statement of the objectives of, and legal basis for, the proposed rule;

(3) a description of and, where feasible, an estimate of the number of small entities to which the proposed rule will apply;

(4) a description of the projected reporting, recordkeeping and other compliance requirements of the proposed rule, including an estimate of the classes of small entities which will be subject to the requirement and the type of professional skills necessary for preparation of the report or record; and

(5) identification, to the extent practicable, of relevant Federal rules that may duplicate, overlap or conflict with the proposed rule.

An IRFA must also describe any significant alternatives that would accomplish the stated objectives of the applicable statutes and that would minimize any significant economic impact of the proposed rule on small entities. Alternatives could include: (1) Establishing different compliance or reporting requirements that consider the resources available to small businesses; (2) clarification, consolidation, or simplification of compliance and reporting requirements for small entities; (3) use of performance rather than design standards; and (4) an exemption from coverage of the rule, or any part of the rule thereof, for small entities.

#### A. Reason for Agency Action

The intent of this rulemaking is to reduce deaths and injuries resulting from CSUs tipping over on children. These tip-over incidents commonly result when young children attempt to climb on the CSU or open drawers; the weight and interaction of the child combined with the weight of any open and filled drawers causes the CSU to tip forward and fall on the child. Children can be killed or injured from the impact of the CSU falling on them or by being trapped beneath the CSU, restricting their ability to breathe. This preamble, and Tab A of the NPR briefing package, provide incident data for CSU tip overs. In addition, the Preliminary Regulatory Analysis, above, and in Tab H of the NPR briefing package, provide further information about medically treated CSU tip-over injuries from the ICM. That data demonstrates the need for agency action, and staff considered that data for the IRFA.

#### B. Objectives of and Legal Basis for the Rule

The objective of the proposed rule is to reduce deaths and injuries resulting from tip-over incidents involving CSUs.

The Commission published an ANPR in November 2017, which initiated this proceeding to evaluate regulatory options and potentially develop a mandatory standard to address the risks of CSU tip-over deaths and injuries. The proposed rule would be issued under the authority of the CPSA.

#### C. Small Entities to Which the Rule Will Apply

The proposed rule would apply to small entities that manufacture or import CSUs. Manufacturers of CSUs are principally classified in the North American Industrial Classification (NAICS) category 337122 (non-upholstered wood household furniture manufacturing), but may also be categorized in NAICS codes 337121 (upholstered household furniture manufacturing), 337124 (metal household furniture manufacturing), or 337125 (household furniture (except wood and metal) manufacturing). According to data from the U.S. Census Bureau, in 2017, there were a total of 3,404 firms classified in these four furniture categories. Of these firms, 2,024 were primarily categorized in the non-upholstered wood furniture category. More than 99 percent of the firms primarily categorized as manufacturers of non-upholstered wood furniture would be considered small businesses, as were 97 percent of firms in the other furniture categories, according to the U.S. Small Business Administration (SBA) size standards.<sup>136</sup> CPSC notes that these categories are broad and include manufacturers of other types of furniture, such as tables, chairs, bed frames, and sofas. It is also likely that not all of the firms in these categories manufacture CSUs. Production methods and efficiencies vary among manufacturers; some make use of mass-production techniques, and others manufacture their products one at a time, or on a custom-order basis.

The number of U.S. firms that are primarily classified as manufacturers of non-upholstered wood household furniture has declined over the last few decades because retailers have turned to international sources of CSUs and other wood furniture. Additionally, firms that formerly produced all of their CSUs domestically have shifted production to foreign plants. Well over half (64 percent) of the value of apparent consumption of non-upholstered wood

<sup>136</sup> U.S. Small Business Administration, *Table of Small Business Size Standards Matched to North American Industry Classification System Codes* (2019), available at: [https://www.sba.gov/sites/default/files/2019-08/SBA%20Table%20of%20Size%20Standards\\_Effective%20Aug%2019%2C%202019\\_Rev.pdf](https://www.sba.gov/sites/default/files/2019-08/SBA%20Table%20of%20Size%20Standards_Effective%20Aug%2019%2C%202019_Rev.pdf).

furniture (net imports plus domestic production for the U.S. market) in 2019 was comprised of imported furniture, and this likely was true for CSUs, as well. Firms that import furniture would likely be impacted by any rule that the Commission might promulgate regulating CSUs because they would have to ensure that any products that they import meet the requirements of the rule.

Under the NAICS classification system, importers are classified as either wholesalers or retailers. Furniture wholesalers are classified in NAICS category 423210 (Furniture Merchant Wholesalers). According to the Census Bureau data, in 2017, there were 5,117 firms involved in household furniture importation and distribution. A total of 4,920 of these (or 96 percent) are classified as small businesses because they employ fewer than 100 employees (which is the SBA size standard for NAICS category 423210). Furniture retailers are classified in NAICS category 442110 (Furniture Stores). According to the Census Bureau, there were 13,826 furniture retailers in 2017. The SBA considers furniture retailers to be small businesses if their gross revenue is less than \$22 million. Using these criteria, at least 97 percent of the furniture retailers are small (based on revenue data from the 2012 Economic Census of the United States). Wholesalers and retailers may obtain their products from domestic sources or import them from foreign manufacturers.

#### *D. Compliance, Reporting, and Recordkeeping Requirements in the Proposed Rule*

The proposed rule would establish a mandatory standard that all CSUs would have to meet to be sold in the United States. The requirements of the proposed standard are described, in detail, in this preamble, and the proposed regulatory text is at the end of this notice.

In addition to performance, labeling, and performance and technical information requirements, the proposed rule would also prohibit any person from manufacturing or importing noncomplying CSUs in any 1-month period between the date of promulgation of the final rule and the effective date, at a rate that is greater than 105 percent of the rate at which they manufactured or imported CSUs during the base period for the manufacturer. The base period is the calendar month with the median manufacturing or import volume within the last 13 months immediately preceding the month of promulgation of the final rule.

In addition, section 14 of the CPSA requires manufacturers, importers, or private labelers of a consumer product subject to a consumer product safety rule to certify, based on a test of each product or a reasonable testing program, that the product complies with all rules, bans or standards applicable to the product. The proposed rule specifies the test procedure to use to determine whether a CSU complies with the requirements. For products that manufacturers certify, manufacturers would issue a general certificate of conformity (GCC). In the case of CSUs that could be considered children's products, the certification must be based on testing by an accredited third-party conformity assessment body.

The requirements for the GCC are stated in section 14 of the CPSA. Among other requirements, each certificate must identify the manufacturer or private labeler issuing the certificate and any third-party conformity assessment body, on whose testing the certificate depends, the date and place of manufacture, the date and place where the product was tested, each party's name, full mailing address, telephone number, and contact information for the individual responsible for maintaining records of test results. The certificates must be in English. The certificates must be furnished to each distributor or retailer of the product and to CPSC, if requested.

#### **1. Costs of the Proposed Rule That Would Be Incurred by Small Manufacturers**

CPSC staff evaluated potential modifications that could be made to CSUs to improve their stability and comply with the proposed rule. These potential modifications represent changes that could be made to existing CSU designs, rather than design changes, and were merely intended as an example of potential options manufacturers could use to comply with the proposed rule. The potential modifications are described in detail in Tab D of the NPR briefing package. The most effective modification staff identified for improving CSU stability was interlock systems, which limit the number of drawers that can be open simultaneously. Additional options include adding a counterweight to the CSU; extending the front legs or edge of the CSU; reducing the distance that drawers may be extended; and increasing the height of the front legs to tilt the CSU backwards. Most CSUs may require a combination of these modifications.

Based on an analysis of how five CSUs could be modified to meet the cost of the proposed rule, CPSC staff estimated the potential cost increases to CSU manufacturers. For four of the CSUs, the cost estimates were \$13 or more per unit, and in some cases exceeded \$25, which exceeds the estimated average benefits per unit. For the fifth CSU, the estimated cost estimates of the modifications were in the same range as the estimated benefits per unit. Firms may choose other methods or different combinations resulting in lower or higher costs. In addition to costs of product modifications, any reductions in utility that might be caused by modifications such as reductions in the drawer extensions or significantly higher weights have not been quantified; nor have any aesthetic costs or the possibility of a tripping hazard that might result from the addition of significant foot extensions. Some models could require such substantial modifications that they no longer have the characteristics of the original models and manufacturers might withdraw them from the market, creating some unquantified loss of consumer utility.

The above estimates include the variable costs related to changes such as additional hardware, materials that increase the weight, and increased shipping costs. They also include the fixed costs associated with the research and development required to redesign CSUs and tooling costs. If products have to be completely redesigned to meet the proposed standard (e.g., if adding weight or other minor modifications are not sufficient, and suppliers need to make drawers deeper and add new drawer slides), the changes could add substantial costs, or they could be offset with lighter weight front panels or tops. One supplier contacted by Industrial Economics Corporation, on behalf of CPSC, estimated the cost of redesigning a CSU model as \$18,000, including prototype, testing, engineering, and design.<sup>137</sup>

Costs of model redesign per unit produced would be greater for smaller manufacturers with lower production volumes. For smaller, lower-volume producers, the per-unit costs of the components necessary to modify their CSUs might also be higher than those for higher volume producers. CSUs that meet the requirements of the proposed

<sup>137</sup> Israel, J., Cahill, A., Baxter, J., Final Clothing Storage Units Cost Impact Analysis, Industrial Economics, Incorporated contract report (June 7, 2019), available at: [https://ecpsc.cpsc.gov/apps/6b-Temp/Section%206b%20Tracking/Final%20Clothing%20Storage%20Units%20\(CSUs\)%20Cost%20Impact%20Analysis.pdf](https://ecpsc.cpsc.gov/apps/6b-Temp/Section%206b%20Tracking/Final%20Clothing%20Storage%20Units%20(CSUs)%20Cost%20Impact%20Analysis.pdf).

rule may incorporate hardware designed to limit the ability of consumers to open multiple drawers at a time. Therefore, manufacturers would incur the costs of adding such drawer-interlock components. Based on information obtained from a CSU manufacturer, the cost of these components might average \$6 to \$12 per unit if the CSU only has one column of drawers. Component suppliers are likely to charge higher per unit prices to manufacturers that purchase fewer units. Also, larger companies with vertically integrated operations that own or operate suppliers can more easily adapt to changes in design and manufacturing, and therefore, may experience fewer impacts than smaller manufacturers without vertical integration.

Manufacturers would likely incur some additional costs to certify that their CSUs meet the requirements of the proposed rule as required by section 14 of the CPSA. The certification must be based on a test of each product or a reasonable testing program. The costs of the testing might be minimal, especially for small manufacturers that currently conduct testing for conformance to the current voluntary standard, ASTM F2057–19. Importers may also rely on testing completed by other parties, such as their foreign suppliers, if those tests provide sufficient information for the manufacturers or importers to certify that the CSUs comply with the proposed rule. In the case of CSUs that are children's products, which are thought to constitute a very small portion of the market for CSUs, the cost of the certification testing could be somewhat higher because it would be required to be conducted by an accredited third-party testing laboratory.

Small manufacturers and importers will also incur added costs of required warning labels and hang tags with comparative tip ratings. Those manufacturers currently using permanent warning labels in conformance with ASTM F2057–19, should not face significant incremental costs for the replacement labels specified by the proposed rule. The required hang tags showing tip ratings for each CSU would involve some incremental costs, although likely to be minor in relation to other product modifications required for compliance. The testing costs needed to generate the tip ratings will be incurred to comply with the performance testing of the proposed rule.

## 2. Impacts on Small Businesses

Average manufacturer shipment value for CSUs was \$118 per unit in 2018 (about \$104 for chests of drawers and

\$144 for dressers). The estimated costs to manufacturers for product modifications to comply with the proposed rule range from about \$5.80 (in one case) up to \$30 or more per unit. Generally, staff considers impacts that exceed one percent of a firm's revenue to be potentially significant. Because the estimated average cost per CSU could be between about 5 percent and 25 percent of the average revenue per unit for CSUs, staff believes that the proposed rule could have a significant impact on a substantial number of small manufacturers and importers that receive a significant portion of their revenue from the sale of CSUs.

For many small importers, the impact of the proposed rule would be expected to be similar to the impact on small domestic manufacturers. Foreign suppliers may pass much of the cost of redesigning and manufacturing CSUs that comply with the proposed rule to their domestic distributors. Therefore, the cost increases experienced by small importers would be similar to those experienced by small manufacturers.

Small importers would be responsible for issuing a GCC certifying that their CSUs comply with the rule. However, importers may rely upon testing performed and GCCs issued by their suppliers in complying with this requirement. In the case of CSUs that are children's products, the certification must be based on testing by an accredited third-party conformity assessment body, which may involve additional costs.

### *E. Federal Rules That May Duplicate, Overlap, or Conflict With the Proposed Rule*

CPSC did not identify any federal rules that duplicate or conflict with the proposed rule.

### *F. Alternatives Considered To Reduce the Burden on Small Entities*

As discussed in XI. Alternatives to the Proposed Rule, above, CPSC examined several alternatives to the proposed rule, which could reduce the burden on firms, including small entities. For the reasons described in that section, the Commission concluded that those alternatives would not adequately reduce the risk of injury and death associated with CSU tip overs, and is not proposing those alternatives.

As part of that analysis, staff considered alternatives that could reduce the impact on small entities, specifically. One such alternative that could be specific to small entities could be variations on the proposed standard, such as reducing the required tip moment or testing units with weight in

closed drawers of units with drawer interlock systems. Such modifications might reduce the need for other product changes, such as foot extensions, raising front feet, and added weight in the backs of CSUs. However, while perhaps reducing costs for manufacturers, such lessening of requirements would reduce the stability of units complying with the standard, thereby reducing the benefits of the standard.

Another alternative that could be specific to small entities would be a longer effective date for the rule. In its report on potential cost impacts, Industrial Economics, Incorporated<sup>138</sup> concluded from its limited subset of interviews that it appears likely that, unlike larger firms involved in ASTM standards development, "many small furniture makers are not aware of the potential regulations under consideration." Smaller firms may, therefore, find it much more difficult to meet an effective date of 30 days after the rule is published. As discussed in XI. Alternatives to the Proposed Rule, extending the period before the rule becomes effective could reduce costs, but would also delay the benefits of the rule.

See Tab I of the NPR briefing package for further discussion of alternatives to the proposed rule. The Commission seeks comments on any alternatives that would reduce the impact on small entities, while adequately reducing the risk of injury and death associated with CSU tip overs.

### *G. Request for Comments*

The Commission invites comments on this IRFA and the potential impact of the proposed rule on small entities, especially small businesses. In particular, the Commission seeks comments on:

- The types and magnitude of manufacturing costs that might disproportionately impact small businesses or were not considered in this analysis;
- the costs of the testing and certification, warning label, and hang tag requirements in the proposed rule;
- the different impacts on small businesses associated with different effective dates;
- different impacts of the proposed rule on small manufacturers or suppliers that compete in different segments of the CSU market; and
- other alternatives that would minimize the impact on small

<sup>138</sup> Industrial Economics, Incorporated (2019). Final Clothing Storage Units (CSUs) Market Research Report. CPSC Contractor Report. Researchers analyzed the characteristics of 890 CSUs, and found a height range of 18 to 138 inches.

businesses but would still reduce the risk of CSU tip-over incidents.

#### XIV. Incorporation by Reference

The proposed rule incorporates by reference ASTM F2057–19. The Office of the Federal Register (OFR) has regulations regarding incorporation by reference. 1 CFR part 51. Under these regulations, in the preamble of the NPR, an agency must summarize the incorporated material, and discuss the ways in which the material is reasonably available to interested parties or how the agency worked to make the materials reasonably available. 1 CFR 51.5(a). In accordance with the OFR requirements, this preamble summarizes the provisions of ASTM F2057–19 that the Commission proposes to incorporate by reference.

The standard is reasonably available to interested parties and interested parties can purchase a copy of ASTM F2057–19 from ASTM International, 100 Barr Harbor Drive, P.O. Box C700, West Conshohocken, PA 19428–2959 USA; telephone: 610–832–9585; [www.astm.org](http://www.astm.org). Additionally, during the NPR comment period, a read-only copy of ASTM F2057–19 is available for viewing on ASTM's website at: <https://www.astm.org/CPSC.htm>. Once a final rule takes effect, a read-only copy of the standard will be available for viewing on the ASTM website at: <https://www.astm.org/READINGLIBRARY/>. Interested parties can also schedule an appointment to inspect a copy of the standard at CPSC's Division of the Secretariat, U.S. Consumer Product Safety Commission, 4330 East-West Highway, Bethesda, MD 20814, telephone: 301–504–7479; email: [cpsc-os@cpsc.gov](mailto:cpsc-os@cpsc.gov).

#### XV. Testing, Certification, and Notice of Requirements

Section 14(a) of the CPSA includes requirements for certifying that children's products and non-children's products comply with applicable mandatory standards. 15 U.S.C. 2063(a). Section 14(a)(1) addresses required certifications for non-children's products, and sections 14(a)(2) and (a)(3) address certification requirements specific to children's products.

A "children's product" is a consumer product that is "designed or intended primarily for children 12 years of age or younger." *Id.* 2052(a)(2). The following factors are relevant when determining whether a product is a children's product:

- Manufacturer statements about the intended use of the product, including a label on the product if such statement is reasonable;

- whether the product is represented in its packaging, display, promotion, or advertising as appropriate for use by children 12 years of age or younger;

- whether the product is commonly recognized by consumers as being intended for use by a child 12 years of age or younger; and

- the Age Determination Guidelines issued by CPSC staff in September 2002, and any successor to such guidelines.

*Id.* "For use" by children 12 years and younger generally means that children will interact physically with the product based on reasonably foreseeable use. 16 CFR 1200.2(a)(2). Children's products may be decorated or embellished with a childish theme, be sized for children, or be marketed to appeal primarily to children. *Id.* 1200.2(d)(1).

As discussed above, some CSUs are children's products and some are not. Therefore, a final rule on CSUs would subject CSUs that are not children's products to the certification requirements under section 14(a)(1) of the CPSA and would subject CSUs that are children's products to the certification requirements under section 14(a)(2) and (a)(3) of the CPSA. The Commission's requirements for certificates of compliance are codified at 16 CFR part 1110.

*Non-Children's Products.* Section 14(a)(1) of the CPSA requires every manufacturer (which includes importers<sup>139</sup>) of a non-children's product that is subject to a consumer product safety rule under the CPSA or a similar rule, ban, standard, or regulation under any other law enforced by the Commission to certify that the product complies with all applicable CPSC-enforced requirements. 15 U.S.C. 2063(a)(1).

*Children's Products.* Section 14(a)(2) of the CPSA requires the manufacturer or private labeler of a children's product that is subject to a children's product safety rule to certify that, based on a third-party conformity assessment body's testing, the product complies with the applicable children's product safety rule. *Id.* 2063(a)(2). Section 14(a) also requires the Commission to publish a notice of requirements (NOR) for a third-party conformity assessment body (*i.e.*, testing laboratory) to obtain accreditation to assess conformity with a children's product safety rule. *Id.* 2063(a)(3)(A). Because some CSUs are children's products, the proposed rule is a children's product safety rule, as applied to those products. Accordingly,

if the Commission issues a final rule, it must also issue an NOR.

The Commission published a final rule, codified at 16 CFR part 1112, entitled *Requirements Pertaining to Third Party Conformity Assessment Bodies*, which established requirements and criteria concerning testing laboratories. 78 FR 15836 (Mar. 12, 2013). Part 1112 includes procedures for CPSC to accept a testing laboratory's accreditation and lists the children's product safety rules for which CPSC has published NORs. When CPSC issues a new NOR, it must amend part 1112 to include that NOR. Accordingly, as part of this NPR, the Commission proposes to amend part 1112 to add CSUs to the list of children's product safety rules for which CPSC has issued an NOR.

Testing laboratories that apply for CPSC acceptance to test CSUs that are children's products for compliance with the new rule would have to meet the requirements in part 1112. When a laboratory meets the requirements of a CPSC-accepted third party conformity assessment body, the laboratory can apply to CPSC to include 16 CFR part 1261, *Safety Standard for Clothing Storage Units*, in the laboratory's scope of accreditation of CPSC safety rules listed on the CPSC website at: [www.cpsc.gov/labsearch](http://www.cpsc.gov/labsearch).

#### XVI. Environmental Considerations

The Commission's regulations address whether CPSC is required to prepare an environmental assessment (EA) or an environmental impact statement (EIS). 16 CFR 1021.5. Those regulations list CPSC actions that "normally have little or no potential for affecting the human environment," and therefore, fall within a "categorical exclusion" under the National Environmental Policy Act (42 U.S.C. 4231–4370h) and the regulations implementing it (40 CFR parts 1500–1508) and do not require an EA or EIS. 16 CFR 1021.5(c). Among those actions are rules that provide performance standards for products. *Id.* 1021.5(c)(1). Because this proposed rule would create performance requirements for CSUs, the proposed rule falls within the categorical exclusion, and thus, no EA or EIS is required.

#### XVII. Preemption

Executive Order (E.O.) 12988, *Civil Justice Reform* (Feb. 5, 1996), directs agencies to specify the preemptive effect of a rule in the regulation. 61 FR 4729 (Feb. 7, 1996), section 3(b)(2)(A). In accordance with E.O. 12988, CPSC states the preemptive effect of the proposed rule, as follows:

The regulation for CSUs is proposed under authority of the CPSA. 15 U.S.C.

<sup>139</sup>The CPSA defines a "manufacturer" as "any person who manufactures or imports a consumer product." 15 U.S.C. 2052(a)(11).

2051–2089. Section 26 of the CPSA provides that “whenever a consumer product safety standard under this Act is in effect and applies to a risk of injury associated with a consumer product, no State or political subdivision of a State shall have any authority either to establish or to continue in effect any provision of a safety standard or regulation which prescribes any requirements as to the performance, composition, contents, design, finish, construction, packaging or labeling of such product which are designed to deal with the same risk of injury associated with such consumer product, unless such requirements are identical to the requirements of the Federal Standard.” 15 U.S.C. 2075(a). The federal government, or a state or local government, may establish or continue in effect a non-identical requirement for its own use that is designed to protect against the same risk of injury as the CPSC standard if the federal, state, or local requirement provides a higher degree of protection than the CPSA requirement. *Id.* 2075(b). In addition, states or political subdivisions of a state may apply for an exemption from preemption regarding a consumer product safety standard, and the Commission may issue a rule granting the exemption if it finds that the state or local standard: (1) Provides a significantly higher degree of protection from the risk of injury or illness than the CPSA standard, and (2) does not unduly burden interstate commerce. *Id.* 2075(c).

Thus, the CSU requirements proposed in today’s **Federal Register** would, if finalized, preempt non-identical state or local requirements for CSUs designed to protect against the same risk of injury and prescribing requirements regarding the performance, composition, contents, design, finish, construction, packaging or labeling of CSUs.

### XVIII. Effective Date

The CPSA requires that consumer product safety rules take effect at least 30 days after the date the rule is promulgated, but not later than 180 days after the date the rule is promulgated unless the Commission finds, for good cause shown, that an earlier or a later effective date is in the public interest and, in the case of a later effective date, publishes the reasons for that finding. 15 U.S.C. 2058(g)(1). The Commission proposes that this rule become effective 30 days after publication of the final rule in the **Federal Register**. The rule would apply to all CSUs manufactured or imported on or after that effective date. Consistent with that, the Commission also proposes that the amendment to part 1112 become

effective 30 days after publication of the final rule. The Commission requests comments on the proposed effective date.

### XIX. Proposed Findings

The CPSA requires the Commission to make certain findings when issuing a consumer product safety standard. Specifically, the CPSA requires the Commission to consider and make findings about the following:

- The degree and nature of the risk of injury the rule is designed to eliminate or reduce;
- the approximate number of consumer products subject to the rule;
- the need of the public for the products subject to the rule and the probable effect the rule will have on the cost, availability, and utility of such products;
- any means to achieve the objective of the rule while minimizing adverse effects on competition, manufacturing, and commercial practices;
- that the rule, including the effective date, is reasonably necessary to eliminate or reduce an unreasonable risk of injury associated with the product;
- that issuing the rule is in the public interest;
- if a voluntary standard addressing the risk of injury has been adopted and implemented, that either compliance with the voluntary standard is not likely to result in the elimination or adequate reduction of the risk or injury, or it is unlikely that there will be substantial compliance with the voluntary standard;
- that the benefits expected from the rule bear a reasonable relationship to its costs; and
- that the rule imposes the least burdensome requirement that prevents or adequately reduces the risk of injury.

15 U.S.C. 2058(f)(1), (f)(3). This section discusses these findings.

#### A. Degree and Nature of the Risk of Injury

Based on incident data available through NEISS and CPSRMS, there were 193 reported CSU tip-over fatalities to children (*i.e.*, under 18 years old), 11 reported fatalities to adults (*i.e.*, ages 18 through 64 years), and 22 reported fatalities to seniors (*i.e.*, ages 65 years and older) that were reported to have occurred between January 1, 2000 and December 31, 2020. Of the 193 reported child fatalities from CSU tip overs, 86 percent (166 fatalities) involved children 3 years old or younger, 6 percent (12 fatalities) involved 4-year-olds, 4 percent (7 fatalities) involved 5-year-olds, 2 percent (4 fatalities) involved 6-year-olds, less than one percent (1 fatality) involved a 7-year-old, and 2 percent (3 fatalities) involved 8-year-olds.

Based on NEISS, there were an estimated 78,200 injuries, an annual

average of 5,600 estimated injuries, related to CSU tip overs for all ages that were treated in U.S. hospital EDs from January 1, 2006 to December 31, 2019. Of the estimated 78,200 injuries, 56,400 (72 percent) were to children, which is an annual average of 4,000 estimated injuries to children over the 14-year period. In addition, the ICM projects that there were approximately 19,300 CSU tip-over injuries treated in other settings from 2015 through 2019, or an average of 3,900 per year. Combining the NEISS estimate of injuries treated in hospital EDs with the ICM estimate of medically attended injuries treated in other settings brings the estimate of all nonfatal, medically attended CSU tip-over injuries to children to 34,100 during the years 2015 through 2019.

Injuries to children, resulting from CSUs tipping over, include soft tissue injuries, skeletal injuries and bone fractures, and fatalities resulting from skull fractures, closed-head injuries, compressional and mechanical asphyxia, and internal organ crushing leading to hemorrhage.

#### B. Number of Consumer Products Subject to the Proposed Rule

In 2017, there were approximately 463.5 million CSUs in use. In 2018, combined shipments of dressers and chests totaled 43.6 million units. Annual sales of CSUs total about 44 million units.

#### C. The Public Need for CSUs and the Effects of the Proposed Rule on Their Utility, Cost, and Availability

Consumers commonly use CSUs to store clothing in their homes. The proposed rule provides a performance standard that requires CSUs to meet a minimum stability threshold, but does not restrict the design of CSUs. As such, CSUs that meet the standard would continue to serve the purpose of storing clothing in consumers’ homes. There may be a negative effect on the utility of CSUs if CSUs that comply with the standard are less convenient to use, such as altered designs to limit drawer extensions, an increase in the footprint of the product, or a reduction in storage capacity. Another potential effect on utility could occur if, in order to comply with the standard, manufacturers modify CSUs to eliminate certain desired characteristics or styles, or discontinue models. However, this loss of utility would be mitigated to the extent that other CSUs with similar characteristics and features are available that comply with the standard.

Retail prices of CSUs vary substantially. The least expensive units retail for less than \$100, while some

more expensive units may retail for several thousand dollars. Of the potential modifications to comply with the standard for which CPSC staff was able to estimate the potential cost, the lowest costs were about \$5.80 per unit; however, several were significantly higher. CSU prices may increase to reflect the added cost of modifying or redesigning products to comply with the standard, or to account for increased distribution costs if CSUs are heavier or include additional parts. In addition, consumers may incur a cost in the form of additional time to assemble CSUs if additional safety features are included.

If the costs associated with redesigning or modifying a CSU model to comply with the standard results in the manufacturer discontinuing that model, there would be some loss in availability of CSUs.

#### *D. Other Means To Achieve the Objective of the Proposed Rule, While Minimizing Adverse Effects on Competition and Manufacturing*

The Commission considered alternatives to achieving the objective of the rule of reducing unreasonable risks of injury and death associated with CSU tip overs. For example, the Commission considered relying on voluntary recalls, compliance with the voluntary standard, and education campaigns, rather than issuing a standard. Because this is the approach CPSC has relied on, to date, this alternative would have minimal costs; however, it is unlikely to further reduce the risk of injury from CSU tip overs.

The Commission also considered issuing a standard that requires only performance and technical data, with no performance requirements for stability. This would impose lower costs on manufacturers, but is unlikely to adequately reduce the risk of injury from CSU tip overs because it relies on manufacturers choosing to offer more stable units; consumer assessment of their need for more stable units (which CPSC's research indicates consumers underestimate); and does not account for CSUs outside a child's home or purchased before a child was born.

The Commission also considered mandating a standard like ASTM F2057–19, but replacing the 50-pound test weight with a 60-pound test weight. This alternative would be less costly than the proposed rule, because many CSUs already meet such a requirement, and it would likely cost less to modify noncompliant units to meet this less stringent standard. However, this alternative is unlikely to adequately reduce the risk of CSU tip overs because it does not account for factors that are

present in CSU tip-over incidents that contribute to CSU instability, including multiple open and filled drawers, carpeting, and forces generated by a child interacting with the CSU.

Another alternative the Commission considered was providing a longer effective date. This may reduce the costs of the rule by spreading them over a longer period, but it would also delay the benefits of the rule, in the form of reduced deaths and injuries.

Another alternative the Commission considered is adopting a mandatory standard with the requirements in the proposed rule, but addressing 60-pound children, rather than 51.2-pound children. However, this alternative would be more stringent than the proposed rule and, therefore, would likely increase the costs associated with the rule, while only increasing the benefits of the rule by about 4.5 percent.

#### *E. Unreasonable Risk*

As described above, incident data from NEISS and CPSRMS indicates that there were 226 reported CSU tip-over fatalities that were reported to have occurred between January 1, 2000 and December 31, 2020, of which 85 percent (193 incidents) were children, 5 percent (11 incidents) were adults, and 10 percent (22 incidents) were seniors. Of the reported child fatalities from CSU tip overs, 86 percent (166 fatalities) involved children 3 years old or younger.

Based on NEISS, there were an estimated 78,200 injuries, an annual average of 5,600 estimated injuries, related to CSU tip overs that were treated in U.S. hospital EDs from January 1, 2006 to December 31, 2019. Of these, 72 percent (56,400) were to children, which is an annual average of 4,000 estimated injuries to children over the 14-year period. In addition, the ICM projects that there were approximately 19,300 CSU tip-over injuries treated in other settings from 2015 through 2019, or an average of 3,900 per year. Combining the NEISS estimate of injuries treated in hospital EDs with the ICM estimate of medically attended injuries treated in other settings brings the estimate of all nonfatal, medically attended CSU tip-over injuries to children to 34,100 during the years 2015 through 2019.

Injuries to children when CSUs tip over can be serious. They include fatal injuries resulting from skull fractures, closed-head injuries, compressional and mechanical asphyxia, and internal organ crushing leading to hemorrhage; they also include serious nonfatal injuries, including skeletal injuries and bone fractures.

The Commission estimates that the rule would result in aggregate benefits of about \$305.5 million annually. Of the potential modifications for which staff was able to estimate the potential cost, the lowest costs were about \$5.80 per unit. Several were significantly higher. Even assuming the low cost of about \$5.80 per unit, assuming annual sales of at least 43 million units, the annual cost of the proposed rule would be around \$250 million. In addition, there is an unquantifiable cost to consumers associated with lost utility and availability, and increased costs.

The Commission concludes preliminarily that CSU tip overs pose an unreasonable risk of injury and finds that the proposed rule is reasonably necessary to reduce that unreasonable risk of injury

#### *F. Public Interest*

This proposed rule is intended to address an unreasonable risk of injury and death posed by CSUs tipping over. The Commission believes that adherence to the requirements of the proposed rule will significantly reduce CSU tip-over deaths and injuries in the future; thus, the rule is in the public interest.

#### *G. Voluntary Standards*

The Commission is aware of four voluntary and international standards that are applicable to CSUs: ASTM F2057–19, *Standard Consumer Safety Specification for Clothing Storage Units*; AS/NZS 4935: 2009, the Australian/New Zealand Standard for *Domestic furniture—Freestanding chests of drawers, wardrobes and bookshelves/bookcases—determination of stability*; ISO 7171 (2019), the International Organization for Standardization *International Standard for Furniture—Storage Units—Determination of stability*; and EN14749 (2016), the European Standard, *European Standard for Domestic and kitchen storage units and worktops—Safety requirements and test methods*. The Commission does not consider the standards adequate because they do not account for the multiple factors that are commonly present simultaneously in CSU tip-over incidents and that testing indicates decrease the stability of the CSU. These factors include multiple open and filled drawers, carpeted flooring, and dynamic forces generated by children's interactions with the CSU, such as climbing or pulling on the top drawer.

#### *H. Relationship of Benefits to Costs*

The aggregate benefits of the rule are estimated to be about \$305.5 million annually; and the cost of the rule is



estimated to be about \$250 million annually (based on the lowest estimated cost of potential modifications to the units staff evaluated). On a per unit basis, the Commission estimates the expected benefits per unit to be \$6.01, assuming a 7 percent discount rate; \$7.88 assuming a 3 percent discount rate; and \$9.90 without discounting. The Commission's lowest estimated expected cost to manufacturers per unit is \$5.80 (based on the CSUs evaluated), plus an unquantifiable cost to consumers associated with lost utility and availability, and increased costs. Based on this analysis, the Commission preliminarily finds that the benefits expected from the rule bear a reasonable relationship to the anticipated costs of the rule.

#### *I. Least Burdensome Requirement That Would Adequately Reduce the Risk of Injury*

The Commission considered less-burdensome alternatives to the proposed rule, but preliminarily concludes that none of these alternatives would adequately reduce the risk of injury.

The Commission considered relying on voluntary recalls, compliance with the voluntary standard, and education campaigns, rather than issuing a mandatory standard. This alternative would have minimal costs, but would be unlikely to reduce the risk of injury from CSU tip overs. The Commission has relied on these efforts to date, but despite these efforts, there has been no declining trend in child injuries from CSU tip overs (without televisions) from 2006 to 2019.

The Commission considered issuing a standard that requires only performance and technical data, with no performance requirements for stability. This would impose lower costs on manufacturers, but is unlikely to adequately reduce the risk of injury because it relies on manufacturers choosing to offer more stable units; consumer assessment of their need for more stable units (which CPSC's research indicates consumers underestimate); and does not account for CSUs outside a child's home or purchased before a child was born.

The Commission considered mandating a standard like ASTM F2057-19, but replacing the 50-pound test weight with a 60-pound test weight. This alternative would be less costly than the proposed rule, because many CSUs already meet such a requirement, and it would likely cost less to modify noncompliant units to meet this less stringent standard. However, this alternative is unlikely to adequately reduce the risk of CSU tip overs because

it does not account for several factors that are simultaneously present in CSU tip-over incidents and contribute to instability, including multiple open and filled drawers, carpeting, and forces generated by a child interacting with the CSU.

The Commission considered providing a longer effective date. This may reduce the costs of the rule by spreading them over a longer period, but it would also delay the benefits of the rule, in the form of reduced deaths and injuries.

#### **XX. Request for Comments**

The Commission invites comments on all aspects of the proposed rule. Comments should be submitted in accordance with the instructions in the **ADDRESSES** section at the beginning of this notice. The following are specific comment topics that the Commission would find helpful:

##### *A. Scope and Definitions*

- The scope of the proposed standard, including the products covered, and the characteristics used to define and identify CSUs;
- the listed exclusions, including whether the excluded products should be included, or whether other products should be excluded;
- whether the scope of the proposed rule should include CSUs under 27 inches, or all CSUs, regardless of height;
- whether lightweight units, including lightweight plastic units, should be excluded from the scope of the rule, and if so, the safety justification for doing so, and what the weight threshold should be and why;
- whether all freestanding items marketed and/or advertised as suitable for clothing storage should be included in the scope of the standard, even if they would otherwise be excluded based on their design;
- whether nightstands with drawers and/or doors should be included in the scope and what design features and safety considerations distinguish nightstands from CSUs;
- design features that distinguish non-CSU cabinets from door chests and other similar CSUs; and
- the proposed definitions, including whether any definitions should be modified, or any additional terms should be defined.

##### *B. Fill Requirements*

- Whether the fill amounts for drawers and pull-out shelves at 8.5 pounds per cubic foot are reasonable or should be revised;
- data on the weight of clothes in drawers; and

- whether pull-out shelves should be tested with the same storage density as drawers, or would a lower fill weight for pull-out drawers be appropriate (e.g., 4.25 pounds per cubic foot).

##### *C. Performance Requirements*

- The stability requirements, and whether they are adequate, or should be modified;
- whether the moment requirements should be increased (e.g., the same stability requirements as in the proposed rule, but with a 60-pound child interaction, or simulating more aggressive behavior) or decreased (e.g., use different force/moment values to simulate climbing);
- the proposed test methods and any alternatives;
- whether a 1.5-degree forward tilt adequately replicates the effects of a CSU resting on carpet;
- whether an inclined surface test should be added to account for sloped floors;
- whether ANSI/BIFMA SOHO S6.5-2008 (R2013) requirements for interlocks are appropriate to consider for CSU interlocks, or what different requirements to consider and why;
- whether the 30-pound proposed performance requirement is adequate to assess that the drawer interlock design cannot be easily defeated or overridden by consumers;
- whether drawer interlocks should be subject to a performance requirement to ensure designs cannot be easily defeated or overridden by consumers;
- whether labeling or instructions for proper leveling on carpet should be a requirement;
- whether levelling devices should be non-adjustable to account for carpeting;
- whether levelling devices should be allowed to be adjusted per the manufacturer instructions during stability testing;
- whether levelling devices should include preset heights to account for carpeting;
- whether levelling devices should require a permanent adjustment mark that indicates the position recommended for use on a carpeted surface;
- whether the criteria to measure the maximum tip-over load should be the rear of the CSU lifting off at least ¼ inch from the test surface;
- whether interlocks for ready-to-assemble furniture should be pre-assembled and/or automatically engage;
- how to test interlock systems that have an override, such as two drawers opened simultaneously, and how to determine whether children can engage an override, and associated test methods;

- whether interlocks on other extendible elements besides drawers should be considered (*e.g.*, doors, shelves);
- whether and how to test automatically closing drawers;
- whether all three of the comparison tip-over moments should be included in the standard, whether any should not be included, or whether any additional forces or interactions should be included;
- pull force and force application location; and
- drawer extension requirements during testing.

#### D. Child Interactions and Associated Forces

- Whether the test method should account for pull forces on the CSU, and the assumptions of pull force and force application location (*e.g.*, is the 17.2-pound horizontal force applied at maximum 4.12 feet vertical distance appropriate to simulate a child pulling a drawer or pulling on a CSU);
- assumptions relating to children's interactions with doors and associated forces, including whether interactions involving opening doors and climbing on doors should be addressed; and
- the adequacy of the proposed requirement regarding opening and climbing on doors.

#### E. Marking and Labeling

- Whether the proposed warning requirements are adequate, or should be modified;
- suggestions for the language and format of the warning label;
- suggestions for the language and format of the informational label;
- whether the graphical symbols being studied, as well as the symbols included in ASTM F2057–19 are appropriate, effective, and understandable;
- the size, content, symbols, format, location, and permanency of marking and labeling;
- whether there should be a warning on CSUs to anchor the television, when the CSU is suitable for holding a television;
- whether labeling or instructions for proper levelling on carpet should be a requirement, especially for CSUs with levelers to tilt the unit backwards on carpet; and
- whether the product and packaging should contain a label that states: “meets CPSC stability requirements.”

#### F. Hang Tags

- All aspects of the proposed hang tag requirements;
- whether the hang tag rating and explanatory text is understandable;

- suggestions for the language or format of the hang tag;
- potential rating calculations, and suggestions for other ratings; and
- improvements in the graphic quality that maintain symbolic, iconic representation of a tip-over event.

#### G. Tip Restraints

- Tip restraints, including their adequacy and suggestions for improving the tip restraint requirements outlined in ASTM F3096–14 and ASTM F2057–19;
- whether there should be a requirement that all CSUs come with a tip restraint and/or whether there should be a requirement that CSUs intended for use with televisions should include a television restraint device and/or means to anchor a television (including a flat panel televisions) on the CSU, such as a universal attachment point;
- potential test methods related to tip restraints, including whether requirements should address designs where tip restraint installation is mandatory to unlock drawers; and
- whether the Commission should develop tip restraint requirements, such as restraints permanently attached to the CSU or an attachment point, such as a D-ring, that will not fail when pulled at a specified force.

#### H. Economic Analysis (Preliminary Regulatory Analysis and IRFA)

- The annual unit sales of CSUs;
- the accuracy and reasonableness of the benefits estimates;
- the accuracy or reasonableness of the cost estimates for manufacturers and importers (if available, sales or other shipment data would be helpful);
- costs of the testing and certification requirements;
- costs associated with the warning label and hang tag requirements;
- the cost and other impacts of adding weight to the rear of the CSU to meet the requirements of the proposed rule;
- the practicality and costs of using levelers or other means of raising the front of a CSU to meet the requirements of the proposed rule;
- the potential modifications discussed in this preamble and the NPR briefing package, and their estimated costs;
- other ways CSUs could be modified to comply with the requirements of the proposed rule, including the potential cost of the modifications and other impacts on the CSUs or their utility. CPSC is particularly interested in ways that the cost of the modifications could be offset by making other changes in the

design of the CSUs or the manufacturing processes used;

- the sensitivity analysis and any other valuations used in CPSC's analysis;
- the types and magnitude of manufacturing costs that might disproportionately impact small businesses or were not considered in the agency's analysis;
- the different impacts on small businesses associated with different effective dates;
- the differential impacts of the proposed rule on small manufacturers or suppliers that compete in different segments of the CSU market; and
- other alternatives that would minimize the impact on small businesses but would still reduce the risk of CSU tip-over incidents.

#### I. Stockpiling

- The need for an anti-stockpiling requirement;
- the proposed manufacture and import limits; and
- the proposed base period for the stockpiling provision.

#### J. Effective Date

- The reasonableness of the proposed 30-day effective date and recommendations for a different effective date, if justified; and
- comments recommending a longer effective date should describe the problems associated with meeting the proposed effective date and the justification for a longer one.

#### XXI. Promulgation of a Final Rule

Section 9(d)(1) of the CPSA requires the Commission to promulgate a final consumer product safety rule within 60 days of publishing a proposed rule. 15 U.S.C. 2058(d)(1). Otherwise, the Commission must withdraw the proposed rule, if it determines that the rule is not reasonably necessary to eliminate or reduce an unreasonable risk of injury associated with the product, or is not in the public interest. *Id.* However, the Commission can extend the 60-day period for good cause shown, if it publishes the reasons for doing so in the **Federal Register**. *Id.*

The Commission finds there is good cause to extend the 60-day period for this rulemaking. Under both the Administrative Procedure Act (APA; 5 U.S.C. 551–559) and the CPSA, the Commission must provide an opportunity for interested parties to submit written comments on a proposed rule. 5 U.S.C. 553; 15 U.S.C. 2058(d)(2). The Commission typically provides 75 days for interested parties to submit written comments. Because of the size,

complexity, and potential impacts of this proposed rule, the Commission considers it appropriate to provide a 75-day comment period. In addition, the CPSA requires the Commission to provide interested parties with an opportunity to make oral presentations of data, views, or arguments. 15 U.S.C. 2058. This requires time for the Commission to arrange a public meeting for this purpose, and provide notice to interested parties in advance of that meeting. After receiving written and oral comments, CPSC staff must have time to review and evaluate those comments.

These factors make it impossible for the Commission to issue a final rule within 60 days of this proposed rule. Accordingly, the Commission finds there is good cause to extend the 60-day period.

**XXII. Conclusion**

For the reasons stated in this preamble, the Commission proposes requirements for CSUs to address an unreasonable risk of injury associated with CSU tip overs.

**List of Subjects**

16 CFR Part 1112

Administrative practice and procedure, Audit, Consumer protection, Reporting and recordkeeping requirements, Third-party conformity assessment body.

16 CFR Part 1261

Consumer protection, Imports, Incorporation by reference, Information, Labeling, Safety.

For the reasons discussed in the preamble, the Commission proposes to amend chapter II, subchapter B, title 16 of the Code of Federal Regulations as follows:

**PART 1112—REQUIREMENTS PERTAINING TO THIRD PARTY CONFORMITY ASSESSMENT BODIES**

■ 1. The authority citation for part 1112 continues to read as follows:

Authority: Pub. L. 110–314, section 3, 122 Stat. 3016, 3017 (2008); 15 U.S.C. 2063.

■ 2. Amend § 1112.15 by adding paragraph (b)(54) to read as follows:

**§ 1112.15 When can a third party conformity assessment body apply for CPSC acceptance for a particular CPSC rule or test method?**

\* \* \* \* \*

(b) \* \* \*

(54) 16 CFR part 1261, Safety Standard for Clothing Storage Units.

\* \* \* \* \*

■ 3. Add part 1261 to read as follows:

**PART 1261—SAFETY STANDARD FOR CLOTHING STORAGE UNITS**

Sec.

- 1261.1 Scope, purpose, application, and exemptions.
- 1261.2 Definitions.
- 1261.3 Requirements for interlocks.
- 1261.4 Requirements for stability.
- 1261.5 Requirements for marking and labeling.
- 1261.6 Requirements to provide performance and technical data by labeling.
- 1261.7 Prohibited stockpiling.
- 1261.8 Findings.

Authority: 15 U.S.C. 2051(b), 2056, 2058, 2063(c), 2076(e)

**§ 1261.1 Scope, purpose, application, and exemptions.**

(a) *Scope and purpose.* This part, a consumer product safety standard, prescribes the safety requirements, including labeling and hang tag requirements, for *clothing storage units*, as defined in § 1261.2(a). These requirements are intended to reduce or eliminate an unreasonable risk of death or injury to consumers from clothing storage unit tip overs.

(b) *Application.* Except as provided in paragraph (c) of this section, all clothing storage units that are manufactured in the United States, or imported, on or after [EFFECTIVE DATE OF FINAL RULE], are subject to the requirements of this part 1261, if they are *consumer products*. Section 3(a)(1) of the Consumer Product Safety Act (15 U.S.C. 2052(a)(1)) defines the term *consumer product* as an “article, or component part thereof, produced or distributed.

(1) For sale to a consumer for use in or around a permanent or temporary household or residence, a school, in recreation, or otherwise, or

(2) For the personal use, consumption or enjoyment of a consumer in or around a permanent or temporary household or residence, a school, in recreation, or otherwise.” The term does not include products that are not customarily produced or distributed for sale to, or for the use or consumption by, or enjoyment of, a consumer.

(c) *Exemptions.* The following products are exempt from this part:

- (1) *Clothes lockers*, as defined in § 1261.2(b), and
- (2) *Portable storage closets*, as defined in § 1261.2(s).

**§ 1261.2 Definitions.**

In addition to the definitions given in section 3 of the Consumer Product Safety Act (15 U.S.C. 2052), the following definitions apply for purposes of this part:

(a) *Clothing storage unit* means a *freestanding* furniture item, with *drawer(s)* and/or *door(s)*, that may be reasonably expected to be used for storing clothing, that is greater than or equal to 27 inches in height, and with a total *functional volume* of the *closed storage* greater than 1.3 cubic feet and greater than the sum of the total *functional volume* of the *open storage* and the total volume of the *open space*.

Common names for clothing storage units include, but are not limited to: Chests, bureaus, dressers, armoires, wardrobes, chests of drawers, drawer chests, chifforobes, and door chests. Whether a product is a clothing storage unit depends on whether it meets this definition. Some products that generally do not meet the criteria in this definition and, therefore, likely are not considered clothing storage units are: Shelving units, office furniture, dining room furniture, laundry hampers, built-in closets, and single-compartment closed rigid boxes (storage chests).

(b) *Clothes locker* means a predominantly metal furniture item without exterior drawers and with one or more doors that either locks or accommodates an external lock.

(c) *Closed storage* means storage space inside a *drawer* and/or behind an opaque *door*. For this part, both sliding and hinged doors are considered in the definition of *closed storage*.

(d) *Door* means a hinged furniture component that can be opened or closed, typically outward or downward, to form a barrier; or a sliding furniture component that can be opened or closed by sliding across the face or case of the furniture item. This does not include vertically opening hinged lids.

(e) *Door extension from fulcrum distance* means the horizontal distance measured from the farthest point of a hinged door that opens outward or downward, while the door is in a position where the center of mass of the door is extended furthest from the front face of the unit (typically 90 degrees), to the *fulcrum*, while the CSU is on a *hard, level, and flat test surface*. See figure 1 to this paragraph (e). Sliding doors that remain within the CSU case are not considered to have a door extension.

**Figure 1 to paragraph (e)—(Top View) The *door extension from fulcrum distance*, illustrated by the letter **Y**.**

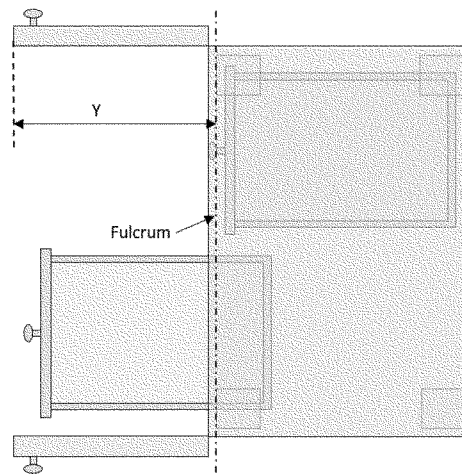

(f) *Drawer* means a furniture component intended to contain or store items that slides horizontally in and out of the furniture case and may be attached to the case by some means, such as glides.

(g) *Drawer or pull-out shelf extension from fulcrum distance* means the horizontal distance measured from the centerline of the front face of the *drawer* or the outermost surface of the pull-out shelf to the *fulcrum*, when the drawer or pull-out shelf is at the *maximum*

*extension* and the CSU is on a *hard, level, and flat test surface*. For a curved or angled surface this measurement is taken where the distance is at its greatest. See figure 2 to this paragraph (g).

**Figure 2 to paragraph (g)—The *drawer extension from fulcrum distance*, illustrated by the letter **X**.**

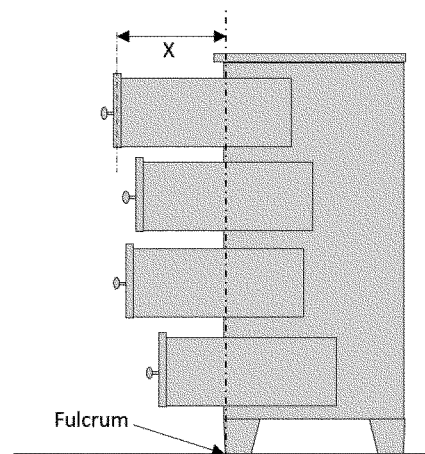

(h) *Freestanding* means that the unit remains upright, without requiring attachment to the wall, when it is fully assembled and empty, with all extension elements closed. Built-in units or units intended to be permanently attached to the building structure, other than by tip restraints, are not considered freestanding. Examples of units that are intended to

be permanently installed include, but are not limited to, kitchen cabinets and bathroom vanities.

(i) *Functional volume* of a *drawer* or *pull-out shelf* means the interior bottom surface area multiplied by the effective *drawer/pull-out shelf* height, which is distance from the bottom surface of the *drawer/pull-out shelf* to the top of the *drawer/pull-out shelf* compartment

minus  $\frac{1}{8}$  inches (see figure 3 to this paragraph (i)). *Functional volume* behind a *door* means the interior bottom surface area behind the *door*, when the *door* is closed, multiplied by the height of the storage compartment (see figure 4 to this paragraph (i)). *Functional volume* of *open storage* means the interior bottom surface area multiplied by the effective *open storage* height, which is

distance from the bottom surface of the *open storage* to the top of the *open storage compartment* minus  $\frac{1}{8}$  inches.

Figure 3 to paragraph (i)—*Functional volume of drawer or pull-out shelf.*

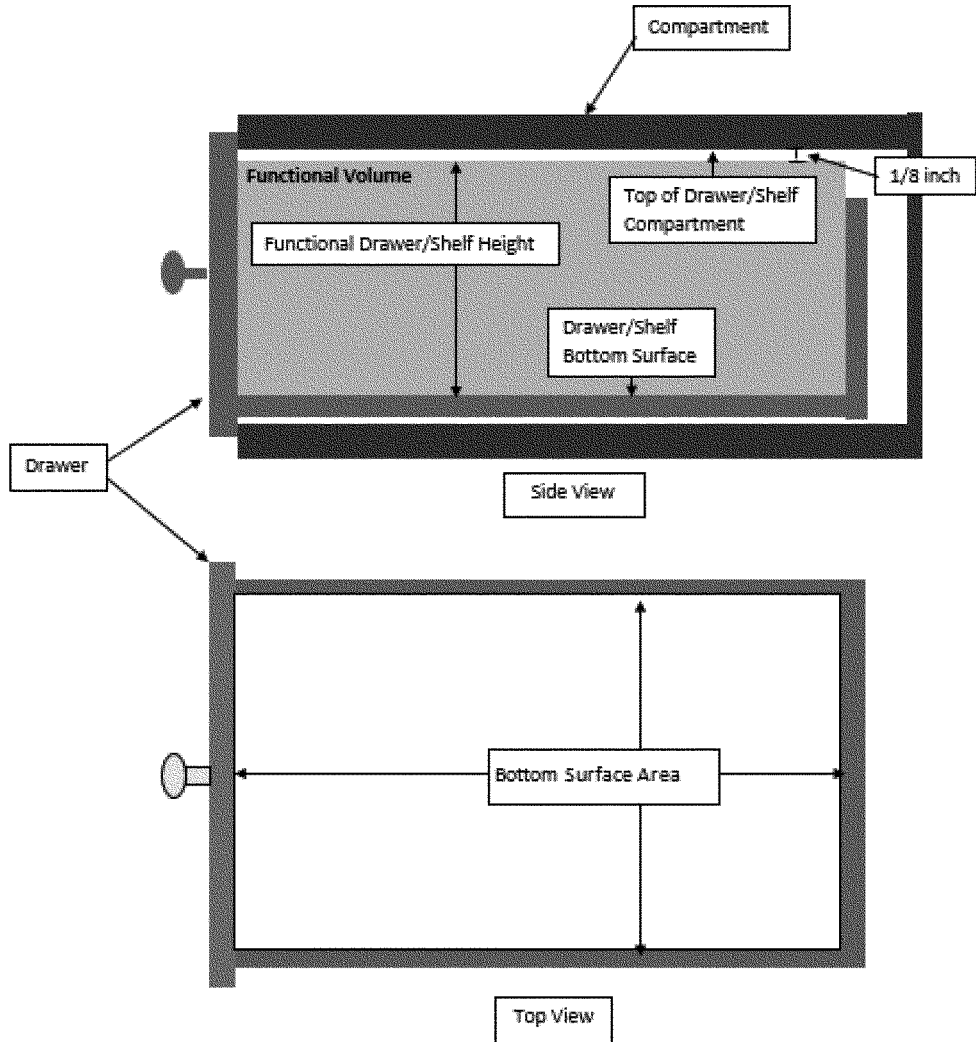
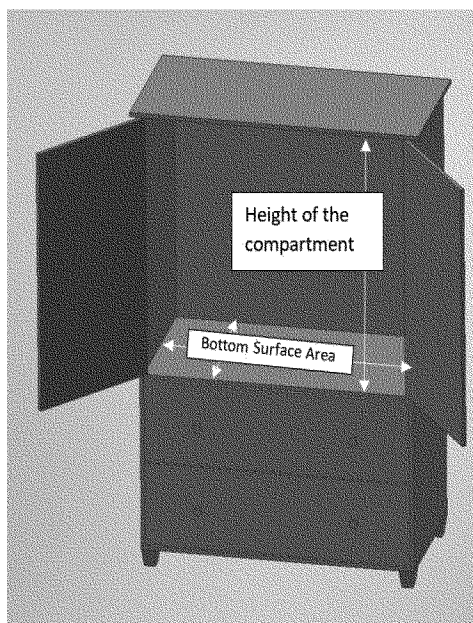

Figure 4 to paragraph (i)—*Functional volume behind a door.*

(j) *Fulcrum* means the point or line at the base of the CSU about which the CSU pivots when a *tip-over force* is applied (typically the front feet).

(k) *Hard, level, and flat test surface* means a test surface that is

(1) Sufficiently hard to not bend or break under the weight of a *clothing storage unit* and any loads associated with testing the unit;

(2) Level with no more than 0.5 degrees of variation; and

(3) Smooth and even.

(l) *Interlock* means a device that restricts simultaneous opening of *drawers*. An *interlock* may allow only one *drawer* to open at a time, or may

allow more than one *drawer*, but fewer than all the *drawers*, to open simultaneously.

(m) *Levelling device* means an adjustable device intended to adjust the level of the clothing storage unit.

(n) *Maximum extension* means a condition when a *drawer* or *pull-out shelf* is open to the furthest manufacturer recommended use position, as indicated by way of a stop. In the case of slides with multiple intermediate stops, this is the stop that allows the *drawer* or *pull-out shelf* to extend the furthest. In the case of slides with a multipart stop, such as a stop

that extends the *drawer* or *pull-out shelf* to the furthest manufacturer recommended use position with an additional stop that retains the *drawer* or *pull-out shelf* in the case, this is the stop that extends the *drawer* or *pull-out shelf* to the manufacturer recommended use position. If the manufacturer does not provide a recommended use position by way of a stop, this is  $\frac{2}{3}$  the shortest internal length of the *drawer* measured from the inside face of the *drawer* front to the inside face of the *drawer* back or  $\frac{2}{3}$  the length of the *pull-out shelf*. See figure 5 to this paragraph (n).

**Figure 5 to paragraph (n)—Example of *maximum extension* on *drawers and pull-out shelves* with stops and without stops.**

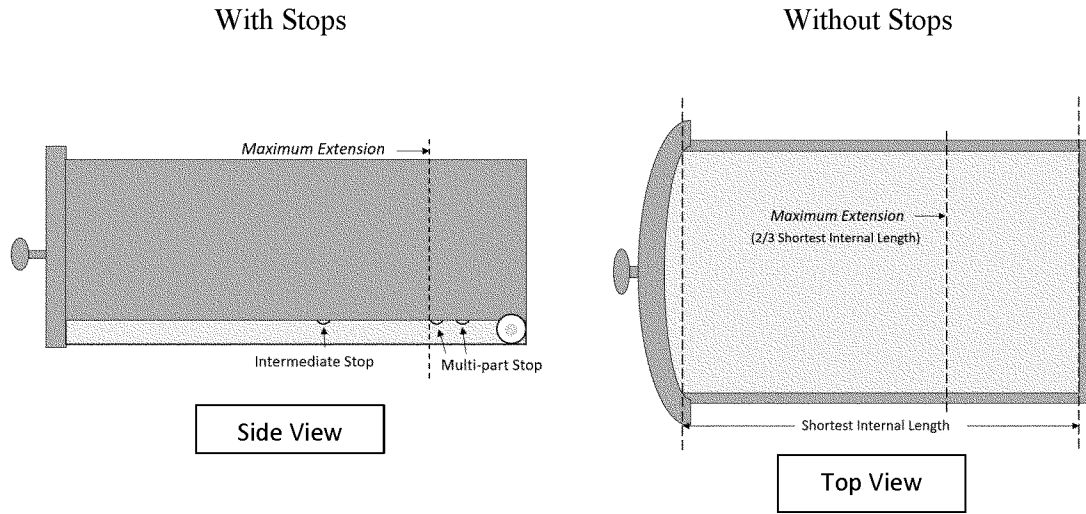

(o) *Maximum handhold height* means the highest position at which a child may grab hold of the CSU. This includes

the top of the CSU. This height is limited to a maximum of 4.12 feet from the ground, while the CSU is on a flat

and level surface. See figure 6 to this paragraph (o).

**Figure 6 to paragraph (o)—The *maximum handhold height*, illustrated by the letter *Z*.**

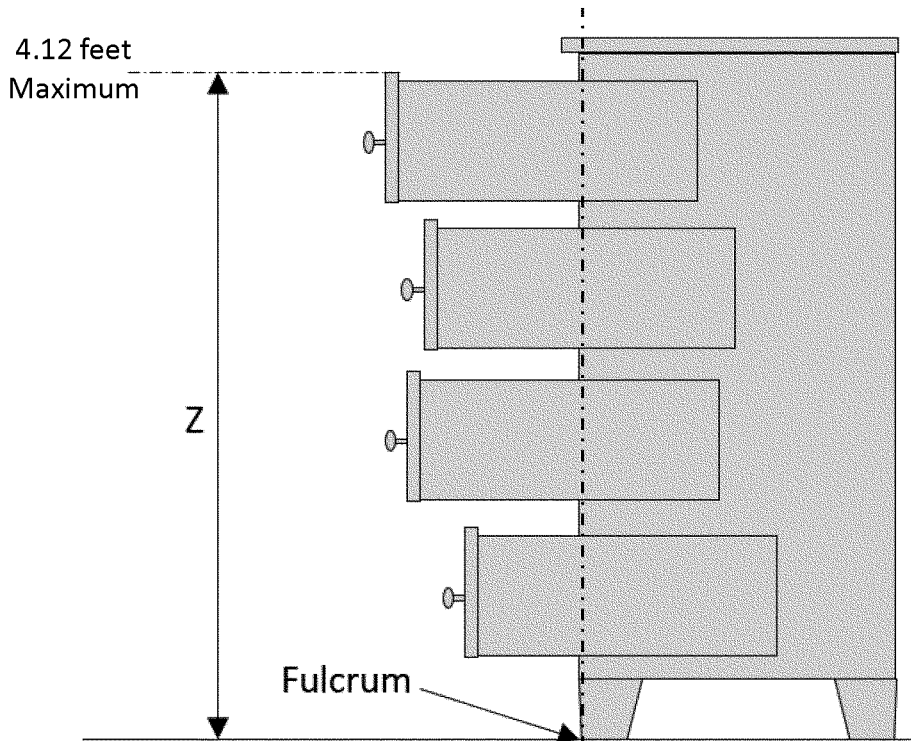

(p) *Moment* means a moment of a force, which is a measure of the tendency to cause a body to rotate about a specific point or axis. It is measured in pound-feet, representing a force

multiplied by a lever arm, or distance from the force to the point of rotation.

(q) *Open storage* means storage space enclosed on at least 5 sides by a frame

or panel(s) and/or behind a non-opaque door and with a flat bottom surface.

(r) *Open space* means space enclosed within the frame or panels, but without a bottom surface. For example, under

legs or between storage components, as with a vanity.

(s) *Portable storage closet* means a freestanding furniture item with an open frame that encloses hanging clothing storage space and/or shelves. This item may have a cloth case with curtain(s), flap(s), or door(s) that obscure the contents from view.

(t) *Pull-out shelf* means a furniture component with a horizontal flat surface that slides horizontally in and out of the furniture case and may be attached to the case by some means, such as glides.

(u) *Tip over* means the point at which a clothing storage unit pivots forward such that the rear feet or, if there are no feet, the edge of the CSU lifts at least  $\frac{1}{4}$  inch from the floor and/or is supported by a non-support element.

(v) *Tip-over force* means the force required to cause tip over of the clothing storage unit.

(w) *Tip-over moment* means the minimum moment in pounds-feet about the *fulcrum* that causes *tip over*.

#### § 1261.3 Requirements for interlocks.

(a) *General*. For all clothing storage units, including consumer-assembled units, the *interlock* components must be pre-installed, and automatically engage when the consumer installs the *drawers* in the unit. All *interlocks* must engage automatically as part of normal use.

(b) *Interlock pull test*. (1) If the unit is not fully assembled, assemble the unit according to the manufacturer's instructions.

(2) Place the unit on a *hard, level, and flat test surface*.

(3) If the unit has a *levelling device*, adjust the *levelling device* to the lowest level; then adjust the *levelling device* in accordance with the manufacturer's instructions.

(4) Secure the unit to prevent sliding or *tip over*.

(5) Open any *doors* in front of the *interlocked drawers*.

(6) Engage the *interlock* by opening a *drawer*, or the number of *drawers*

necessary to engage the interlock, to the *maximum extension*.

(7) Gradually apply over a period of at least 5 seconds a 30-pound horizontal pull force on each locked *drawer*, one *drawer* at a time, and hold the force for at least 10 seconds.

(8) Repeat this test until all possible combinations of *drawers* have been tested.

(c) *Performance requirement*. During the testing specified in paragraph (b) of this section, if any locked *drawer* opens or the *interlock* is damaged, then the *interlock* will be disabled or bypassed for the stability testing in § 1261.4(c).

#### § 1261.4 Requirements for stability.

(a) *General*. Clothing storage units shall be configured as described in paragraph (b) of this section, and tested in accordance with the procedure in paragraph (c) of this section. Clothing storage units shall meet the requirement for tip-over stability based on the minimum *tip-over moment* as specified in paragraph (d) of this section.

(b) *Test configuration*. The clothing storage unit used for tip-over testing shall be configured in the following manner:

(1) If the unit is not fully assembled, assemble the unit according to the manufacturer's instructions.

(2) Place the unit on a *hard, level, and flat test surface*.

(3) If the CSU has a *levelling device*, adjust the *levelling device* to the lowest level; then adjust the *levelling device* in accordance with the manufacturer's instructions.

(4) Tilt the CSU forward to 1.5 degrees by one of the following methods:

(i) Raise the rear of the unit until the unit has a 1.5-degree forward tilt, or

(ii) Place the unit on a hard and flat 1.5-degree inclined surface, with the high point at the rear of the unit surface, or

(iii) Other means to achieve a 1.5-degree forward tilt.

(5) If the CSU has a *levelling device* intended for a carpeted surface, adjust

the level in accordance with the manufacturer's instructions for a carpeted surface.

(6) Open all hinged *doors* that open outward or downward to the position where the center of mass of the *door* is extended furthest from the front face of the unit (typically 90 degrees).

(7) For units without an *interlock*:

(i) Open all *drawers* and *pull-out shelves* to the *maximum extension*.

(ii) Place a fill weight in the center of each *drawer* or *pull-out shelf* consisting of a uniformly distributed mass in pounds that is 8.5 (pounds/cubic foot) times the *functional volume* (cubic feet).

(8) For units with an *interlock*:

(i) If, during the testing specified in § 1261.3(b), any locked *drawer* opens or the *interlock* is damaged, then disable or bypass the *interlock* for the stability testing required in this section, and follow the requirements for units without an *interlock*.

(ii) If, during the testing specified in § 1261.3(b), no locked *drawer* opens and the *interlock* is not damaged, then:

(A) Open all *drawers* that are not locked by the *interlock* system to the *maximum extension*, in the configuration most likely to cause tip over (typically the configuration with the largest *drawers* in the highest position open).

(B) If 50 percent or more of the *drawers* and *pull-out shelves* by *functional volume* are open, place a fill weight in the center of each *drawer* or *pull-out shelf*, including those that remain closed (see figure 1 to this paragraph (b)(8)), consisting of a uniformly distributed mass in pounds that is 8.5 (pounds/cubic foot) times the *functional volume* (cubic feet). Secure the fill weights to prevent sliding.

(C) If less than 50 percent of the *drawers* and *pull-out shelves* by *functional volume* are open, do not place a fill weight in any *drawers* or on any *pull-out shelves* (see figure 2 to this paragraph (b)(8)).



**Figure 1 to paragraph (b)(8)—If 50 percent or more of the *drawers/pull-out shelves* open, clothing storage units tested with fill weights in all drawers.**

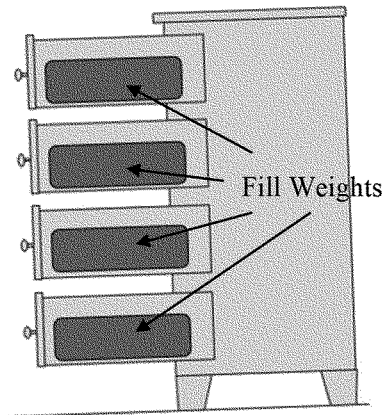

**Figure 2 to paragraph (b)(8)—If less than 50 percent of the *drawers/pull-out shelves* open, clothing storage units tested empty.**

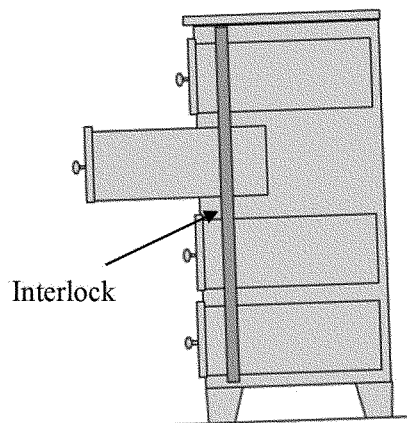

(c) *Test procedure to determine tip-over moment of the unit.* Perform one of the following two tip-over tests (Test Method 1 or Test Method 2), whichever is the most appropriate for the unit:

(1) Test Method 1 can be used for units with *drawers* or *pull-out shelves*. Gradually apply over a period of at least

5 seconds a vertical force to the face of the uppermost extended *drawer/pull-out shelf* of the unit to cause the unit to *tip over*. Record the *tip-over force* and horizontal distance from the force application point to the *fulcrum*. Calculate the *tip-over moment* of the unit by multiplying the *tip-over force*

(pounds) by the horizontal distance from the force application point to the *fulcrum* (feet). See figure 3 to this paragraph (c)(1). NOTE: If a drawer breaks during the test due to the force, use Test Method 2 or secure or reinforce the drawer, as long as the modifications do not increase the *tip-over moment*.

**Figure 3 to paragraph (c)(1)—Illustration of force application methods for Test**

**Method 1 with vertical load  $L_V$  (tilt angle not to scale).**

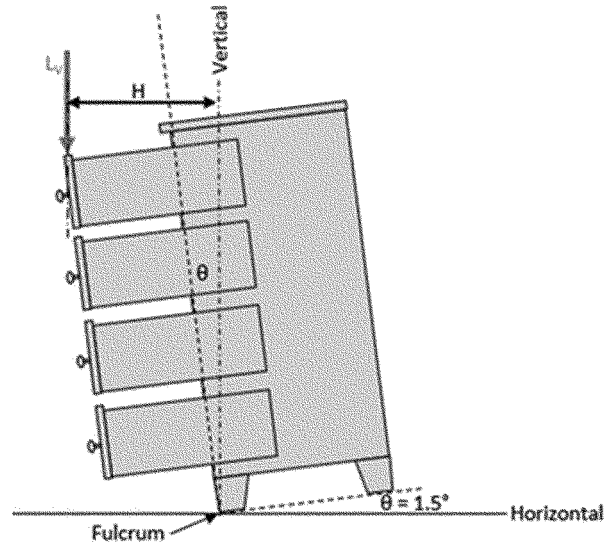

(2) Test Method 2 can be used for any unit. Gradually apply over a period of at least 5 seconds a horizontal force to the back of the unit orthogonal to the *fulcrum* to cause the unit to *tip over*.

Record the force and the vertical distance from the force application point to the *fulcrum*. Calculate the *tip-over moment* of the unit by multiplying the *tip-over force* (pounds) by the

vertical distance from the force application point to the *fulcrum* (feet). See figure 4 to this paragraph (c)(2).

**Figure 4 to paragraph (c)(2)—Illustration of force application methods for Test Method 2**

**with horizontal load  $L_H$  (tilt angle not to scale).**

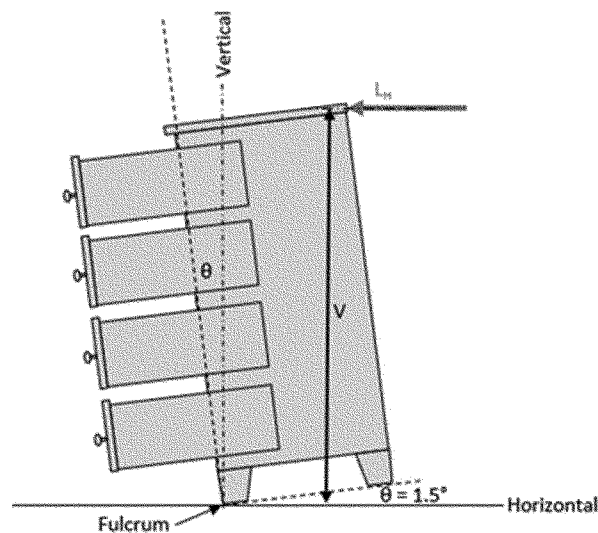

(d) *Performance requirement*. The *tip-over moment* of the clothing storage unit must be greater than the threshold

moment, which is the greatest of all of the applicable moments in paragraphs (d)(1) through (3) of this section:

(1) For units with a *drawer(s)* or *pull-out shelf(ves)*: 55.3 pounds times the *drawer or pull-out shelf extension from*

*fulcrum distance* in feet + 26.6 pounds feet;

(2) For units with a *door(s)*: 51.2 pounds times the *door extension from fulcrum distance* in feet—12.8; and

(3) For all units: 17.2 pounds times *maximum handhold height* in feet.

**§ 1261.5 Requirements for marking and labeling.**

(a) *Warning label requirements.* The clothing storage unit shall have a warning label, as defined below and as shown in figure 1 to this paragraph (a).

(1) *Size.* The warning label shall be at least 2 inches wide by 2 inches tall.

(2) *Content.* (i) The warning label shall contain the following text:

**Children have died from furniture tip over. To reduce the risk of tip over:**

- ALWAYS secure this furniture to the wall using an anti-tip device
- NEVER allow children to stand, climb, or hang on drawers, doors or shelves.
- [for units with interlocks only] Do not defeat or remove the drawer interlock system
- Place heaviest items in the lowest drawers
- [for units that are not designed to hold a television only] NEVER put a TV on this furniture

(ii) The warning label shall contain the child climbing symbol displayed in figure 1 to this paragraph (a), with the prohibition symbol in red. For units that are not designed to hold a television, the warning label shall contain the no television symbol displayed in figure 1, with the prohibition symbol in red.

(3) *Format.* The warning label shall use the signal word panel content and format specified in Section 8.2.2 of ASTM F2057–19, *Standard Safety Specification for Clothing Storage Units*, and the font, font size, and color specified in Section 8.2.3 of ASTM F2057–19 (incorporated by reference, see paragraph (c) of this section). Each safety symbol shall measure at least 1 in. by 1 in. See figure 1 to this paragraph (a).

(4) *Location.* (i) For units with one or more drawer(s):

(A) The warning label shall be located on the interior side panel of a drawer in the upper most drawer row, or if the top of the drawer(s) in the upper most drawer row is more than 56 inches from the floor, on the interior side panel of a drawer in the upper most drawer row

below 56 inches from the floor, as measured from the top of the drawer.

(B) The top left corner of the warning label shall be positioned within 1 inch of the top of the drawer side panel and within the front 1/3 of the interior drawer depth.

(ii) For units with only doors: The warning label shall be located on an interior side or back panel of the cabinet behind the door(s), or on the interior door panel. The warning label shall not be obscured by a shelf or other interior element.

(iii) For consumer-assembled units: The warning label shall be pre-attached to the panel, and the assembly instructions shall direct the consumer to place the panel with the warning label according to the placement requirements in paragraphs (a)(4)(i) and (ii) of this section.

(5) *Permanency.* The warning label shall be legible and attached after it is tested using the methods specified in Section 7.3 of ASTM F2057–19, *Standard Safety Specification for Clothing Storage Units* (incorporated by reference, see paragraph (c) of this section).

**Figure 1 to paragraph (a)—Example warning label for a clothing storage unit with an interlock system and not designed to hold a television (top) and for a clothing storage unit without an interlock system and designed to hold a television (bottom).**

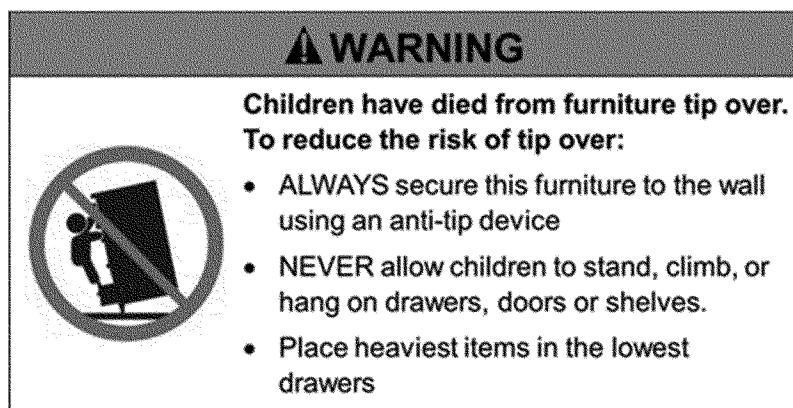

**BILLING CODE 6355-01-C**

(b) *Identification labeling requirements.* The clothing storage unit shall have an identification label, as defined in this paragraph (b)

(1) *Size.* The identification label shall be at least 2 inches wide by 1 inch tall.

(2) *Content.* The identification label shall contain the following:

(i) Name and address (city, state, and zip code) of the manufacturer, distributor, or retailer; the model number; and the month and year of manufacture.

(ii) The statement “Complies with U.S. CPSC Safety Standard for Clothing Storage Units,” as appropriate; this label may spell out “U.S. Consumer Product Safety Commission” instead of “U.S. CPSC.”

(3) *Format.* The identification label text shall not be less than 0.1 in. (2.5

mm) capital letter height. The text and background shall be contrasting colors (e.g., black text on a white background).

(4) *Location.* The identification label shall be visible from the back of the unit when the unit is fully assembled.

(5) *Permanency.* The identification label shall be legible and attached after it is tested using the methods specified in Section 7.3 of ASTM F2057-19, *Standard Safety Specification for Clothing Storage Units* (incorporated by reference, see paragraph (c) of this section).

(c) *Incorporation by reference.* Certain portions, identified in this section, of ASTM F2057-19, *Standard Safety Specification for Clothing Storage Units*, approved on August 1, 2019, are incorporated by reference into this part with the approval of the Director of the Federal Register in accordance with 5

U.S.C. 552(a) and 1 CFR part 51. You may obtain a copy from ASTM International, 100 Barr Harbor Drive, PO Box C700, West Conshohocken, PA 19428-2959; phone: (610) 832-9585; [www.astm.org](http://www.astm.org). A read-only copy of the standard is available for viewing on the ASTM website at <https://www.astm.org/READINGLIBRARY/>. You may inspect a copy at the Division of the Secretariat, U.S. Consumer Product Safety Commission, 4330 East-West Highway, Bethesda, MD 20814, telephone (301) 504-7479, email: [cpsc-os@cpsc.gov](mailto:cpsc-os@cpsc.gov), or at the National Archives and Records Administration (NARA). For information on the availability of this material at NARA, email [fr.inspection@nara.gov](mailto:fr.inspection@nara.gov), or go to: [www.archives.gov/federal-register/cfr/ibr-locations.html](http://www.archives.gov/federal-register/cfr/ibr-locations.html).

**§ 1261.6 Requirements to provide performance and technical data by labeling.**

Manufacturers of clothing storage units shall give notification of performance and technical data related to performance and safety to prospective purchasers of such products at the time of original purchase and to the first purchaser of such product for purposes other than resale, in the manner set forth in this section:

(a) *Consumer information requirements.* The manufacturer shall provide a hang tag with every clothing storage unit that provides the ratio of tip-over moment as tested to the minimally allowed tip-over moment of that model clothing storage unit. The label must conform in content, form, and sequence to the hang tag shown in figure 1 to this paragraph (a).

(1) *Size.* Every hang tag shall be at least 5 inches wide by 7 inches tall.

(2) *Side 1 Content.* The front of every hang tag shall contain the following:

- (i) The title—“TIP OVER GUIDE.”
- (ii) The icon:

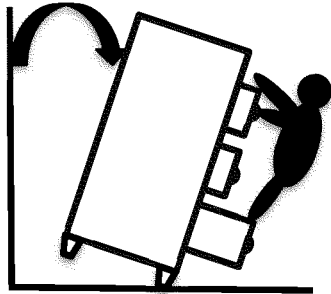

(iii) The statement—“Stability Rating.”

(iv) The manufacturer’s name and model number of the unit.

(v) Ratio of tip-over moment, as tested per § 1261.4(c), to the threshold moment, as determined per § 1261.4(d), of that model clothing storage unit, displayed on a progressive scale. This value shall be the rating.

(vi) The scale shall start at 0 and end at 5.

(vii) “Less” and “More” on the left and right sides of the scale, respectively.

(viii) A rating of 1 shall be indicated by the text “Minimum rating” and a vertical dotted line.

(ix) A solid horizontal line from 0 to the calculated rating.

(x) The statement—“Compare with other units before you buy.”

(xi) The statement—“This is a guide to compare the unit’s resistance to tipping over.”

(xii) The statement—“Higher numbers represent more stable units.”

(xiii) The statement—“No unit is completely safe from tip over.”

(xiv) The statement—“Always secure the unit to the wall.”

(xv) The statement—“Tell children not to climb furniture.”

(xvi) The statement—“See back side of this tag for more information.”

(xvii) The statement—“THIS TAG NOT TO BE REMOVED EXCEPT BY THE CONSUMER.”

(3) *Side 2 Content.* The reverse of every hang tag shall contain the following:

(i) The statement—“Stability Rating Explanation.”

(ii) The icon in paragraph (a)(2)(ii) of this section.

(iii) The tip rating determined in paragraph (a)(2)(v) of this section.

(iv) The statement—“Test data on this unit indicated it withstood [insert rating determined in paragraph (a)(2)(v) of this section] times the minimally acceptable moment, per tests required by the Consumer Product Safety Commission (see below).”

(v) The statement—“Deaths or serious crushing injuries have occurred from furniture tipping over onto people.”

(vi) The statement—“To reduce tip-over incidents, the U.S. Consumer Product Safety Commission (CPSC) requires that clothing storage units, such as dressers, chests, bureaus, and armoires, resist certain tip-over forces.

The test that CPSC requires measures the stability of a clothing storage unit and its resistance to rotational forces, also known as moments. This test is based on threshold rotational forces of a 3-year-old child climbing up, hanging on, or pulling on drawers and/or doors of this unit. These actions create rotational forces (moments) that can cause the unit to tip forward and fall over. The stability rating on this tag is the ratio of this unit’s tip-over moment (using CPSC’s test) and the threshold tip-over moment. More information on the test method can be found in 16 CFR part 1261.”

(4) *Format.* The hang tag shall be formatted as shown in Figure 9. The background of the front of the tag shall be printed in full bleed process yellow or equivalent; the background of the back of the tag shall be white. All type and graphics shall be printed in process black.

(5) *Attachment.* Every hang tag shall be attached to the CSU and be clearly visible to a person standing in front of the unit. The hang tag shall be attached to the CSU and lost or damaged hang tags must be replaced such that they are attached and provided, as required by this section, at the time of original purchase to prospective purchasers and to the first purchaser other than resale. The hang tags may be removed only by the first purchaser.

(6) *Placement.* The hang tag shall appear on the product and the immediate container of the product in which the product is normally offered for sale at retail. Ready-to-assemble furniture shall display the hang tag on the main panel of consumer-level packaging. The hang tag shall remain on the product/container/packaging until the time of original purchase. Any units shipped directly to consumers shall contain the hang tag on the immediate container of the product.

**BILLING CODE 6355-01-P**

Figure 1 to paragraph (a)—Hang tag example shown for a unit with a tip rating of 2.8.

FRONT

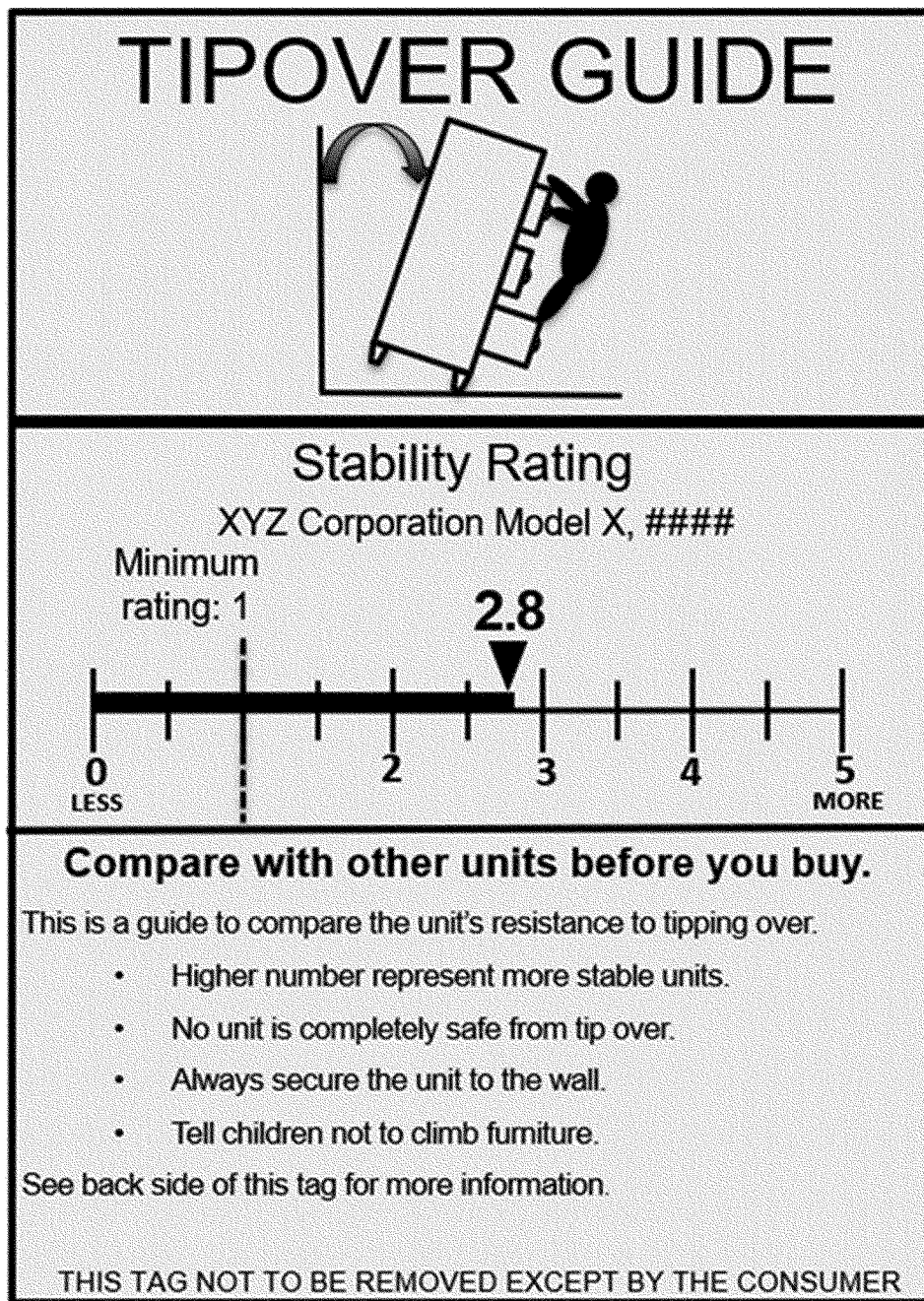

REVERSE

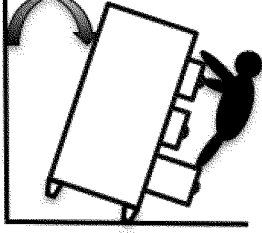
<p><b>Stability Rating: 2.8</b></p>	
<h2>Stability Rating Explanation</h2> <p>Test data on this unit indicated it withstood <b>2.8 times</b> the threshold tip over rotational force/moment, per tests required by the Consumer Product Safety Commission (see below)</p> <p><b>Deaths and serious crushing injuries have occurred from furniture tipping over onto people.</b></p> <p>To reduce tip-over incidents, the U.S. Consumer Product Safety Commission (CPSC) requires that clothing storage units, such as dressers, chests, bureaus, and armoires, resist certain tip-over forces. The test that CPSC requires measures the stability of a clothing storage unit and its resistance to rotational forces, also known as moments. This test is based on threshold rotational forces of 3-year-old child climbing up, hanging on, or pulling on drawers and/or doors of this unit. These actions create rotational forces (moments) that can cause the unit to tip forward and fall over. The stability rating on this tag is the ratio of this unit's tip-over moment (using CPSC's test) and the threshold tip-over moment. More information on the test method can be found in 16 CFR XXXX.</p>	

BILLING CODE 6355-01-C

(b) [Reserved]

**§ 1261.7 Prohibited stockpiling.**

(a) *Prohibited acts.* Manufacturers and importers of clothing storage units shall not manufacture or import clothing storage units that do not comply with the requirements of this part in any 1-month period between [DATE OF PUBLICATION OF FINAL RULE] and [EFFECTIVE DATE OF FINAL RULE] at a rate that is greater than 105 percent of the rate at which they manufactured or imported clothing storage units during the *base period* for the manufacturer.

(b) *Base period.* The base period for clothing storage units is the calendar month with the median manufacturing or import volume within the last 13 months immediately preceding the month of promulgation of the final rule.

**§ 1261.8 Findings.**

(a) *General.* Section 9(f) of the Consumer Product Safety Act (15 U.S.C. 2058(f)) requires the Commission to make findings concerning the following topics and to include the findings in the rule. Because the findings are required to be published in the rule, they reflect the information that was available to the Consumer Product Safety Commission (Commission, CPSC) when the standard was issued on [DATE OF PUBLICATION OF FINAL RULE].

(b) *Degree and nature of the risk of injury.* The standard is designed to reduce the risk of death an injury from clothing storage units tipping over onto children. The Commission has identified 193 clothing storage unit tip-over fatalities to children that were reported to have occurred between January 1, 2000 and December 31, 2020. There were an estimated 56,400 injuries,

an annual average of 4,000 estimated injuries, to children related to clothing storage unit tip overs that were treated in U.S. hospital emergency departments from January 1, 2006 to December 31, 2019. Injuries to children, resulting from clothing storage units tipping over, include soft tissue injuries, skeletal injuries and bone fractures, and fatalities resulting from skull fractures, closed-head injuries, compressional and mechanical asphyxia, and internal organ crushing leading to hemorrhage.

(c) *Number of consumer products subject to the rule.* In 2017, there were approximately 463.5 million clothing storage units in use. In 2018, combined shipments of dressers and chests totaled 43.6 million units. Annual sales of clothing storage units total about 44 million units.

(d) *The need of the public for clothing storage units and the effects of the rule*

on their cost, availability, and utility. (1) Consumers commonly use clothing storage units to store clothing in their homes. The standard requires clothing storage units to meet a minimum stability threshold, but does not restrict the design of clothing storage units. As such, clothing storage units that meet the standard would continue to serve the purpose of storing clothing in consumers' homes. There may be a negative effect on the utility of clothing storage units if products that comply with the standard are less convenient to use. Another potential effect on utility could occur if, in order to comply with the standard, manufacturers modify clothing storage units to eliminate certain desired characteristics or styles, or discontinue models. However, this loss of utility would be mitigated to the extent that other clothing storage units with similar characteristics and features are available that comply with the standard.

(2) Retail prices of clothing storage units vary widely. The least expensive units retail for less than \$100, while some more expensive units retail for several thousand dollars. Of the potential modifications to comply with the standard for which CPSC was able to estimate the potential cost, the lowest costs were about \$5.80 per unit; however, several were significantly higher. Clothing storage unit prices may increase to reflect the added cost of modifying or redesigning products to comply with the standard, or to account for increased distribution costs. In addition, consumers may incur a cost in the form of additional time to assemble clothing storage units if additional safety features are included.

(3) If the costs associated with redesigning or modifying a clothing storage unit model to comply with the standard results in the manufacturer discontinuing that model, there would be some loss in availability of clothing storage units.

(e) *Other means to achieve the objective of the rule while minimizing adverse effects on competition, manufacturing, and commercial practices.* (1) The Commission considered alternatives to achieving the objective of the rule of reducing unreasonable risks of injury and death associated with clothing storage unit tip overs. For example, the Commission considered relying on voluntary recalls, compliance with the voluntary standard, and education campaigns, rather than issuing a standard. This alternative would have minimal costs; however, it is unlikely to further reduce the risk of injury from clothing storage

unit tip overs because the Commission has relied on these efforts to date.

(2) The Commission also considered issuing a standard that requires only performance and technical data, with no performance requirements for stability. This would impose lower costs on manufacturers, but is unlikely to adequately reduce the risk of injury from clothing storage unit tip overs because it relies on manufacturers choosing to offer more stable units; consumer assessment of their need for more stable units (which CPSC's research indicates consumers underestimate); and does not account for units outside a child's home or purchased before a child was born.

(3) The Commission also considered mandating a standard like the voluntary standard, but replacing the 50-pound test weight with a 60-pound test weight. This alternative would be less costly than the proposed rule, because many clothing storage units already meet such a requirement, and it would likely cost less to modify noncompliant units to meet this less stringent standard. However, this alternative is unlikely to adequately reduce the risk of clothing storage unit tip overs because it does not account for factors that are present in tip-over incidents that contribute to clothing storage unit instability, including multiple open and filled drawers, carpeting, and forces generated by a child interacting with the unit.

(4) Another alternative the Commission considered was providing a longer effective date. This may reduce the costs of the rule by spreading them over a longer period, but it would also delay the benefits of the rule, in the form of reduced deaths and injuries.

(5) Another alternative the Commission considered is adopting a mandatory standard with the requirements in the proposed rule, but addressing 60-pound children, rather than 51.2-pound children. However, this alternative would be more stringent than the proposed rule and, therefore, would likely increase the costs associated with the rule, while only increasing the benefits of the rule by about 4.5 percent.

(f) *Unreasonable risk.* (1) Incident data indicates that there were 226 reported tip-over fatalities involving clothing storage units that were reported to have occurred between January 1, 2000 and December 31, 2020, of which 85 percent (193 incidents) were children, 5 percent (11 incidents) were adults, and 10 percent (22 incidents) were seniors. Of the reported child fatalities, 86 percent (166 fatalities) involved children 3 years old or younger.

(2) There were an estimated 78,200 injuries, an annual average of 5,600 estimated injuries, related to clothing storage unit tip overs that were treated in U.S. hospital emergency departments from January 1, 2006 to December 31, 2019. Of these, 72 percent (56,400) were to children, which is an annual average of 4,000 estimated injuries to children over the 14-year period. In addition, there were approximately 19,300 tip-over injuries involving clothing storage units treated in other settings from 2015 through 2019, or an average of 3,900 per year. Therefore, combined, there were an estimated 34,100 nonfatal, medically attended tip-over injuries to children from clothing storage units during the years 2015 through 2019.

(3) Injuries to children when clothing storage units tip over can be serious. They include fatal injuries resulting from skull fractures, closed-head injuries, compressional and mechanical asphyxia, and internal organ crushing leading to hemorrhage; they also include serious nonfatal injuries, including skeletal injuries and bone fractures.

(g) *Public interest.* This rule is intended to address an unreasonable risk of injury and death posed by clothing storage units tipping over. The Commission believes that adherence to the requirements of the rule will significantly reduce clothing storage unit tip-over deaths and injuries in the future; thus, the rule is in the public interest.

(h) *Voluntary standards.* The Commission is aware of four voluntary and international standards that are applicable to clothing storage units: ASTM F2057–19, *Standard Consumer Safety Specification for Clothing Storage Units*; AS/NZS 4935: 2009, the Australian/New Zealand Standard for *Domestic furniture—Freestanding chests of drawers, wardrobes and bookshelves/bookcases—determination of stability*; ISO 7171 (2019), the International Organization for Standardization *International Standard for Furniture—Storage Units—Determination of stability*; and EN14749 (2016), the European Standard, *European Standard for Domestic and kitchen storage units and worktops—Safety requirements and test methods*. The Commission does not consider the standards adequate because they do not account for the multiple factors that are commonly present simultaneously during clothing storage unit tip-over incidents and that testing indicates decrease the stability of clothing storage units. These factors include multiple open and filled drawers, carpeted flooring, and dynamic forces generated



by children's interactions with the clothing storage unit, such as climbing or pulling on the top drawer.

(i) *Relationship of benefits to costs.* The aggregate net benefits of the rule are estimated to be about \$305.5 million annually; and the cost of the rule is estimated to be about \$250 million annually. On a per unit basis, the Commission estimates the expected benefits per unit to be \$6.01, assuming a 7 percent discount rate; \$7.88 assuming a 3 percent discount rate; and \$9.90 without discounting. The Commission estimates the expected costs to manufacturers per unit to be \$5.80 (based on the lowest estimated potential cost), plus an unquantifiable cost to consumers associated with lost utility and availability, and increased costs. Based on this analysis, the Commission preliminarily finds that the benefits expected from the rule bear a reasonable relationship to the anticipated costs of the rule.

(j) *Least burdensome requirement that would adequately reduce the risk of injury.* (1) The Commission considered less-burdensome alternatives to the proposed rule, but preliminarily concluded that none of these alternatives would adequately reduce the risk of injury.

(2) The Commission considered relying on voluntary recalls, compliance

with the voluntary standard, and education campaigns, rather than issuing a mandatory standard. This alternative would be less burdensome by having minimal costs, but would be unlikely to reduce the risk of injury from clothing storage unit tip overs. The Commission has relied on these efforts to date, but despite these efforts, there has been no declining trend in child injuries from clothing storage unit tip overs (without televisions) from 2006 to 2019.

(3) The Commission considered issuing a standard that requires only performance and technical data, with no performance requirements for stability. This would be less burdensome by imposing lower costs on manufacturers, but is unlikely to adequately reduce the risk of injury because it relies on manufacturers choosing to offer more stable units; consumer assessment of their need for more stable units (which CPSC's research indicates consumers underestimate); and does not account for clothing storage units outside a child's home or purchased before a child was born.

(4) The Commission considered mandating a standard like ASTM F2057-19, *Standard Consumer Safety Specification for Clothing Storage Units*, but replacing the 50-pound test weight

with a 60-pound test weight. This alternative would be less burdensome in terms of costs than the proposed rule, because many clothing storage units already meet such a requirement, and it would likely cost less to modify noncompliant units to meet this less stringent standard. However, this alternative is unlikely to adequately reduce the risk of tip overs because it does not account for several factors that are simultaneously present in clothing storage unit tip-over incidents and contribute to instability, including multiple open and filled drawers, carpeting, and forces generated by a child interacting with the unit.

(5) The Commission considered providing a longer effective date. This may reduce the cost burden of the rule by spreading the costs over a longer period, but it would also delay the benefits of the rule, in the form of reduced deaths and injuries.

(6) Therefore, the Commission concludes that the rule is the least burdensome requirement that would adequately reduce the risk of injury.

**Alberta E. Mills,**

*Secretary, Consumer Product Safety Commission.*

[FR Doc. 2022-01689 Filed 2-2-22; 8:45 am]

**BILLING CODE 6355-01-P**



# FEDERAL REGISTER

---

Vol. 87

Thursday,

No. 23

February 3, 2022

---

Part III

## Environmental Protection Agency

---

40 CFR Parts 87, 1030, and 1031

Control of Air Pollution From Aircraft Engines: Emission Standards and Test Procedures; Proposed Rule

## ENVIRONMENTAL PROTECTION AGENCY

### 40 CFR Parts 87, 1030, and 1031

[EPA-HQ-OAR-2019-0660; FRL-7558-01-OAR]

RIN 2060-AU69

### Control of Air Pollution From Aircraft Engines: Emission Standards and Test Procedures

**AGENCY:** Environmental Protection Agency (EPA).

**ACTION:** Proposed rule.

**SUMMARY:** The Environmental Protection Agency (EPA) is proposing particulate matter (PM) emission standards and test procedures applicable to certain classes of engines used by civil subsonic jet airplanes (those engines with rated output of greater than 26.7 kilonewtons (kN)) to replace the existing smoke standard for aircraft. These proposed standards and test procedures are equivalent to the engine standards adopted by the United Nations' International Civil Aviation Organization (ICAO) in 2017 and 2020 and would apply to both new type design aircraft engines and in-production aircraft engines. The EPA, as well as the United States Federal Aviation Administration (FAA), actively participated in the ICAO proceedings in which these requirements were developed. These proposed standards would reflect the importance of the control of PM emissions and U.S. efforts to secure the highest practicable degree of uniformity in aviation regulations and standards. Additionally, the EPA is proposing to migrate, modernize, and streamline the existing regulations into a new part. As part of this update, the EPA is also proposing to align with ICAO by applying the smoke number standards to engines less than or equal to 26.7 kilonewtons rated output used in supersonic airplanes.

**DATES:** Comments on this proposal must be received on or before April 4, 2022.

**Public hearing:** EPA will announce the public hearing date and location for this proposal in a supplemental **Federal Register** document.

**ADDRESSES:**

**Comments:** EPA solicits comments on all aspects of the proposed standards.

**Written comments:** Submit your comments, identified by Docket ID No. EPA-HQ-OAR-2019-0660, at <https://www.regulations.gov>. Follow the online instructions for submitting comments. Once submitted, comments cannot be edited or removed from *Regulations.gov*. The EPA may publish any comment

received to its public docket. Do not submit electronically any information you consider to be Confidential Business Information (CBI) or other information whose disclosure is restricted by statute. Multimedia submissions (audio, video, etc.) must be accompanied by a written comment. The written comment is considered the official comment and should include discussion of all points you wish to make. The EPA will generally not consider comments or comment contents located outside of the primary submission (*i.e.*, on the web, cloud, or other file sharing system). For additional submission methods, the full EPA public comment policy, information about CBI or multimedia submissions, and general guidance on making effective comments, please visit <https://www.epa.gov/dockets/commenting-epa-dockets>.

The EPA is temporarily suspending its Docket Center and Reading Room for public visitors, with limited exceptions, to reduce the risk of transmitting COVID-19. Our Docket Center staff will continue to provide remote customer service via email, phone, and webform. We encourage the public to submit comments via <https://www.regulations.gov> as there may be a delay in processing mail and faxes. For further information and updates on EPA Docket Center services, please visit us online at <https://www.epa.gov/dockets>.

The EPA continues to carefully and continuously monitor information from the Centers for Disease Control and Prevention (CDC), local area health departments, and our Federal partners so that we can respond rapidly as conditions change regarding COVID-19.

**Docket:** EPA has established a docket for the action under Docket ID No. EPA-HQ-OAR-2019-0660. All documents in the docket are listed on the [www.regulations.gov](https://www.regulations.gov) website. Although listed in the index, some information is not publicly available, *e.g.*, confidential business information or other information whose disclosure is restricted by statute. Certain other material, such as copyrighted material is not placed on the internet and will be publicly available only in hard copy form. Publicly available docket materials are available either electronically through [www.regulations.gov](https://www.regulations.gov) or in hard copy at the following location:

Air and Radiation Docket and Information Center, EPA Docket Center, EPA/DC, EPA WJC West Building, 1301 Constitution Ave. NW, Room 3334, Washington, DC.

Out of an abundance of caution for members of the public and our staff, the

EPA Docket Center and Reading Room was closed to public visitors on March 31, 2020, to reduce the risk of transmitting COVID-19. Our Docket Center staff will continue to provide remote customer service via email, phone, and webform. We encourage the public to submit comments via <https://www.regulations.gov> or email, as there is a temporary suspension of mail delivery to EPA, and no hand deliveries are currently accepted. For further information on EPA Docket Center services and the current status, please visit us online at <https://www.epa.gov/dockets>.

**FOR FURTHER INFORMATION CONTACT:**

Bryan Manning, Office of Transportation and Air Quality, Assessment and Standards Division (ASD), Environmental Protection Agency, 2000 Traverwood Drive, Ann Arbor, MI 48105; telephone number: (734) 214-4832; email address: [manning.bryan@epa.gov](mailto:manning.bryan@epa.gov).

**SUPPLEMENTARY INFORMATION:**

**Table of Contents**

- I. General Information
  - A. Does this action apply to me?
  - B. Executive Summary
    - 1. Summary of the Major Provisions of the Proposed Regulatory Action
    - 2. Purpose of the Proposed Regulatory Action
    - 3. Environmental Justice
- II. Introduction: Context for This Proposed Action
  - A. EPA Statutory Authority and Responsibilities Under the Clean Air Act
  - B. The Role of the United States in International Aircraft Agreements
  - C. The Relationship Between EPA's Regulation of Aircraft Engine Emissions and International Standards
- III. Particulate Matter Impacts on Air Quality and Health
  - A. Background on Particulate Matter
  - B. Health Effects of Particulate Matter
  - C. Environmental Effects of Particulate Matter
    - 1. Deposition of Metallic and Organic Constituents of PM
    - 2. Materials Damage and Soiling
    - D. Near-Source Impacts on Air Quality and Public Health
    - E. Contribution of Aircraft Emissions to PM in Selected Areas
    - F. Other Pollutants Emitted by Aircraft
    - G. Environmental Justice
- IV. Details for the Proposed Rule
  - A. PM Mass Standards for Aircraft Engines
    - 1. Applicability of Standards
    - 2. New Type nvPM Mass Numerical Emission Limits for Aircraft Engines
    - 3. In Production nvPM Mass Numerical Emission Limits for Aircraft Engines
    - 4. Graphical representation of nvPM Mass Numerical Emission Limits
  - B. PM Number Standards for Aircraft Engines
    - 1. Applicability of Standards

- 2. New Type nvPM Number Numerical Emission Limits for Aircraft Engines
- 3. In Production nvPM Number Numerical Emission Limits for Aircraft Engines
- 4. Graphical representation of nvPM Number Numerical Emission Limits
- C. PM Mass Concentration Standard for Aircraft Engines
  - 1. PM Mass Concentration Standard
  - 2. Graphical Representation of nvPM Mass Concentration Numerical Emission Limit
- D. Test and Measurement Procedures
  - 1. Aircraft Engine PM Emissions Metrics
  - 2. Test Procedure
  - 3. Test Duty Cycles
  - 4. Characteristic Level
  - 5. Derivative Engines for Emissions Certification Purposes
- E. Annual Reporting Requirement
- V. Aggregate PM Inventory Impacts
  - A. Aircraft Engine PM Emissions for Modeling
    - 1. Baseline PM Emission Indices
    - 2. Measured nvPM EIs for Inventory Modeling
    - 3. Improvements to Calculated EIs
  - B. Baseline PM Emission Inventory
  - C. Projected Reductions in PM Emissions

- VI. Technological Feasibility and Economic Impacts
  - A. Market Considerations
  - B. Conceptual Framework for Technology
  - C. Technological Feasibility
  - D. Costs Associated With the Proposed Rule
  - E. Summary of Benefits and Costs
- VII. Technical Amendments
  - A. Migration of Regulatory Text to New Part
  - B. Deletion of Unnecessary Provisions
  - C. Other Technical Amendments and Minor Changes
- VIII. Statutory Authority and Executive Order Reviews
  - A. Executive Order 12866: Regulatory Planning and Review and Executive Order 13563: Improving Regulation and Regulatory Review
  - B. Paperwork Reduction Act (PRA)
  - C. Regulatory Flexibility Act (RFA)
  - D. Unfunded Mandates Reform Act (UMRA)
  - E. Executive Order 13132: Federalism
  - F. Executive Order 13175: Consultation and Coordination With Indian Tribal Governments

- G. Executive Order 13045: Protection of Children From Environmental Health Risks and Safety Risks
- H. Executive Order 13211: Actions Concerning Regulations That Significantly Affect Energy Supply, Distribution or Use
- I. National Technology Transfer and Advancement Act (NTTAA)
- J. Executive Order 12898: Federal Actions To Address Environmental Justice in Minority Populations and Low-Income Populations

**I. General Information**

*A. Does this action apply to me?*

This proposed action would affect companies that design and or manufacture civil subsonic jet aircraft engines with a rated output of greater than 26.7 kN and those that design and or manufacturer civil jet engines for use on supersonic airplanes with a rated output at or below 26.7 kN. These affected entities include the following:

Category	NAICS code <sup>a</sup>	Examples of potentially affected entities
Industry .....	336412	Manufacturers of new aircraft engines.

<sup>a</sup> North American Industry Classification System (NAICS).

This table lists the types of entities that EPA is now aware could potentially be affected by this action. Other types of entities not listed in the table could also be regulated. To determine whether your activities are regulated by this action, you should carefully examine the relevant applicability criteria in 40 CFR parts 87 and 1031. If you have any questions regarding the applicability of this action to a particular entity, consult the person listed in the preceding **FOR FURTHER INFORMATION CONTACT** section.

For consistency purposes across the United States Code of Federal Regulations (CFR), common definitions for the words “airplane,” “aircraft,” “aircraft engine,” and “civil aircraft” are found in Title 14 CFR part 1, and are used as appropriate throughout this new proposed regulation under 40 CFR parts 87 and 1031.

*B. Executive Summary*

**1. Summary of the Major Provisions of the Proposed Regulatory Action**

The EPA is proposing to regulate PM emissions from covered aircraft engines through the adoption of domestic PM regulations that match the ICAO PM standards, which would be implemented and enforced in the U.S. The proposed standards would apply to new type design and in-production aircraft engines with rated output (maximum thrust available for takeoff)

of greater than 26.7 kN used by civil subsonic jet airplanes: Those engines generally used in commercial passenger and freight aircraft, as well as larger business jets. The EPA is proposing to adopt three different forms of PM standards: A PM mass standard in milligrams per kilonewton (mg/kN), a PM number standard in number of particles per kilonewton (#/kN), and a PM mass concentration standard in micrograms per cubic meter (µg/m<sup>3</sup>). The applicable dates and coverage of these standards would vary, as described in the following paragraphs, and more fully in in IV.A, IV.B, and IV.C respectively.

First, the EPA is proposing PM engine emissions standards, in the form of both PM mass (mg/kN) and PM number (#/kN), for new type designs and in-production aircraft turbofan and turbojet engines with rated output greater than 26.7 kN. The proposed standards for in-production engines would apply to those engines that would be manufactured on or after January 1, 2023, even if type certificated before that date. The proposed standards for new type designs would apply to those engines whose initial type certification application was submitted on or after January 1, 2023. The in-production standards would have different emission levels limits than would the standards for new type designs. The

different emission levels limits for new type designs and in-production engines would depend on the rated output of the engines. Compliance with the proposed PM mass and number standards would be done in accordance with the standard landing and take-off (LTO) test cycle, which is currently used for demonstrating compliance with gaseous emission standards (oxides of nitrogen (NO<sub>x</sub>), hydrocarbons (HC), and carbon monoxide (CO) standards) for the covered engines.

Second, the EPA is proposing a PM engine emissions standard in the form of maximum mass concentration (µg/m<sup>3</sup>) for in-production aircraft turbofan and turbojet engines with rated output greater than 26.7 kN manufactured on or after January 1, 2023.<sup>1</sup> Compliance with the PM mass concentration standard would be done using the same test data that is developed to demonstrate compliance with the LTO-based PM mass and number standards. The proposed PM mass concentration standard would apply to the highest concentration of PM measured across the engine operating thrust range, not

<sup>1</sup> The implementation date for ICAO’s PM maximum mass concentration standards is on or after January 1, 2020. The final rulemaking that would follow this proposed rulemaking for these standards is expected to be completed before January 1, 2023. Thus, the standards would have an implementation date of January 1, 2023 (instead of January 1, 2020).

just at one of the four LTO thrust settings.

The proposed PM mass concentration standard was developed by ICAO to provide, through a PM mass measurement, the equivalent smoke opacity or visibility control as afforded by the existing smoke number standard for the covered engines. Thus, the EPA is also proposing to no longer apply the existing smoke number standard for new engines that would be subject to the proposed PM mass concentration standard after January 1, 2023, but the EPA is maintaining smoke number standards for new engines not covered by the PM mass concentration standard (e.g., in-production aircraft turbofan and turbojet engines with rated output less than or equal to 26.7 kN) and for engines already manufactured. This proposed approach would essentially change the existing standard for covered engines from being based on a smoke measurement to a PM measurement.

Third, the EPA is proposing testing and measurement procedures for the PM emission standards and various updates to the existing gaseous exhaust emissions test procedures. These proposed test procedure provisions would implement the recent additions and amendments to ICAO's regulations, which are codified in ICAO Annex 16, Volume II. As we have historically done, we propose to incorporate these test procedure additions and amendments to the ICAO Annex 16, Volume II into our regulations by reference.

The proposed aircraft engine PM standards, test procedures and associated regulatory requirements are equivalent to the international PM standards and test procedures adopted by ICAO in 2017 and 2020 and promulgated in Annex 16, Volume II.<sup>2</sup> The United States and other member States of ICAO, as well as the world's aircraft engine manufacturers and other interested stakeholders, participated in the deliberations leading up to ICAO's adoption of the international aircraft engine PM emission standards.

In addition to the PM standards just discussed, the EPA is proposing to

migrate the existing aircraft engine emissions regulations from 40 CFR part 87 to a new 40 CFR part 1031, and all the aircraft engine standards and requirements described earlier would be specified in this new part 1031. Along with this migration, the EPA is proposing to restructure the regulations to allow for better ease of use and allow for more efficient future updates. The EPA is also proposing to delete some unnecessary definitions and regulatory provisions. Finally, the EPA is proposing several other minor technical amendments to the regulations, including applying smoke number standards to engines of less than or equal to 26.7 kilonewtons (kN) rated output used in supersonic airplanes.

## 2. Purpose of the Proposed Regulatory Action

In developing these proposed standards, the EPA took into consideration the importance of both controlling PM emissions and international harmonization of aviation requirements. In addition, the EPA gave significant weight to the U.S.'s treaty obligations under the Chicago Convention, as discussed in Section II.B, in determining the need for and appropriate levels of PM standards. These considerations led the EPA to propose standards for PM emissions from certain classes of covered aircraft engines that are equivalent in scope, stringency, and effective date to the PM standards adopted by ICAO.

The new ICAO aircraft PM emission standards will take effect on January 1, 2023 but will not apply in the U.S. unless adopted into domestic law. One of the core functions of ICAO is to adopt Standards and Recommended Practices on a wide range of aviation-related matters, including aircraft emissions. As a member State of ICAO, the United States actively participates in the development of new environmental standards, within ICAO's Committee on Aviation Environmental Protection (CAEP), including the PM standards adopted by ICAO in both 2017 and 2020. Due to the international nature of the aviation industry, there is an advantage to working within ICAO, in order to secure the highest practicable degree of uniformity in international aviation regulations and standards. Uniformity in international aviation regulations and standards is a goal of the Chicago Convention, because it ensures that passengers and the public can expect similar levels of protection for safety and human health and the environment regardless of manufacturer, airline, or point of origin of a flight. Further, it helps reduce barriers in the

global aviation market, benefiting both U.S. aircraft engine manufacturers and consumers.

When developing new emissions standards, ICAO/CAEP seeks to capture the technological advances made in the control of emissions through the adoption of anti-backsliding standards reflecting the current state of technology. The PM standards the EPA is proposing were developed using this approach. Thus, the adoption of these aviation standards into U.S. law would simultaneously prevent aircraft engine PM levels from increasing beyond their current levels, align U.S. domestic standards with the ICAO standards for international harmonization, and help the U.S. meet its treaty obligations under the Chicago Convention.

These proposed standards would also allow U.S. manufacturers of covered aircraft engines to remain competitive in the global marketplace (as described later in the introductory text of Section IV). In the absence of U.S. standards implementing the ICAO aircraft engine PM emission standards, U.S. civil aircraft engine manufacturers could be forced to seek PM emissions certification from an aviation certification authority of another country (not the FAA) in order to market and operate their aircraft engines internationally. U.S. manufacturers could be at a significant disadvantage if the U.S. fails to adopt standards that are at least as stringent as the ICAO standards for PM emissions. The ICAO aircraft engine PM emission standards have been or are being adopted by other ICAO member states that certify aircraft engines. The proposed action to adopt in the U.S. PM standards that match the ICAO standards would help ensure international consistency and acceptance of U.S. manufactured engines worldwide.

## 3. Environmental Justice

Executive Orders 12898 (59 FR 7629, February 16, 1994) and 14008 (86 FR 7619, February 1, 2021) direct federal agencies, to the greatest extent practicable and permitted by law, to make achieving environmental justice (EJ) part of their mission by identifying and addressing, as appropriate, disproportionately high and adverse human health or environmental effects of their programs, policies, and activities on minority populations and low-income populations in the United States. Section III.G discusses these executive orders in greater detail, along with the potential environmental justice concerns associated with exposure to aircraft PM near airports. EPA defines environmental justice as the fair

<sup>2</sup> ICAO, 2017: *Aircraft Engine Emissions, International Standards and Recommended Practices, Environmental Protection, Annex 16, Volume II, Fourth Edition, July 2017*. Available at [https://www.icao.int/publications/catalogue/cat\\_2021\\_en.pdf](https://www.icao.int/publications/catalogue/cat_2021_en.pdf) (last accessed November 15, 2021). The ICAO Annex 16 Volume II is found on page 17 of the ICAO Products & Services Catalog, English Edition of the 2021 catalog, and it is copyright protected; Order No. AN16-2. The ICAO Annex 16, Volume II, Fourth Edition, includes Amendment 10 of January 1, 2021. Amendment 10 is also found on page 17 of this ICAO catalog, and it is copyright protected; Order No. AN 16-2/E/12.

treatment and meaningful involvement of all people regardless of race, color, national origin, or income with respect to the development, implementation, and enforcement of environmental laws, regulations, and policies.

Studies have reported that many communities in close proximity to airports are disproportionately represented by people of color and low-income populations (as described later in Section III.G). In an action separate from this proposed rulemaking, EPA will be conducting an analysis of the communities residing near airports where jet aircraft operate in order to more fully understand disproportionately high and adverse human health or environmental effects on people of color, low-income populations and/or indigenous peoples. The results of this analysis could help inform additional policies to reduce pollution in communities living in close proximity to airports.

As described in Section V.C, while newer aircraft engines typically have significantly lower emissions than existing aircraft engines, the proposed standards in this action are technology-following in order to align with ICAO's standards and are not expected to, in and of themselves, result in further reductions in PM from these engines. Therefore, we do not anticipate an improvement in air quality for those who live near airports where these aircraft operate.

## II. Introduction: Context for This Proposed Action

EPA has been regulating PM emissions from aircraft engines since the 1970s when the first smoke number standards were adopted. This section provides context for the proposed rule, which proposes three PM standards for aircraft engines. This section includes a description of EPA's statutory authority, the United States' role in ICAO and developing international emission standards, and the relationship between United States' standards and ICAO's international standards.

### A. EPA Statutory Authority and Responsibilities Under the Clean Air Act

Section 231(a)(2)(A) of the Clean Air Act (CAA) directs the Administrator of EPA to, from time to time, propose aircraft engine emission standards applicable to the emission of any air pollutant from classes of aircraft engines which in his or her judgment causes or contributes to air pollution that may reasonably be anticipated to endanger public health or welfare. (See 42 U.S.C. 7571(a)(2)(A)). CAA section 231(a)(2)(B) directs the EPA to consult with the

Administrator of the Federal Aviation Administration (FAA) on such standards, and it prohibits the EPA from changing aircraft emission standards if such a change would significantly increase noise and adversely affect safety. (See 42 U.S.C. 7571(a)(2)(B)(i)–(ii)). CAA section 231(a)(3) provides that after we provide notice and an opportunity for a public hearing on standards, the Administrator shall issue such standards “with such modifications as he deems appropriate.” (See 42 U.S.C. 7571(a)(3)). In addition, under CAA section 231(b) the EPA is required to ensure, in consultation with the U.S. Department of Transportation (DOT), that the effective date of any standard provides the necessary time to permit the development and application of the requisite technology, giving appropriate consideration to the cost of compliance. (See 42 U.S.C. 7571(b)).

Consistent with its longstanding approach and D.C. Circuit precedent,<sup>3</sup> the EPA interprets its authority under CAA section 231 as providing the Administrator wide discretion in determining what standards are appropriate, after consideration of the factors specified in the statute and other relevant factors, such as applicable international standards. We are not compelled under CAA section 231 to obtain the “greatest degree of emission reduction achievable” as per sections 213(a)(3) and 202(a)(3)(A) of the CAA, and so the EPA does not interpret the Act as requiring the agency to give subordinate status to factors such as cost, safety, and noise in determining what standards are reasonable for aircraft engines. Rather, the EPA has greater flexibility under section 231 in determining what standard is most reasonable for aircraft engines. Thus, as in past rulemakings, EPA notes its authority under the CAA to issue reasonable aircraft engine standards with either technology-following or technology-forcing results, provided that, in either scenario, the Agency has a reasonable basis after considering all the relevant factors for setting the standard.<sup>4</sup> Once EPA adopts standards, CAA section 232 then directs the Secretary of Transportation to prescribe regulations to ensure compliance with the EPA's standards. (See 42 U.S.C. 7572). Finally, section 233 of the CAA

<sup>3</sup> The U.S. Court of Appeals for the D.C. Circuit has held that CAA section 231 confers an “extraordinarily broad” degree of discretion on EPA to “weigh various factors” and adopt aircraft engine emission standards as the Agency determines are reasonable. *Nat'l Ass'n of Clean Air Agencies v. EPA*, 489 F.3d 1221, 1229–30 (D.C. Cir. 2007) (NACAA).

<sup>4</sup> See 70 FR 69664, 69676 (November 17, 2005).

vests the authority to promulgate emission standards for aircraft or aircraft engines only in the Federal Government. States are preempted from adopting or enforcing any standard respecting aircraft or aircraft engine emissions unless such standard is identical to the EPA's standards. (See 42 U.S.C. 7573).

### B. The Role of the United States in International Aircraft Agreements

The Convention on International Civil Aviation (commonly known as the ‘Chicago Convention’) was signed in 1944 at the Diplomatic Conference held in Chicago. It was ratified by the United States on August 9, 1946. The Chicago Convention establishes the legal framework for the development of international civil aviation. The primary objective is “that international civil aviation may be developed in a safe and orderly manner and that international air transport services may be established on the basis of equality of opportunity and operated soundly and economically.”<sup>5</sup> In 1947, ICAO was established, and later in that same year, ICAO became a specialized agency of the United Nations (UN). ICAO sets international standards for aviation safety, security, efficiency, capacity, and environmental protection and serves as the forum for cooperation in all fields of international civil aviation. ICAO works with the Chicago Convention's member States and global aviation organizations to develop international Standards and Recommended Practices (SARPs), which member States reference when developing their domestic civil aviation regulations. The United States is one of 193 currently participating ICAO member States.<sup>6,7</sup> ICAO standards are not self-implementing. They must first be adopted into domestic law to be legally binding in any member State.

In the interest of global harmonization and international air commerce, the Chicago Convention urges its member States to “collaborate in securing the highest practicable degree of uniformity in regulations, standards, procedures and organization in relation to aircraft, [. . .] in all matters which such uniformity will facilitate and improve

<sup>5</sup> ICAO, 2006: *Convention on International Civil Aviation, Ninth Edition*, Document 7300/9. Available at: [https://www.icao.int/publications/Documents/7300\\_9ed.pdf](https://www.icao.int/publications/Documents/7300_9ed.pdf) (last accessed July 20, 2021).

<sup>6</sup> Members of ICAO's Assembly are generally termed member States or contracting States. These terms are used interchangeably throughout this preamble.

<sup>7</sup> There are currently 193 contracting states according to ICAO's website: <https://www.icao.int/MemberStates/Member%20States.English.pdf> (last accessed July 12, 2021).

air navigation.”<sup>8</sup> The Chicago Convention also recognizes that member States may adopt national standards that are more or less stringent than those agreed upon by ICAO or standards that are different in character or that comply with the ICAO standards by other means. Any member State that finds it impracticable to comply in all respects with any international standard or procedure, or that determines it is necessary to adopt regulations or practices differing in any particular respect from those established by an international standard, is required to give notification to ICAO of the differences between its own practice and that established by the international standard.<sup>9</sup>

ICAO’s work on the environment focuses primarily on those problems that benefit most from a common and coordinated approach on a worldwide basis, namely aircraft noise and engine emissions. SARPs for the certification of aircraft noise and aircraft engine emissions are covered by Annex 16 of the Chicago Convention. To continue to address aviation environmental issues, in 2004, ICAO established three environmental goals: (1) Limit or reduce the number of people affected by significant aircraft noise; (2) limit or reduce the impact of aviation emissions on local air quality; and (3) limit or reduce the impact of aviation greenhouse gas (GHG) emissions on the global climate.

The Chicago Convention has a number of other features that govern international commerce. First, member States that wish to use aircraft in international transportation must adopt emission standards that are at least as stringent as ICAO’s standards if they want to ensure recognition of their airworthiness certificates by other member States. Member States may ban the use of any aircraft within their airspace that does not meet ICAO standards.<sup>10</sup> Second, the Chicago Convention indicates that member States are required to recognize the airworthiness certificates issued or rendered valid by the contracting State

in which the aircraft is registered provided the requirements under which the certificates were issued are equal to or above ICAO’s minimum standards.<sup>11</sup> Third, to ensure that international commerce is not unreasonably constrained, a member State that cannot meet or deems it necessary to adopt regulations differing from the international standard is obligated to notify ICAO of the differences between its domestic regulations and ICAO standards.<sup>12</sup>

ICAO’s Committee on Aviation Environmental Protection (CAEP), which consists of members and observers from States, intergovernmental and non-governmental organizations representing the aviation industry and environmental interests, undertakes ICAO’s technical work in the environmental field. The Committee is responsible for evaluating, researching, and recommending measures to the ICAO Council that address the environmental impacts of international civil aviation. CAEP’s terms of reference indicate that “CAEP’s assessments and proposals are pursued taking into account: Technical feasibility; environmental benefit; economic reasonableness; interdependencies of measures (for example, among others, measures taken to minimize noise and emissions); developments in other fields; and international and national programs.”<sup>13</sup> The ICAO Council reviews and adopts the recommendations made by CAEP. It then reports to the ICAO Assembly, the highest body of the organization, where the main policies on aviation environmental protection are adopted and translated into Assembly Resolutions. If ICAO adopts a CAEP proposal for a new environmental standard, it then becomes part of ICAO standards and recommended practices (Annex 16 to the Chicago Convention).<sup>14 15</sup>

The FAA plays an active role in ICAO/CAEP, including serving as the representative (member) of the United States at annual ICAO/CAEP Steering Group meetings, as well as the ICAO/CAEP triennial meetings, and contributing technical expertise to CAEP’s working groups. The EPA serves as an advisor to the U.S. member at the annual ICAO/CAEP Steering Group and triennial ICAO/CAEP meetings, while also contributing technical expertise to CAEP’s working groups and assisting and advising the FAA on aviation emissions, technology, and environmental policy matters. In turn, the FAA assists and advises the EPA on aviation environmental issues, technology, and airworthiness certification matters.

CAEP’s predecessor at ICAO, the Committee on Aircraft Engine Emissions (CAEE), adopted the first international SARPs for aircraft engine emissions which were proposed in 1981.<sup>16</sup> These standards limited aircraft engine emissions of hydrocarbons (HC), carbon monoxide (CO), and oxides of nitrogen (NO<sub>x</sub>). The 1981 standards applied to newly manufactured engines, which are those engines manufactured after the effective date of the regulations—also referred to as in-production engines. In 1993, ICAO adopted a CAEP/2 proposal to tighten the original NO<sub>x</sub> standard by 20 percent and amend the test procedures.<sup>17</sup> These 1993 standards applied both to newly certificated turbofan engines (those engine models that received their initial type certificate after the effective date of the

the ICAO Products & Services English Edition of the 2021 catalog, and it is copyright protected; Order No. AN16-2. The ICAO Annex 16, Volume II, Fourth Edition, includes Amendment 10 of January 1, 2021. Amendment 10 is also found on page 17 of this ICAO catalog, and it is copyright protected; Order No. AN 16-2/E/12.

<sup>15</sup> CAEP develops new emission standards based on an assessment of the technical feasibility, cost, and environmental benefit of potential requirements.

<sup>16</sup> ICAO, 2017: *Aircraft Engine Emissions: Foreword*, International Standards and Recommended Practices, Environmental Protection, Annex 16, Volume II, Fourth Edition, July 2017. Available at [https://www.icao.int/publications/catalogue/cat\\_2021\\_en.pdf](https://www.icao.int/publications/catalogue/cat_2021_en.pdf) (last accessed November 15, 2021). The ICAO Annex 16 Volume II is found on page 17 of the ICAO Products & Services English Edition 2021 catalog and is copyright protected; Order No. AN16-2. The ICAO Annex 16, Volume II, Fourth Edition, includes Amendment 10 of January 1, 2021. Amendment 10 is also found on page 17 of this ICAO catalog, and it is copyright protected; Order No. AN 16-2/E/12.

<sup>17</sup> CAEP conducts its work triennially. Each 3-year work cycle is numbered sequentially and that identifier is used to differentiate the results from one CAEP meeting to another by convention. The first technical meeting on aircraft emission standards was CAEP’s predecessor, *i.e.*, CAEE. The first meeting of CAEP, therefore, is referred to as CAEP/2.

<sup>8</sup> ICAO, 2006: *Convention on International Civil Aviation, Article 37, Ninth Edition*, Document 7300/9. Available at [https://www.icao.int/publications/Documents/7300\\_9ed.pdf](https://www.icao.int/publications/Documents/7300_9ed.pdf) (last accessed July 20, 2021).

<sup>9</sup> ICAO, 2006: *Doc 7300-Convention on International Civil Aviation, Ninth Edition*, Document 7300/9. Available at [https://www.icao.int/publications/Documents/7300\\_9ed.pdf](https://www.icao.int/publications/Documents/7300_9ed.pdf) (last accessed July 20, 2021).

<sup>10</sup> ICAO, 2006: *Convention on International Civil Aviation, Article 33, Ninth Edition*, Document 7300/9. Available at [https://www.icao.int/publications/Documents/7300\\_9ed.pdf](https://www.icao.int/publications/Documents/7300_9ed.pdf) (last accessed July 20, 2021).

<sup>11</sup> ICAO, 2006: *Convention on International Civil Aviation, Article 33, Ninth Edition*, Document 7300/9. Available at [https://www.icao.int/publications/Documents/7300\\_9ed.pdf](https://www.icao.int/publications/Documents/7300_9ed.pdf) (last accessed July 20, 2021).

<sup>12</sup> ICAO, 2006: *Convention on International Civil Aviation, Article 38, Ninth Edition*, Document 7300/9. Available at [https://www.icao.int/publications/Documents/7300\\_9ed.pdf](https://www.icao.int/publications/Documents/7300_9ed.pdf) (last accessed July 20, 2021).

<sup>13</sup> ICAO: CAEP Terms of Reference. Available at <https://www.icao.int/environmental-protection/Pages/Caep.aspx#ToR> (last accessed July 20, 2021).

<sup>14</sup> ICAO, 2017: *Aircraft Engine Emissions, International Standards and Recommended Practices, Environmental Protection*, Annex 16, Volume II, Fourth Edition, July 2017. Available at [https://www.icao.int/publications/catalogue/cat\\_2021\\_en.pdf](https://www.icao.int/publications/catalogue/cat_2021_en.pdf) (last accessed November 15, 2021). The ICAO Annex 16 Volume II is found on page 17 of

regulations, also referred to as new type design engines) and to in-production engines; the standards had different effective dates for newly certificated engines and in-production engines. In 1995, CAEP/3 recommended a further tightening of the NO<sub>x</sub> standards by 16 percent and additional test procedure amendments, but in 1997 the ICAO Council rejected this stringency proposal and approved only the test procedure amendments. At the CAEP/4 meeting in 1998, the Committee adopted a similar 16 percent NO<sub>x</sub> reduction proposal, which ICAO approved in 1998. Unlike the CAEP/2 standards, the CAEP/4 standards applied only to new type design engines after December 31, 2003, and not to in-production engines, leaving the CAEP/2 standards applicable to in-production engines. In 2004, CAEP/6 recommended a 12 percent NO<sub>x</sub> reduction, which ICAO approved in 2005.<sup>18</sup> <sup>19</sup> The CAEP/6 standards applied to new engine designs certificated after December 31, 2007, again leaving the CAEP/2 standards in place for in-production engines before January 1, 2013. In 2010, CAEP/8 recommended a further tightening of the NO<sub>x</sub> standards by 15 percent for new engine designs certificated after December 31, 2013.<sup>20</sup> <sup>21</sup> The Committee also recommended that the CAEP/6 standards be applied to in-production engines on or after January 1, 2013, which cut off the production of CAEP/2 and CAEP/4 compliant engines with the exception of spare engines; ICAO adopted these as standards in 2011.<sup>22</sup>

<sup>18</sup> CAEP/5 did not address new aircraft engine emission standards.

<sup>19</sup> ICAO, 2017: *Aircraft Engine Emissions, International Standards and Recommended Practices, Environmental Protection, Annex 16, Volume II, Fourth Edition, July 2017*. Available at [https://www.icao.int/publications/catalogue/cat\\_2021\\_en.pdf](https://www.icao.int/publications/catalogue/cat_2021_en.pdf) (last accessed June 16, 2021). The ICAO Annex 16 Volume II is found on page 17 of the ICAO Products & Services Catalog, English Edition of the 2021 catalog, and it is copyright protected; Order No. AN16-2. The ICAO Annex 16, Volume II, Fourth Edition, includes Amendment 10 of January 1, 2021. Amendment 10 is also found on page 17 of this ICAO catalog, and it is copyright protected; Order No. AN 16-2/E/12.

<sup>20</sup> CAEP/7 did not address new aircraft engine emission standards.

<sup>21</sup> ICAO, 2010: *Committee on Aviation Environmental Protection (CAEP), Report of the Eighth Meeting, Montreal, February 1-12, 2010, CAEP/8-WP/80* Available in Docket EPA-HQ-OAR-2010-0687.

<sup>22</sup> ICAO, 2017: *Aircraft Engine Emissions, International Standards and Recommended Practices, Environmental Protection, Annex 16, Volume II, Fourth Edition, July 2017, Amendment 10*. CAEP/8 corresponds to Amendment 7 effective on July 18, 2011. Available at [https://www.icao.int/publications/catalogue/cat\\_2021\\_en.pdf](https://www.icao.int/publications/catalogue/cat_2021_en.pdf) (last accessed November 15, 2021). The ICAO Annex 16 Volume II is found on page 17 of the ICAO Products & Services Catalog, English Edition of the 2021 catalog, and it is copyright protected; Order No.

At the CAEP/10 meeting in 2016, the Committee agreed to the first airplane CO<sub>2</sub> emission standards, which ICAO approved in 2017. The CAEP/10 CO<sub>2</sub> standards apply to new type design airplanes for which the application for a type certificate will be submitted on or after January 1, 2020, some modified in-production airplanes on or after January 1, 2023, and all applicable in-production airplanes manufactured on or after January 1, 2028.

At the CAEP/10 and CAEP/11 meetings in 2016 and 2019, the Committee agreed to three different forms of international PM standards for aircraft engines. Maximum PM mass concentration standards were agreed to at CAEP/10, and PM mass and number standards were agreed to at CAEP/11. ICAO adopted the PM maximum mass concentration standards in 2017 and the PM mass and number standards in 2020. The CAEP/10 PM standards apply to in-production engines on or after January 1, 2020, and the CAEP/11 PM standards apply to new-type and in-production engines on or after January 1, 2023. In addition to CAEP/10 agreeing to a maximum PM mass concentration standard, CAEP/10 adopted a reporting requirement where aircraft engine manufacturers were required to provide PM mass concentration, PM mass, and PM number emissions data—and other related parameters—by January 1, 2020 for in-production engines.<sup>23</sup>

### C. The Relationship Between EPA's Regulation of Aircraft Engine Emissions and International Standards

Domestically, as required by the CAA, the EPA has been engaged in reducing harmful air pollution from aircraft engines for over 40 years, regulating gaseous exhaust emissions, smoke, and fuel venting from engines.<sup>24</sup> We have periodically revised these regulations.<sup>25</sup>

AN16-2. The ICAO Annex 16, Volume II, Fourth Edition, includes Amendment 10 of January 1, 2021. Amendment 10 is also found on page 17 of this ICAO catalog, and it is copyright protected; Order No. AN 16-2/E/12.

<sup>23</sup> More specifically, the international PM standard applies to all turbofan and turbojet engines of a type or model, and their derivative versions, with a rated output greater than 26.7 kN and whose date of manufacture of the individual engine is on or after January 1, 2020 (or those engines manufactured on or after January 1, 2020).

<sup>24</sup> U.S. EPA, 1973: *Emission Standards and Test Procedures for Aircraft*; Final Rule, 38 FR 19088 (July 17, 1973).

<sup>25</sup> The following are the most recent EPA rulemakings that revised these regulations. U.S. EPA, 1997: *Control of Air Pollution from Aircraft and Aircraft Engines; Emission Standards and Test Procedures*; Final Rule, 62 FR 25355 (May 8, 1997). U.S. EPA, 2005: *Control of Air Pollution from Aircraft and Aircraft Engines; Emission Standards and Test Procedures*; Final Rule, 70 FR 69664 (November 17, 2005). U.S. EPA, 2012: *Control of*

The EPA's actions to regulate certain pollutants emitted from aircraft engines come directly from the authority in section 231 of the CAA, and we have aligned the U.S. emissions requirements with those promulgated by ICAO. As described above in Section II.B, the ICAO/CAEP terms of reference includes technical feasibility.<sup>26</sup> Technical feasibility has been interpreted by CAEP as technology demonstrated to be safe and airworthy and available for application over a sufficient range of newly certificated aircraft.<sup>27</sup> This interpretation resulted in all previous ICAO emission standards, and the EPA's standards reflecting them, being anti-backsliding standards (*i.e.*, the standards would not reduce aircraft PM emissions below current levels of engine emissions), which are technology following.

For many years the EPA has regulated aircraft engine PM emissions through the use of smoke number standards.<sup>28</sup> Since setting the original smoke number standards in 1973, the EPA has periodically revised these standards. The EPA amended its smoke standards to align with ICAO's smoke standards in 1982<sup>29</sup> and again in 1984.<sup>30</sup> Additionally, EPA has amended the test procedures for measuring smoke

*Air Pollution from Aircraft and Aircraft Engines; Emission Standards and Test Procedures*; Final Rule, 77 FR 36342 (June 18, 2012). U.S. EPA, 2021: *Control of Air Pollution From Airplanes and Airplane Engines; GHG Emission Standards and Test Procedures*; Final Rule, 86 FR 2136 (January 11, 2021).

<sup>26</sup> ICAO: *CAEP Terms of Reference*. Available at <https://www.icao.int/environmental-protection/Pages/Caep.aspx#ToR> (last accessed July 20, 2021).

<sup>27</sup> ICAO, 2019: *Report of the Eleventh Meeting, Montreal, 4-15 February 2019*, Committee on Aviation Environmental Protection, Document 10126, CAEP11. It is found on page 26 of the English Edition of the ICAO Products & Services 2021 Catalog and is copyright protected; Order No. 10126. For purchase and available at: [https://www.icao.int/publications/catalogue/cat\\_2021\\_en.pdf](https://www.icao.int/publications/catalogue/cat_2021_en.pdf) (last accessed June 21, 2021). The statement on technological feasibility is located in Appendix C of Agenda Item 3 of this report (see page 3C-4, paragraph 2.2).

<sup>28</sup> U.S. EPA, 40 CFR 87.1. "Smoke means the matter in exhaust emissions that obscures the transmission of light, as measured by the test procedures specified in subpart G of this part." "Smoke number means a dimensionless value quantifying smoke emission as calculated according to ICAO Annex 16."

<sup>29</sup> U.S. EPA, *Control of Air Pollution From Aircraft and Aircraft Engines; Emission Standards and Test Procedures*, Final Rule, 47 FR 58462, December 30, 1982.

<sup>30</sup> U.S. EPA, *Control of Air Pollution From Aircraft and Aircraft Engines; Smoke Emission Standard*, Final Rule, 49 FR 31873, August 9, 1984 (bifurcating EPA's smoke standard for new engines into two regimes—one for engines with rated output less than 26.7 kilonewtons and one for engines with rated output equal to or greater than 26.7 kilonewtons).



emissions<sup>31</sup> and modified the effective dates and compliance schedule for smoke emissions standards periodically.<sup>32</sup> Now, we are proposing to adopt three different forms of aircraft engine PM standards: A PM mass concentration standard ( $\mu\text{g}/\text{m}^3$ ), a PM mass standard ( $\text{mg}/\text{kN}$ ), and PM number standard ( $\#/ \text{kN}$ ). These proposed aircraft engine PM emission standards are a different way of regulating and/or measuring<sup>33</sup> aircraft engine PM emissions in comparison to smoke number emission standards.

Internationally, the EPA and the FAA have worked within the standard-setting process of ICAO (CAEP and its predecessor, CAEE) since the 1970's to help establish international emission standards and related requirements, which individual member States adopt into domestic law and regulations. Historically, under this approach, international emission standards have first been adopted by ICAO, and subsequently the EPA has initiated rulemakings under CAA section 231 to establish domestic standards that are harmonized with ICAO's standards. After EPA promulgates aircraft engine emission standards, CAA section 232

requires the FAA to issue regulations to ensure compliance with the EPA aircraft engine emission standards when certificating aircraft pursuant to its authority under Title 49 of the United States Code. This proposed rule would continue this historical rulemaking approach.

The EPA and FAA worked from 2009 to 2019 within the ICAO/CAEP standard setting process on the development of the three different forms of international aircraft engine PM emission standards (a PM mass concentration standard, a PM mass standard, and a PM particle number standard). In this action, we are proposing to adopt PM standards equivalent to ICAO's three different forms of aircraft engine PM emission standards. Adoption of the proposed standards would meet the United States' obligations under the Chicago Convention and would also ensure global acceptance of FAA airworthiness certification.

In December 2018, the EPA issued an information collection request (ICR) that matches the CAEP/10 p.m. reporting requirements described earlier.<sup>34</sup> In addition to the PM standards, the proposed rulemaking would codify the reporting requirements implemented by this 2018 EPA ICR into the EPA regulations, as described later in Section IV.E. Also, in a similar time frame as this proposed rulemaking, EPA will be renewing this ICR (the ICR needs to be renewed triennially).

### III. Particulate Matter Impacts on Air Quality and Health

#### A. Background on Particulate Matter

Particulate matter (PM) is a highly complex mixture of solid particles and liquid droplets distributed among numerous atmospheric gases which interact with solid and liquid phases. Particles range in size from those smaller than 1 nanometer ( $10^{-9}$  meter) to over 100 micrometers ( $\mu\text{m}$ , or  $10^{-6}$  meter) in diameter (for reference, a typical strand of human hair is 70  $\mu\text{m}$  in diameter and a grain of salt is about 100  $\mu\text{m}$ ). Atmospheric particles can be grouped into several classes according to their aerodynamic and physical sizes. Generally, the three broad classes of particles include ultrafine particles (UFPs, generally considered as particulates with a diameter less than or equal to 0.1  $\mu\text{m}$  (typically based on physical size, thermal diffusivity or electrical mobility)), "fine" particles

(PM<sub>2.5</sub>; particles with a nominal mean aerodynamic diameter less than or equal to 2.5  $\mu\text{m}$ ), and "thoracic" particles (PM<sub>10</sub>; particles with a nominal mean aerodynamic diameter less than or equal to 10  $\mu\text{m}$ ). Particles that fall within the size range between PM<sub>2.5</sub> and PM<sub>10</sub>, are referred to as "thoracic coarse particles" (PM<sub>10-2.5</sub>, particles with a nominal mean aerodynamic diameter less than or equal to 10  $\mu\text{m}$  and greater than 2.5  $\mu\text{m}$ ).

Particles span many sizes and shapes and may consist of hundreds of different chemicals. Particles are emitted directly from sources and are also formed through atmospheric chemical reactions between PM precursors; the former are often referred to as "primary" particles, and the latter as "secondary" particles. Particle concentration and composition varies by time of year and location, and, in addition to differences in source emissions, is affected by several weather-related factors, such as temperature, clouds, humidity, and wind. Ambient levels of PM are also impacted by particles' ability to shift between solid/liquid and gaseous phases, which is influenced by concentration, meteorology, and especially temperature.

Fine particles are produced primarily by combustion processes and by transformations of gaseous emissions (e.g., sulfur oxides (SO<sub>x</sub>), nitrogen oxides (NO<sub>x</sub>) and volatile organic compounds (VOCs)) in the atmosphere. The chemical and physical properties of PM<sub>2.5</sub> may vary greatly with time, region, meteorology, and source category. Thus, PM<sub>2.5</sub> may include a complex mixture of different components including sulfates, nitrates, organic compounds, elemental carbon, and metal compounds. These particles can remain in the atmosphere for days to weeks and travel through the atmosphere hundreds to thousands of kilometers.

Particulate matter is comprised of both volatile and non-volatile PM. PM emitted from the engine is known as non-volatile PM (nvPM), and PM formed from transformation of an engine's gaseous emissions are defined as volatile PM.<sup>35</sup> Because of the

<sup>35</sup> The ICAO 2019 Environmental Report, Available at [https://www.icao.int/environmental-protection/Documents/ICAO-ENV-Report2019-F1-WEB%20\(1\).pdf](https://www.icao.int/environmental-protection/Documents/ICAO-ENV-Report2019-F1-WEB%20(1).pdf) (last accessed September 1, 2021). See pages 98, 100, and 101 for a description of non-volatile PM and volatile PM.

"During the combustion of hydrocarbon-based fuels, aircraft engines generate gaseous and particulate matter (PM) emissions. At the engine exhaust, particulate emissions consist mainly of ultrafine soot or black carbon emissions. These particles, referred to as "non-volatile" PM (nvPM), are present at high temperatures, in the engine exhaust. Compared to conventional diesel engines,

<sup>31</sup> U.S. EPA, Control of Air Pollution From Aircraft and Aircraft Engines; Emission Standards and Test Procedures, Final Rule, 62 FR 25356, May 8, 1997 (harmonizing EPA procedures with recent amendments to ICAO test procedures); U.S. EPA, Control of Air Pollution From Aircraft and Aircraft Engines; Emission Standards and Test Procedures, Final Rule, 70 FR 69664, November 17, 2005 (same); U.S. EPA, Control of Air Pollution From Aircraft and Aircraft Engines; Emission Standards and Test Procedures, Final Rule, 77 FR 36342, June 18, 2012.

<sup>32</sup> U.S. EPA, Amendment to Standards, Final Rule, 43 FR 12614, March 24, 1978 (setting back by two years the effective date for all gaseous emissions standards for newly manufactured aircraft and aircraft gas turbine engines); U.S. EPA, Control of Air Pollution from Aircraft and Aircraft Engines; Extension of Compliance Date for Emission Standards Applicable to JT3D Engines, Final Rule, 44 FR 64266, November 6, 1979 (extending the final compliance date for smoke emission standards applicable to the JT3D aircraft engines by roughly 3.5 years); U.S. EPA, Control of Air Pollution from Aircraft; Amendment to Standards, Final Rule, 45 FR 86946, December 31, 1980 (setting back by two years the effective date for all gaseous emissions standards which would otherwise have been effective on January 1, 1981, for aircraft gas turbine engines); U.S. EPA, Control of Air Pollution from Aircraft and Aircraft Engines, Final Rule, 46 FR 2044, January 8, 1981 (extending the applicability of the temporary exemption provision of the standards for smoke and fuel venting emissions from some in-use aircraft engines); U.S. EPA, Control of Air Pollution From Aircraft and Aircraft Engines; Smoke Emission Standard, Final Rule, 48 FR 46481, October 12, 1983 (staying the smoke regulations for new turbojet and turbofan engines rated below 26.7 kN thrust).

<sup>33</sup> Also, as described in Section IV.D, the proposed PM standards employ a different method for measuring aircraft engine PM emissions compared to the historical smoke number emission standards.

<sup>34</sup> 83 FR 44621, August 31, 2018. U.S. EPA, Aircraft Engines—Supplemental Information Related to Exhaust Emissions (Renewal), OMB Control Number 2060–0680, ICR Reference Number 201809–2060–08, December 17, 2018.

difficulty in measuring volatile PM, which is formed in the engine's exhaust plume and is significantly influenced by ambient conditions, the EPA is proposing standards only for the emission of nvPM.

### B. Health Effects of Particulate Matter

Scientific studies show exposure to ambient PM is associated with a broad range of health effects. These health effects are discussed in detail in the Integrated Science Assessment for Particulate Matter (PM ISA), which was finalized in December 2019.<sup>36</sup> The PM ISA concludes that human exposures to ambient PM<sub>2.5</sub> are associated with a number of adverse health effects and characterizes the weight of evidence for broad health categories (e.g., cardiovascular effects, respiratory effects, etc.).<sup>37</sup> The PM ISA additionally notes that stratified analyses (i.e., analyses that directly compare PM-related health effects across groups) provide strong evidence for racial and ethnic differences in PM<sub>2.5</sub> exposures and in PM<sub>2.5</sub>-related health risk. As described in Section III.D, concentrations of PM increase with proximity to an airport. Further, studies described in Section III.G report that many communities in close proximity to airports are disproportionately

gas turbine engines emit non-volatile particles of smaller mean diameter. Their characteristic size ranges roughly from 15 to 60 nanometers (nm; 1nm = 1/100,000 of a millimeter). These particles are invisible to the human eye and are ultrafine." (See page 98.)

"Additionally, gaseous emissions from engines can also condense to produce new particles (i.e., volatile particulate matter—vPM) or coat the emitted soot particles. Gaseous emissions species react chemically with ambient chemical constituents in the atmosphere to produce the so called secondary particulate matter. Volatile particulate matter is dependent on these gaseous precursor emissions. While these precursors are controlled by gaseous emission certification and the fuel composition (e.g., sulfur content) for aircraft gas turbine engines, the volatile particulate matter is also dependent on the ambient air background composition." (See pages 100 and 101.)

<sup>36</sup> U.S. EPA. Integrated Science Assessment (ISA) for Particulate Matter (Final Report, 2019). U.S. Environmental Protection Agency, Washington, DC, EPA/600/R-19/188, 2019.

<sup>37</sup> The causal framework draws upon the assessment and integration of evidence from across epidemiological, controlled human exposure, and toxicological studies, and the related uncertainties that ultimately influence our understanding of the evidence. This framework employs a five-level hierarchy that classifies the overall weight of evidence and causality using the following categorizations: Causal relationship, likely to be causal relationship, suggestive of a causal relationship, inadequate to infer a causal relationship, and not likely to be a causal relationship (U.S. EPA. (2009). Integrated Science Assessment for Particulate Matter (Final Report). U.S. Environmental Protection Agency, Washington, DC, EPA/600/R-08/139F, Table 1-3).

represented by people of color and low-income populations.

EPA has concluded that recent evidence in combination with evidence evaluated in the 2009 p.m. ISA supports a "causal relationship" between both long- and short-term exposures to PM<sub>2.5</sub> and mortality and cardiovascular effects and a "likely to be causal relationship" between long- and short-term PM<sub>2.5</sub> exposures and respiratory effects.<sup>38</sup> Additionally, recent experimental and epidemiologic studies provide evidence supporting a "likely to be causal relationship" between long-term PM<sub>2.5</sub> exposure and nervous system effects, and long-term PM<sub>2.5</sub> exposure and cancer. In addition, EPA noted that there was more limited and uncertain evidence for long-term PM<sub>2.5</sub> exposure and reproductive and developmental effects (i.e., male/female reproduction and fertility; pregnancy and birth outcomes), long- and short-term exposures and metabolic effects, and short-term exposure and nervous system effects resulting in the ISA concluding "suggestive of, but not sufficient to infer, a causal relationship."

More detailed information on the health effects of PM can be found in a memorandum to the docket.<sup>39</sup>

### C. Environmental Effects of Particulate Matter

Environmental effects that can result from particulate matter emissions include visibility degradation, plant and ecosystem effects, deposition effects, and materials damage and soiling. These effects are briefly summarized here and discussed in more detail in the memo to the docket cited above.

PM<sub>2.5</sub> emissions also adversely impact visibility.<sup>40</sup> In the Clean Air Act Amendments of 1977, Congress recognized visibility's value to society by establishing a national goal to protect national parks and wilderness areas from visibility impairment caused by manmade pollution.<sup>41</sup> In 1999, EPA finalized the regional haze program (64 FR 35714) to protect the visibility in Mandatory Class I Federal areas. There are 156 national parks, forests and wilderness areas categorized as Mandatory Class I Federal areas (62 FR 38680-38681, July 18, 1997). These areas are defined in CAA section 162 as

<sup>38</sup> Short term exposures are usually defined as less than 24 hours duration.

<sup>39</sup> Cook, R. Memorandum to Docket EPA-HQ-OAR-2019-0660, "Health and environmental effects of non-GHG pollutants emitted by turbine engine aircraft," August 23, 2021.

<sup>40</sup> U.S. EPA. Integrated Science Assessment (ISA) for Particulate Matter (Final Report, 2019). U.S. Environmental Protection Agency, Washington, DC, EPA/600/R-19/188, 2019.

<sup>41</sup> See Section 169(a) of the Clean Air Act.

those national parks exceeding 6,000 acres, wilderness areas and memorial parks exceeding 5,000 acres, and all international parks which were in existence on August 7, 1977. EPA has also concluded that PM<sub>2.5</sub> causes adverse effects on visibility in other areas that are not targeted by the Regional Haze Rule, such as urban areas, depending on PM<sub>2.5</sub> concentrations and other factors such as dry chemical composition and relative humidity (i.e., an indicator of the water composition of the particles). EPA established the secondary 24-hour PM<sub>2.5</sub> NAAQS in 1997 and has retained the standard in subsequent reviews.<sup>42</sup> This standard is expected to provide protection against visibility effects through attainment of the existing secondary standards for PM<sub>2.5</sub>. EPA is reconsidering the 2020 decision, as announced on June 10, 2021.<sup>43</sup>

#### 1. Deposition of Metallic and Organic Constituents of PM

Several significant ecological effects are associated with deposition of chemical constituents of ambient PM such as metals and organics.<sup>44</sup> Like all internal combustion engines, turbine engines covered by this rule may emit trace amounts of metals due to fuel contamination or engine wear. Ecological effects of PM include direct effects to metabolic processes of plant foliage; contribution to total metal loading resulting in alteration of soil biogeochemistry and microbiology, plant and animal growth and reproduction; and contribution to total organics loading resulting in bioaccumulation and biomagnification.

#### 2. Materials Damage and Soiling

Deposition of PM is associated with both physical damage (materials damage effects) and impaired aesthetic qualities (soiling effects). Wet and dry deposition of PM can physically affect materials, adding to the effects of natural weathering processes, by potentially promoting or accelerating the corrosion of metals, by degrading paints and by

<sup>42</sup> In the 2012 review of the PM NAAQS, the EPA eliminated the option for spatial averaging for the 24-hour PM<sub>2.5</sub> standard (78 FR 3086, January 15, 2013).

<sup>43</sup> <https://www.epa.gov/newsreleases/epa-reexamine-health-standards-harmful-soot-previous-administration-left-unchanged>.

<sup>44</sup> U.S. Environmental Protection Agency (U.S. EPA). 2018. Integrated Science Assessment (ISA) for Oxides of Nitrogen, Oxides of Sulfur and Particulate Matter Ecological Criteria Second External Review Draft. EPA-600-R-18-097. Washington, DC, December. Available on the internet at <https://cfpub.epa.gov/ncea/isa/recordisplay.cfm?deid=340671>.

deteriorating building materials such as stone, concrete and marble.<sup>45</sup>

#### *D. Near-Source Impacts on Air Quality and Public Health*

Airport activity can adversely impact air quality in the vicinity of airports. Furthermore, these adverse impacts may disproportionately impact sensitive subpopulations. A recent study by Yim et al. (2015) assessed global, regional, and local health impacts of civil aviation emissions, using modeling tools that address environmental impacts at different spatial scales.<sup>46</sup> The study attributed approximately 16,000 premature deaths per year globally to global aviation emissions, with 87 percent attributable to PM<sub>2.5</sub>. The study concludes that about a third of these mortalities are attributable to PM<sub>2.5</sub> exposures within 20 kilometers of an airport. Another study focused on the continental United States estimated 210 deaths per year attributable to PM<sub>2.5</sub> from aircraft.<sup>47</sup> While there are considerable uncertainties associated with such estimates, these results suggest that in addition to the contributions of PM<sub>2.5</sub> emissions to regional air quality, impacts on public health of these emissions in the vicinity of airports are an important public health concern.

A significant body of research has addressed pollutant levels and potential health effects in the vicinity of airports. Much of this research was synthesized in a 2015 report published by the Airport Cooperative Research Program (ACRP), conducted by the Transportation Research Board.<sup>48</sup> The report concluded that PM<sub>2.5</sub> concentrations in and around airports vary considerably, ranging from “relatively low levels to those that are

close to the NAAQS, and in some cases, exceeding the standards.”<sup>49</sup>

Furthermore, the report states (p. 40) that “existing studies indicate that ultrafine particle concentrations are highly elevated at an airport (*i.e.*, near a runway) with particle counts that can be orders of magnitude higher than background with some persistence many meters downwind (*e.g.*, 600 m). Finally, the report concludes that PM<sub>2.5</sub> dominates overall health risks posed by airport emissions. Moreover, one recently published study concluded that emissions from aircraft play an etiologic role in pre-term births, independent of noise and traffic-related air pollution exposures.<sup>50</sup>

Since the publication of the 2015 ACRP literature review, a number of studies conducted in the U. S. have been published which concluded that ultrafine particle number concentrations were elevated downwind of commercial airports, and that proximity to an airport also increased particle number concentrations within residences. Hudda et al. investigated ultrafine particle number concentrations (PNC) inside and outside 16 residences in the Boston metropolitan area. They found elevated outdoor PNC within several kilometers of the airport. They also found that aviation-related PNC infiltrated indoors and resulted in significantly higher indoor PNC.<sup>51</sup> In another study in the vicinity of Logan airport, Hudda et al. analyzed PNC impacts of aviation activities.<sup>52</sup> They found that, at sites 4.0 and 7.3 km from the airport, average PNCs were 2 and 1.33-fold higher, respectively, when winds were from the direction of the airport compared to other directions, indicating that aviation impacts on PNC extend many kilometers downwind of Logan airport. Stacey (2019) conducted a literature survey and concluded that

the literature consistently reports that particle numbers close to airports are significantly higher than locations distant and upwind of airports, and that the particle size distribution is different from traditional road traffic, with more extremely fine particles.<sup>53</sup> Similar findings have been published from European studies.<sup>54 55 56 57 58 59</sup> Results of a monitoring study of communities near Seattle-Tacoma International Airport also found higher levels of ultrafine PM near the airport, and an impacted area larger than at near-roadway sites.<sup>60</sup> The PM associated with aircraft landing activity was also smaller in size, with lower black carbon concentrations than near-roadway samples. As discussed above, PM<sub>2.5</sub> exposures are associated with a number of serious, adverse health effects. Further, the PM attributable to aircraft emissions has been associated with potential adverse health impacts.<sup>61 62</sup> For example, He et al.

<sup>53</sup> Stacey, B. 2019. Measurement of ultrafine particles at airports: A review. *Atmos. Environ.* 198: 463–477. <https://www.sciencedirect.com/science/article/pii/S1352231018307313>.

<sup>54</sup> Masiol M, Harrison RM. Quantification of air quality impacts of London Heathrow Airport (UK) from 2005 to 2012. *Atmos Environ* 2017;116:308–19. <https://doi.org/10.1016/j.atmosenv.2015.06.048>.

<sup>55</sup> Keuken, M.P., Moerman, M., Zandveld, P., Henzing, J.S., Hoek, G., 2015. Total and size-resolved particle number and black carbon concentrations in urban areas near Schiphol airport (the Netherlands). *Atmos. Environ.* 104: 132–142. <https://www.sciencedirect.com/science/article/pii/S1352231015000175?via%3Dihub>.

<sup>56</sup> Pirhadi, M., Mousavi, A., Sowlat, M.H., Janssen, N.A.H., Cassee, F.R., Sioutas, C., 2020. Relative contributions of a major international airport activities and other urban sources to the particle number concentrations (PNCs) at a nearby monitoring site. *Environ. Pollut.* 260: 114027. <https://www.sciencedirect.com/science/article/pii/S0269749119344987?via%3Dihub>.

<sup>57</sup> Stacey, B., Harrison, R.M., Pope, F., 2020. Evaluation of ultrafine particle concentrations and size distributions at London Heathrow Airport. *Atmos. Environ.*, 222: 117148. <https://www.sciencedirect.com/science/article/pii/S1352231019307873?via%3Dihub>.

<sup>58</sup> Ungeheuer, F., Pinxteren, D., Vogel, A. 2021. Identification and source attribution of organic compounds in ultrafine particles near Frankfurt International Airport. *Atmos. Chem. Phys.* 21: 3763–3775. <https://doi.org/10.5194/acp-21-3763-2021>.

<sup>59</sup> Zhang, X., Karl, M., Zhang, L., Wang, J., 2020. Influence of Aviation Emission on the Particle Number Concentration near Zurich Airport. *Environ. Sci. Technol.* 54: 14161–14171. <https://doi.org/10.1021/acs.est.0c02249>.

<sup>60</sup> University of Washington. 2019. Mobile Observations of Ultrafine Particles: The Mov-UP study report. <https://deohs.washington.edu/mov-up>.

<sup>61</sup> Habre, R., Zhou, H., Eckel, S., Enebish, T., Fruin, S., Bastain, T., Rappaport, E., Gilliland, F. 2018. Short-term effects of airport-associated ultrafine particle exposure on lung function and inflammation in adults with asthma. *Environment International* 118: 48–59. <https://doi.org/10.1016/j.envint.2018.05.031>.

<sup>62</sup> He, R.W., Shirmohammadi, F., Gerlofs-Nijland, M.E., Sioutas, C., & Cassee, F.R. 2018. Pro-

<sup>45</sup> U.S. Environmental Protection Agency (U.S. EPA). 2018. Integrated Science Assessment (ISA) for Oxides of Nitrogen, Oxides of Sulfur and Particulate Matter Ecological Criteria Second External Review Draft). EPA–600–R–18–097. Washington, DC. December. Available on the internet at <https://cfpub.epa.gov/ncea/isa/recordisplay.cfm?deid=340671>.

<sup>46</sup> Yim, S.H.L., Lee, G.L., Lee, I.H., Allrogen, F., Ashok, A., Caiazzo, F., Eatham, S.D., Malina, R., Barrett, S. R.H. 2015. Global, regional, and local health impacts of civil aviation emissions. *Environ. Res. Lett.* 10: 034001. <https://iopscience.iop.org/article/10.1088/1748-9326/10/3/034001>.

<sup>47</sup> Brunelle-Yeung, E., Masek, T., Rojo, J., Levy, J., Arunachalam, S., Miller, S., Barrett, S., Kuhn, S., Waitz, I. 2014. Assessing the impact of aviation environmental policies on public health. *Transport Policy* 34: 21–28. <https://www.sciencedirect.com/science/article/pii/S0967070X14000468?via%3Dihub>.

<sup>48</sup> Kim, B., Nakada, K., Wayson, R., Christie, S., Paling, C., Bennett, M., Raper, D., Raps, V., Levy, J., Roof, C. 2015. Understanding Airport Air Quality and Public Health Studies Related to Airports. Airport Cooperative Research Program, ACRP Report 135. <https://trid.trb.org/view/1364659>.

<sup>49</sup> Kim, B., Nakada, K., Wayson, R., Christie, S., Paling, C., Bennett, M., Raper, D., Raps, V., Levy, J., Roof, C. 2015. Understanding Airport Air Quality and Public Health Studies Related to Airports. Airport Cooperative Research Program, ACRP Report 135, p. 39. <https://trid.trb.org/view/1364659>.

<sup>50</sup> Wing, S.E., Larson, T.V., Hudda, N., Boonyarattaphan, S., Fruin, S., Ritz, B. 2020. Preterm birth among infants exposed to in utero ultrafine particles from aircraft emissions. *Environ. Health Perspect.* 128, <https://doi.org/10.1289/EHP5732>.

<sup>51</sup> Hudda, N., Simon, N.C., Zamore, W., Durant, J.L. 2018. Aviation-related impacts on ultrafine particle number concentrations outside and inside residences near an airport. *Environ. Sci. Technol.* 52: 1765–1772. <https://pubs.acs.org/doi/abs/10.1021/acs.est.7b05593>.

<sup>52</sup> Hudda, N., Simon, M.C., Zamore, W., Brugge, D., Durant, J.L. 2016. Aviation emissions impact ultrafine particle concentrations in the greater Boston area. *Environ. Sci. Technol.* 50: 8514–8521. <https://pubs.acs.org/doi/abs/10.1021/acs.est.6b01815>.

(2018) found that particle composition, size distribution and internalized amount of particles near airports all contributed to promotion of reactive organic species in bronchial epithelial cells.

Because of these potential impacts, a systematic literature review was recently conducted to identify peer-reviewed literature on air quality near commercial airports and assess the quality of the studies.<sup>63</sup> The systematic review identified seventy studies for evaluation. These studies consistently showed that particulate matter, in the form of ultrafine PM (UFP), is elevated in and around airports. Furthermore, many studies showed elevated levels of black carbon, criteria pollutants, and polycyclic aromatic hydrocarbons as well. Finally, the systematic review, while not focused on health effects, identified a limited number of references reporting adverse health effects impacts, including increased rates of premature death, pre-term births, decreased lung function, oxidative DNA damage and childhood leukemia. More research is needed linking particle size distributions to specific airport activities, and proximity to airports, characterizing relationships between different pollutants, evaluating long-term impacts, and improving our understanding of health effects.

A systematic review of health effects associated with exposure to jet engine emissions in the vicinity of airports was also recently published.<sup>64</sup> This study concluded that literature on health effects was sparse, but jet engine

inflammatory responses to PM(0.25) from airport and urban traffic emissions. *The Science of the total environment*, 640–641, 997–1000. <https://www.sciencedirect.com/science/article/pii/S0048969718320394?via%3Dihub>.

<sup>63</sup> Riley, K., Cook, R., Carr, E., Manning, B. 2021. A Systematic Review of The Impact of Commercial Aircraft Activity on Air Quality Near Airports. *City and Environment Interactions*, 100066. <https://doi.org/10.1016/j.cacint.2021.100066>.

<sup>64</sup> Bendtsen, K. M., Bengtsen, E., Saber, A., Vogel, U. 2021. A review of health effects associated with exposure to jet engine emissions in and around airports. *Environ. Health* 20:10. <https://doi.org/10.1186/s12940-020-00690-y>.

emissions have physicochemical properties similar to diesel exhaust particles, and that exposure to jet engine emissions is associated with similar adverse health effects as exposure to diesel exhaust particles and other traffic emissions. A 2010 systematic review by the Health Effects Institute (HEI) concluded that evidence was sufficient to support a causal relationship between exposure to traffic-related air pollution and exacerbation of asthma among children, and suggestive of a causal relationship for childhood asthma, non-asthma respiratory symptoms, impaired lung function and cardiovascular mortality.<sup>65</sup>

#### *E. Contribution of Aircraft Emissions to PM in Selected Areas*

This section provides background on the contribution of aircraft engine emissions to local PM concentrations. In some areas with large commercial airports, turbine engine aircraft can make a significant contribution to ambient PM<sub>2.5</sub>. To evaluate these potential impacts, we identified the 25 airports where commercial aircraft operations are the greatest, based on data for 2017 from the Federal Aviation Administration (FAA) Air Traffic Data System (ATADS).<sup>66</sup> These 25 commercial airports are located in 24 counties and 22 metropolitan statistical areas (MSAs). We compared the contributions of these airports to emissions at both the county and MSA levels. Comparisons at both scales provide a fuller picture of how airports are impacting local air quality. Figure III–1 depicts the contribution to county-level PM<sub>2.5</sub> direct emissions from all turbine aircraft in that county with rated output of greater than 26.7 kN. Emissions data were obtained from the EPA 2017 National Emissions Inventory

<sup>65</sup> Health Effects Institute. “Special Report 17: A Special Report of the Institute’s Panel on the Health Effects of Traffic-Related Air Pollution.” January, 2010. <https://www.healtheffects.org/publication/traffic-related-air-pollution-critical-review-literature-emissions-exposure-and-health>.

<sup>66</sup> <https://aspm.faa.gov/opsnet/sys/main.asp>.

(NEI).<sup>67</sup> The contributions of engines greater than 26.7 kN rated output to total turbine engine emissions at individual airports were estimated based on FAA data.<sup>68</sup> At the county level, contributions to total mobile source PM<sub>2.5</sub> emissions range from less than 1 to almost 14 percent. However, it should be noted that two airports cross county lines—Hartsfield-Jackson Atlanta International Airport (Clayton and Fulton counties) and O’Hare (Cook and DuPage counties). For those airports, percentages are calculated for the sum of the two counties. In addition, five of these counties are in nonattainment for either the PM<sub>2.5</sub> or PM<sub>10</sub> standard. When emissions from these airports are considered as part of the entire MSA, the contribution is much smaller. Figure III–2 depicts the contributions at the metropolitan statistical area (MSA) instead of the county level, and contributions across airports range from 0.4 to 3 percent. Details of this analysis are described in a memorandum to the docket.<sup>69</sup>

**BILLING CODE 6560–50–P**

<sup>67</sup> 2017 National Emissions Inventory: Aviation Component, Eastern Research Group, Inc., July 25, 2019, EPA Contract No. EP-C-17-011, Work Order No. 2–19. Available at <https://www.epa.gov/air-emissions-inventories/2017-national-emissions-inventory-nei-data> (last accessed on June 27, 2021). See section 3.2 for airports and aircraft related emissions in the Technical Supporting Document for the 2017 National Emissions Inventory, January 2021 Updated Release. Available at [https://www.epa.gov/sites/production/files/2021-02/documents/nei2017\\_tsd\\_full\\_jan2021.pdf](https://www.epa.gov/sites/production/files/2021-02/documents/nei2017_tsd_full_jan2021.pdf) (last accessed on June 27, 2021).

<sup>68</sup> These data were obtained using radar-informed data from the FAA Enhanced Traffic Management System (ETMS). The annual fuel burn and emissions inventories at selected top US airports were based on the 2015 FAA flight operations database. The fraction of total PM emissions from aircraft covered by the proposed PM standards is based on the ratio of total PM emissions from flights by engines with thrust rating >26.7 kN compared to PM emissions from the whole fleet at each airport.

<sup>69</sup> Cook, R. Memorandum to Docket EPA–HQ–OAR–2019–0660, July 28, 2021, “Estimation of 2017 Emissions Contributions of Turbine Aircraft >26.7 kN to NO<sub>x</sub> and PM<sub>2.5</sub> as a Percentage of All Mobile PM<sub>2.5</sub> for the Counties and MSAs in Which the Airport Resides, 25 Largest Carrier Operations.”

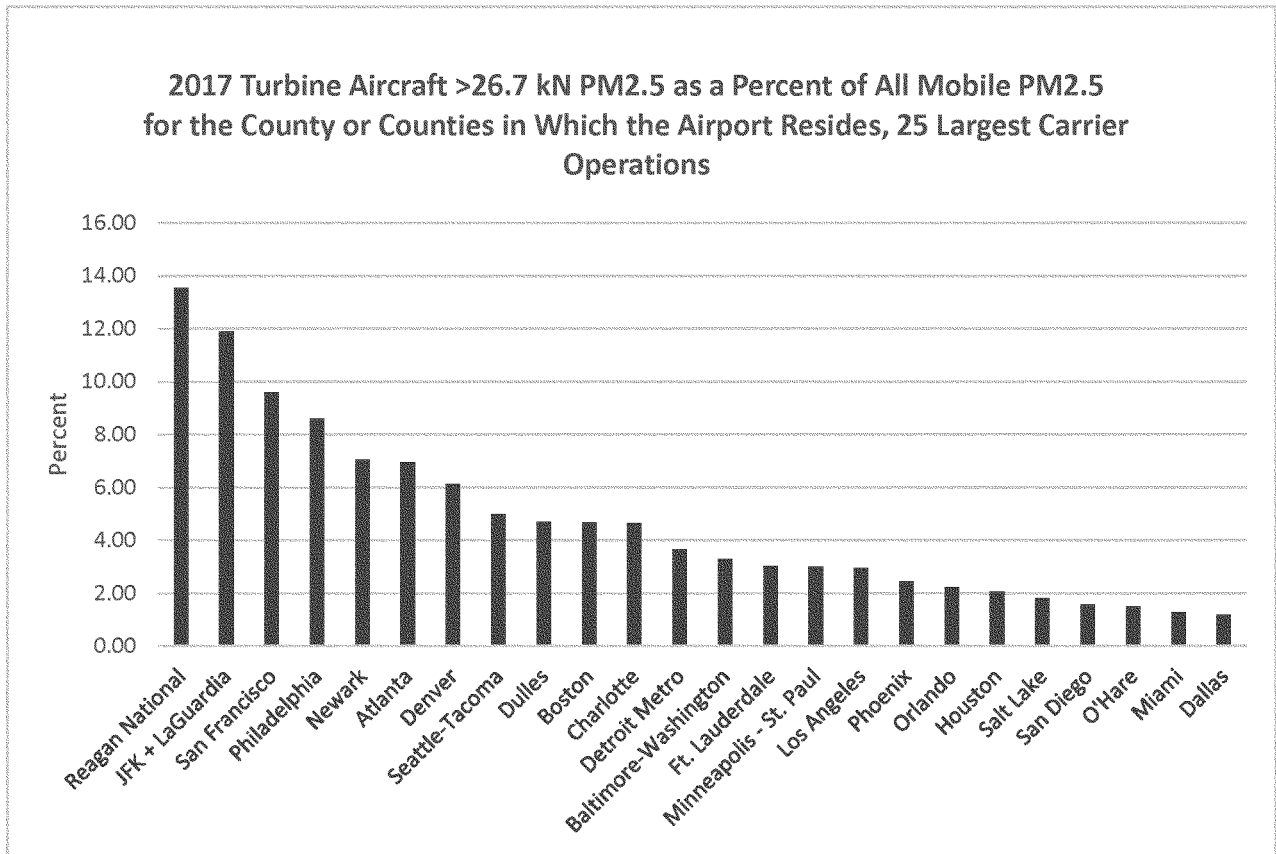

Figure III-1

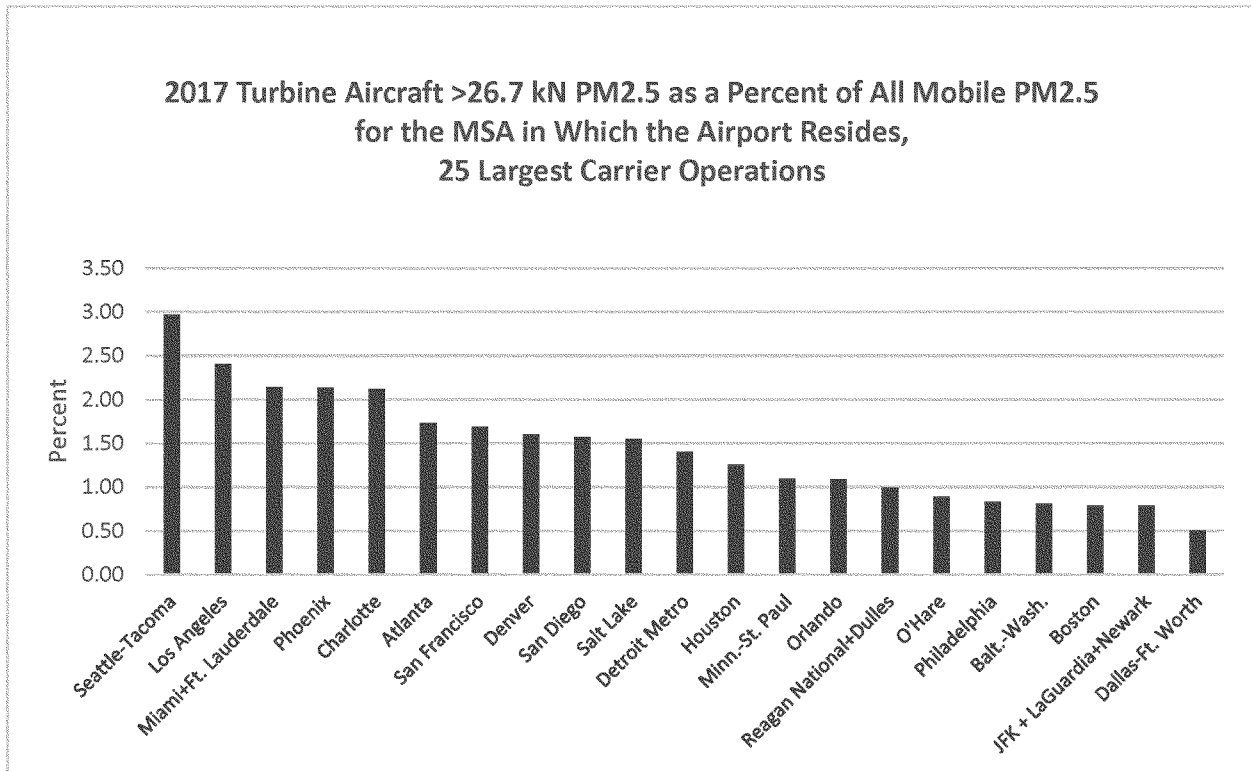

Figure III-2

BILLING CODE 6560-50-C

*F. Other Pollutants Emitted by Aircraft*

In addition to particulate matter, a number of other criteria pollutants are emitted by the aircraft which are the subject of this proposed rule. These pollutants, which are not covered by the rule, include nitrogen oxides (NO<sub>x</sub>), including nitrogen dioxide (NO<sub>2</sub>), volatile organic compounds (VOC), carbon monoxide (CO), and sulfur dioxide (SO<sub>2</sub>). Aircraft also contribute to ambient levels of hazardous air pollutants (HAP), compounds that are known or suspected human or animal carcinogens, or that have noncancer health effects. These compounds include, but are not limited to, benzene, 1,3-butadiene, formaldehyde, acetaldehyde, acrolein, polycyclic organic matter (POM), and certain metals. Some POM and HAP metals are components of PM<sub>2.5</sub> mass measured in turbine engine aircraft emissions.<sup>70</sup>

The term polycyclic organic matter (POM) defines a broad class of compounds that includes the polycyclic aromatic hydrocarbon compounds (PAHs). POM compounds are formed primarily from combustion and are present in the atmosphere in gas and particulate form. Metal compounds emitted from aircraft turbine engine combustion include chromium, manganese, and nickel. Several POM compounds, as well as hexavalent chromium, manganese compounds and nickel compounds are included in the National Air Toxics Assessment, based on potential carcinogenic risk.<sup>71</sup> In addition, as mentioned previously, deposition of metallic compounds can have ecological effects. Impacts of POM and metals are further discussed in the memorandum to the docket referenced above.

*G. Environmental Justice*

Executive Order 12898 (59 FR 7629, February 16, 1994) establishes federal executive policy on environmental justice. It directs federal agencies, to the greatest extent practicable and

permitted by law, to make achieving environmental justice part of their mission by identifying and addressing, as appropriate, disproportionately high and adverse human health or environmental effects of their programs, policies, and activities on minority populations and low-income populations in the United States. EPA defines environmental justice as the fair treatment and meaningful involvement of all people regardless of race, color, national origin, or income with respect to the development, implementation, and enforcement of environmental laws, regulations, and policies.<sup>72</sup>

Executive Order 14008 (86 FR 7619, February 1, 2021) also calls on federal agencies to make achieving environmental justice part of their missions “by developing programs, policies, and activities to address the disproportionately high and adverse human health, environmental, climate-related and other cumulative impacts on disadvantaged communities, as well as the accompanying economic challenges of such impacts.” It also declares a policy “to secure environmental justice and spur economic opportunity for disadvantaged communities that have been historically marginalized and overburdened by pollution and underinvestment in housing, transportation, water and wastewater infrastructure and health care.” Under Executive Order 13563, federal agencies may consider equity, human dignity, fairness, and distributional considerations, where appropriate and permitted by law.

<sup>72</sup> Fair treatment means that “no group of people should bear a disproportionate burden of environmental harms and risks, including those resulting from the negative environmental consequences of industrial, governmental and commercial operations or programs and policies.” Meaningful involvement occurs when “(1) potentially affected populations have an appropriate opportunity to participate in decisions about a proposed activity [e.g., rulemaking] that will affect their environment and/or health; (2) the public’s contribution can influence [the EPA’s rulemaking] decision; (3) the concerns of all participants involved will be considered in the decision-making process; and (4) [the EPA will] seek out and facilitate the involvement of those potentially affected” A potential EJ concern is defined as “the actual or potential lack of fair treatment or meaningful involvement of minority populations, low-income populations, tribes, and indigenous peoples in the development, implementation and enforcement of environmental laws, regulations and policies.” See “Guidance on Considering Environmental Justice During the Development of an Action.” Environmental Protection Agency, <https://www.epa.gov/environmentaljustice>.

EPA’s June 2016 “Technical Guidance for Assessing Environmental Justice in Regulatory Analysis” provides recommendations on conducting the highest quality analysis feasible, recognizing that data limitations, time and resource constraints, and analytic challenges will vary by media and regulatory context.<sup>73</sup>

When assessing the potential for disproportionately high and adverse health or environmental impacts of regulatory actions on minority populations, low-income populations, tribes, and/or indigenous peoples, the EPA strives to answer three broad questions: (1) Is there evidence of potential EJ concerns in the baseline (the state of the world absent the regulatory action)? Assessing the baseline will allow the EPA to determine whether pre-existing disparities are associated with the pollutant(s) under consideration (e.g., if the effects of the pollutant(s) are more concentrated in some population groups). (2) Is there evidence of potential EJ concerns for the regulatory option(s) under consideration? Specifically, how are the pollutant(s) and its effects distributed for the regulatory options under consideration? And, (3) do the regulatory option(s) under consideration exacerbate or mitigate EJ concerns relative to the baseline? It is not always possible to quantitatively assess these questions.

EPA’s 2016 Technical Guidance does not prescribe or recommend a specific approach or methodology for conducting an environmental justice analysis, though a key consideration is consistency with the assumptions underlying other parts of the regulatory analysis when evaluating the baseline and regulatory options. Where applicable and practicable, the Agency endeavors to conduct such an analysis. Going forward, EPA is committed to conducting environmental justice analysis for rulemakings based on a framework similar to what is outlined in EPA’s Technical Guidance, in addition to investigating ways to further weave environmental justice into the fabric of the rulemaking process.

<sup>73</sup> “Technical Guidance for Assessing Environmental Justice in Regulatory Analysis.” *Epa.gov*, Environmental Protection Agency, [https://www.epa.gov/sites/production/files/2016-06/documents/ejtg\\_5\\_6\\_16\\_v5.1.pdf](https://www.epa.gov/sites/production/files/2016-06/documents/ejtg_5_6_16_v5.1.pdf) (June 2016).

<sup>70</sup> Kinsey, J.S., Hays, M.D., Dong, Y., Williams, D.C. Logan, R. 2011. Chemical characterization of the fine particle emissions from commercial aircraft engines during the aircraft particle emissions experiment (APEX) 1–3. *Environ. Sci. Technol.* 45:3415–3421. <https://pubs.acs.org/doi/10.1021/es103880d>.

<sup>71</sup> <https://www.epa.gov/national-air-toxics-assessment>.

Numerous studies have found that environmental hazards such as air pollution are more prevalent in areas where people of color and low-income populations represent a higher fraction of the population compared with the general population, including near transportation sources.<sup>74 75 76 77 78</sup>

As described in Section III.D, concentrations of PM increase with proximity to an airport. Air pollution can disproportionately impact sensitive subpopulations near airports. Henry et al. (2019) studied impacts of several California airports on surrounding schools and found that over 65,000 students spend 1 to 6 hours a day during the academic year being exposed to airport pollution, and the percentage of impacted students was higher for those who were economically disadvantaged.<sup>79</sup> Rissman et al. (2013) studied PM<sub>2.5</sub> at the Hartsfield-Jackson Atlanta International Airport and found that the relationship between minority population percentages and aircraft-derived PM was found to grow stronger as concentrations increased.<sup>80</sup>

Additional studies have reported that many communities in close proximity to airports are disproportionately represented by minorities and low-income populations. McNair (2020) describes nineteen major airports that underwent capacity expansion projects between 2000 and 2010, thirteen of which met characteristics of race,

ethnicity, nationality and/or income that indicate a disproportionate impact on these residents.<sup>81</sup> Woodburn (2017) reports on changes in communities near airports from 1970–2010, finding suggestive evidence that at many hub airports over time, the presence of marginalized groups residing in close proximity to airports increased.<sup>82</sup>

Although not being conducted as part of this rulemaking, EPA is conducting a demographic analysis to explore whether populations living nearest the busiest runways show patterns of racial and socioeconomic disparity.<sup>83</sup> This will help characterize the state of environmental justice concerns and inform potential future actions. Finely resolved population data (*i.e.*, 30 square meters) will be paired with census block group demographic characteristics to evaluate if people of color, children, indigenous populations, and low-income populations are disproportionately living near airport runways compared to populations living further away. The results of this analysis could help inform additional policies to reduce pollution in communities living in close proximity to airports.

In summary, the proposed in-production standards for both PM mass and PM number are levels that all aircraft engines in production currently meet in order to align with ICAO's standards. Thus, the proposed standards are not expected to result in emission reductions, beyond the business-as-usual fleet turnover that would occur absent of the proposed standards. Therefore, we do not anticipate an improvement in air quality for those who live near airports where these aircraft operate.

#### IV. Details for the Proposed Rule

In considering what PM emissions standards for aircraft engines are appropriate to adopt under section 231 of the CAA, EPA, after consultation with FAA, took into consideration the importance of both controlling PM emissions and international harmonization of aviation requirements. In addition, the EPA gave significant weight to the U.S.'s treaty obligations

under the Chicago Convention in determining the need for and appropriate levels of PM standards. These considerations led the EPA to propose aircraft engine PM standards based on engine standards adopted by ICAO. When developing the PM standards, ICAO looked at three different methods of measuring the amount of PM emitted. The first is PM mass, or a measure of the total weight of the particles produced over the test cycle. This is how the EPA has historically set PM emissions standards for other sectors. Second, ICAO considered PM number, or the number of particles produced by the engine over the test cycle. These are two different methods of measuring the same pollutant, PM, but each provides distinct and valuable information. Third, ICAO developed PM mass concentration standards, as a replacement to the existing standards based on smoke number.

EPA's proposed action consists of three key parts: (1) A proposal for PM mass and number emissions standards for aircraft gas turbine engines, (2) a change in test procedure and form of the existing standards—from smoke number to PM mass concentration, and (3) new testing and measurement procedures for the PM emission standards and various updates to the existing gaseous exhaust emissions test procedures.

Sections IV.A through IV.C describe the proposed mass, number, and mass concentration standards for aircraft engines. Section IV.D describes the proposed test procedures and measurement procedures associated with the PM standards. Section IV.E presents information related to the proposed reporting requirements.

As discussed above in Section III.A, PM<sub>2.5</sub> consists of both volatile and nonvolatile PM, although only nonvolatile PM would be covered by the proposed standards. Only nonvolatile PM is present at the engine exit because the exhaust temperature is too high for volatile PM to form. The volatile PM (or secondary PM) is formed as the engine exhaust plume cools and mixes with the ambient air. The result of this is that the volatile PM is significantly influenced by the ambient conditions (or ambient air background composition). Because of this complexity, a test procedure to measure volatile PM has not yet been developed for aircraft engines. In order to directly measure nonvolatile PM, ICAO agreed to adopt a measurement procedure, as described below in Section IV.D, which is based on conditions that prevent the formation of volatile PM upstream of the measurement instruments. The intent of

<sup>74</sup> Rowangould, G.M. (2013) A census of the near-roadway population: Public health and environmental justice considerations. *Trans Res D* 25: 59–67. <https://dx.doi.org/10.1016/j.trd.2013.08.003>.

<sup>75</sup> Marshall, J.D., Swor, K.R., Nguyen, N.P. (2014) Prioritizing environmental justice and equality: Diesel emissions in Southern California. *Environ Sci Technol* 48: 4063–4068. <https://doi.org/10.1021/es405167f>.

<sup>76</sup> Marshall, J.D. (2000) Environmental inequality: Air pollution exposures in California's South Coast Air Basin. *Atmos Environ* 21: 5499–5503. <https://doi.org/10.1016/j.atmosenv.2008.02.005>.

<sup>77</sup> Tessum, C.W., Paoletta, D.A., Chambliss, SE, Apte, J.S., Hill, J.D., Marshall, J.D. (2021) PM<sub>2.5</sub> pollutants disproportionately and systemically affect people of color in the United States. *Science Advances* 7:eabf4491. <https://www.science.org/doi/10.1126/sciadv.abf4491>.

<sup>78</sup> Mohai, P., Pellow, D., Roberts Timmons, J. (2009) Environmental justice. *Annual Reviews* 34: 405–430. <https://doi.org/10.1146/annurev-environ-082508-094348>.

<sup>79</sup> Henry, R.C., Mohan, S., Yazdani, S. (2019) Estimating potential air quality impact of airports on children attending the surrounding schools. *Atmospheric Environment*, 212: 128–135. <https://www.sciencedirect.com/science/article/pii/S1352231019303516?via%3Dihub>.

<sup>80</sup> Rissman, J., Arunachalam, S., BenDor, T., West, J.J. (2013) Equity and health impacts of aircraft emissions at the Hartfield-Jackson Atlanta International Airport, *Landscape and Urban Planning* 120: 234–247. <https://www.sciencedirect.com/science/article/pii/S0169204613001382>.

<sup>81</sup> McNair, A. (2020) Investigation of environmental justice analysis in airport planning practice from 2000 to 2010. *Transp. Research Part D* 81:102286. <https://www.sciencedirect.com/science/article/pii/S1361920919311149?via%3Dihub>.

<sup>82</sup> Woodburn, A. (2017) Investigating neighborhood change in airport-adjacent communities in multi-airport regions from 1970 to 2010. *Journal of the Transportation Research Board*, 2626, 1–8.

<sup>83</sup> EPA anticipates that the results of the study will be released publicly in a separate document from the final rule.

this approach is to improve the consistency and repeatability of the nvPM measurement procedure.

Due to the international nature of the aviation industry, there is an advantage to working within ICAO, in order to secure the highest practicable degree of uniformity in international aviation regulations and standards. Uniformity in international aviation regulations and standards is a goal of the Chicago Convention, because it ensures that passengers and the public can expect similar levels of protection for safety and human health and the environment regardless of manufacturer, airline, or point of origin of a flight. Further, it helps prevent barriers in the global aviation market, benefiting both U.S. aircraft engine manufacturers and consumers.

When developing new emissions standards, ICAO/CAEP seeks to capture the technological advances made in the control of emissions through the adoption of anti-backsliding standards reflecting the current state of technology. The PM standards the EPA is proposing were developed using this approach. Thus, the adoption of these aircraft engine standards into U.S. law would simultaneously prevent aircraft engine PM levels from increasing beyond their current levels, align U.S. domestic standards with the ICAO standards for international harmonization, and help the U.S. meet its treaty obligations under the Chicago Convention.

These proposed standards would also allow U.S. manufacturers of covered aircraft engines to remain competitive in the global marketplace. The ICAO aircraft engine PM emission standards have been, or are being, adopted by other ICAO member states that certify aircraft engines. In the absence of U.S. standards implementing the ICAO aircraft engine PM emission standards, the U.S. would not be able to certify aircraft engines to the PM standards. In this case, U.S. civil aircraft engine manufacturers could be forced to seek PM emissions certification from an aviation certification authority of another country in order to market and operate their aircraft engines internationally. Foreign certification

authorities may not have the resources to certify aircraft engines from U.S. manufacturers in a timely manner, which could lead to delays in these engines being certified. Thus, U.S. manufacturers could be at a disadvantage if the U.S. does not adopt standards that are at least as stringent as the ICAO standards for PM emissions. The proposed action to adopt in the U.S. PM standards that match the ICAO standards would help ensure international consistency and acceptance of U.S. manufactured engines worldwide.

The EPA considered whether to propose standards more stringent than the ICAO standards. As noted above, the EPA considered both the need for emissions reductions and the international nature of the aircraft industry and air travel in evaluating whether to propose more stringent standards. These considerations have historically led the EPA to adopt international standards developed through ICAO. The EPA concluded that proposing to adopt the ICAO PM standards in place of more stringent standards is appropriate in part because international uniformity and regulatory certainty are important elements of these proposed standards. This is especially true for these proposed standards because they change our approach to regulating aircraft PM emissions from past smoke measurements to the measurement of nvPM mass and number for the first time. It is appropriate to gain experience from the implementation of these nvPM standards before considering whether to adopt more stringent nvPM mass and/or number standards, or whether another approach to PM regulation would better address the health risks of PM emissions from aircraft engines. Additionally, the U.S. Government played a significant role in the development of these proposed standards. The EPA believes that international cooperation on aircraft emissions brings substantial benefits overall to the United States. Having invested significant effort to develop these standards and obtain international consensus for ICAO to adopt these standards, a decision by the United States to deviate from them

might well undermine future efforts by the United States to seek international consensus on aircraft emissions standards. For these reasons, EPA placed significant weight on international regulatory uniformity and certainty and is proposing standards that match the standards which EPA worked to develop and adopt at ICAO, and is not proposing more stringent standards.

#### *A. PM Mass Standards for Aircraft Engines*

##### 1. Applicability of Standards

These proposed standards for PM mass, like the ICAO standards, would apply to all subsonic turbofan and turbojet engines of a type or model with a rated output (maximum thrust available for takeoff) greater than 26.7 kN whose date of manufacture is on or after January 1, 2023.<sup>84</sup> These proposed standards would not apply to engines manufactured prior to this applicability date.

The level of the proposed standard would vary based on when the initial type certification application is submitted.<sup>85</sup> Engines for which the type certificate application was first submitted on or after January 1, 2023 would be subject to the new type level in Section IV.A.2 below. These engines are new engines that have not been previously certificated.

Engines manufactured on or after January 1, 2023 would be subject to the in-production level, in Section IV.A.3 below.

<sup>84</sup> ICAO, 2017: *Aircraft Engine Emissions, International Standards and Recommended Practices, Environmental Protection, Annex 16, Volume II, Fourth Edition, July 2017, III-4-3 & III-4-4pp.* Available at [https://www.icao.int/publications/catalogue/cat\\_2021\\_en.pdf](https://www.icao.int/publications/catalogue/cat_2021_en.pdf) (last accessed November 15, 2021). The ICAO Annex 16 Volume II is found on page 17 of the ICAO Products & Services Catalog, English Edition of the 2021 catalog, and it is copyright protected; Order No. AN16-2. The ICAO Annex 16, Volume II, Fourth Edition, includes Amendment 10 of January 1, 2021. Amendment 10 is also found on page 17 of this ICAO catalog, and it is copyright protected; Order No. AN 16-2/E/12.

<sup>85</sup> In most cases, the engine manufacturer applies to FAA for the type certification; however, in some cases the applicant may be different than the manufacturer (e.g., designer).



2. New Type nvPM Mass Numerical Emission Limits for Aircraft Engines

Aircraft engines with a rated output (rO), maximum thrust available for take-

off, greater than 26.7 kN and whose initial type certification application is submitted to the FAA on or after January 1, 2023 shall not exceed the level, as defined by Equation IV-1. As

described in Section IV.D, the nvPM Mass limit is based on mg of PM divided by kN of thrust, as determined over the LTO cycle.

$$nvPM_{Mass} = \begin{cases} 1251.1 - 6.914 * rO, & 26.7 < rO \leq 150kN \\ 214.0, & rO > 150kN \end{cases}$$

Equation IV-1

3. In Production nvPM Mass Numerical Emission Limits for Aircraft Engines

Aircraft engines that are manufactured on or after January 1,

2023 shall not exceed the level, as defined by Equation IV-2.

$$nvPM_{Mass} = \begin{cases} 4646.9 - 21.497 * rO, & 26.7 < rO \leq 200kN \\ 347.5, & rO > 200kN \end{cases}$$

Equation IV-2

4. Graphical Representation of nvPM Mass Numerical Emission Limits

Figure IV-1 shows how the proposed nvPM mass emission limits compare to known in-production engines.

Data shown in this figure is from the ICAO Engine Emissions Databank (EEDB).<sup>86 87</sup>

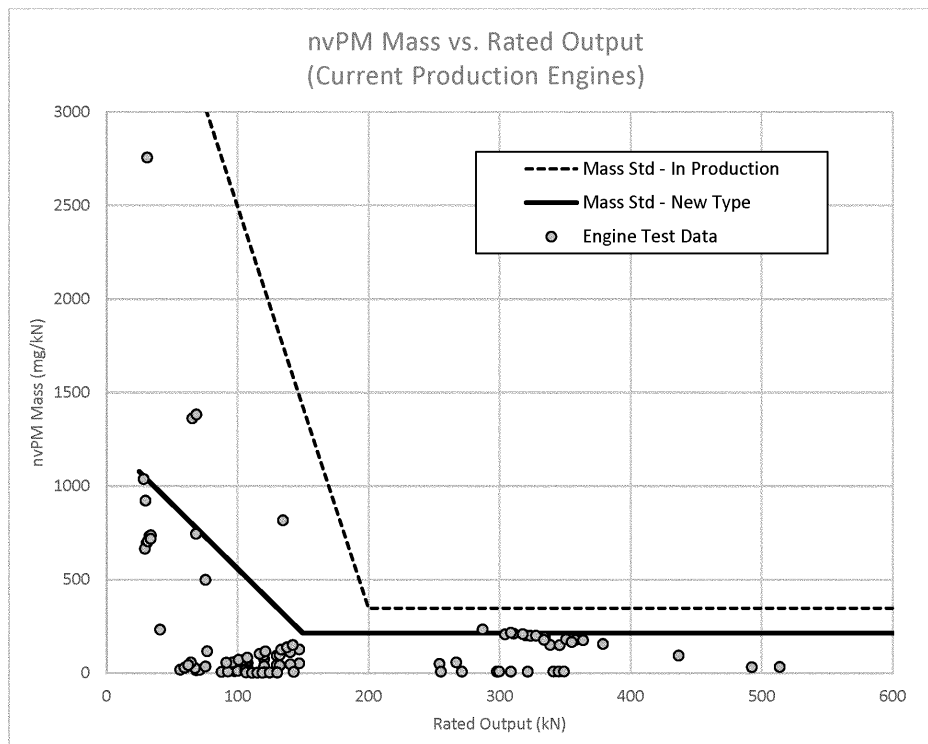

Figure IV-1 - nvPM mass standards compared to in-production engine LTO emission rates

B. PM Number Standards for Aircraft Engines

1. Applicability of Standards

These proposed standards for PM number, like the ICAO standards, would apply to all subsonic turbofan and

turbojet engines of a type or model with a rated output greater than 26.7 kN whose date of manufacture is on or after January 1, 2023.<sup>88</sup> These proposed standards would not apply to engines

manufactured prior to this applicability date.

The level of the proposed standard would vary based on when the initial type certification application is submitted. Engines for which the type

<sup>86</sup> ICAO Aircraft Engine Emissions Databank, July 20, 2021, "edb-emissions-databank v28C (web).xlsx", European Union Aviation Safety Agency (EASA), <https://www.easa.europa.eu/>

[domains/environment/icao-aircraft-engine-emissions-databank](https://www.easa.europa.eu/en/domains/environment/icao-aircraft-engine-emissions-databank).

<sup>87</sup> Note, EPA ICR number 2427.06 "Aircraft Engines—Supplemental information related to Exhaust Emissions" also collects aircraft nvPM

data. In the interest of using the most up to date information, the ICAO EDB was used because it has been updated more recently than EPA data. The EPA should be receiving new data from this ICR in Feb. 2022.

certificate application was first submitted on or after January 1, 2023 would be subject to the new type level in Section IV.B.2 below. These are new engines that have not been previously certificated.

Engines manufactured on or after January 1, 2023 would be subject to the in-production level, in IV.B.3 below.

2. New Type nvPM Number Numerical Emission Limits for Aircraft Engines

Aircraft engines with a rated output greater than 26.7 kN and whose initial

type certification application is submitted to the FAA on or after January 1, 2023 shall not exceed the level, as defined by Equation IV-3. As described in Section IV.D, the nvPM number limit is based on number of particles divided by kN of thrust, as determined over the LTO cycle.

$$nvPM_{num} = \begin{cases} 1.490 \cdot 10^{16} - 8.080 \cdot 10^{13} \cdot rO, & 26.7 < rO \leq 150kN \\ 2.780 \cdot 10^{15}, & rO > 150kN \end{cases}$$

Equation IV-3

3. In Production nvPM Number Numerical Emission Limits for Aircraft Engines

Aircraft engines that are manufactured on or after January 1,

2023 shall not exceed the level, as defined by Equation IV-4.

$$nvPM_{num} = \begin{cases} 2.669 \cdot 10^{16} - 1.126 \cdot 10^{14} \cdot rO, & 26.7 < rO \leq 200kN \\ 4.170 \cdot 10^{15}, & rO > 200kN \end{cases}$$

Equation IV-4

4. Graphical Representation of nvPM Number Numerical Emission Limits

Figure IV-2 shows how the proposed nvPM number emission limits compare to known in-production engines. Data

shown in this figure is from the ICA O Engine Emissions Databank (EEDB).<sup>89</sup>

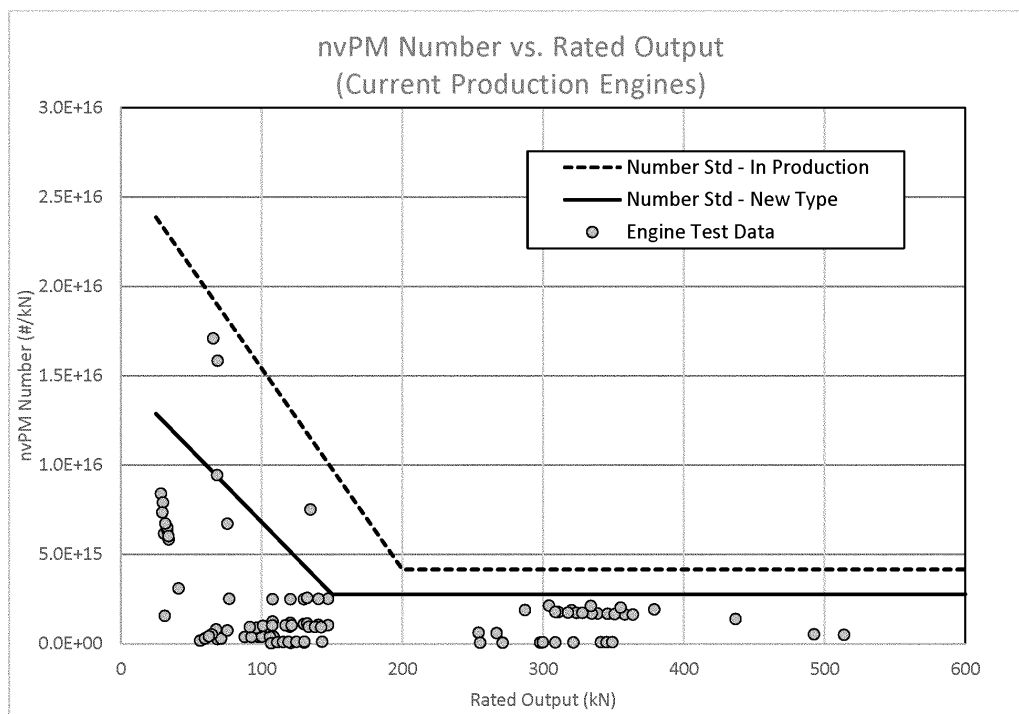

Figure IV-2 - nvPM number standards compared to in-production engine LTO emission rates

<sup>88</sup>ICAO, 2017: *Aircraft Engine Emissions, International Standards and Recommended Practices, Environmental Protection, Annex 16, Volume II, Fourth Edition, July 2017, III-4-4pp.* Available at [https://www.icao.int/publications/catalogue/cat\\_2021\\_en.pdf](https://www.icao.int/publications/catalogue/cat_2021_en.pdf) (last accessed November 15, 2021). The ICAO Annex 16 Volume II is found

on page 17 of the ICAO Products & Services Catalog, English Edition of the 2021 catalog, and it is copyright protected; Order No. AN16-2. The ICAO Annex 16, Volume II, Fourth Edition, includes Amendment 10 of January 1, 2021. Amendment 10 is also found on page 17 of this ICAO catalog, and it is copyright protected; Order No. AN 16-2/E/12.

<sup>89</sup>ICAO Aircraft Engine Emissions Databank, July 20, 2021, "edb-emissions-databank v28C (web).xlsx", European Union Aviation Safety Agency (EASA), <https://www.easa.europa.eu/domains/environment/icao-aircraft-engine-emissions/-databank> (last accessed November 15, 2021).

### C. PM Mass Concentration Standard for Aircraft Engines

The current smoke number-based standards were adopted to reduce the visible smoke emitted by aircraft engines. Smoke number is quantified by measuring the opacity of a filter after soot has been collected upon it during the test procedure. Another means of quantifying the smoke from an engine exhaust is through PM mass concentration (PM<sub>mc</sub>).

ICAO developed a PM mass concentration standard during the CAEP/10 cycle and adopted it in 2017. This PM mass concentration standard was developed to provide equivalent exhaust visibility control as the existing smoke number standard starting on January 1, 2020. With the EPA's involvement, the ICAO PM mass concentration limit line was developed using measured smoke number and PM mass concentration data from several engines to derive a smoke number-to-PM mass concentration correlation. This correlation was then used to transform the existing smoke number-based limit line into a generally equivalent PM mass concentration limit line, which was ultimately adopted by ICAO as the CAEP/10 PM mass concentration standard. The intention when the equivalent PM mass concentration standard was adopted was that equivalent visibility control would be

maintained and testing would coincide with the PM mass and PM number measurement, thus removing the need to separately test and measure smoke number.

While the ICAO PM mass concentration standard was intended to have equivalent visibility control as the existing SN standard, the method used to derive it was based on limited data and needed to be confirmed for regulatory purposes. Additional analysis was conducted during the CAEP/11 cycle to confirm this equivalence. The EPA followed this work as it progressed, provided input during the process, and ultimately concurred with the results.<sup>90</sup> The analysis, based on aerosol optical theory and visibility criterion, demonstrated with a high level of confidence that the ICAO PM mass concentration standard did indeed provide equivalent visibility control as the existing smoke number standard. This provided the justification for ICAO to agree to end applicability of the existing smoke number standard for engines subject to the PM mass concentration standard, effective January 1, 2023.

#### 1. PM Mass Concentration Standard

The EPA is proposing to adopt a PM mass concentration standard for all aircraft engines with rated output greater than 26.7 kN and manufactured

on or after January 1, 2023.<sup>91</sup> This proposed standard has the same form, test procedures, and stringency as the CAEP/10 PM mass concentration standard adopted by ICAO in 2017. However, the applicability date proposed here is different than that agreed to by ICAO. The proposed PM mass concentration standard is based on the maximum concentration of PM emitted by the engine at any thrust setting, measured in micrograms (µg) per meter cubed (m<sup>3</sup>). This is similar to the current smoke standard, which is also based on the measured maximum at any thrust setting. Section IV.D describes the measurement procedure. Like the LTO-based PM mass and PM number standards discussed above, this is based on the measurement of nvPM only, not total PM emissions.

To determine compliance with the proposed PM mass concentration standard, the maximum nvPM mass concentration [µg/m<sup>3</sup>] would be obtained from measurement at sufficient thrust settings such that the emission maximum can be determined. The maximum value would then be converted to a characteristic level in accordance with the procedures in ICAO Annex 16, Volume II, Appendix 6. The resultant characteristic level must not exceed the regulatory level determined from the following formula:

$$\text{nvPM mass concentration} = 10^3 + 2.9 \times 10^{-0.274}$$

## Equation IV-5

Engines certificated under the new PM mass concentration standard would not need to certify smoke number values and would not be subject to in-use smoke standards. It is important to note that other smoke number standards remain in effect for in-production aircraft turbofan and turbojet engines at or below 26.7 kN rated output and for

in-production turboprop engines. Also, the in-use smoke standards will continue to apply to some already manufactured aircraft engines that were certified to smoke number standards.

#### 2. Graphical Representation of nvPM Mass Concentration Numerical Emission Limit

Figure IV-3 shows how the proposed nvPM mass concentration emission limits compare to known in-production engines. Data shown in this figure is from the ICAO Engine Emissions Databank (EEDB).<sup>92</sup>

<sup>90</sup> ICAO, 2019: *Report of Eleventh Meeting, Montreal, 4–15 February 2019, Committee on Aviation Environmental Protection*, Document 10126, CAEP/11. It is found on page 26 of the English Edition of the ICAO Products & Services 2021 Catalog and is copyright protected; Order No. 10126. For purchase available at: <https://www.icao.int/publications/Pages/catalogue.aspx> (last accessed November 15, 2021). The analysis performed to confirm the equivalence of the PM mass concentration standard and the SN standard

is located in Appendix C (starting on page 3C–33) of this report.

<sup>91</sup> ICAO, 2017: *Aircraft Engine Emissions, International Standards and Recommended Practices, Environmental Protection, Annex 16, Volume II, Fourth Edition, July 2017, III-4-3*. Available at [https://www.icao.int/publications/catalogue/cat\\_2021\\_en.pdf](https://www.icao.int/publications/catalogue/cat_2021_en.pdf) (last accessed November 15, 2021). The ICAO Annex 16 Volume II is found on page 17 of the ICAO Products & Services Catalog, English Edition of the 2021 catalog, and it is

copyright protected; Order No. AN16–2. The ICAO Annex 16, Volume II, Fourth Edition, includes Amendment 10 of January 1, 2021. Amendment 10 is also found on page 17 of this ICAO catalog, and it is copyright protected; Order No. AN 16–2/E/12.

<sup>92</sup> ICAO Aircraft Engine Emissions Databank, July 20, 2021, “edb-emissions-databank v28C (web).xlsx”, European Union Aviation Safety Agency (EASA), <https://www.easa.europa.eu/domains/environment/icao-aircraft-engine-emissions-databank>.

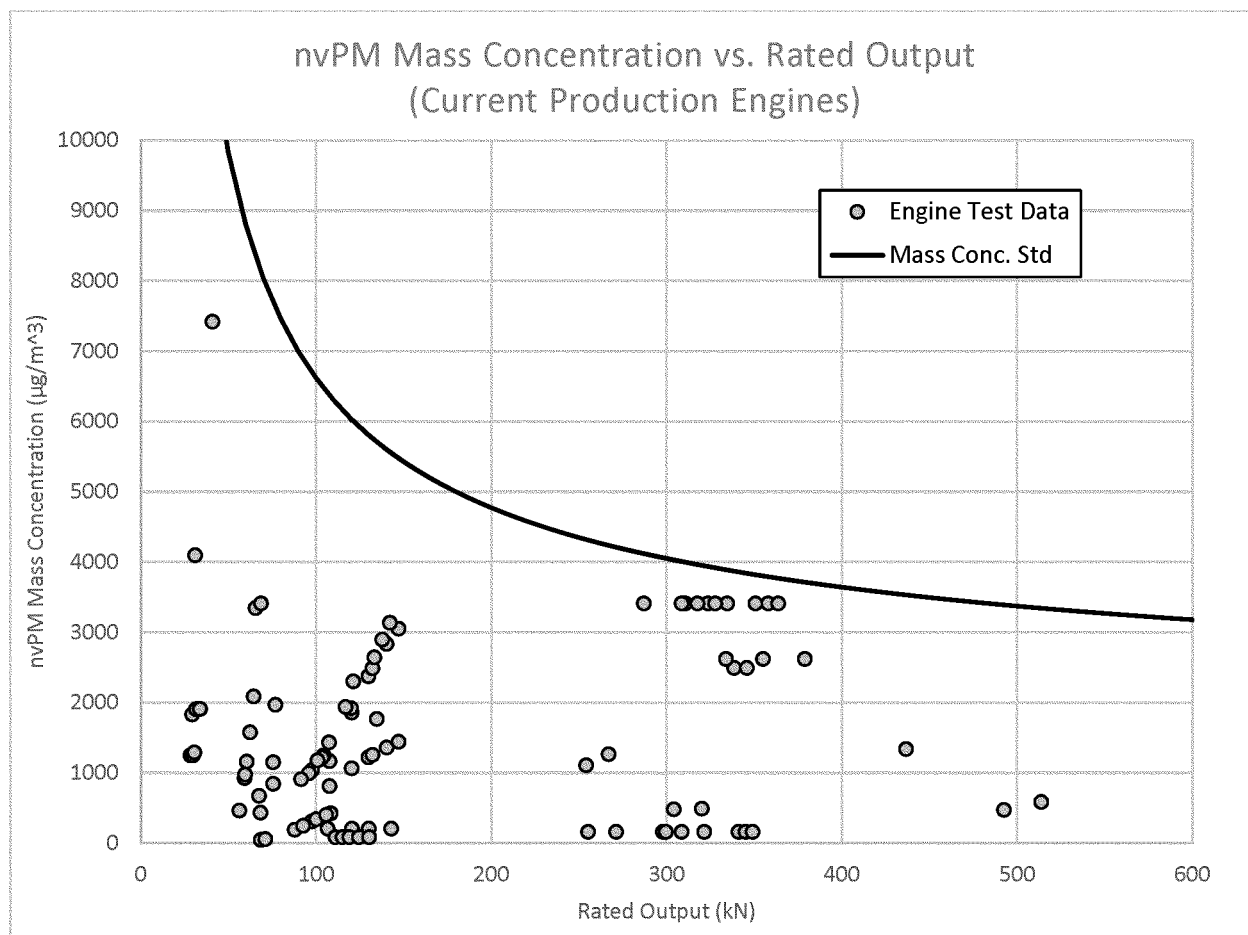

**Figure IV-3 - nvPM Mass Concentration Standard**

*D. Test and Measurement Procedures*

1. Aircraft Engine PM Emissions Metrics

When developing the PM standards, ICAO looked at three different methods of measuring the amount of PM emitted. The first is PM mass, or a measure of the total weight of the particles produced over the test cycle. This is how the EPA has historically measured PM emissions subject to standards for other sectors.

Second, ICAO considered PM number, or the number of particles produced by the engine over the test cycle. These are two different methods of measuring the same pollutant, PM, but each provides valuable information. Third, ICAO developed PM mass concentration standards, as an alternative to the existing visibility standards based on smoke.

The EPA proposes to incorporate by reference the metrics agreed at ICAO and incorporated into Annex 16 Volume II, to measure PM mass (Equation IV-6) and PM number (Equation IV-7). These metrics are based on a measurement of the nvPM emissions, as measured at the instrument, over the LTO cycle and is normalized by the rated output of the engine (rO).

$$nvPM_{mass} = \frac{\sum nvPM_{mass}}{rO} \left[ \frac{mg}{kN} \right]$$

**Equation IV-6**

$$nvPM_{num} = \frac{\sum nvPM_{number}}{rO} \left[ \frac{\#}{kN} \right]$$

**Equation IV-7**

The EPA proposes the PM mass concentration standard be based on the maximum mass concentration, in

micrograms per meter cubed, produced by the engine at any thrust setting.

Regulatory compliance with the emissions standards is based on the product of Equation IV-6 or Equation

IV-7 or mass concentration divided by a correction factor in Table IV-2, to obtain the characteristic level that is used to determine compliance with emissions standards (see IV.D.4 below).

2. Test Procedure

The emission test and measurement procedures adopted by ICAO were produced in conjunction with the Society of Automotive Engineers (SAE) E-31 Aircraft Exhaust Emissions Measurement Committee.<sup>93</sup> These procedures were developed in SAE E-31 in close consultation between government and industry, and subsequently they were adopted by ICAO and incorporated into ICAO Annex 16, Volume II.

These procedures build off the existing aircraft engine measurement system for gaseous pollutants. At least 3 engine tests need to be conducted to determine the emissions rates. These tests can be conducted on a single engine or multiple engines.<sup>94</sup> A representative sample of the engine exhaust is sampled at the engine exhaust exit. The exhaust then travels through a heated sample line where it is diluted and kept at a constant temperature prior to reaching the measurement instruments.

The methodology for measuring PM from aircraft engines differs from other test procedures for mobile source PM<sub>2.5</sub> standards in two ways. First, as discussed above, the procedure is designed to measure only the nonvolatile component of PM. The measurement of volatile PM is very

dependent on the environment where it is measured. The practical development of a standardized method of measuring volatile PM has proved challenging. Therefore, the development of a procedure for nvPM was prioritized and the result is proposed here today.

Second, the sample is measured continuously rather than being collected on a filter and measured after the test. This approach was taken primarily for the practical reasons that, due to high dilution rates leading to relatively low concentrations of PM in the sample, collecting enough particulate on a filter to analyze has the potential to take hours. Given the high fuel flow rates of these engines, such lengthy test modes would be very expensive. Additionally, because of the high volume of air required to run a jet engine and the extreme engine exhaust temperatures, it is not possible to collect the full exhaust stream in a controlled manner as is done for other mobile source PM<sub>2.5</sub> measurements.

Included in the proposed procedures, to be incorporated by reference, are measurement system specifications and requirements, instrument specifications and calibration requirements, fuel specifications, and corrections for fuel composition, dilution, and thermophoretic losses in the collection part of the sampling system.

To create a uniform sampling system design that works across gas turbine engine testing facilities, the test procedure calls for a 35-meter sample line. This results in a significant portion of the PM being lost in the sample lines,

on the order of 50 percent for PM mass and 90 percent for PM number. These particle losses in the sampling system are not corrected for in the regulatory compliance levels (standards).

Compliance with the standard is based on the measurement at the instruments rather than the exit plane of the engine (instruments are 35 meters from engine exit). This is due to the lack of robustness of the sampling system particle loss correction methodology and that a more stringent standard at the instrument will lead to a reduction in the nvPM emissions at the engine exit plane. A correction methodology has been developed to better estimate the actual PM emitted into the atmosphere. This correction is described below in Section V.A.2.

3. Test Duty Cycles

Mass and number PM emissions are proposed to be measured over the Landing and Take-Off (LTO) cycle shown in Table IV-1. This is the same duty cycle used today to measure gaseous emissions from aircraft engines and is intended to represent operations and flight under an altitude of 3,000 feet near an airport. Due to challenges in measuring at these exact conditions and atmospheric and fuel corrections that need to be applied after testing; it is not necessary to measure exactly at these points. Emissions rates for each mode can be calculated by testing the engine(s) over a sufficient range of thrust settings such that the emission rates at each condition in Table IV-1 can be determined.

TABLE IV-1—LANDING AND TAKE-OFF CYCLE THRUST SETTINGS AND TIME IN MODE <sup>95</sup>

LTO operating mode	Thrust setting Percent rO	Time in operating mode (minutes)
Take-off .....	100	0.7
Climb .....	85	2.2
Approach .....	30	4.0
Taxi/ground idle .....	7	26.0

The existing smoke number standard was adopted to reduce the visible smoke emitted from aircraft engines. Smoke number has been determined by

measuring the visibility or opacity of a filter after soot has been collected upon it during the test procedure. Another means of measuring this visibility is by

direct measurement of the particulate matter mass concentration. By measuring visibility based on mass concentration rather than smoke

<sup>93</sup> "E-31 Committee was formed to develop and maintain cognizance of standards for measurement of emissions from aircraft powerplants and to promote a rational and uniform approach to the measurement of emissions from aircraft engines and combustion systems to support the practical assessment of the industry. The E-31 Committee, in its operation uses an Executive Committee, Membership Panel, Subcommittees and working technical panels as required to achieve its objectives."

(See <https://www.sae.org/works/committeeHome.do?comID=TEAE31>, last accessed November 15, 2021).

<sup>94</sup> All three tests could be conducted on a single engine. Or two tests could be conducted on one engine and one test on a second engine. Or three separate engines could each be tested a single time.

<sup>95</sup> ICAO, 2017: *Aircraft Engine Emissions*, International Standards and Recommended Practices, Environmental Protection, Annex 16, Volume II, Fourth Edition, July 2017, III-4-2.

Available at [https://www.icao.int/publications/catalogue/cat\\_2021\\_en.pdf](https://www.icao.int/publications/catalogue/cat_2021_en.pdf) (last accessed November 15, 2021). The ICAO Annex 16 Volume II is found on page 17 of the ICAO Products & Services Catalog, English Edition of the 2021 catalog, and it is copyright protected; Order No. AN16-2. The ICAO Annex 16, Volume II, Fourth Edition, includes Amendment 10 of January 1, 2021. Amendment 10 is also found on page 17 of this ICAO catalog, and it is copyright protected; Order No. AN 16-2/E/12.

number, the number of tests needed can be reduced, and mass concentration data can be collected concurrently with other PM measurements. Like the existing smoke standard, the proposed PM mass concentration standard would be based on the maximum value at any thrust setting. The engine(s) would be tested over a sufficient range of thrust settings that the maximum can be determined. This maximum could be at any thrust setting and is not limited to the LTO thrust points.

We are proposing to incorporate by reference ICAO's International Standards and Recommended Practices for aircraft engine PM testing and

certification—ICAO Annex 16, Volume II.

4. Characteristic Level

Like existing gaseous standards, compliance with the PM standards is proposed to be determined based on the characteristic level of the engine. The characteristic level is a statistical method of accounting for engine-to-engine variation in the measurement based on the number of engines tested. A minimum of 3 engine emissions tests is needed to determine the engine type's emissions rates for compliance with emissions standards. The more engines that are used for testing increases the confidence that the emissions rate

measured is from a typical engine rather than a high or low engine.

Table IV–2 below is reproduced from Annex 16 Volume II Appendix 6 Table A6–1 and shows how these factors change based on the number of engines tested. As the number of engines tested increases, the factor also increases resulting in a smaller adjustment and reflecting the increased confidence that the emissions rate is reflective of the average engine off the production line. In this way, there is an incentive to test more engines to reduce the characteristic adjustment while also increasing confidence that the measured emissions rate is representative of the typical production engine.

TABLE IV–2—FACTORS TO DETERMINE CHARACTERISTIC VALUES <sup>96</sup>

Number of engines tested (i)	CO	HC	NO <sub>x</sub>	SN	nvPM mass concentration	nvPM LTO mass	nvPM LTO number
1	0.814 7	0.649 3	0.862 7	0.776 9	0.776 9	0.719 4	0.719 4
2	0.877 7	0.768 5	0.909 4	0.852 7	0.852 7	0.814 8	0.814 8
3	0.924 6	0.857 2	0.944 1	0.909 1	0.909 1	0.885 8	0.885 8
4	0.934 7	0.876 4	0.951 6	0.921 3	0.921 3	0.901 1	0.901 1
5	0.941 6	0.889 4	0.956 7	0.929 6	0.929 6	0.911 6	0.911 6
6	0.946 7	0.899 0	0.960 5	0.935 8	0.935 8	0.919 3	0.919 3
7	0.950 6	0.906 5	0.963 4	0.940 5	0.940 5	0.925 2	0.925 2
8	0.953 8	0.912 6	0.965 8	0.944 4	0.944 4	0.930 1	0.930 1
9	0.956 5	0.917 6	0.967 7	0.947 6	0.947 6	0.934 1	0.934 1
10	0.958 7	0.921 8	0.969 4	0.950 2	0.950 2	0.937 5	0.937 5
more than 10	1–0.13059/√i	1–0.24724/√i	1–0.09678/√i	1–0.15736/√i	1–0.15736/√i	1–0.19778/√i	1–0.19778/√i

For PM mass and PM number, the characteristic level would be based on the mean of all engines tested, and appropriately corrected, divided by the factor corresponding to the number of engine tests performed in Table IV–1. For PM mass concentration, the characteristic level would be based on the mean of the maximum values of all engines tested, and appropriately corrected, divided by the factor corresponding to the number of engine tests performed in Table IV–2.

For example, an engine type where three measurements were obtained from the same engine has an nvPM mass metric value of 100 mg/kN (mean metric

value of all engine tests). The nvPM LTO Mass factor (or nvPM mass characteristic factor) from Table IV–2 for three engines is 0.7194. The metric value, with applicable corrections applied, is then divided by the factor to obtain the characteristic level of the engine. Therefore, the resulting characteristic level for this engine type, to determine compliance with the nvPM mass standard is 139.005mg/kN. If instead three engines are each tested once, the characteristic factor would be 0.8858 and the nvPM mass characteristic level to determine compliance with the standard would be 112.892 mg/kN.

An engine type's characteristic level can also be further improved by testing additional engines. For example, if 10 separate engines were tested of the same type, the nvPM mass characteristic factor becomes 0.9375. The resulting characteristic level (assuming the average nvPM mass metric value remains 100 mg/kN) would be 106.667 mg/kN. This approach could be used if an engine exceeds the standard at the time it is initially tested or there is a desire to increase the margin to the standard for whatever reason. Table IV–3 shows these three different examples for nvPM LTO Mass.

TABLE IV–3—IMPACT OF THE NUMBER OF ENGINES TESTED ON RESULTING CHARACTERISTIC LEVEL

Number of engines tested	Number of tests per engine	Measured nvPM LTO mass (mg/kN)	Characteristic factor	Characteristic level (mg/kN)
1	3	100	0.7194	139.005
3	1	100	0.8858	112.892
10	1	100	0.9375	106.667

<sup>96</sup> ICAO, 2017: *Aircraft Engine Emissions, International Standards and Recommended Practices, Environmental Protection, Annex 16, Volume II, Fourth Edition, July 2017, App 6–2pp.* Available at <https://www.icao.int/publications/>

*catalogue/cat\_2021\_en.pdf* (last accessed November 15, 2021). The ICAO Annex 16 Volume II is found on page 17 of the ICAO Products & Services Catalog, English Edition of the 2021 catalog, and it is copyright protected; Order No. AN16–2. The ICAO

Annex 16, Volume II, Fourth Edition, includes Amendment 10 of January 1, 2021. Amendment 10 is also found on page 17 of this ICAO catalog, and it is copyright protected; Order No. AN 16–2/E/12.

We are proposing to incorporate by reference ICAO's International Standards and Recommended Practices for correcting engine measurements to characteristic value—ICAO Annex 16, Volume II, Appendix 6.

#### 5. Derivative Engines for Emissions Certification Purposes

Aircraft engines can remain in production for many years and be subject to numerous modifications during its production life. As part of the certification process for any change, the type certificate holder will need to show that the change does not impact the engine emissions. While some of these changes could impact engine emissions rates, many of them will not. To simplify the certification process and reduce burden on both type certificate holder and certification authorities, ICAO developed criteria to determine whether there has been an emissions change that requires new testing. Such criteria already exist for gaseous and smoke standards.

ICAO recommends that if the characteristic level for an engine was type certificated at a level that is at or above 80 percent of the PM mass, PM number, or PM mass concentration standard, the type certificate holder would be required to test the proposed derivative engine. If the engine is below 80 percent of the standard, engineering analysis can be used to determine new emission rates for the proposed derivative engines. Today, the EPA proposes to adopt these ICAO provisions.

Subsequently, ICAO evaluated the measurement uncertainty to develop criteria for determining if a proposed derivative engine's emissions are similar to the previously certificated engine's emissions, which are described below. Today, the EPA proposes to adopt these ICAO criteria.

For PM Mass measurements described above in Section IV.A, the following values would apply:

- 80 mg/kN if the characteristic level for  $\text{nvPM}_{\text{mass}}$  emissions is below 400 mg/kN.
- $\pm 20\%$  of the characteristic level if the characteristic level for  $\text{nvPM}_{\text{mass}}$  emissions is greater than or equal to 400 mg/kN.

For PM number measurements, described above in Section IV.B, the following values would apply:

- $4 \times 10^{14}$  particles/kN if the characteristic level for  $\text{nvPM}_{\text{num}}$  emissions is below  $2 \times 10^{15}$  particles/kN.
- $\pm 20\%$  of the characteristic level if the characteristic level for  $\text{nvPM}_{\text{num}}$

emissions is greater than or equal to  $2 \times 10^{15}$  particles/kN.

For PM mass concentration measurements described above in Section IV.C, the following values would apply:

- $\pm 200 \mu\text{g}/\text{m}^3$  if the characteristic level of maximum  $\text{nvPM}$  mass concentration is below  $1,000 \mu\text{g}/\text{m}^3$ .
- $\pm 20\%$  of the characteristic level if the characteristic level for maximum  $\text{nvPM}$  mass concentration is at or above  $1,000 \mu\text{g}/\text{m}^3$ .

If a type certificate holder can demonstrate that the engine's emissions are within these ranges, then new emissions rates would not need to be developed and the proposed derivative engine for emissions certification purposes could keep the existing emissions rates.

If the engine is not determined to be a derivative engine for emissions certification purposes, the certificate holder would need to certify the new emission rates for the engine.

#### E. Annual Reporting Requirement

In 2012, the EPA adopted an annual reporting requirement as part of a rulemaking to adopt updated aircraft engine  $\text{NO}_x$  standards.<sup>97</sup> This provision, adopted into 40 CFR 87.42, requires the manufacturers of covered engines to annually report data to the EPA which includes information on engine identification and characteristics, emissions data for all regulated pollutants, and production volumes. In 2018, the EPA issued an information collection request (ICR) which renewed the existing ICR and added PM information to the list of required data.<sup>98 99</sup> However, that 2018 ICR was not part of a rulemaking effort, and the new PM reporting requirements were not incorporated into the CFR at that time. Further, that 2018 ICR is currently being renewed (in an action separate from this proposal), and the EPA is proposing as part of that effort to add some additional data elements to the ICR (specifically, the emission indices for HC, CO, and  $\text{NO}_x$  at each mode of the LTO cycle).<sup>100 101</sup> The EPA is now proposing to formally incorporate all

<sup>97</sup> 77 FR 36342, June 18, 2012.

<sup>98</sup> 83 FR 44621, August 31, 2018.

<sup>99</sup> U.S. EPA, Aircraft Engines—*Supplemental Information Related to Exhaust Emissions (Renewal)*, OMB Control Number 2060–0680, ICR Reference Number 201809–2060–08, December 17, 2018. Available at [https://www.reginfo.gov/public/do/PRAViewICR?ref\\_nbr=201809-2060-008](https://www.reginfo.gov/public/do/PRAViewICR?ref_nbr=201809-2060-008), last accessed November 15, 2021.

<sup>100</sup> 86 FR 24614, May 7, 2021.

<sup>101</sup> Documentation and Public comments are available at: <https://www.regulations.gov/docket/EPA-HQ-OAR-2016-0546>, last accessed November 15, 2021.

aspects of that ICR, as proposed to be renewed, into the CFR in the proposed section 1031.150. It is important to note that the incorporation of the PM reporting requirements into the CFR would not create a new requirement for the manufacturers of aircraft engines. Rather, it would simply incorporate the existing reporting requirements (as proposed to be amended and renewed in a separate action) into the CFR for ease of use by having all the reporting requirements readily available in the CFR.

The EPA uses the collection of information to help conduct technology assessments, develop aircraft emission inventories (for current and future inventories), and inform our policy decisions—including future standard-setting actions. The information enables the EPA to further understand the characteristics of aircraft engines that are subject to emission standards—and engines proposed to be subject to the PM emission standards—and engines impact on emission inventories. In addition, the information helps the EPA set appropriate and achievable emission standards and related requirements for aircraft engines. Annually updated information helps in assessing technology trends and their impacts on national emissions inventories. Also, it assists the EPA to stay abreast of developments in the aircraft engine industry.

As discussed in Section VII, the EPA is proposing to migrate the existing 40 CFR part 87 regulatory text to a new 40 CFR part 1031. Part of that effort includes clarifying portions of the regulatory text for ease of use. In the existing 40 CFR 87.42(c)(6), the regulatory text does not specifically spell out some required data, but instead relies on incorporation by reference for a detailed listing of required items. 40 CFR 87.42(c)(6) references the data reporting provisions in ICAO's Annex 16, Volume II and lists the data from this Annex that is not required by the EPA's reporting requirement. For future ease of use, the EPA is proposing in the new 40 CFR 1031.150 to explicitly list all the required items rather than continuing the incorporation by reference approach in the existing reporting regulations. The reader is encouraged to consult the proposed 40 CFR 1031.150 text for a complete list of the required reporting items. However, as previously mentioned, this list contains all the currently required items as well as the HC, CO and  $\text{NO}_x$  emission indices as proposed in the separate ICR renewal action. Finally, the EPA is proposing to incorporate by reference Appendix 8 of

Annex 16, Volume II, which outlines procedures used to estimate measurement system losses, which are a required element of the proposed reporting provisions.

## V. Aggregate PM Inventory Impacts

The number of aircraft landings and takeoffs (LTO) affects PM emissions that contribute to the local air quality near airports. The LTO emissions are defined as emissions between ground level and an altitude of about 3,000 feet. They are composed of emissions during departure operations (from taxi-out movement from gate to runway, aircraft take-off run and climb-out to 3,000 feet), and during arrival operations (emissions from approach at or below 3,000 feet down to landing on the ground and taxi-in from runway to gate). These LTO emissions directly affect the ground level air quality at the vicinity of the airport since they are within the local mixing height. Depending on the meteorological conditions, the emissions will be mixed with ambient air down to ground level, dispersed, and transported to areas downwind from the airport with elevated concentration levels.<sup>102</sup>

As described earlier in Section III, aircraft PM emissions are composed of both volatile and nonvolatile PM components.<sup>103</sup> Starting from an air and

<sup>102</sup> A local air quality “. . . emissions inventory for aircraft focuses on the emission characteristics of this source relative to the vertical column of air that ultimately affects ground level pollutant concentrations. This portion of the atmosphere, which begins at the earth’s surface and is simulated in air quality models, is often referred to as the mixing zone” or mixing height. (See page 137.) The air in this mixing height is completely mixed and pollutants emitted anywhere within it will be carried down to ground level. (See page 143.) “The aircraft operations of interest within the [mixing height] are defined as the [LTO] cycle.” (See page 137.) The default mixing height in the U.S. is 3,000 feet. (EPA, 1992: Procedures for Emission Inventory Preparation—Volume IV: Mobile Sources, EPA420-R-92-009. Available at <https://nepis.epa.gov> (last accessed June 23, 2021).

<sup>103</sup> ICAO: 2019, ICAO Environmental Report, Available at [https://www.icao.int/environmental-protection/Documents/ICAO-ENV-Report/2019-F1-WEB%20\(1\).pdf](https://www.icao.int/environmental-protection/Documents/ICAO-ENV-Report/2019-F1-WEB%20(1).pdf) (last accessed on November 15, 2021, 2021). See pages 100 and 101 for a description of non-volatile PM and volatile PM.

“At the engine exhaust, particulate emissions mainly consist of ultrafine soot or black carbon emissions. Such particles are called “non-volatile” (nvPM). They are present at the high temperatures at the engine exhaust and they do not change in mass or number as they mix and dilute in the exhaust plume near the aircraft. The geometric mean diameter of these particles is much smaller than PM<sub>2.5</sub> (geometric mean diameter of 2.5 Microns) and ranges roughly from 15nm to 60nm (0.06 Microns). These are classified as ultrafine particles (UFP).” (See page 100.) “The new ICAO standard is a measure to control the ultrafine non-volatile particulate matter emissions emitted at the engine exit. . . .” (See page 101.)

“Additionally, gaseous emissions from engines can also condense to produce new particles (*i.e.*,

fuel mixture of 16.3 percent oxygen (O<sub>2</sub>), 75.2 percent nitrogen (N<sub>2</sub>), and 8.5 percent fuel, an aircraft engine yields combustion products of 27.6 percent water (H<sub>2</sub>O), 72 percent carbon dioxide (CO<sub>2</sub>), and ~0.02 percent sulfur oxide (SO<sub>x</sub>) with only 0.4 percent incomplete residual products which can be broken down to 84 percent nitrogen oxide (NO<sub>x</sub>), 11.8 percent carbon monoxide (CO), 4 percent unburned hydrocarbons (UHC), 0.1 percent PM and trace amount of other products.<sup>104</sup> Although the PM emissions are a small fraction of total engine exhaust, the composition and morphology of PM are complex and dynamic. While the proposed emission test procedures focus only on measuring nonvolatile PM (black carbon), our emissions inventory includes estimates for volatile PM (organic, lubrication oil residues and sulfuric acid) as well.

### A. Aircraft Engine PM Emissions for Modeling

To quantify the aircraft PM emissions for the purposes of developing or modeling an emissions inventory for this proposed rulemaking (for an inventory in the year 2017), we used an approximation method as described in Section V.A.1. For future emission inventories, this approximation method will not be needed for newly manufactured engines which will have measured PM emission indices (EIs) going forward. However, to accurately estimate the nvPM emissions at the engine exit for emission inventory purposes, loss correction factors for nvPM mass and nvPM number will need to be applied to the measured PM EIs due to particle losses in the nvPM sampling and measurement system. An improved approximation method as described in Section V.A.3 is expected to be used for modeling PM emissions of in-service engines that do not have measured PM data. For the final rulemaking, we expect to develop an updated PM emissions inventory based on available measured PM EIs data with

volatile particulate matter—vPM), or coat the emitted soot particles. Gaseous emissions species react chemically with ambient chemical constituents in the atmosphere to produce the so called secondary particulate matter. Volatile particulate matter is dependent on these gaseous precursor emissions. While these precursors are controlled by gaseous emission certification and the fuel composition (*e.g.*, sulfur content) for aircraft gas turbine engines, the volatile particulate matter is also dependent on the ambient air background composition.” (See pages 100 and 101.)

<sup>104</sup> European Monitoring and Evaluation Programme/European Environment Agency, Air Pollutant Emission Inventory Guidebook 2019; Available at <https://www.eea.europa.eu/themes/air/air-pollution-sources-1/emep-eea-air-/pollutant/-emission/-inventory-guidebook/emep> (last accessed June 26, 2021).

loss correction and the improved approximation method for engines without measured PM EIs.

### 1. Baseline PM Emission Indices

Measured PM data was not available to calculate the 2017 inventory. Thus, to calculate the baseline aircraft engine PM emissions, we used the FOA3 (First Order Approximation Version 3.0) method defined in the SAE Aerospace Information Reports, AIR5715.<sup>105</sup> For non-volatile PM mass, the FOA3 method is based on an empirical correlation of Smoke Number (SN) values and the non-volatile PM (nvPM) mass concentrations of aircraft engines. The nvPM mass concentration (g/m<sup>3</sup>) derived from SN can then be converted into an nvPM mass emission index (EI) in gram of nvPM per kg fuel using the method developed by Wayson et al,<sup>106</sup> based on a set of empirically determined Air Fuel Ratios (AFR) and engine volumetric flow rates at the four ICAO LTO thrust settings (see Table IV–1). Subsequently, the nvPM mass EI can be used to calculate the nvPM mass for the four LTO modes with engine fuel flow rate and time-in-mode information. As the name suggests, the FOA3 method is a rough estimate, and it is only for nvPM mass.

In addition, as described earlier (Sections III.A and IV), volatile PM and nvPM together make up total PM. The FOA3 method for volatile PM is based on the jet fuel organics<sup>107</sup> and sulfur content. Since the total PM inventory is the emissions inventory we are estimating for this proposed rulemaking, we are including the volatile PM emission estimates from the FOA3 method in our emission inventory.

### 2. Measured nvPM EIs for Inventory Modeling

The measurement and reporting of engine EIs will improve the development of future engine emission inventories. As mentioned in Section IV, the regulatory compliance level is based on the amount of particulate that is directly measured by the instruments. The test procedures specify a sampling line that can be up to 35 meters long. This length results in significant particle loss in the measurement system, on the

<sup>105</sup> SAE Aerospace Information Reports, AIR5715, Procedure for the Calculation of Aircraft Emissions, 2009, SAE International.

<sup>106</sup> Wayson RL, Fleming GG, Iovinelli R. Methodology to Estimate Particulate Matter Emissions from Certified Commercial Aircraft Engines. J Air Waste Management Assoc. 2009 Jan 1; 59(1).

<sup>107</sup> In this context, organics refers to hydrocarbons in the exhaust that coat on existing particles or condense to form new particles after the engine exit.



order of 50 percent for nvPM mass and 90 percent for nvPM number.<sup>108</sup> Further the particle loss is size dependent, and thus the losses will be dependent on the engine operating condition (e.g., idle vs take-off thrust), engine combustor design, and technology. To assess the emissions contribution of aircraft engines for inventory and modeling purposes, and subsequently for human health and environmental effects, it is necessary to know the emissions rate at the engine exit. Thus, the measured PM mass and PM number values must be corrected for system losses to determine the engine exit emissions rate.

The EPA led the effort within the SAE E-31 committee to develop the methodology to correct for system losses. This effort at E-31 resulted in the development and publication of AIR 6504 and ARP 6481 describing how to correct for system losses. ICAO has incorporated this same procedure into Annex 16 Vol. II Appendix 8.

The engine exit emissions rate, which is corrected for system losses, is specific to each measurement system and to each engine. The calculation is an iterative function based upon the measured nvPM mass and nvPM number values and the geometry of the measurement system. Manufacturers provide the corrected emissions values to the ICAO EDB and to the EPA.

When calculating emissions inventories, these corrected EIs will be used rather than the values used to show compliance with emission standards. These measured EIs are only for the nonvolatile component of PM, and an approximation method will still be required for quantifying the volatile PM inventory.

### 3. Improvements to Calculated EIs

The new version of the approximation method, known as FOA4, has been developed by CAEP to improve nvPM mass estimation and to extend the methodology to nvPM number based on the newly available PM measurement data.<sup>109</sup> Since PM mass and PM number are two different measurement metrics of the same pollutant, PM, they can be converted to each other if the size and density distribution of the pollutant can be characterized.<sup>110</sup> FOA4 was not used

in the baseline emission rates for this proposed rulemaking.

The calculation of volatile PM has not changed between FOA3 and FOA4 because no improved data or method has become available to inform improvements.

#### B. Baseline PM Emission Inventory

The baseline PM emissions inventory used for this proposed rule is from the aviation portion of EPA's 2017 National Emissions Inventory (NEI).<sup>111 112 113</sup> The NEI is compiled by EPA triennially based on comprehensive emissions data for criteria pollutants and hazardous air pollutants (HAPs) for mobile, point, and nonpoint sources. The mobile sources include aviation, marine, railroad, on-road vehicles, and nonroad engines. As described earlier in Section V.A, the aircraft emission estimates in this 2017 NEI (or the baseline PM emissions inventory) are based on the FOA instead of measured PM emissions data from aircraft engines proposed to be regulated by this rulemaking. For the final rulemaking, we anticipate potentially having an updated baseline PM emissions inventory based on measured data from numerous in-production engines (we would likely have PM data for nearly all in-production engines proposed to be regulated by this rulemaking).

The aviation emissions developed for the NEI include emissions associated with airport activities in commercial aircraft, air taxi aircraft,<sup>114</sup> general aviation aircraft, military aircraft, auxiliary power units, and ground support equipment. All emissions from aircraft with gas turbine engines greater than 26.7 kN rated output from the aircraft categories described earlier, except military aircraft, are used in the

nanometers for the four LTO modes (idle-taxi/approach/climbout/take-off) fits the data the best. Along with the assumptions of a log-normal size distribution, a geometric standard deviation of 1.8, and an effective density of 1,000 kg/m<sup>3</sup> for the exhaust plume at the engine exit plane, nvPM mass EI and nvPM number EI of LTO mode k can be converted to each other.

<sup>111</sup> 2017 National Emissions Inventory: Aviation Component, Eastern Research Group, Inc., July 25, 2019, EPA Contract No. EP-C-17-011, Work Order No. 2-19.

<sup>112</sup> See section 3.2 for airports and aircraft related emissions in the Technical Supporting Document for the 2017 National Emissions Inventory, January 2021 Updated Release; [https://www.epa.gov/sites/production/files/2021-02/documents/nei2017\\_tsd\\_full\\_jan2021.pdf](https://www.epa.gov/sites/production/files/2021-02/documents/nei2017_tsd_full_jan2021.pdf).

<sup>113</sup> <https://www.epa.gov/air-emissions-inventories/2017-national-emissions-inventory-wei-data>.

<sup>114</sup> Air taxis fly scheduled service carrying passengers and/or freight, but they usually are smaller aircraft and operate on a more limited basis compared to the commercial aircraft operated by airlines.

emissions inventory for this proposed rule (which is a subset of the aviation emissions inventory). To estimate emissions, 2017 activity data by states were compiled and supplemented with publicly available FAA data. The FAA activity data included 2017 T-100<sup>115</sup> dataset, 2014 Terminal Area Forecast (TAF)<sup>116</sup> data, 2014 Air Traffic Activity Data System (ATADS)<sup>117</sup> data, and 2014 Airport Master Record (form 5010)<sup>118</sup> data.<sup>119</sup> The NEI used the FAA's Aviation Environmental Design Tool (AEDT)<sup>120</sup> version 2d to estimate emissions for aircraft that were in the AEDT database. The NEI used a more general estimation methodology to account for emissions from aircraft types not available in AEDT by multiplying the reported activities by fleet-wide average emission factors of generic aircraft types (or by aircraft category—e.g., general aviation or air taxi).<sup>121</sup>

For aircraft PM contribution in 2017 to total mobile PM emissions in counties and MSA's for the top 25 airports (inventories for aircraft with engines >26.7 kN), see Figure III-1 and Figure III-2 in Section III.E.

As described earlier, the baseline emissions inventory is based on the total PM emissions, which includes both the nvPM and volatile PM components of total PM. The 2017 NEI does not provide inventories for these components of total PM. However, we estimate that nvPM is about 70 percent

<sup>115</sup> Title 14—Code of Federal Regulations—Part 241 Uniform System of Accounts and Reports for Large Certificated Air Carriers. T-100 Segment (All Carriers)—Published Online by Bureau of Transportation Statistics. [https://www.transtats.bts.gov/Fields.asp?Table\\_ID=293](https://www.transtats.bts.gov/Fields.asp?Table_ID=293). Accessed May 9, 2018.

<sup>116</sup> Federal Aviation Administration. Terminal Area Forecast (TAF). <https://aspm.faa.gov/main/taf.asp>. Accessed April 21, 2018.

<sup>117</sup> Federal Aviation Administration. ATADS: Airport Operations: Standard Report. <https://aspm.faa.gov/opsnet/sys/Airport.asp>. Accessed May 23, 2018.

<sup>118</sup> Federal Aviation Administration. 2009. Airport Master Record Form 5010. Published by GCR & Associates. <https://www.gcr1.com/5010WEB/>. Accessed May 21, 2009.

<sup>119</sup> The rationale for the use of multiple FAA activity databases is described in the 2017 NEI report (2017 National Emissions Inventory: Aviation Component, Eastern Research Group, Inc., July 25, 2019, EPA Contract No. EP-C-17-011, Work Order No. 2-19. See section 3.2 for airports and aircraft related emissions in the Technical Supporting Document for the 2017 National Emissions Inventory, January 2021 Updated Release; [https://www.epa.gov/sites/production/files/2021-02/documents/nei2017\\_tsd\\_full\\_jan2021.pdf](https://www.epa.gov/sites/production/files/2021-02/documents/nei2017_tsd_full_jan2021.pdf), last accessed June 26, 2021.)

<sup>120</sup> AEDT is a software system that models aircraft performance in space and time to estimate fuel consumption, emissions, noise, and air quality consequences. It is available at <https://aedt.faa.gov/> (last accessed on June 26, 2021).

<sup>121</sup> Ibid.

<sup>108</sup> Annex 16 Vol. II Appendix 8 Note 2.

<sup>109</sup> ICAO: Second edition, 2020: Doc 9889, Airport Air Quality Manual. Order Number 9889. See Attachment D to Appendix 1 of Chapter 3. Doc 9889 can be ordered from ICAO website: <https://store.icao.int/en/airport-air-quality-manual/-doc-9889> (last accessed June 28, 2021).

<sup>110</sup> Based on the newly available measurement data and inputs from technical experts in SAE E-31 Aircraft Exhaust Emissions Measurement Committee, CAEP has determined that a set of fixed geometric mean diameters (GMDs) of 20/20/40/40

(range 51 percent to 72 percent based on modal EIs of a sample engine) of the total PM.<sup>122</sup> We intend to improve this estimate for the final rulemaking. Applying the nvPM percentage (or fraction) to the total fleet-wide baseline PM inventory, or the 2017 NEI PM inventory for aircraft with gas turbine engines greater than 26.7 kN, would better enable us to estimate the nvPM portion of the aircraft contribution to total mobile PM accordingly.

### C. Projected Reductions in PM Emissions

Due to the technology-following nature of the PM standards, the proposed in-production and new type standards would not result in emission reductions below current levels of engine emissions. The proposed in-production standards for both PM mass and PM number, which would be set at levels where all in-production engines meet the standards, would not affect any in-production engines as shown in Figure IV–1 and Figure IV–2. Thus, the proposed standards are not expected to produce any emission reductions, beyond the business-as-usual fleet turn over that would occur absent of the proposed standards. The EPA projects that all future new type engines would meet the proposed new type standards. There are a few in-production engines that do not meet the proposed new type standards, but since in-production engines would not be subject to these new type standards, engine manufacturers would not be required to make any improvements to these engines to meet the standards. Therefore, there would be no emission reductions from the proposed new type standards.

Most of the in-production engines that do not meet the proposed new type standards are older engines that already have replacement in-production engines that would meet the proposed new type standards. There is only one newer in-production engine (an engine that recently started being manufactured) that would not meet the proposed new type standards and does not currently have a replacement in-production engine. Market forces might drive the manufacturer of this in-production engine to make some improvements to meet the proposed new type standards, but even in this scenario, this manufacturer would still have the option to retest the engine and/or make

minor adjustments or design modifications to improve the test result. The other option for this manufacturer would be to bring forward its next generation new type engine to the market a few years earlier than currently planned.<sup>123 124</sup> Since the new type standards would not apply to the in-production engines, this manufacturer could continue producing and selling its one in-production engine that does not meet the proposed new type standards. Further details on market forces are provided later in Section VI.A. In conclusion, when considering the proposed new type standards in the context of the in-production engines that already have a replacement engine or the one in-production engine that does not, there would be no emission reductions from the proposed new type standards.

## VI. Technological Feasibility and Economic Impacts

As described earlier, we are proposing PM mass concentration, PM mass, and PM number standards that match ICAO's standards. As discussed previously in Section V.C, for in-production aircraft engines, the 2017 ICAO PM maximum mass concentration standard and the 2020 ICAO PM mass and number standards are set at emission levels where all in-production engines meet these standards. Thus, there would not be costs or emission reductions associated with the proposed standards for in-production engines. For new type engines, the 2020 ICAO PM mass and number standards are set at more stringent emission levels compared to the PM mass and number standards for in-production engines, but nearly all in-production engines meet these new type standards. In addition, in-production engines would not be required to meet these new type standards. Only new type engines would need to comply with the new type standards. The EPA projects that all new type engines entering into service into the future will meet these PM mass and number standards. Thus, EPA expects that there would not be costs and emission reductions from the proposed standards for new type engines. In addition, following the final rulemaking for the PM standards, the FAA would issue a rulemaking to enforce compliance to these standards, and any anticipated certification costs

for the PM standards would be accounted for in the FAA rulemaking.

### A. Market Considerations

Aircraft and aircraft engines are sold around the world, and international aircraft emission standards help ensure the worldwide acceptability of these products. Aircraft and aircraft engine manufacturers make business decisions and respond to the international market by designing and building products that conform to ICAO's international standards. However, ICAO's standards need to be implemented domestically for products to prove such conformity. Domestic action through EPA rulemaking and subsequent FAA rulemaking enables U.S. manufacturers to obtain internationally recognized U.S. certification, which for the proposed PM standards would ensure type certification consistent with the requirements of the international PM emission standards. This is important, as compliance with the international standards (via U.S. type certification) is a critical consideration in aircraft manufacturer and airlines' purchasing decisions. By implementing the requirements in the United States that align with ICAO standards, any question regarding the compliance of aircraft engines certificated in the United States would be removed. The proposed rule would facilitate the acceptance of U.S. aircraft engines by member States, aircraft manufacturers, and airlines around the world. Conversely, without this domestic action, U.S. aircraft engine manufacturers would be at a competitive disadvantage compared with their international competitors.

In considering the aviation market, it is important to understand that the international PM emission standards were predicated on demonstrating ICAO's concept of technological feasibility; *i.e.*, that manufacturers have already developed or are developing improved technology that meets the ICAO PM standards, and that the new technology will be integrated in aircraft engines throughout the fleet in the time frame provided before the standards' effective date. Therefore, the EPA projects that these proposed standards would impose no additional burden on manufacturers.

### B. Conceptual Framework for Technology

The long-established ICAO/CAEP terms of reference were taken into account when deciding the international PM standards, principal among these being technical feasibility. For the ICAO PM standard setting, technical feasibility refers to refers to any

<sup>122</sup> ICAO: Second edition, 2020: Doc 9889, Airport Air Quality Manual. Order Number 9889. See Attachment D to Appendix 1 of Chapter 3. Doc 9889 can be ordered from ICAO website: <https://store.icao.int/en/airport-air-quality-manual/doc-9889> (last accessed June 28, 2021).

<sup>123</sup> <https://www.rolls-royce.com/products-and-services/civil-aerospace/future-products.aspx#/>; last accessed on June 26, 2021.

<sup>124</sup> <https://aviationweek.com/mro/rolls-royce-considers-ultrafan-development-pause/>; last accessed on June 26, 2021.

technology demonstrated to be safe and airworthy proven to Technical Readiness Level <sup>125</sup> (TRL) 8 and available for application over a sufficient range of newly certificated aircraft.<sup>126</sup> This means that the analysis that informed the international standard considered the emissions performance of aircraft engines assumed to be in-production on the implementation date for the PM mass and number standards, January 1, 2023.<sup>127</sup> The analysis included the current in-production fleet and engines scheduled for entry into the fleet by this date. (ICAO/CAEP's analysis was completed in 2018 and considered at the February 2019 ICAO/CAEP meeting.)

### C. Technological Feasibility

The EPA and FAA participated in the ICAO analysis that informed the adoption of the international aircraft engine PM emission standards. A summary of that analysis was published in the report of ICAO/CAEP's eleventh meeting (CAEP/11),<sup>128</sup> which occurred in February 2019. However, due to the commercial sensitivity of much of the data used in the ICAO analysis, the publicly available, published version of the ICAO report of the CAEP/11 meeting only provides limited supporting data for the ICAO analysis. Separately from this ICAO analysis and the CAEP/11 meeting report, information on technology for the control of aircraft engine PM emissions is provided in an Independent Expert Review document

<sup>125</sup> TRL is a measure of Technology Readiness Level. CAEP has defined TRL8 as the "actual system completed and 'flight qualified' through test and demonstration." TRL is a scale from 1 to 9, TRL1 is the conceptual principle, and TRL9 is the "actual system 'flight proven' on operational flight." The TRL scale was originally developed by NASA. ICF International, *CO<sub>2</sub> Analysis of CO<sub>2</sub>-Reducing Technologies for Aircraft*, Final Report, EPA Contract Number EP-C-12-011, see page 40, March 17, 2015.

<sup>126</sup> ICAO, 2019: *Report of the Eleventh Meeting*, Montreal, 4–15 February 2019, Committee on Aviation Environmental Protection, Document 10126, CAEP11. It is found on page 26 of the English Edition of the ICAO Products & Services 2021 Catalog and is copyright protected; Order No. 10126. For purchase and available at: [https://www.icao.int/publications/catalogue/cat\\_2021\\_en.pdf](https://www.icao.int/publications/catalogue/cat_2021_en.pdf) (last accessed November 15, 2021). The statement on technological feasibility is located in Appendix C of Agenda Item 3 of this report (see page 3C-4, paragraph 2.2).

<sup>127</sup> ICAO, 2019: *Report of the Eleventh Meeting*, Montreal, 4–15 February 2019, Committee on Aviation Environmental Protection, Document 10126, CAEP11. It is found on page 26 of the English Edition of the ICAO Products & Services 2021 Catalog and is copyright protected; Order No. 10126. For purchase and available at: [https://www.icao.int/publications/catalogue/cat\\_2021\\_en.pdf](https://www.icao.int/publications/catalogue/cat_2021_en.pdf) (last accessed November 15, 2021). The summary of technological feasibility and cost information is located in Appendix C to the report on Agenda Item 3 (starting on page 3C-1).

<sup>128</sup> *Ibid.*

on technology goals for engines and aircraft, which was published in 2019.<sup>129</sup> Although this ICAO document is primarily used for setting goals, and is not directly related to ICAO's adoption of the PM emission standards, information from the Independent Expert Review is helpful in understanding the state of aircraft engine technology.

The 2019 ICAO Independent Expert Review document indicates that new technologies aimed at reducing aircraft engine NO<sub>x</sub> also resulted in an order of magnitude reduction in nvPM mass and nvPM number in comparison to most in-service engines.<sup>130</sup> (As described earlier in Section IV.D.1, only nvPM emissions would be measured in the proposed test procedure for the proposed standards.) Specifically, the current lean-burn engines and some advanced Rich-Quench-Lean (RQL) engines <sup>131</sup> developed for the purpose of achieving low NO<sub>x</sub> emissions coincidentally provide order of magnitude reductions in nvPM emissions in comparison to existing RQL engines. However, achieving these levels of nvPM emissions will be more difficult for

<sup>129</sup> ICAO, 2019: *Independent Expert Integrated Technology Goals Assessment and Review for Engines and Aircraft*, Document 10127. It is found on page 32 of the English Edition of the ICAO Products & Services 2021 Catalog and is copyright protected; Order No. 10127. For purchase and available at: [https://www.icao.int/publications/catalogue/cat\\_2021\\_en.pdf](https://www.icao.int/publications/catalogue/cat_2021_en.pdf) (last accessed November 15, 2021).

<sup>130</sup> *Ibid.* See page 8 of this document.

<sup>131</sup> For lean-burn engines, ". . . enough air is introduced with the fuel from the injector so that it is never overall rich. In aviation combustors, the fuel is not premixed and pre-vaporized and in the microscopic region around each droplet, the mixture can be close to stoichiometric. However, the mixture remains lean throughout the combustor and temperature does not approach the stoichiometric value. . . . In a lean-burn combustor, the peak temperatures are not as high, so NO<sub>x</sub> is low." (See pages 47 and 48.) From previous generation rich-burn to lean-burn technology, an order of magnitude improvement in nvPM mass and nvPM number is likely for the LTO cycle. (See pages 57 and 58.)

For Rich-Quench-Lean (RQL) engines, ". . . the fuel first burns rich so there is little oxygen free to form NO<sub>x</sub>. Dilution air is introduced to take the mixture as quickly as possible through stoichiometric region (when it briefly gets very hot) to a cooler, lean state." (See page 47.) Potentially, an order of magnitude improvement in nvPM mass and nvPM number could be achieved for the LTO cycle from previous generation rich-burn to advanced rich-burn combustor technology. (See pages 57 and 58.)

ICAO, 2019: *Independent Expert Integrated Technology Goals Assessment and Review for Engines and Aircraft*, Document 10127. It is found on page 32 of the English Edition of the ICAO Products & Services 2021 Catalog and is copyright protected; Order No. 10127. For purchase and available at: [https://www.icao.int/publications/catalogue/cat\\_2021\\_en.pdf](https://www.icao.int/publications/catalogue/cat_2021_en.pdf) (last accessed November 15, 2021). See pages, 47, 48, 57, and 58 of this document.

physically smaller-sized engines due to technical constraints.<sup>132</sup> In addition, some previous generation engines that are in production meet the proposed new type standards, which match the ICAO standards, with considerable margin. When considering the nvPM emission levels for current in-production engines and those engines expected to be in production by the effective date of the ICAO standard, January 1, 2023, the lean-burn, advanced RQL, and some previous generation technologies (with relatively low levels of nvPM emissions) of many of the engines demonstrate that the proposed standards, which match ICAO standards, are technologically feasible.

### D. Costs Associated With the Proposed Rule

EPA does not anticipate new technology costs due to the proposed rule. Nevertheless, it is informative to describe the elements of cost analysis for technology improvements, such as non-recurring costs (NRC), certification costs, and recurring costs. As described in the summary of the ICAO analysis for the PM emission standards,<sup>133</sup> generally, CAEP considered certain factors as pertinent to the non-recurring cost estimates of a technology level for engine changes for PM mass and number. The first technology level was regarded as a minor change, and it could include minor improvements, and additional testing and re-certification of emissions. The PM mass and number

<sup>132</sup> For example, the relatively small combustor space and section height of these engines creates constraints on the use of low NO<sub>x</sub> combustor concepts, which inherently require the availability of greater flow path cross-sectional area than conventional combustors. Also, fuel-staged combustors need more fuel injectors, and this need is not compatible with the relatively smaller total fuel flows of lower thrust engines. (Reductions in fuel flow per nozzle are difficult to attain without having clogging problems due to the small sizes of the fuel metering ports.) In addition, lower thrust engine combustors have an inherently greater liner surface-to combustion volume ratio, and this requires increased wall cooling air flow. Thus, less air will be available to obtain acceptable turbine inlet temperature distribution and for emissions control. U.S. EPA, 2012: *Control of Air Pollution from Aircraft and Aircraft Engines; Emission Standards and Test Procedures; Final Rule*, 77 FR 36342, June 18, 2012. (See page 36353.)

<sup>133</sup> ICAO, 2019: *Report of the Eleventh Meeting*, Montreal, 4–15 February 2019, Committee on Aviation Environmental Protection, Document 10126, CAEP11. It is found on page 26 of the English Edition of the ICAO Products & Services 2021 Catalog and is copyright protected; Order No. 10126. For purchase and available at: [https://www.icao.int/publications/catalogue/cat\\_2021\\_en.pdf](https://www.icao.int/publications/catalogue/cat_2021_en.pdf) (last accessed November 15, 2021). See pages 3C-17 to 3C-19 in Appendix C to the report on Agenda Item 3 (starting on page 3C-1).

U.S. EPA, 2012: *Control of Air Pollution from Aircraft and Aircraft Engines; Emission Standards and Test Procedures; Final Rule*, 77 FR 36342, June 18, 2012. (See pages 36375 and 36376.)

emission reductions for the first technology level would be from 1 to 10 percent, and the estimated associated costs would be \$15 million. The second technology level was considered a scaled proven technology. At this level an engine manufacturer applies its best-proven, combustion technology that was already been certificated in at least one other engine type to another engine type. This second technology level would include substantial modeling, design, combustion rig testing, modification and testing of development engines, and flight-testing. The PM mass and number emission reductions for the second technology level would be a minimum of 10 percent, and the estimated associated costs would be \$150 million and \$250 million, respectively for PM mass and number. The third technology level was regarded as new technology or current industry best practice, and it was considered where a manufacturer has no proven technology that can be scaled to provide a solution and some technology acquisition activity is required. (One or more manufacturers have demonstrated the necessary technology, while the remaining manufacturers would need to acquire the technology to catch up.) The PM mass and number emission reductions for the third technology level would be a minimum of 25 percent, and the estimated costs would be \$500 million. As described earlier, since all in-production engines meet the in-production standards and nearly all in-production engines meet these new type standards—even though they do not have to, we believe that there would not be costs, nor emission reductions, from the proposed rule. Also, because current in-production engines would not be required to make any changes under this proposed rule, there will not be any adverse impact on noise and safety of these engines. Likewise, the noise and safety of future type designs should not be adversely impacted by compliance with these proposed new type standards since all manufacturers currently have engines that meet that level.

Following the final rulemaking for the PM standards, the FAA would issue a rulemaking to enforce compliance to these standards, and any anticipated certification costs for the PM standards would be estimated by FAA. The EPA is not making any attempt to quantify the costs associated with certification actions required by the FAA to enforce these standards.

As described earlier, manufacturers have already developed or are developing technologies to respond to ICAO standards that are equivalent to the proposed standards, and they will

comply with the ICAO standards in the absence of U.S. regulations. Also, domestic implementation of the ICAO standards would potentially provide for a cost savings to U.S. manufacturers since it would enable them to certify their aircraft engine (via subsequent FAA rulemaking) domestically instead of having to certificate with a foreign authority (which would occur without this EPA rulemaking). If the proposed PM standards, which would match the ICAO standards, are not ultimately adopted in the United States, U.S. civil aircraft engine manufacturers will have to certify to the ICAO standards at higher costs because they will have to move their entire certification program(s) to a non-U.S. certification authority.<sup>134</sup> Thus, there would be no new certification costs for the proposed rule, and the proposed rule could potentially provide a costs savings.

For the same reasons there would be no NRC and certification costs for the proposed rule as discussed earlier, there would be no recurring costs (recurring operating and maintenance costs) for the proposed rule. The elements of recurring costs would include additional maintenance, material, labor, and tooling costs.

As described earlier in Section IV.E, the EPA is proposing to formally incorporate the PM aspects of the existing information collection request (ICR) into the CFR (or regulations) in the proposed section 1031.150. This proposed action would not create a new requirement for the manufacturers of aircraft engines. Instead, it would simply incorporate the existing reporting requirements into the CFR for ease of use by having all the reporting requirements readily available in the CFR. Thus, this proposed action would not create new costs.

#### *E. Summary of Benefits and Costs*

The proposed standards match the ICAO standards, and ICAO intentionally established its standards at a level which is technology following. In doing this, ICAO adheres to its technical feasibility definition for the standard setting process, which is meant to consider the emissions performance of existing in-production engines and those engines expected to be in production by 2023. Independent of the ICAO standards all engines currently manufactured will meet the ICAO in-production standards, and nearly all these same engines will meet the new

type standards—even though these new type standards do not apply to in-production engines. Therefore, there would be no costs and no additional benefits from complying with these proposed standards—beyond the benefits from maintaining consistency or harmonizing with the international standards and preventing backsliding by ensuring that all in-production and new type engines have at least the PM emission levels of today's aircraft engines.

#### **VII. Technical Amendments**

In addition to the PM-related regulatory provisions discussed earlier in this document, the EPA is proposing technical amendments to the regulatory text that apply more broadly than to just the proposed new PM standards. First, the EPA is proposing to migrate the existing aircraft engine emissions regulations from 40 CFR part 87 to a new 40 CFR part 1031. Along with this migration, the EPA is proposing to restructure the regulations to allow for better ease of use and allow for more efficient future updates. The EPA is also proposing to delete some regulatory provisions and definitions that are unnecessary, as well as make several other minor technical amendments to the regulations. Finally, as explained in more detail below, EPA is also proposing revisions to 40 CFR part 87 to provide continuity during the transition of 40 CFR part 87 to 40 CFR part 1031.

##### *A. Migration of Regulatory Text to New Part*

In the 1990s, the EPA began an effort to migrate all transportation-related air emissions regulations to new parts, such that all mobile source regulations are contained in a single group of contiguous parts of the CFR. In addition to the migration, that effort has included clarifications to regulations and improvements to the ease of use through plain language updates and restructuring. To date, the aircraft engine emission regulations contained in 40 CFR part 87 are the only mobile source emission regulations which have not undergone this migration and update process.

The current 40 CFR part 87 was initially drafted in the early 1970s and has seen numerous updates and revisions since then. This has led to a set of aircraft engine emission regulations that is difficult to navigate and contains numerous unnecessary provisions. Further, the current structure of the regulations would make the adoption of the PM standards proposed in this document, as well as any future standards the EPA may

<sup>134</sup> In addition, European authorities charge fees to aircraft engine manufacturers for the certification of their engines, but FAA does not charge fees for certification.

propose, difficult to incorporate into the existing regulatory structure.

Therefore, the EPA is proposing to migrate the existing aircraft engine regulations from 40 CFR part 87 to a new 40 CFR part 1031, directly after the airplane GHG standards contained in 40 CFR part 1030. In the process, the EPA is proposing to restructure, streamline and clarify the regulatory provisions for ease of use and to facilitate more efficient future updates. Finally, the EPA is proposing to delete unnecessary regulatory provisions, which are discussed in detail in the next section.

This regulatory migration and restructuring effort is not intended to change any substantive provision of the existing regulatory provisions. Thus, the EPA is not seeking comment on the proposed migration and restructuring, except in cases where a commenter believes that the proposed structure unintentionally changes the meaning of the regulatory text. The following two sections on the deletion of unnecessary provisions and additional technical amendments specify areas where the EPA invites comment on proposed changes to the regulations separate from the proposed migration and restructuring.

As is noted in the amendatory text to the proposed regulations, the EPA is proposing to make this transition effective on January 1, 2023. The new 40 CFR part 1031 would become effective (*i.e.*, be incorporated into the Code of Federal Regulations) 30 days following the publication of the final rule in the **Federal Register**. However, the applicability language in the proposed section 1031.1 indicates that the new 40

CFR part 1031 would apply to engines subject to the standards beginning January 1, 2023. Prior to January 1, 2023, the existing 40 CFR part 87 would continue to apply. On January 1, 2023, the existing 40 CFR part 87 would be replaced with a significantly abbreviated version of 40 CFR part 87 whose sole purpose would be to direct readers to the new 40 CFR part 1031. Additionally, a reference in the current 40 CFR part 1030 to 40 CFR part 87 would be updated to reference 40 CFR part 1031 at that time. The purpose of the abbreviated 40 CFR part 87 is to accommodate any references to 40 CFR part 87 that currently exist in the type certification documentation and advisory circulars issued by the FAA, as well as any other references to 40 CFR part 87 that currently exist elsewhere. Since it would be extremely difficult to identify and update all such documents prior to January 1, 2023, the EPA is instead proposing to adopt language in 40 CFR part 87 that simply states the provisions relating to a particular section of the 40 CFR part 87 apply as described in a corresponding section of the proposed new 40 CFR part 1031.

*B. Deletion of Unnecessary Provisions*

As previously mentioned, the existing aircraft engine emissions regulations contain some unnecessary provisions which the EPA proposes to delete. These proposed deletions include transitional exemption provisions that are no longer available, several definitions, and some unnecessary language regarding the Secretary of the Department of Transportation, as detailed in the following paragraphs.

The EPA is proposing to not migrate the current 40 CFR 87.23(d)(1) and (3) to the new 40 CFR part 1031. Both these paragraphs contain specific phase-in provisions available for a short period after the Tier 6 NO<sub>x</sub> standards began to apply, and their availability as compliance provisions ended on August 31, 2013. Thus, they are no longer needed. It should be noted that while the EPA is proposing to effectively delete these provisions by not migrating them to the proposed new 40 CFR part 1031, the underlying standards referred to in these provisions (*i.e.*, the Tier 4 and 6 NO<sub>x</sub> standards) are proposed to remain unchanged. Thus, the underlying certification basis for any engines certificated under these provisions will remain intact.

The EPA is also proposing to delete a number of definitions from the current 40 CFR part 87 as it is migrated to the new proposed Part 1031 for two reasons. First, in the effort to streamline and clarify the regulations, some of these definitions have effectively been incorporated directly into the regulatory text where they are used, making a standalone definition unnecessary and redundant. Second, some of these definitions are simply not needed for any regulatory purpose and are likely artifacts of previous revisions to the regulations (*e.g.*, where a regulatory provision was deleted but the associated definition was not).

The definitions that the EPA proposes to delete and the reasons for the proposed deletions are listed in Table VII-1.

TABLE VII-1—LIST OF TERMS FOR WHICH DEFINITIONS ARE PROPOSED TO BE DELETED

Term	Reason for proposed deletion
Act .....	Not used in the regulatory text.
Administrator .....	No longer needed as not used in proposed revised and streamlined regulatory text.
Class TP .....	No longer needed as definition was effectively incorporated into regulatory text during proposed migration.
Class TF .....	No longer needed as definition was effectively incorporated into regulatory text during proposed migration.
Class T3 .....	No longer needed as definition was effectively incorporated into regulatory text during proposed migration.
Class T8 .....	No longer needed as definition was effectively incorporated into regulatory text during proposed migration.
Class TSS .....	No longer needed as definition was effectively incorporated into regulatory text during proposed migration.
Commercial aircraft .....	No longer needed as not used in proposed revised and streamlined regulatory text.
Commercial aircraft gas turbine engine .....	No longer needed as not used in proposed revised and streamlined regulatory text.
Date of introduction .....	Unnecessary definition that is not used in existing regulatory text and not needed in revised regulatory text.
Engine .....	For regulatory purposes, definition of engine not needed given existing definitions of Aircraft engine, Engine model, and Engine sub-model.
In-use aircraft gas turbine engine ...	No longer needed in light of proposed deletion of unnecessary provisions and technical amendments to fuel venting requirements.
Military aircraft .....	Not needed as regulatory text applies to commercial engines.
Operator .....	No longer needed as not used in proposed revised and streamlined regulatory text.
Production cutoff or the date of production cutoff.	No longer needed with proposed deletion of unnecessary exemption provisions and streamlining of exemption regulatory text.
Tier 0 .....	No longer needed as definition was effectively incorporated into regulatory text during proposed migration.
Tier 2 .....	No longer needed as definition was effectively incorporated into regulatory text during proposed migration.
Tier 4 .....	No longer needed as definition was effectively incorporated into regulatory text during proposed migration.
Tier 6 .....	No longer needed as definition was effectively incorporated into regulatory text during proposed migration.
Tier 8 .....	No longer needed as definition was effectively incorporated into regulatory text during proposed migration.

TABLE VII-1—LIST OF TERMS FOR WHICH DEFINITIONS ARE PROPOSED TO BE DELETED—Continued

Term	Reason for proposed deletion
U.S.-registered aircraft .....	Unnecessary term that is not used in the regulatory text.

The EPA is also proposing to not migrate the current 40 CFR 87.3(b) to the new 40 CFR part 1031, which in effect will result in its deletion. This paragraph is simply a restatement of an obligation directly imposed under the Clean Air Act the Secretary shall issue regulations to assure compliance with the regulations issued under the Act. This is not a regulatory requirement related to the rest of the part, and as such it is not needed in the proposed 40 CFR part 1031.

*C. Other Technical Amendments and Minor Changes*

In addition to the migration of the regulations to a new part and the removal of unnecessary provisions just discussed, the EPA is proposing some minor technical amendments to the regulations.

The EPA is proposing to add definitions for “Airplane” and “Emission index.” Both these terms are used in the current aircraft engine emissions regulations, but they are currently undefined. The new proposed definitions would help provide clarity to the provisions that utilize those terms.

The EPA proposes to modify the definitions for “Exception” and “Exemption.” The current definitions of these terms in Part 87.1 go beyond simply defining the terms and contain what could more accurately be described as regulatory requirements stating what provisions an excepted or exempted engine must meet. These portions of the definitions, which are more accurately described as regulatory requirements, are proposed to be moved to the introductory text in 1031.15 and 1031.20, as applicable. These proposed changes are in no way intended to change any regulatory requirement applicable to excepted or exempted engines. Rather, they are proposed simply to more clearly separate definitions from the related regulatory requirements.

The EPA is proposing to not migrate the existing 87.42(d) to the proposed new Part 1031, which in effect will result in the deletion of this provision. This paragraph in the annual production report section regards the identification and treatment of confidential business information (CBI) in manufacturers’ annual production reports. The EPA is instead relying on

the existing CBI regulations in 40 CFR 1068.10 (as referenced in the proposed 1031.170). This proposed change would have no impact on the ability of manufacturers to make claims of CBI, or in the EPA’s handling of such claims. However, it would assure a more consistent treatment of CBI across mobile source programs.

The EPA is proposing a minor change to the existing emissions requirements for spare engines, as found in 87.50(c)(2). In the proposed regulatory text for 1031.20(a), the EPA is proposing to delete the existing provision that a spare engine is required to meet standards applicable to Tier 4 or later engines (currently contained in 40 CFR 87.50(c)(2)). The EPA is proposing to retain and migrate to part 1031 the requirement in 40 CFR 87.50(c)(3) such that a spare engine would need to be certificated to emission standards equal to or lower than those of the engines they are replacing, for all regulated pollutants. This proposed deletion of 40 CFR 87.50(c)(2) would align with ICAO’s current guidance on the emissions of spare engines and is consistent with U.S. efforts to secure the highest practicable degree of uniformity in aviation regulations and standards. The EPA does not believe this proposed change would have any impact on current industry practices. Deleting the provision currently in 40 CFR 87.50(c)(2) would leave in place the requirement that any new engine manufactured as a spare would need to be at least as clean as the engine it is replacing (as stated in the current 40 CFR 87.50(c)(3)), but with no requirement that it meet standards applicable to Tier 4 or later engines. Thus, under this proposed deletion a new spare engine could, in theory, be manufactured that only met pre-Tier 4 standards. The Tier 4 standards became effective in 2004, so the proposed deletion would only impact spare engines manufactured to replace engines manufactured roughly before 2004. It is extremely unlikely that a manufacturer would build a new engine as a replacement for such an old design as it would be very disruptive to the manufacturing of current designs for new aircraft. Rather, it is common practice that spares for use in replacing older engines would not be newly manufactured engines of an old design,

but engines that have been taken from similar aircraft that have been retired. The EPA does not believe that any engines would be manufactured to pre-Tier 4 designs for use as spare engines given current practices. Thus, the EPA does not believe that this proposed deletion of 40 CFR 87.50(c)(2) for the purposes of uniformity would have any practical impact on current industry practices.

The EPA is proposing to align the applicability of smoke number standards for engines used in supersonic airplanes with ICAO’s applicability. The EPA adopted emission standards for engines used on supersonic airplanes in 2012.<sup>135</sup> Those standards were equivalent to ICAO’s existing standards with one exception. ICAO’s emission standards fully apply to all engines to be used on supersonic airplanes, regardless of rated output. In an apparent oversight, the EPA only applied the smoke number standards to engines of greater than or equal to 26.7 kN rated output. Thus, the EPA is proposing to apply smoke number standards to include engines below 26.7 kN rated output for use on supersonic airplanes which are equivalent to ICAO’s provisions. This change is proposed consistent with U.S. efforts to secure the highest practicable degree of uniformity in aviation regulations and standards and would have no practical impact on engine manufacturers. The EPA is currently unaware of any engines in production which could be used on supersonic airplanes, and those being developed for application to future supersonic airplanes are expected to be well above 26.7 kN rated output, and thus, they would be covered by the existing smoke number standard. Throughout its regulations, the EPA is proposing to align with ICAO regarding a common rated output threshold for emission regulations. The applicability and/or stringency of several aircraft engine emission standards can be different depending on whether an engine’s rated output is above or below 26.7 kN. In the ICAO regulations, the threshold is consistently stated as either greater than, or less than or equal to 26.7 kN. In the current 40 CFR part 87, the equal to portion of the threshold is applied inconsistently. In some cases, it

<sup>135</sup> 77 FR 36342, June 18, 2012.

is expressed as less than, and greater than or equal to. In other cases, it is expressed as greater than, and less than or equal to. The proposal is to make all instances in the proposed Part 1031 consistent with ICAO, *i.e.*, greater than, and less than or equal to. As there are no current engines with a rated output of exactly at 26.7 kN, this proposed change would have no practical impact. However, it is consistent with U.S. efforts to secure the highest practicable degree of uniformity in aviation regulations and standards.

The EPA is proposing to incorporate by reference Appendix 1 of ICAO's Annex 16, Volume II. This appendix deals with the determination of a test engine's reference pressure ratio, and its exclusion from the U.S. regulations was an oversight. Other Annex 16, Volume II appendices which contain test procedures, fuel specifications, and other compliance-related provisions have been incorporated by reference into the U.S. regulations for many years, and it is important to correct this oversight so that the complete testing and compliance provisions are clear.

The EPA is proposing to streamline, restructure, and update the exemption provisions currently in 40 CFR 87.50. First, this section contains provisions regarding exemptions, exceptions, and annual reporting provisions relating to exempted and excepted engines. The EPA is proposing to migrate the exceptions section concerning spare engines (87.50(c)) to its own new section 1031.20(a), with the proposed changes discussed earlier in this section. The provisions regarding the annual reporting of exempted and excepted engines are proposed to be incorporated into the new annual reporting section 1031.150. These reporting provisions otherwise remain unchanged. Section 87.50(a), regarding engines installed on new aircraft, and section 87.50(b), regarding temporary exemptions based on flights for short durations at infrequent intervals, are proposed to be migrated to a new section 1031.15. The temporary exemptions provisions remain unchanged, with the exception of the addition of "of Transportation" after "Secretary" in 1031.15(b)(4) to provide additional clarity. The proposed changes to the exemptions for engines installed on new aircraft are a bit more extensive, as discussed in the next paragraph.

In 2012, the EPA adopted new exemption provisions specifically to provide flexibility during the transition to Tier 6 and Tier 8 NO<sub>x</sub> standards.<sup>136</sup>

These provisions were only available through December 31, 2016 and are proposed to be deleted, as previously discussed. However, during the adoption of those transitional flexibilities, the EPA inadvertently replaced the existing exemption provisions with the new transitional provisions rather than appending the transitional provisions to the existing ones. This left 87.50 with no general exemption language, only those provisions specific to the newly adopted NO<sub>x</sub> standards. Given that the transitional NO<sub>x</sub> exemption provisions have expired and are now obsolete, the EPA is proposing to delete them rather than migrate them to the new 1031.15. The EPA is further proposing to restore the general exemption authority that was inadvertently removed in 2012. In a recent action which established GHG standards for airplanes, the EPA adopted much more streamlined exemption provisions for airplanes in consultation with the FAA.<sup>137</sup> The EPA is proposing to adopt similarly streamlined general exemption provisions for aircraft engines as well, as contained in the proposed 1031.15(a).

The EPA is proposing some changes relative to the prohibition on fuel venting. The fuel venting standard is intended to prevent the discharge of fuel to the atmosphere following engine shutdown, as explicitly stated in 40 CFR 87.11(a). The existing definition for fuel venting emissions in 87.1 defines fuel venting emissions as fuel discharge during all normal ground and flight operations. As the standard section itself limits the applicability only to venting that occurs following engine shutdown, consistent with ICAO's fuel venting provisions, the EPA is proposing to delete the definition for fuel venting emissions as both unnecessary and contradictory to the actual requirement. Further, the EPA is proposing to add the word "liquid" before fuel in the fuel venting requirements, consistent with the ICAO fuel venting provisions. Neither of these proposed changes would have any practical effect on the requirements on engine manufacturers, but these changes both clarify the requirements and fully align with ICAO standards and recommended practices, consistent with U.S. efforts to secure the highest practicable degree of uniformity in aviation regulations and standards.

The EPA is proposing to modify the applicability date language associated with the standards applicable to Tier 8 engines, as contained in the proposed 1031.60(e)(2). The applicability of new

type standards has traditionally been linked to the date of the first individual production engine of a given type, both for EPA regulations and ICAO regulations. This approach has been somewhat cumbersome in the past because a manufacturer would have to estimate what standards would be in effect when actual production of a new type began in order to determine to what standards a new type engine would be subject. Given that the engine type certification process can take up to three years, this approach has proven problematic during periods of transition from one standard to another. To address this concern, ICAO agreed at the CAEP/11 meeting in 2019 to transition from the date of manufacture of the first production engine to the date of application for a type certificate to determine standards applicability for new types. The EPA was actively involved in the deliberations that led to this agreement and supported the transition from date of first individual production model to date of application for type certification as the basis for standards applicability in the future. This approach is reflected in the applicability date provisions of the proposed PM standards, consistent with ICAO. The EPA is also proposing to adopt it for existing standards applicable to Tier 8 engines as well. This proposed change would have no impact on manufacturers as the existing standards applicable to Tier 8 engines have been in place since 2014, and there are no new gaseous or smoke number standards set to take effect for such engines. Thus, this proposed change is solely intended to improve consistency with ICAO and to structure the regulations such that the adoption of any future standards using this applicability date approach would be straightforward.

The EPA is proposing to revise the definition of "date of manufacture" by replacing "competent authority" with "recognized airworthiness authority" in two places. The term "competent" has no specific meaning in the context of either the EPA's or the FAA's regulations. However, the FAA does recognize other airworthiness authorities for engines certificated outside the United States, as indicated through existing bilateral agreements with such authorities. Also, the EPA is proposing to update its definition of "supersonic" by replacing it with a new definition of "supersonic airplane." The proposed new definition for "supersonic airplane" is based on a revised definition for such proposed by the FAA in a recent proposed action

<sup>136</sup> 77 FR 36342, June 18, 2012.

<sup>137</sup> 86 FR 2136, January 11, 2021.

regarding noise regulations for supersonic airplanes.<sup>138</sup> This proposed new definition would provide greater assurance that the proposed standards applicable to engines used on supersonic airplanes would apply to the engines for which they are intended.

The EPA is proposing to update several definitions and align them with definitions included in the recent airplane GHG regulations.<sup>139</sup> The definitions proposed to be updated are for “Aircraft,” “Aircraft engine,” “Airplane,” “Exempt,” and “Subsonic.” These definitions are proposed to be updated in the aircraft engine regulations simply for consistency with the airplane GHG regulations and with FAA regulations. The changes being proposed would not have any impact on the regulatory requirements related to the definitions.

The EPA is also proposing to address an unintentional applicability gap related to EPA’s airplane GHG standards that could potentially exclude some airplanes from being subject to the standards. The intention of the international standards was to cover all jet airplanes with an MTOM greater than 5,700 kg. At ICAO it was agreed that airplanes with an MTOM less than 60,000 kg and with 19 seats or fewer could have extra time to comply with the standards (incorporated at 40 CFR 1030.1(a)(2)). With that in mind, 40 CFR 1030.1(a)(1) was written to cover airplanes with 20 or more seats and an MTOM greater than 5,700 kg. However, this means that airplanes with 19 seats or fewer and an MTOM greater than 60,000 kg are not covered by the current regulations but would be covered by the ICAO CO<sub>2</sub> standard. While the EPA is not aware of any airplanes in this size range, the intent of the EPA’s GHG rule was to cover all jet airplanes with MTOM greater than 5,700 kg. The EPA is proposing to adopt new language at 40 CFR 1030.1(a)(1)(iv)–(vi) to cover these airplanes, should they be produced. This proposed change would expand the current applicability of the GHG standards on the date this final rulemaking goes into effect. However, airplanes in this size category were considered as part of the GHG standard setting process and had been intended to be subject to the GHG standards.

The EPA is proposing to correct the effective date of new type design GHG standards for turboprop airplanes (with a maximum takeoff mass greater than 8,618 kg), which is currently specified in 40 CFR 1030.1(a)(3)(ii) as January 1, 2020. The EPA did not intend to

retroactively apply these standards using the ICAO new type start date for these airplanes. Rather, this effective date should have been January 11, 2021, to be consistent with the effective date of new type standards for other categories of airplanes in this part (e.g., 40 CFR 1030.1(a)(1)). Based on consultations with the FAA, this proposed change to part 1030 will not impact any airplanes.

Finally, the EPA is proposing a minor word change to the existing applicability language in 40 CFR part 1030 in order to make it consistent with the current applicability language in the EPA’s airplane engine regulations as well as FAA regulations. Specifically, the current language in 40 CFR 1030.1(c)(7) refers to airplanes powered with piston engines. The EPA is proposing to replace the word “piston” with “reciprocating” in 40 CFR 1030.1(c)(7) to align it with the existing 40 CFR 87.3(a)(1), the proposed language in 40 CFR 1031.1(b)(1), and existing FAA regulations in 14 CFR parts 1 and 33. This proposed change is for consistency among federal regulations and to avoid any confusion that may be caused by the use of two different terms. This proposed change would have no material impact on the meaning of the regulatory text.

### VIII. Statutory Authority and Executive Order Reviews

Additional information about these statutes and Executive orders can be found at <https://www.epa.gov/laws-regulations/laws-and-executive-orders>.

#### A. Executive Order 12866: Regulatory Planning and Review and Executive Order 13563: Improving Regulation and Regulatory Review

This action is a significant regulatory action that was submitted to the Office of Management and Budget (OMB) for review. This action raises “. . . novel legal or policy issues arising out of legal mandates, the President’s priorities, or the principles set forth in this Executive Order.” This action promulgates new aircraft engine emissions regulations and as such, requires consultation and coordination with the Federal Aviation Administration (FAA). Accordingly, the EPA submitted this action to the OMB for review under E.O. 12866 and E.O. 13563. Any changes made in response to OMB recommendations have been documented in the docket. Section VI.E of this preamble summarizes the cost and benefits of this action.

#### B. Paperwork Reduction Act (PRA)

This action does not impose any new information collection burden under the

PRA. OMB has previously approved the information collection activities contained in the existing regulations and has assigned OMB control number 2060–0680. This proposed rule would codify that existing collection by including the current nvPM data collection in the proposed regulatory text, but it would not add any new reporting requirements.

#### C. Regulatory Flexibility Act (RFA)

I certify that this action will not have a significant economic impact on a substantial number of small entities under the RFA. Among the potentially affected entities (manufacturers of aircraft engines) there is only one small entity, and that aircraft engine manufacturer does not make engines in the category subject to the proposed new provisions contained in this document (i.e., engines greater than 26.7 kN rated output) and has not indicated any plans to begin such production. Therefore, this action will not impose any requirements on small entities. Supporting information can be found in the docket.<sup>140</sup>

#### D. Unfunded Mandates Reform Act (UMRA)

This action does not contain any unfunded mandate as described in UMRA, 2 U.S.C. 1531–1538, and does not significantly or uniquely affect small governments. The action imposes no enforceable duty on any state, local or tribal governments or the private sector.

#### E. Executive Order 13132: Federalism

This action does not have federalism implications. It will not have substantial direct effects on the states, on the relationship between the national government and the states, or on the distribution of power and responsibilities among the various levels of government.

#### F. Executive Order 13175: Consultation and Coordination With Indian Tribal Governments

This action does not have tribal implications as specified in Executive Order 13175. This action regulates the manufacturers of aircraft engines and will not have substantial direct effects on one or more Indian tribes, on the relationship between the Federal Government and Indian tribes, or on the distribution of power and

<sup>140</sup> U.S. EPA, 2021: *Determination of no SISNOSE for Proposed Aircraft Engine Emission Standards*, Memorandum to Docket ID No. EPA–HQ–OAR–2019–0660. This memorandum describes that the only small entity is Williams Int’l, which only make engines below 26.7 kN. Thus, they are not subject to the proposed standards.

<sup>138</sup> 85 FR 20431, April 13, 2020.

<sup>139</sup> 86 FR 2136, January 11, 2021.



responsibilities between the Federal Government and Indian tribes. Thus, Executive Order 13175 does not apply to this action.

*G. Executive Order 13045: Protection of Children From Environmental Health Risks and Safety Risks*

This action is not subject to Executive Order 13045 because it is not economically significant as defined in Executive Order 12866. This action’s health and risk assessments are contained in Section III.

*H. Executive Order 13211: Actions Concerning Regulations That Significantly Affect Energy Supply, Distribution or Use*

This action is not a “significant energy action” because it is not likely to have a significant adverse effect on the supply, distribution or use of energy. These aircraft engine emissions regulations are not expected to result in any changes to aircraft fuel consumption.

*I. National Technology Transfer and Advancement Act (NTTAA)*

This action involves technical standards for testing emissions for aircraft gas turbine engines. EPA is proposing to use test procedures contained in ICAO’s International

Standards and Recommended Practices Environmental Protection, Annex 16, Volume II along with the modifications contained in this rulemaking as described in Section IV. These procedures are currently used by all manufacturers of aircraft gas turbine engines to demonstrate compliance with ICAO emissions standards.

In accordance with the requirements of 1 CFR 51.5, we are incorporating by reference the use of test procedures contained in ICAO’s International Standards and Recommended Practices Environmental Protection, Annex 16, Volume II, along with the modifications contained in this rulemaking. This includes the following standards and test methods:

Standard or test method	Regulation	Summary
ICAO 2017, <i>Aircraft Engine Emissions</i> , Annex 16, Volume II, Fourth Edition, July 2017, as amended by Amendment 10, January 1, 2021.	40 CFR 1031.140(a), (b), (f), (g), and (h), and 40 CFR 1031.205.	Test method describes how to measure PM, gaseous and smoke emissions from aircraft engines.

The version of the ICAO Annex 16, Volume II that is proposed to be incorporated into the new 40 CFR part 1031 is the same version that is currently incorporated by reference in 40 CFR 87.1, 40 CFR 87.42(c), and 40 CFR 87.60(a) and (b).

The referenced standards and test methods may be obtained through the International Civil Aviation Organization, Document Sales Unit, 999 University Street, Montreal, Quebec, Canada H3C 5H7, (514) 954–8022, [www.icao.int](http://www.icao.int), or [sales@icao.int](mailto:sales@icao.int).

*J. Executive Order 12898: Federal Actions to Address Environmental Justice in Minority Populations and Low-Income Populations*

The EPA believes that this action does not have disproportionately high and adverse human health or environmental effects on minority populations, low-income populations and/or indigenous peoples, as specified in Executive Order 12898 (59 FR 7629, February 16, 1994). This proposed action would not achieve emission reductions and would therefore result in no improvement in per-aircraft emissions for all communities living near airports. EPA describes in Section III.G the existing literature reporting on disparities in potential exposure to aircraft emissions for people of color and low-income populations. EPA, in an action separate from this proposed rulemaking, will be conducting an analysis of the

communities residing near airports where jet aircraft operate in order to more fully understand disproportionately high and adverse human health or environmental effects on people of color, low-income populations and/or indigenous peoples, as specified in Executive Order 12898. The results of this analysis could help inform additional policies to reduce pollution in communities living in close proximity to airports.

**List of Subjects**

40 CFR Parts 87 and 1031

Environmental protection, Air pollution control, Aircraft, Incorporation by reference.

40 CFR Part 1030

Environmental protection, Air pollution control, Aircraft, Greenhouse gases.

Michael S. Regan,  
Administrator.

For the reasons set forth in the preamble, EPA proposes to amend 40 CFR parts 87, 1030, and 1031 as follows:

**PART 87—CONTROL OF AIR POLLUTION FROM AIRCRAFT AND AIRCRAFT ENGINES**

- 1. Revise part 87 to read as follows:

**PART 87—CONTROL OF AIR POLLUTION FROM AIRCRAFT AND AIRCRAFT ENGINES**

- 87.1 Definitions.
- 87.2 Abbreviations.
- 87.3 General applicability and requirements.
- 87.10 Applicability—fuel venting.
- 87.11 Standard for fuel venting emissions.
- 87.20 Applicability—exhaust emissions.
- 87.21 Exhaust emission standards for Tier 4 and earlier engines.
- 87.23 Exhaust emission standards for Tier 6 and Tier 8 engines.
- 87.31 Exhaust emission standards for in-use engines.
- 87.48 Derivative engines for emissions certification purposes.
- 87.50 Exemptions and exceptions.
- 87.60 Testing engines.

**Authority:** 42 U.S.C. 7401 *et seq.*

**§ 87.1 Definitions.**

Definitions apply as described in 40 CFR 1031.205.

**§ 87.2 Abbreviations.**

Abbreviations apply as described in 40 CFR 1031.200.

**§ 87.3 General applicability and requirements.**

Provisions related to the general applicability and requirements of aircraft engine standards apply as described in 40 CFR 1031.1.

**§ 87.10 Applicability—fuel venting.**

Fuel venting standards apply to certain aircraft engines as described in 40 CFR 1031.30(b).

**§ 87.11 Standard for fuel venting emissions.**

Fuel venting standard apply as described in 40 CFR 1031.30(b).

**§ 87.20 Applicability—exhaust emissions.**

Exhaust emission standards apply to certain aircraft engines as described in 40 CFR 1031.40 through 1031.90.

**§ 87.21 Exhaust emission standards for Tier 4 and earlier engines.**

Exhaust emission standards apply to new aircraft engines as described in 40 CFR 1031.40 through 1031.90.

**§ 87.23 Exhaust emission standards for Tier 6 and Tier 8 engines.**

Exhaust emission standards apply to new aircraft engines as follows:

(a) New turboprop aircraft engine standards apply as described in 40 CFR 1031.40.

(b) New supersonic engine standards apply as described in 40 CFR 1031.90.

(c) New subsonic turbofan or turbojet aircraft engine standards apply as follows:

(1) Standards for engines with rated output at or below 26.7 kN thrust apply as described in 40 CFR 1031.50.

(2) Standards for engines with rated output above 26.7 kN thrust apply as described in 40 CFR 1031.60.

(d) NO<sub>x</sub> standards apply based on the schedule for new type and in-production aircraft engines as described in 40 CFR 1031.60.

**§ 87.31 Exhaust emission standards for in-use engines.**

Exhaust emission standards apply to in-use aircraft engines as described in 40 CFR 1031.60.

**§ 87.48 Derivative engines for emissions certification purposes.**

Provisions related to derivative engines apply as described in 40 CFR 1031.130.

**§ 87.50 Exemptions and exceptions.**

Provisions related to exceptions apply as described in 40 CFR 1031.11.

Provisions related to exemptions apply as described in 40 CFR 1031.10.

**§ 87.60 Testing engines.**

Test procedures for measuring gaseous emissions and smoke number apply as described in 40 CFR 1031.140.

**PART 1030—CONTROL OF GREENHOUSE GAS EMISSIONS FROM ENGINES INSTALLED ON AIRPLANES**

■ 2. The authority citation for part 1030 continues to read as follows:

Authority: 42 U.S.C. 7401–7671q.

■ 3. Amend § 1030.1 by:

■ a. Revising paragraphs (a) introductory text and (a)(1)(iii);

■ b. Adding paragraphs (a)(1)(iv) through (vi);

■ c. Revising paragraphs (a)(3)(ii) and (c)(7).

The revisions and additions read as follows:

**§ 1030.1 Applicability.**

(a) Except as provided in paragraph (c) of this section, when an aircraft engine subject to 40 CFR part 1031 is installed on an airplane that is described in this section and subject to title 14 of the Code of Federal Regulations, the airplane may not exceed the Greenhouse Gas (GHG) standards of this part when original civil certification under title 14 is sought.

(1) \* \* \*

(iii) An application for original type certification that is submitted on or after January 11, 2021; or

(iv) A type-certificated maximum passenger seating capacity of 19 seats or fewer, and

(v) A MTOM greater than 60,000 kg, and

(vi) An application for original type certification that is submitted on or after [DATE OF PUBLICATION OF FINAL RULE IN THE FEDERAL REGISTER].

\* \* \* \* \*

(3) \* \* \*

(ii) An application for original type certification that is submitted on or after January 11, 2021.

\* \* \* \* \*

(c) \* \* \*

(7) Airplanes powered by reciprocating engines.

■ 4. Add part 1031 to read as follows:

**PART 1031—CONTROL OF AIR POLLUTION FROM AIRCRAFT ENGINES****Subpart A—Scope and Applicability**

1031.1 Applicability.

1031.5 Engines installed on domestic and foreign aircraft.

1031.10 State standards and controls.

1031.15 Exemptions.

1031.20 Exceptions.

**Subpart B—Emission Standards and Measurement Procedures**

1031.30 Overview of emission standards and general requirements.

1031.40 Turboprop engines.

1031.50 Subsonic turbojet and turbofan engines at or below 26.7 kN thrust.

1031.60 Subsonic turbojet and turbofan engines above 26.7 kN thrust.

1031.90 Supersonic Engines.

1031.130 Derivative engines for emissions certification purposes.

1031.140 Test procedures

**Subpart C—Reporting and Recordkeeping**

1031.150 Production reports.

1031.160 Recordkeeping.

1031.170 Confidential business information.

**Subpart D—Reference Information**

1031.200 Abbreviations.

1031.205 Definitions.

1031.210 Incorporation by reference.

Authority: –42 U.S.C. 7401–7671q.

**Subpart A—Scope and Applicability****§ 1031.1 Applicability.**

This part applies to aircraft gas turbine engines on and after January 1, 2023. Emission standards apply as described in subpart B of this part.

(a) Except as provided in paragraph (b) of this section, the regulations of this part apply to aircraft engines subject to 14 CFR part 33.

(b) The requirements of this part do not apply to the following aircraft engines:

(1) Reciprocating engines (including engines used in ultralight aircraft).

(2) Turboshift engines such as those used in helicopters.

(3) Engines used only in aircraft that are not airplanes.

(4) Engines not used for propulsion.

**§ 1031.5 Engines installed on domestic and foreign aircraft.**

The Secretary of Transportation shall apply these regulations to aircraft of foreign registry in a manner consistent with obligations assumed by the United States in any treaty, convention or agreement between the United States and any foreign country or foreign countries.

**§ 1031.10 State standards and controls.**

No State or political subdivision of a State may adopt or attempt to enforce any aircraft or aircraft engine standard with respect to emissions unless the standard is identical to a standard that applies to aircraft or aircraft engines under this part.

**§ 1031.15 Exemptions.**

Individual engines may be exempted from current standards as described in this section. Exempted engines must conform to regulatory conditions specified for an exemption in this part and other applicable regulations. Exempted engines are deemed to be “subject to” the standards of this part

even though they are not required to comply with the otherwise applicable requirements. Engines exempted with respect to certain standards must comply with other standards as a condition of the exemption.

(a) Engines installed in new aircraft. Each person seeking relief from compliance with this part at the time of certification must submit an application for exemption to the FAA in accordance with the regulations of 14 CFR parts 11 and 34. The FAA will consult with the EPA on each exemption application request before the FAA takes action. Exemption requests under this paragraph (a) are effective only with FAA approval and EPA's written concurrence.

(b) Temporary exemptions based on flights for short durations at infrequent intervals. The emission standards of this part do not apply to engines that power aircraft operated in the United States for short durations at infrequent intervals. Exemption requests under this paragraph (b) are effective with FAA approval. Such operations are limited to:

(1) Flights of an aircraft for the purpose of export to a foreign country, including any flights essential to demonstrate the integrity of an aircraft prior to its flight to a point outside the United States.

(2) Flights to a base where repairs, alterations or maintenance are to be performed, or to a point of storage, and flights for the purpose of returning an aircraft to service.

(3) Official visits by representatives of foreign governments.

(4) Other flights the Secretary of Transportation determines to be for short durations at infrequent intervals. A request for such a determination shall be made before the flight takes place.

#### § 1031.20 Exceptions.

Individual engines may be excepted from current standards as described in this section. Excepted engines must conform to regulatory conditions specified for an exception in this part and other applicable regulations. Excepted engines are deemed to be "subject to" the standards of this part even though they are not required to comply with the otherwise applicable requirements. Engines excepted with respect to certain standards must comply with other standards from which they are not excepted.

(a) *Spare engines.* Newly manufactured engines meeting the definition of "spare engine" are automatically excepted as follows:

(1) This exception allows production of a newly manufactured engine for

installation on an in-use aircraft. It does not allow for installation of a spare engine on a new aircraft.

(2) Spare engines excepted under this paragraph (a) may be used only if they are certificated to emission standards equal to or lower than those of the engines they are replacing, for all regulated pollutants.

(3) Engine manufacturers do not need to request approval to produce spare engines, but must include information about spare engine production in the annual report specified in § 1031.150(d).

(4) The permanent record for each engine excepted under this paragraph (a) must indicate that the engine was manufactured as an excepted spare engine.

(5) Engines excepted under this paragraph (a) must be labeled with the following statement: "EXCEPTED SPARE".

(b) [Reserved]

### Subpart B—Emission Standards and Measurement Procedures

#### § 1031.30 Overview of emission standards and general requirements.

(a) *Overview of standards.* Standards apply to different types and sizes of aircraft engines as described in §§ 1031.40 through 1031.90. All new engines and some in-use engines are subject to smoke standards (either based on smoke number or nvPM mass concentration). Some new engines are also subject to standards for gaseous emissions (HC, CO, and NO<sub>x</sub>) and nvPM (mass and number).

(1) Where there are multiple tiers of standards for a given pollutant, the named tier generally corresponds to the meeting of the International Civil Aviation Organization's (ICAO's) Committee on Aviation Environmental Protection (CAEP) at which the standards were agreed to internationally. Other standards are named Tier 0, Tier 1, or have names that describe the standards.

(2) Where a standard is specified by a formula, determine the level of the standard as follows:

(i) For smoke number standards, calculate and round the standard to the nearest 0.1 smoke number.

(ii) For maximum nvPM mass concentration standards, calculate and round the standard to the nearest 1 µg/m<sup>3</sup>.

(iii) For LTO nvPM mass standards, calculate and round the standard to three significant figures.

(iv) For LTO nvPM number standards calculate and round the standard to three significant figures.

(v) For gaseous emission standards, calculate and round the standard to

three significant figures, or to the nearest 0.1 g/kN for turbojet and turbofan standards at or above 100 g/kN.

(3) Perform tests using the procedures specified in § 1031.140 to measure emissions for comparing to the standard. Engines comply with an applicable standard if test results show that the engine type certificate family's characteristic level does not exceed the numerical level of that standard.

(4) Engines that are covered by the same type certificate and are determined to be derivative engines for emissions certification purposes under the requirements of § 1031.130 are subject to the emission standards of the previously certified engine. Otherwise, the engine is subject to the emission standards that apply to a new engine type.

(b) *Fuel venting.* (1) The fuel venting standard in paragraph (b)(2) of this section applies to new subsonic and supersonic aircraft engines subject to this part. This fuel venting standard also applies to the following in-use engines:

(i) Turbojet and turbofan engines with rated output at or above 36 kN thrust manufactured after February 1, 1974.

(ii) Turbojet and turbofan engines with rated output below 36 kN thrust manufactured after January 1, 1975.

(iii) Turboprop engines manufactured after January 1, 1975.

(2) Engines may not discharge liquid fuel emissions into the atmosphere. This standard is directed at eliminating intentional discharge of liquid fuel drained from fuel nozzle manifolds after engines are shut down and does not apply to normal fuel seepage from shaft seals, joints, and fittings. Certification for the fuel venting standard will be based on an inspection of the method designed to eliminate these emissions.

#### § 1031.40 Turboprop engines.

The following standards apply to turboprop engines with rated output at or above 1,000 kW:

(a) *Smoke.* (1) Engines of a type or model for which the date of manufacture of the individual engine is on or after January 1, 1984, may not have a characteristic level for smoke number exceeding the following value:  
SN = 187-rO - 0.168

(2) [Reserved]

(b) [Reserved]

#### § 1031.50 Subsonic turbojet and turbofan engines at or below 26.7 kN thrust.

The following standards apply to new turbofan or turbojet aircraft engines with rated output at or below 26.7 kN thrust that are installed in subsonic aircraft:

(a) *Smoke.* (1) Engines of a type or model for which the date of

manufacture of the individual engine is on or after August 9, 1985 may not have a characteristic level for smoke number exceeding the lesser of 50 or the following value:

$$SN = 83.6 \cdot rO - 0.274$$

- (2) [Reserved]
- (b) [Reserved]

**§ 1031.60 Subsonic turbojet and turbofan engines above 26.7 kN thrust.**

The following standards apply to new turbofan or turbojet aircraft engines with rated output above 26.7 kN thrust that are installed in subsonic aircraft:

(a) *Smoke*. (1) Tier 0. Except as specified in (a)(2) of this section, engines of a type or model with rated output at or above 129 kN, and for which the date of manufacture of the individual engine after January 1, 1976 and is before January 1, 1984 may not have a characteristic level for smoke number exceeding the following emission standard:

$$SN = 83.6 \cdot rO - 0.274$$

(2) *JT8D and JT3D engines*. (i) Engines of the type JT8D for which the date of manufacture of the individual engine is on or after February 1, 1974 and before January 1, 1984 may not have a characteristic level for smoke number exceeding an emission standard of 30.

(ii) Engines of the type JT3D for which the date of manufacture of the individual engine is on or after January 1, 1978 and before January 1, 1984 may not have a characteristic level for smoke number exceeding an emission standard of 25.

(3) *Tier 0 in-use*. Except for engines of the type JT8D and JT3D, in-use engines with rated output at or above 129 kN thrust may not exceed the following smoke number standard:

$$SN = 83.6 \cdot rO - 0.274$$

(4) *JT8D in-use*. In-use aircraft engines of the type JT8D may not exceed a smoke number standard of 30.

(5) *Tier 1*. Engines of a type or model for which the date of manufacture of the individual engine is on or after January 1, 1984 and before January 1, 2023 may

not have a characteristic level for smoke number exceeding an emission standard that is the lesser of 50 or the following:  
 $SN = 83.6 \cdot rO - 0.274$

(6) *Tier 10*. Engines of a type or model for which the date of manufacture of the individual engine is on or after January 1, 2023 may not have a characteristic level for the maximum nvPM mass concentration in  $\mu\text{g}/\text{m}^3$  exceeding the following emission standard:

$$nvPM_{MC} = 10^{(3 + 2.9 \cdot rO - 0.274)}$$

(b) *LTO nvPM mass and number*. An engine's characteristic level for nvPM mass and nvPM number may not exceed emission standards as follows:

(1) *Tier 11 new type*. The following emission standards apply to engines of a type or model for which an application for original type certification is submitted on or after January 1, 2023 and for engines covered by an earlier type certificate if they do not qualify as derivative engines for emission purposes as described in § 1031.130:

TABLE 1 TO § 1031.60(b)(1)—TIER 11 NEW TYPE nvPM STANDARDS

Rated output (rO) in kN	nvPM <sub>mass</sub> in milligrams/kN	nvPM <sub>num</sub> in particles/kN
26.7 < rO ≤ 150	1251.1 – 6.914·rO	1.490·10 <sup>16</sup> – 8.080·10 <sup>13</sup> ·rO
rO > 150	214.0	2.780·10 <sup>15</sup>

(2) *Tier 11 in-production*. The following emission standards apply to engines of a type or model for which the

date of manufacture of the individual engine is on or after January 1, 2023:

TABLE 2 TO § 1031.60(b)(2)—TIER 11 IN-PRODUCTION nvPM STANDARDS

Rated output (rO) in kN	nvPM <sub>mass</sub> in milligrams/kN	nvPM <sub>num</sub> in particles/kN
26.7 < rO ≤ 200	4646.9 – 21.497·rO	2.669·10 <sup>16</sup> – 1.126·10 <sup>14</sup> ·rO
rO > 200	347.5	4.170·10 <sup>15</sup>

(c) *HC*. Engines of a type or model for which the date of manufacture of the individual engine is on or after January 1, 1984 may not have a characteristic level for HC exceeding an emission standard of 19.6 g/kN.

(d) *CO*. Engines of a type or model for which the date of manufacture of the individual engine is on or after July 7, 1997 may not have a characteristic level for CO exceeding an emission standard of 118 g/kN.

(e) *NO<sub>x</sub>*. An engine's characteristic level for NO<sub>x</sub> may not exceed emission standards as follows:

(1) *Tier 0*. The following NO<sub>x</sub> emission standards apply to engines of a type or model for which the date of manufacture of the first individual production model was on or before December 31, 1995 and for which the date of manufacture of the individual engine was on or after December 31, 1999 and before December 31, 2003:

$$NO_x + (40 + 2(rPR)) \text{ g/kN}$$

(2) *Tier 2*. The following NO<sub>x</sub> emission standards apply to engines of a type or model for which the date of manufacture of the first individual

production model was after December 31, 1995 or for which the date of manufacture of the individual engine was on or after December 31, 1999 and before December 31, 2003:

$$NO_x + (32 + 1.6(rPR)) \text{ g/kN}$$

(3) *Tier 4 new type*. The following NO<sub>x</sub> emission standards apply to engines of a type or model for which the date of manufacture of the first individual production model was after December 31, 2003 and before July 18, 2012:

TABLE 3 TO § 1031.60(e)(3)—TIER 4 NEW TYPE NO<sub>x</sub> STANDARDS

If the rated pressure ratio (rPR) is—	and the rated output (kN) is—	the NO <sub>x</sub> emission standard (g/kN) is—
(i) rPR ≤ 30	(A) 26.7 < rO ≤ 89	37.572 + 1.6(rPR) – 0.2087(rO)
	(B) rO > 89	19 + 1.6·rPR

TABLE 3 TO § 1031.60(e)(3)—TIER 4 NEW TYPE NO<sub>x</sub> STANDARDS—Continued

If the rated pressure ratio (rPR) is—	and the rated output (kN) is—	the NO <sub>x</sub> emission standard (g/kN) is—
(ii) 30 < rPR < 62.5 .....	(A) 26.7 < rO ≤ 89 .....	42.71 + 1.4286(rPR) – 0.4013(rO) + 0.00642(rPR × rO)
	(B) rO > 89 .....	7 + 2·rPR
(iii) rPR ≥ 82.6 .....	All .....	32 + 1.6·rPR

(4) *Tier 6 in-production.* The following NO<sub>x</sub> emission standards apply to engines of a type or model for which the date of manufacture of the individual engine is on or after July 18, 2012:

TABLE 4 TO § 1031.60(e)(4)—TIER 6 IN-PRODUCTION NO<sub>x</sub> STANDARDS

If the rated pressure ratio (rPR) is—	and the rated output (kN) is—	the NO <sub>x</sub> emission standard (g/kN) is—
(i) rPR ≤ 30 .....	(A) 26.7 < rO ≤ 89 .....	38.5486 + 1.6823·rPR – 0.2453·rO – 0.00308·rPR·rO
	(B) rO > 89 .....	16.72 + 1.4080·rPR
(ii) 30 < rPR < 82.6 .....	(A) 26.7 < rO ≤ 89 .....	46.1600 + 1.4286·rPR – 0.5303·rO + 0.00642·rPR·rO
	(B) rO > 89 .....	– 1.04 + 2.0·rPR
(iii) rPR ≥ 82.6 .....	All .....	32 + 1.6·rPR

(5) *Tier 8 new type.* The following NO<sub>x</sub> standards apply to engines of a type or model for which the date of manufacture of the first individual production model was on or after January 1, 2014; or for which an application for original type certification is submitted on or after January 1, 2023; or for engines covered by an earlier type certificate if they do not qualify as derivative engines for emission purposes as described in § 1031.130:

TABLE 5 TO § 1031.60(e)(5)—TIER 8 NEW TYPE NO<sub>x</sub> STANDARDS

If the rated pressure ratio (rPR) is—	and the rated output (kN) is—	the NO <sub>x</sub> emission standard (g/kN) is—
(i) rPR ≤ 30 .....	(A) 26.7 < rO ≤ 89 .....	40.052 + 1.5681·rPR – 0.3615·rO – 0.0018·rPR·rO
	(B) rO > 89 .....	7.88 + 1.4080·rPR
(ii) 30 < rPR < 104.7 .....	(A) 26.7 < rO ≤ 89 .....	41.9435 + 1.505·rPR – 0.5823·rO + 0.005562·rPR·rO
	(B) rO > 89 .....	– 9.88 + 2.0·rPR
(iii) rPR ≥ 104.7 .....	All .....	32 + 1.6·rPR

**§ 1031.90 Supersonic engines.**

The following standards apply to new engines installed in supersonic airplanes:

(a) *Smoke.* (1) Engines of a type or model for which the date of manufacture was on or after January 1, 1984, may not have a characteristic level for smoke number exceeding an emission standard that is the lesser of 50 or the following:

$$SN = 83.6 \cdot rO - 0.274$$

(2) [Reserved]

(b) [Reserved]

(c) *HC.* Engines of a type or model for which the date of manufacture was on or after January 1, 1984, may not have a characteristic level for HC exceeding the following emission standard in g/kN rated output:

$$HC = 140 \cdot 0.92rPR$$

(d) *CO.* Engines of a type or model for which the date of manufacture was on or after July 18, 2012, may not have a characteristic level for CO exceeding the following emission standard in g/kN rated output:

$$CO = 4550 \cdot rPR - 1.03$$

(e) *NO<sub>x</sub>.* Engines of a type or model for which the date of manufacture was on or after July 18, 2012, may not have a characteristic level for NO<sub>x</sub> engines exceeding the following emission standard in g/kN rated output:

$$NO_x = 36 + 2.42 \cdot rPR$$

**§ 1031.130 Derivative engines for emissions certification purposes.**

(a) *Overview.* FAA may approve a type certificate holder's request for an engine configuration to be considered a derivative engine for emission purposes under this part if the type certificate holder demonstrates the engine configuration is similar in design to a previously certificated (original) engine for purposes of compliance with exhaust emission standards and at least one of the following circumstances applies:

(1) The FAA determines that a safety issue requires an engine modification.

(2) All regulated emissions from the proposed derivative engine are lower

than the corresponding emissions from the previously certificated engine.

(3) The FAA determines that the proposed derivative engine's emissions are similar to the previously certificated engine's emissions as described in paragraph (c) of this section.

(b) *Determining emission rates.* To determine new emission rates for a derivative engine for demonstrating compliance with emission standards under § 1031.30(a)(4) and for showing emissions similarity in paragraph (c) of this section, testing may not be required in all situations. If the previously certificated engine model or any associated sub-models have a characteristic level before modification that is at or above 95% of any applicable standard for smoke number, HC, CO, or NO<sub>x</sub> or at or above 80% of any applicable nvPM standard, you must test the proposed derivative engine. Otherwise, you may use engineering analysis to determine the new emission rates, consistent with good engineering judgment. The engineering analysis must address all modifications from the

previously certificated engine, including those approved for previous derivative engines.

(c) *Emissions similarity.* (1) A proposed derivative engine's emissions are similar to the previously certificated engine's emissions if the type certificate holder demonstrates that the engine meets the applicable emission standards and differ from the previously certificated engine's emissions only within the following ranges:

- (i) ±3.0 g/kN for NO<sub>x</sub>.
- (ii) ±1.0 g/kN for HC.
- (iii) ±5.0 g/kN for CO.
- (iv) ±2.0 SN for smoke number.
- (v) The following values apply for nvPM<sub>MC</sub>:

(A) ±200 µg/m<sup>3</sup> if the characteristic level of maximum nvPM<sub>MC</sub> is below 1,000 µg/m<sup>3</sup>.

(B) ±20% of the characteristic level if the characteristic level for maximum nvPM<sub>MC</sub> is at or above 1,000 µg/m<sup>3</sup>.

(vi) The following values apply for nvPM<sub>mass</sub>:

(A) 80 mg/kN if the characteristic level for nvPM<sub>mass</sub> emissions is below 400 mg/kN.

(B) ±20% of the characteristic level if the characteristic level for nvPM<sub>mass</sub> emissions is greater than or equal to 400 mg/kN.

(vii) The following values apply for nvPM<sub>num</sub>:

(A) 4 × 10<sup>14</sup> particles/kN if the characteristic level for nvPM<sub>num</sub> emissions is below 2 × 10<sup>15</sup> particles/kN.

(B) ±20% of the characteristic level if the characteristic level for nvPM<sub>num</sub> emissions is greater than or equal to 2 × 10<sup>15</sup> particles/kN.

(2) In unusual circumstances, the FAA may adjust the ranges specified in paragraph (c)(1) of this section to evaluate a proposed derivative engine, after consulting with the EPA.

**§ 1031.140 Test procedures.**

(a) *Overview.* Measure emissions using the equipment, procedures, and test fuel specified in Appendices 1 through 8 of ICAO Annex 16 (incorporated by reference, see § 1031.210) as described in this section (referenced in this section as "ICAO Appendix #"). For turboprop engines, use the procedures specified in ICAO Annex 16 for turbofan engines, consistent with good engineering judgment.

(b) *Test fuel specifications.* Use a test fuel meeting the specifications described in ICAO Appendix 4. The test fuel must not have additives whose purpose is to suppress smoke, such as organometallic compounds.

(c) *Test conditions.* Prepare test engines by including accessories that

are available with production engines if they can reasonably be expected to influence emissions.

(1) The test engine may not extract shaft power or bleed service air to provide power to auxiliary gearbox-mounted components required to drive aircraft systems.

(2) Test engines must reach a steady operating temperature before the start of emission measurements.

(d) *Alternate procedures.* In consultation with the EPA, the FAA may approve alternate procedures for measuring emissions. This might include testing and sampling methods, analytical techniques, and equipment specifications that differ from those specified in this part. An applicant for type certification may request this approval by sending a written request with supporting justification to the FAA and to the Designated EPA Program Officer. Such a request may be approved only in the following circumstances:

(1) The engine cannot be tested using the specified procedures.

(2) The alternate procedure is shown to be equivalent to or better (e.g., more accurate or precise) than the specified procedure.

(e) *LTO cycles.* The following landing and take-off (LTO) cycles apply for emission testing and calculating weighted LTO values:

TABLE 1 TO § 1031.140(E)—LTO TEST CYCLES

Mode	Subsonic				Supersonic	
	Turboprop		Turbojet and turbofan		Percent of rO	Time in mode (minutes)
	Percent of rO	Time in mode (minutes)	Percent of rO	Time in mode (minutes)		
Take-off .....	100	0.5	100	0.7	100	1.2
Climb .....	90	2.5	85	2.2	65	2.0
Descent .....	NA	NA	NA	NA	15	1.2
Approach .....	30	4.5	30	4.0	34	2.3
Taxi/ground idle .....	7	26.0	7	26.0	5.8	26.0

(f) *Pollutant-specific test provisions.* Use the following provisions to demonstrate whether engines meet the applicable standards:

(1) *Smoke number.* Use the equipment and procedures specified in ICAO Appendix 2 and ICAO Appendix 6. Test the engine at sufficient thrust settings to determine and compute the maximum smoke number.

(2) *nvPM.* Use the equipment and procedures specified in ICAO Appendix 7 and ICAO Appendix 6, as applicable:

(i) *Maximum nvPM mass concentration.* Test the engine at sufficient thrust settings to determine and compute the maximum nvPM mass concentration produced by the engine at

any thrust setting, according to the procedures of ICAO Appendix 7.

(ii) *LTO nvPM mass and number.* Test the engine at sufficient thrust settings to determine the engine's nvPM mass and nvPM number at the rated output identified in table 1 to paragraph (e) of this section.

(3) *HC, CO, and NO<sub>x</sub>.* Use the equipment and procedures specified in ICAO Appendix 3, ICAO Appendix 5, and ICAO Appendix 6, as applicable. Test the engine at sufficient thrust settings to determine the engine's HC, CO, and NO<sub>x</sub> emissions at the rated output identified in table 1 to paragraph (e) of this section.

(4) *CO<sub>2</sub>.* Calculate CO<sub>2</sub> emission values from fuel mass flow rate measurements in ICAO Appendix 3 and ICAO Appendix 5 or, alternatively, according to the CO<sub>2</sub> measurement criteria in ICAO Appendix 3 and ICAO Appendix 5.

(g) *Characteristic level.* The compliance demonstration consists of establishing a mean value from testing some number of engines, then calculating a "characteristic level" by applying a set of statistical factors in ICAO Appendix 6 that take into account the number of engines tested. Round each characteristic level to the same number of decimal places as the corresponding standard. Engines

comply with an applicable standard if the testing results show that the engine type certificate family's characteristic level does not exceed the numerical level of that standard.

(h) *System loss corrected nvPM emission indices.* Use the equipment and procedures specified in ICAO Appendix 8, as applicable, to determine system loss corrected nvPM emission indices.

### Subpart C—Reporting and Recordkeeping

#### § 1031.150 Production reports.

Engine manufacturers must submit an annual production report for each calendar year in which they produce any engines subject to emission standards under this part.

(a) The report is due by February 28 of the following calendar year. Include emission data in the report as described in paragraph (c) of this section. If you produce exempted or excepted engines, submit a single report with information on exempted/excepted and normally certificated engines.

(b) Send the report to the Designated EPA Program Officer.

(c) In the report, specify your corporate name and the year for which you are reporting. Include information as described in this section for each engine sub-model subject to emission standards under this part. List each engine sub-model manufactured or certificated during the calendar year, including the following information for each sub-model:

- (1) The type of engine (turbofan, turboprop, etc.) and complete sub-model name, including any applicable model name, sub-model identifier, and engine type certificate family identifier.
- (2) The certificate under which it was manufactured. Identify all the following:
  - (i) The type certificate number. Specify if the sub-model also has a type certificate issued by a certifying authority other than FAA.
  - (ii) Your corporate name as listed in the certificate.
  - (iii) Emission standards to which the engine is certificated.
  - (iv) Date of issue of type certificate (month and year).
  - (v) Whether or not this is a derivative engine for emissions certification purposes. If so, identify the previously certificated engine model.
  - (vi) The engine sub-model that received the original type certificate for an engine type certificate family.
- (3) Identify the combustor of the sub-model, where more than one type of combustor is available.
- (4) The calendar-year production volume of engines from the sub-model

that are covered by an FAA type certificate. Record zero for sub-models with no engines manufactured during the calendar year, or state that the engine model is no longer in production and list the date of manufacture (month and year) of the last engine manufactured. Specify the number of these engines that are intended for use on new aircraft and the number that are intended for use as non-exempt engines on in-use aircraft. For engines delivered without a final sub-model status and for which the manufacturer has not ascertained the engine's sub-model when installed before submitting its production report, the manufacturer may do any of the following in its initial report, and amend it later:

- (i) List the sub-model that was shipped or the most probable sub-model.
- (ii) List all potential sub-models.
- (iii) State "Unknown Sub-Model."
- (5) The number of engines tested and the number of test runs for the applicable type certificate.
- (6) Test data and related information required to certify the engine sub-model for all the standards that apply. Round reported values to the same number of decimal places as the standard. Include the following information, as applicable:

- (i) The engine's rated pressure ratio and rated output.
- (ii) The following values for each mode of the LTO test cycle:
  - (A) Fuel mass flow rate.
  - (B) Smoke number.
  - (C) nvPM mass concentration.
  - (D) mass of CO<sub>2</sub>
  - (E) Emission Indices for HC, CO, NO<sub>x</sub>, and CO<sub>2</sub>.
- (F) The following values related to nvPM mass and nvPM number:
  - (1) Emission Indices as measured.
  - (2) System loss correction factor.
  - (3) Emissions Indices after correcting for system losses.
  - (iii) Weighted total values calculated from the tested LTO cycle modes for HC, CO, NO<sub>x</sub>, CO<sub>2</sub>, and nvPM mass and nvPM number. Include nvPM mass and nvPM number values with and without system loss correction.
  - (iv) The characteristic level for HC, CO, NO<sub>x</sub>, smoke number, nvPM mass concentration, nvPM mass, and nvPM number.
  - (v) The following maximum values:
    - (A) Smoke number.
    - (B) nvPM mass concentration.
    - (C) nvPM mass Emission Index with and without system loss correction.
    - (D) nvPM number Emission Index with and without system loss correction.
  - (d) Identify the number of exempted or excepted engines with a date of

manufacture during the calendar year, along with the engine model and sub-model names of each engine, the type of exemption or exception, and the use of each engine (for example, spare or new installation). For purposes of this paragraph (d), treat spare engine exceptions separate from other new engine exemptions.

(e) Include the following signed statement and endorsement by an authorized representative of your company: "We submit this report under 40 CFR 1031.150. All the information in this report is true and accurate to the best of my knowledge."

(f) Where information provided for the previous annual report remains valid and complete, you may report your production volumes and state that there are no changes, without resubmitting the other information specified in this section.

#### § 1031.160 Recordkeeping.

(a) You must keep a copy of any reports or other information you submit to us for at least three years.

(b) Store these records in any format and on any media, as long as you can promptly send us organized, written records in English if we ask for them. You must keep these records readily available. We may review them at any time.

#### § 1031.170 Confidential business information.

The provisions of 40 CFR 1068.10 apply for information you consider confidential.

### Subpart D—Reference Information

#### § 1031.200 Abbreviations.

The abbreviations used in this part have the following meanings:

°	Degree
%	Percent
CO	carbon monoxide
CO <sub>2</sub>	carbon dioxide
EI	emission index
G	Gram
HC	hydrocarbon(s)
Kg	Kilogram
kN	Kilonewton
kW	Kilowatt
LTO	landing and takeoff
M	Meter
Mg	Milligram
µg	microgram
NO <sub>x</sub>	oxides of nitrogen
Num	number
nvPM	nonvolatile particulate matter
nvPM <sub>mass</sub>	nonvolatile particulate matter mass
nvPM <sub>num</sub>	nonvolatile particulate matter number
nvPM <sub>MC</sub>	nonvolatile particulate matter mass concentration

rO rated output  
rPR rated pressure ratio  
SN smoke number

#### § 1031.205 Definitions.

The following definitions apply to this part. Any terms not defined in this section have the meaning given in the Clean Air Act (42 U.S.C. 7401–7671q). The definitions follow:

*Aircraft* has the meaning given in 14 CFR 1.1, a device that is used or intended to be used for flight in the air.

*Aircraft engine* means a propulsion engine that is installed on or that is manufactured for installation on an airplane for which certification under 14 CFR is sought.

*Aircraft gas turbine engine* means a turboprop, turbojet, or turbofan aircraft engine.

*Airplane* has the meaning given in 14 CFR 1.1, an engine-driven fixed-wing aircraft heavier than air, that is supported in flight by the dynamic reaction of the air against its wings.

*Characteristic level* has the meaning given in Appendix 6 of ICAO Annex 16 (incorporated by reference, see § 1031.210). The characteristic level is a calculated emission level for each pollutant based on a statistical assessment of measured emissions from multiple tests.

*Date of manufacture* means the date on which a manufacturer is issued documentation by FAA (or other recognized airworthiness authority for engines certificated outside the United States) attesting that the given engine conforms to all applicable requirements. This date may not be earlier than the date on which engine assembly is complete. Where the manufacturer does not obtain such documentation from FAA (or other recognized airworthiness authority for engines certificated outside the United States), date of manufacture means the date of final engine assembly.

*Derivative engine for emissions certification purposes* means an engine that has the same or similar emissions characteristics as an engine covered by a U.S. type certificate issued under 14 CFR part 33. These characteristics are specified in § 1031.130.

*Designated EPA Program Officer* means the Director of the Assessment and Standards Division, 2000 Traverwood Drive, Ann Arbor, Michigan 48105.

*Emission index* means the quantity of pollutant emitted per unit of fuel mass used.

*Engine model* means an engine manufacturer's designation for an engine grouping of engines and/or engine sub-models within a single engine type certificate family, where

such engines have similar design, including being similar with respect to the core engine and combustor designs.

*Engine sub-model* means a designation for a grouping of engines with essentially identical design, especially with respect to the core engine and combustor designs and other emission-related features. Engines from an engine sub-model must be contained within a single engine model. For purposes of this part, an original engine model configuration is considered a sub-model. For example, if a manufacturer initially produces an engine model designated ABC and later introduces a new sub-model ABC–1, the engine model consists of two sub-models: ABC and ABC–1.

*Engine type certificate family* means a group of engines (comprising one or more engine models, including sub-models and derivative engines for emissions certification purposes of those engine models) determined by FAA to have a sufficiently common design to be grouped together under a type certificate.

*EPA* means the U.S. Environmental Protection Agency.

*Except* means to routinely allow engines to be manufactured and sold that do not meet (or do not fully meet) otherwise applicable standards. Note that this definition applies only with respect to § 1031.11 and that the term “except” has its plain meaning in other contexts.

*Exempt* means to allow, through a formal case-by-case process, an engine to be certificated and sold that does not meet the applicable standards of this part.

*Exhaust emissions* means substances emitted to the atmosphere from exhaust discharge nozzles, as measured by the test procedures specified in § 1031.140.

*FAA* means the U.S. Department of Transportation, Federal Aviation Administration.

*Good engineering judgment* involves making decisions consistent with generally accepted scientific and engineering principles and all relevant information, subject to the provisions of 40 CFR 1068.5.

*ICAO Annex 16* means Volume II of Annex 16 to the Convention on International Civil Aviation (see § 1031.210 for availability).

*New* means relating to an aircraft or aircraft engine that has never been placed into service.

*Non-volatile particulate matter (nvPM)* means emitted particles that exist at a gas turbine engine exhaust nozzle exit plane that do not volatilize when heated to a temperature of 350 °C.

*Rated output (rO)* means the maximum power or thrust available for takeoff at standard day conditions as approved for the engine by FAA, including reheat contribution where applicable, but excluding any contribution due to water injection. Rated output is expressed in kilowatts for turboprop engines and in kilonewtons for turbojet and turbofan engines to at least three significant figures.

*Rated pressure ratio (rPR)* means the ratio between the combustor inlet pressure and the engine inlet pressure achieved by an engine operating at rated output, expressed to at least three significant figures.

*Round* has the meaning given in 40 CFR 1065.1001.

*Smoke* means the matter in exhaust emissions that obscures the transmission of light, as measured by the test procedures specified in § 1031.140.

*Smoke number* means a dimensionless value quantifying smoke emissions as calculated according to ICAO Annex 16.

*Spare engine* means an engine installed (or intended to be installed) on an in-use aircraft to replace an existing engine. See § 1031.11.

*Standard day conditions* means the following ambient conditions: Temperature = 15 °C, specific humidity = 0.00634 kg H<sub>2</sub>O/kg dry air, and pressure = 101.325 kPa.

*Subsonic* means relating to an aircraft that has not been certificated under 14 CFR to exceed Mach 1 in normal operation.

*Supersonic airplane* means an airplane for which the maximum operating limit speed exceeds a Mach number of 1.

*System losses* means the loss of particles during transport through a sampling or measurement system component or due to instrument performance. Sampling and measurement system loss is due to various deposition mechanisms, some of which are particle-size dependent. Determining an engine's actual emission rate depends on correcting for system losses in the nvPM measurement.

*Turbofan engine* means a gas turbine engine designed to create its propulsion from exhaust gases and from air that bypasses the combustion process and is accelerated in a ducted space between the inner (core) engine case and the outer engine fan casing.

*Turbojet engine* means a gas turbine engine that is designed to create its propulsion entirely from exhaust gases.

*Turboprop engine* means a gas turbine engine that is designed to create most of



its propulsion from a propeller driven by a turbine, usually through a gearbox.

*Turboshaft engine* means a gas turbine engine that is designed to drive a rotor transmission system or a gas turbine engine not used for propulsion.

*We (us, our)* means the EPA Administrator and any authorized representatives.

**§ 1031.210 Incorporation by reference.**

(a) Certain material is incorporated by reference into this part with the approval of the Director of the Federal Register under 5 U.S.C. 552(a) and 1 CFR part 51. To enforce any edition other than that specified in this section, the Environmental Protection Agency

must publish a document in the **Federal Register** and the material must be available to the public. All approved material is available for inspection at U.S. EPA, Air and Radiation Docket Center, WJC West Building, Room 3334, 1301 Constitution Ave NW, Washington, DC 20004, [www.epa.gov/dockets](http://www.epa.gov/dockets), (202) 202-1744, and is available from the sources listed in this section. It is also available for inspection at the National Archives and Records Administration (NARA). For information on the availability of this material at NARA, email [fr.inspection@nara.gov](mailto:fr.inspection@nara.gov) or go to [www.archives.gov/federal-register/cfr/ibr-locations.html](http://www.archives.gov/federal-register/cfr/ibr-locations.html).

(b) International Civil Aviation Organization, Document Sales Unit, 999 University Street, Montreal, Quebec, Canada H3C 5H7, (514) 954-8022, [www.icao.int](http://www.icao.int), or [sales@icao.int](mailto:sales@icao.int).

(1) Annex 16 to the Convention on International Civil Aviation, Environmental Protection, as follows:

(i) Volume II—Aircraft Engine Emissions, Fourth Edition, July 2017, Including Amendment 10 of January 1, 2021 (as indicated in footnoted pages). IBR approved for §§ 1031.140 and 1031.205.

(ii) [Reserved]

(2) [Reserved]

[FR Doc. 2022-01150 Filed 2-2-22; 8:45 am]

**BILLING CODE 6560-50-P**



# FEDERAL REGISTER

---

Vol. 87

Thursday,

No. 23

February 3, 2022

---

Part IV

## Department of Housing and Urban Development

---

Allocations for Community Development Block Grant Disaster Recovery and Implementation of the CDBG-DR Consolidated Waivers and Alternative Requirements Notice; Notice

**DEPARTMENT OF HOUSING AND URBAN DEVELOPMENT**

[Docket No. FR-6303-N-01]

**Allocations for Community Development Block Grant Disaster Recovery and Implementation of the CDBG-DR Consolidated Waivers and Alternative Requirements Notice**

**AGENCY:** Office of the Assistant Secretary for Community Planning and Development, HUD.

**ACTION:** Notice.

**SUMMARY:** On October 29, 2021, HUD allocated over \$2 billion in Community Development Block Grant Disaster Recovery (CDBG-DR) funds appropriated by the Disaster Relief Supplemental Appropriations Act, 2022. This Allocation Announcement Notice imposes HUD’s *CDBG-DR Consolidated Notice* (“Consolidated Notice”) (Appendix B) and any amendments to the Consolidated Notice only on CDBG-DR grants for disasters occurring in 2020, as identified herein. The Consolidated Notice, as amended by this Allocation Announcement Notice, includes waivers and alternative requirements, relevant regulatory requirements, the grant award process, criteria for action plan approval, and eligible disaster recovery activities.

**DATES:** *Applicability Date:* February 8, 2022.

**FOR FURTHER INFORMATION CONTACT:** Jessie Handforth Kome, Director, Office of Block Grant Assistance, Department of Housing and Urban Development, 451 7th Street SW, Room 10166, Washington, DC 20410, telephone number 202-708-3587. Persons with hearing or speech impairments may access this number via TTY by calling the Federal Relay Service at 800-877-8339. Facsimile inquiries may be sent to Ms. Kome at 202-708-0033. (Except for the “800” number, these telephone numbers are not toll-free). Email

inquiries may be sent to [disaster\\_recovery@hud.gov](mailto:disaster_recovery@hud.gov).

**SUPPLEMENTARY INFORMATION:**

**Table of Contents**

- I. Allocations
- II. Use of Funds
- III. Overview of Grant Process
  - A. Requirements Related to Administrative Funds
- IV. Applicable Rules, Statutes, Waivers, and Alternative Requirements
  - A. Grant Administration
- V. Duration of Funding
- VI. Catalog of Federal Domestic Assistance
- VII. Finding of No Significant Impact
- Appendix A: Allocation Methodology
- Appendix B: CDBG-DR Consolidated Notice

**I. Allocations**

The Disaster Relief Supplemental Appropriations Act, 2022 (Pub. L. 117-43) approved September 30, 2021 (the “Appropriations Act”) makes available \$5,000,000,000 in Community Development Block Grant Disaster Recovery (CDBG-DR) funds. These CDBG-DR funds are for necessary expenses for activities authorized under title I of the Housing and Community Development Act of 1974 (42 U.S.C. 5301 *et seq.*) (HCDA) related to disaster relief, long-term recovery, restoration of infrastructure and housing, economic revitalization, and mitigation in the “most impacted and distressed” (MID) areas resulting from a qualifying major disaster in 2020 or 2021. HUD allocated over \$2 billion in CDBG-DR funds from the Appropriations Act to assist in long-term recovery from disasters occurring in 2020. The Appropriations Act requires HUD to include with any final allocation for the total estimate of unmet need an additional amount of 15 percent of that estimate for mitigation activities that reduce risk in the MID areas (see Table 1).

In accordance with the Appropriations Act, \$5,500,000 of the total amounts appropriated under the Act will be transferred to the Department’s Office of Community Planning and Development (CPD),

Program Office Salaries and Expenses, for necessary costs of administering and overseeing CDBG-DR funds, including information technology costs. Additionally, in accordance with the Appropriations Act, up to \$7,000,000 shall be made available for capacity building and technical assistance, including assistance on contracting and procurement, to support existing and future CDBG-DR grantees and their subrecipients. HUD will allocate the remaining funds appropriated for CDBG-DR grants from the Appropriations Act when HUD receives the best available data for major disasters occurring in 2020 or 2021.

The Appropriations Act provides that grants shall be awarded directly to a state, local government, or Indian tribe at the discretion of the Secretary.

Pursuant to the Appropriations Act, HUD has identified the MID areas based on the best available data for all eligible affected areas. A detailed explanation of HUD’s allocation methodology is provided in Appendix A of this notice. At least 80 percent of all allocations provided to each grantee must address unmet disaster needs or mitigation activities in the HUD-identified MID areas, as identified in the last column of Table 2. Each grantee may determine where to use the remaining 20 percent of their allocation, but that portion of the allocation may only be used to address unmet disaster needs or mitigation activities in those areas that the grantee determines are “most impacted and distressed” and that received a presidential major disaster declaration identified by the FEMA disaster numbers listed in column one of Table 1. Detailed requirements around MID areas are provided in section II.A.3. of the Consolidated Notice.

Based on further review of the impacts from the eligible disasters, and estimates of unmet need, HUD is making the following allocations:

**TABLE 1—ALLOCATIONS FOR UNMET NEEDS AND MITIGATION ACTIVITIES UNDER PUBLIC LAW 117-43 FOR DISASTERS OCCURRING IN 2020**

FEMA Disaster No.	State	Grantee	Allocation for unmet needs under this notice from Public Law 117-43	CDBG-DR mitigation set-aside amounts from Public Law 117-43	Total allocated under this notice from Public Law 117-43
4563, 4573 .....	Alabama .....	State of Alabama .....	\$271,071,000	\$40,661,000	\$311,732,000
4558, 4569 .....	California .....	State of California .....	201,046,000	30,157,000	231,203,000
4564 .....	Florida .....	State of Florida .....	98,427,000	14,764,000	113,191,000
4557 .....	Iowa .....	State of Iowa .....	49,513,000	7,427,000	56,940,000
4559, 4570 .....	Louisiana .....	State of Louisiana .....	521,853,000	78,278,000	600,131,000
4547 .....	Michigan .....	State of Michigan .....	52,085,000	7,813,000	59,898,000
4576 .....	Mississippi .....	State of Mississippi .....	24,757,000	3,713,000	28,470,000
4562 .....	Oregon .....	State of Oregon .....	367,205,000	55,081,000	422,286,000
4473, 4560 .....	Puerto Rico .....	Commonwealth of Puerto Rico .....	* 155,794,000	28,832,000	184,626,000
4476, 4541 .....	Tennessee .....	State of Tennessee .....	37,165,000	5,575,000	42,740,000

TABLE 1—ALLOCATIONS FOR UNMET NEEDS AND MITIGATION ACTIVITIES UNDER PUBLIC LAW 117–43 FOR DISASTERS OCCURRING IN 2020—Continued

FEMA Disaster No.	State	Grantee	Allocation for unmet needs under this notice from Public Law 117–43	CDBG–DR mitigation set-aside amounts from Public Law 117–43	Total allocated under this notice from Public Law 117–43
Totals .....	.....	.....	1,778,916,000	272,301,000	2,051,217,000

\* Puerto Rico was allocated \$36,424,000 from Public Law 116–20 (see 86 FR 569) for unmet needs related to one of the qualifying disasters listed in the first column (FEMA disaster no. 4473). The grantee’s CDBG mitigation set-aside in the fifth column was calculated as 15 percent of the total estimate for unmet needs allocated for this disaster (which includes the portions of unmet need funded by Public Law 116–20 and by Public Law 117–43). The grantee’s final allocation in the sixth column represents the total estimate for unmet needs for Puerto Rico’s qualifying disasters under Public Law 117–43, including the additional amount for the CDBG mitigation set-aside.

TABLE 2—MOST IMPACTED AND DISTRESSED AREAS FOR DISASTERS OCCURRING IN 2020

Grantee	Minimum amount under this notice from Public Law 117–43 that must be expended in the HUD-identified “most impacted and distressed” areas listed herein	“Most Impacted and Distressed” areas
State of Alabama	\$249,385,600	Baldwin and Mobile Counties; 36502 (Escambia County).
State of California	184,962,400	Butte, Napa, Santa Cruz, Los Angeles, and Siskiyou Counties; 95448 (Sonoma County), 95688 (Solano County), 93602 (Fresno County), 93664 (Fresno County), 94558 (Napa County), 94574 (Napa County), 95404 (Sonoma County), 95409 (Sonoma County), and 96047 (Shasta County).
State of Florida ....	90,552,800	Escambia County; 32583 (Santa Rosa County).
State of Iowa .....	45,552,000	Linn County.
State of Louisiana	480,104,800	Beauregard Parish, Caddo Parish, Calcasieu Parish, Cameron Parish, Ouachita Parish, Rapides Parish and Calcasieu Parish; 70546 (Jefferson Davis Parish), 70570 (St. Landry Parish), 71446 (Vernon Parish), 71457 (Natchitoches Parish), 71463 (Allen Parish), 70501 (Lafayette Parish), 70510 (Vermillion Parish), 70526 (Acadia Parish), 70546 (Jefferson Davis Parish), 70570 (St. Landry Parish), 70578 (Acadia Parish), 71302 (Rapides Parish), and 71463 (Allen Parish).
State of Michigan	47,918,400	Midland and Saginaw Counties; 48612 (Gladwin County).
State of Mississippi	22,776,000	Harrison County.
State of Oregon ...	337,828,800	Clackamas, Douglas, Jackson, Lane, Lincoln, and Marion Counties; 97358 (Linn County).
Commonwealth of Puerto Rico	147,700,800	Guanica, Ponce, and Yauco; 00624 (Penuelas Municipio), 00656 (Guayanilla Municipio), 00667 (Lajas Municipio), and 00680 (Mayaguez Municipio).
State of Tennessee	34,192,000	37208 (Davidson County), 38501 (Putnam County), and 37421 (Hamilton County).

**II. Use of Funds**

Unless otherwise indicated, funds allocated under this notice from Public Law 117–43 are subject to the requirements of this Allocation Announcement Notice and the Consolidated Notice, included as Appendix B, as amended by this Allocation Announcement Notice. This Allocation Announcement Notice outlines additional requirements imposed by the Appropriations Act that apply only to funds allocated under this notice.

The Appropriations Act requires that prior to the obligation of CDBG–DR funds by the Secretary, a grantee shall submit a plan to HUD for approval detailing the use of funds. The plan must include the criteria for eligibility, and how the use of these funds will address long-term recovery and restoration of infrastructure and housing, economic revitalization, and mitigation in the MID areas. This notice requires the grantee to submit an action plan that addresses unmet recovery needs and mitigation activities related to the disasters identified in Table 1.

Therefore, the action plan submitted in response to this notice must describe uses and activities that: (1) Are authorized under title I of the HCDA or allowed by a waiver or alternative requirement; and (2) respond to disaster-related impacts to infrastructure, housing, economic revitalization, and mitigation in the MID areas. Requirements related to action plans are provided in section III.C. of the Consolidated Notice.

In accordance with the Appropriations Act, grantees must spend 15 percent of the amount of each grant, as outlined in Table 1, for mitigation activities as described in section IV.A.2. of this notice. Grantees must also incorporate mitigation measures into its recovery activities as required under section II.A.2. in the Consolidated Notice. Grantees must conduct an assessment of community impacts and unmet needs to inform the plan and guide the development and prioritization of planned recovery activities, pursuant to section III.C.1.a. of the Consolidated Notice. Additionally, with regard to the 15

percent of funds provided for mitigation activities, grantees must also prepare a mitigation needs assessment to inform their mitigation activities, as described in section IV.A.2.a. of this notice.

To comply with the statutory requirement in the Appropriations Act, grantees shall not use CDBG–DR funds for activities reimbursable by or for which funds are made available by the Federal Emergency Management Agency (FEMA) or the U.S. Army Corps of Engineers (USACE). Grantees must verify whether FEMA or USACE funds are available prior to awarding CDBG–DR funds to specific activities or beneficiaries. Grantees may use CDBG–DR funds as the non-Federal match as described in section II.C.3. of the Consolidated Notice.

**III. Overview of Grant Process**

*A. Requirements Related to Administrative Funds*

III.A.1. *Action plan submittal for program administrative costs.* The Appropriations Act allows grantees receiving an award under this notice to access funding for program

administrative costs prior to the Secretary's certification of financial controls and procurement processes, and adequate procedures for proper grant management. To implement this authority, the following alternative requirement will replace the alternative requirement in the Consolidated Notice at III.C.1.

If a grantee chooses to access funds for program administrative costs prior to the Secretary's certification, it must first prepare an action plan describing its use of funds for program administrative costs, subject to the five percent cap on the use of grant funds for such costs. Instead of following requirements in section III.C.1. of the Consolidated Notice, which require grantees to use the Public Action Plan in HUD's Disaster Recovery Grant Reporting (DRGR) system to submit their action plans, grantees will follow a different process to access funds for program administrative costs prior to the Secretary's certification.

As part of the process of accessing funds for these costs, grantees must submit to HUD an action plan describing their use of funds for program administrative costs. The action plan will be developed outside of DRGR and must include all proposed uses of funds for program administrative costs incurred prior to a final action plan being submitted and approved. The action plan for program administrative costs must also include the criteria for eligibility and the amount to be budgeted for that activity. If a grantee chooses to submit the action plan for program administrative costs, the grantee should calculate its need to cover program administrative costs over the life of the grant and consider how much of its available program administrative funds may be reasonably budgeted at this very early stage of its grant lifecycle.

**III.A.1.a. Publication of the action plan for program administrative costs and opportunity for public comment.** The grantee must publish the proposed action plan for program administrative costs, and substantial amendments to the plan, for public comment. To permit a more streamlined process and ensure that grants for program administrative costs are awarded in a timely manner in order to allow grantees to more rapidly design and launch recovery activities, provisions of 42 U.S.C. 5304(a)(2) and (3), 42 U.S.C. 12707, 24 CFR 570.486, 24 CFR 1003.604, 24 CFR 91.105(b) through (d), and 24 CFR 91.115(b) through (d), with respect to citizen participation requirements, are waived and replaced by the alternative requirements in section III.A.1. that

apply only to action plans for program administrative costs and substantial amendments to these plans.

Additionally, for these action plans only, grantees are not subject to the Consolidated Notice action plan requirements in sections III.B.2.i., III.C.2., III.C.3., III.C.6., and III.D.1.a.–c.

The manner of publication of the action plan for program administrative costs must include prominent posting on the grantee's official disaster recovery website and must afford residents, affected local governments, and other interested parties a reasonable opportunity to review the contents of the plan or substantial amendment. Subsequent to publication of the action plan or substantial amendment to that plan, the grantee must provide a reasonable time frame (no less than seven days) and multiple methods (including electronic submission) for receiving comments on the action plan or substantial amendment for program administrative costs. At a minimum, the topic of disaster recovery on the grantee's website, including the posted action plan or substantial amendment, must be navigable by interested parties from the grantee homepage and must link to the disaster recovery website as required by section III.D.1.e. of the Consolidated Notice. The grantee's records must demonstrate that it has notified affected parties through electronic mailings, press releases, statements by public officials, media advertisements, public service announcements, and/or contacts with neighborhood organizations. Grantees are not required to hold any public hearings on the proposed action plan or substantial amendment for program administrative costs.

The grantee must consider all oral and written comments on the action plan or any substantial amendment. Any updates or changes made to the action plan in response to public comments should be clearly identified in the action plan. A summary of comments on the plan or amendment, and the grantee's response to each, must be included with the action plan or substantial amendment. Grantee responses shall address the substance of the comment rather than merely acknowledge that the comment was received.

After the grantee responds to public comments, it will then submit its action plan or substantial amendment for program administrative costs (which includes Standard Form 424 (SF-424)) to HUD for approval, there is no due date for this plan as it may be submitted any time prior to the grantee's Public Action Plan. HUD will review the action

plan or substantial amendment for program administrative costs within 15 days from date of receipt and determine whether to approve the action plan or substantial amendment to that plan per the criteria identified in this notice.

**III.A.1.b. Certifications waiver and alternative requirement.** Sections 104(b)(4), (c), and (m) of the HCDA (42 U.S.C. 5304(b)(4), (c) & (m)), sections 106(d)(2)(C) & (D) of the HCDA (42 U.S.C. 5306(d)(2)(C) & (D)), and section 106 of the Cranston-Gonzalez National Affordable Housing Act (42 U.S.C. 12706), and regulations at 24 CFR 91.225 and 91.325 are waived and replaced with the following alternative. Each grantee choosing to submit an action plan for program administrative costs must make the following certifications listed in section III.F.7. of the Consolidated Notice and include them with the submission of this plan: Paragraphs b., c., d., g., i., j., k., l., p., and q. Additionally, HUD is waiving section 104 and section 106 of the HCDA and section 210 of the Uniform Relocation Assistance and Real Property Acquisition Policies Act of 1970 (42 U.S.C. 4630) only to the extent necessary to allow grantees to receive a portion of their allocation as a grant for program administrative costs before submitting other statutorily required certifications. Each grantee must make all certifications included in section III.F.7. of the Consolidated Notice and submit them to HUD when it submits its Public Action Plan in DRGR described in III.C.1.

**III.A.1.c. Submission of the action plan for program administrative costs in DRGR.** After HUD's approval of the action plan for program administrative costs, the grantee enters the activities from its approved action plan into the DRGR system if it has not previously done so and submits its DRGR action plan to HUD (funds can be drawn from the line of credit only for activities that are established in the DRGR system). HUD will provide additional guidance ("Fact Sheet") with screenshots and step-by-step instructions describing the submittal process for this DRGR action plan for program administrative costs. This process will allow a grantee to access funds for program administrative costs while the grantee begins developing its Public Action Plan in DRGR as provided in section III.C.1. of the Consolidated Notice.

**III.A.1.d. Incorporation of the action plan for program administrative costs into the Public Action Plan.** The grantee shall describe the use of all grant funds for administrative costs in the Public Action Plan required by section III.C.1. Use of grant funds for administrative

costs before approval of the Public Action Plan must be consistent with the action plan for administrative costs. Once the Public Action Plan is approved, the use of all grant funds must be consistent with the Public Action Plan. Upon HUD's approval of the Public Action Plan, the action plan for administrative costs shall only be relevant to administrative costs charged to the grant before the date of approval of the Public Action Plan.

**III.A.2. Use of administrative funds across multiple grants.** The Appropriations Act authorizes special treatment of grant administrative funds. Grantees that are receiving awards under this notice, and that have received CDBG-DR or CDBG-MIT grants in the past or in any future acts, may use eligible administrative funds (up to five percent of each grant award plus up to five percent of program income generated by the grant) appropriated by these acts for the cost of administering any CDBG-DR or CDBG-MIT grant without regard to the particular disaster appropriation from which such funds originated. If the grantee chooses to exercise this authority, the grantee must have appropriate financial controls to comply with the requirement that the amount of grant administration expenditures for each CDBG-DR or CDBG-MIT grant will not exceed five percent of the total grant award for each grant (plus five percent of program income generated by the grant), review and modify its financial management policies and procedures regarding the tracking and accounting of administration costs, as necessary, and address the adoption of this treatment of administrative costs in the applicable portions of its Financial Management and Grant Compliance submissions as referenced in section III.A.1. of the Consolidated Notice. Grantees are reminded that all uses of funds for program administrative activities must qualify as an eligible administration cost.

#### **IV. Applicable Rules, Statutes, Waivers, and Alternative Requirements**

The Appropriations Act authorizes the Secretary to waive or specify alternative requirements for any provision of any statute or regulation that the Secretary administers in connection with the obligation by the Secretary, or use by the recipient, of these funds, except for requirements related to fair housing, nondiscrimination, labor standards, and the environment. This section of the notice and the Consolidated Notice describe rules, statutes, waivers, and alternative requirements that apply to

allocations under this notice. For each waiver and alternative requirement in this notice and incorporated through the Consolidated Notice, the Secretary has determined that good cause exists, and the waiver or alternative requirement is not inconsistent with the overall purpose of title I of the HCDA. The waivers and alternative requirements provide flexibility in program design and implementation to support full and swift recovery following eligible disasters, while ensuring that statutory requirements are met.

Grantees may request additional waivers and alternative requirements from the Department as needed to address specific needs related to their recovery and mitigation activities. Grantees should work with the assigned CPD representative to request any additional waivers or alternative requirements from HUD headquarters. Waivers and alternative requirements described below apply to all grantees under this notice. Under the requirements of the Appropriations Act, waivers and alternative requirements are effective five days after they are published in the **Federal Register** or on the website of the Department.

##### **A. Grant Administration**

**IV.A.1. Duplication of Benefits (DOB).** HUD published a **Federal Register** notice on June 20, 2019, titled, "Updates to Duplication of Benefits Requirements Under the Stafford Act for Community Development Block Grant (CDBG) Disaster Recovery Grantees" (84 FR 28836) ("2019 DOB Notice"), which revised the DOB requirements that apply to CDBG-DR grants for disasters declared between January 1, 2015 and December 31, 2021. To comply with the Stafford Act and the Appropriations Act, grantees must prevent the duplication of benefits and must have adequate policies and procedures for this purpose. Accordingly, grantees that received funds for disasters occurring in 2020 must follow all requirements in the 2019 DOB Notice and the requirements located in section IV.A. of the Consolidated Notice.

**IV.A.2. CDBG-DR mitigation set-aside.** The Appropriations Act requires HUD to include in any allocation of CDBG-DR funds for unmet needs an additional amount of 15 percent for mitigation activities ("CDBG-DR mitigation set-aside"). Grantees should consult Table 1 for the amount allocated specifically for the CDBG-DR mitigation set-aside. For purposes of grants under this notice, mitigation activities are defined as those activities that increase resilience to disasters and reduce or eliminate the long-term risk of loss of

life, injury, damage to and loss of property, and suffering and hardship, by lessening the impact of future disasters.

In the grantee's action plan, it must identify how the proposed use of the CDBG-DR mitigation set-aside will: (1) Meet the definition of mitigation activities; (2) address the current and future risks as identified in the grantee's mitigation needs assessment in the MID areas; (3) be CDBG-eligible activities under title I of the HCDA or otherwise eligible pursuant to a waiver or alternative requirement; and (4) meet a national objective.

Unlike recovery activities where grantees must demonstrate that their activities "tie-back" to the specific disaster and address a specific unmet recovery need for which the CDBG-DR funds were appropriated, activities funded by the CDBG-DR mitigation set-aside do not require such a "tie-back" to the specific qualified disaster that has served as the basis for the grantee's allocation. Instead, grantees must demonstrate that activities funded by the CDBG-DR mitigation set-aside meet the provisions included as (1) through (4) in the prior paragraph, to be eligible. Grantees must report activities as a "MIT" activity type in DRGR so that HUD and the public can determine that the grantee has met the expenditure requirement for the CDBG-DR mitigation set-aside.

Grantees may also meet the requirement of the CDBG-DR mitigation set-aside by including eligible recovery activities that both address the impacts of the disaster (*i.e.*, have "tie-back" to the specific qualified disaster), and incorporate mitigation measures into the recovery activities. In section II.A.2.b. of the Consolidated Notice, grantees are instructed to incorporate mitigation measures when carrying out activities to construct, reconstruct, or rehabilitate residential or non-residential structures with CDBG-DR funds as part of activities eligible under 42 U.S.C. 5305(a) (including activities authorized by waiver and alternative requirement). Additionally, in section II.A.2.c. of the Consolidated Notice, grantees are required to establish resilience performance metrics for those activities.

If grantees wish to count those activities towards the grantee's CDBG-DR mitigation set-aside, grantees must: (1.) Document how those activities and the incorporated mitigation measures will meet the definition of mitigation, as provided above; and (2.) Report those activities as a "MIT" activity type in DRGR so they are easily tracked.

**IV.A.2.a. Mitigation needs assessment.** In addition to the requirements prescribed in section III.C.1.a of the

Consolidated Notice that grantees must develop an impact and unmet needs assessment, grantees receiving an award under this Allocation Announcement Notice must also include in their action plan a mitigation needs assessment to inform the activities funded by the CDBG–DR mitigation set-aside. Each grantee must assess the characteristics and impacts of current and future hazards identified through its recovery from the qualified disaster and any other Presidentially declared disaster. Mitigation solutions designed to be resilient only for threats and hazards related to a prior disaster can leave a community vulnerable to negative effects from future extreme events related to other threats or hazards. When risks are identified among other vulnerabilities during the framing and design of mitigation projects, implementation of those projects can enhance protection and save lives, maximize the utility of scarce resources, and benefit the community long after the projects are complete.

Accordingly, each grantee receiving a CDBG–DR allocation under this notice must conduct a risk-based assessment to inform the use of its CDBG–DR mitigation set-aside considering identified current and future hazards. Grantees must assess their mitigation needs in a manner that effectively addresses risks to indispensable services that enable continuous operation of critical business and government functions, and are critical to human health and safety or economic security. In the mitigation needs assessment, each grantee must cite data sources and must, at a minimum, use the risks identified in the current FEMA-approved state or local Hazard Mitigation Plan (HMP). If a jurisdiction is currently updating an expired HMP, the grantee's agency administering the CDBG–DR funds must consult with the agency administering the HMP update to identify the risks that will be included in the assessment. Mitigation needs evolve over time and grantees are to amend the mitigation needs assessment and action plan as conditions change, additional mitigation needs are identified, and additional resources become available.

*IV.A.2.b. Connection of programs and projects to the mitigation needs assessment.* Grantees are required by section III.C.1.b. of the Consolidated Notice to describe the connection between identified unmet needs and the allocation of CDBG–DR resources. In a similar fashion, the plan must provide a clear connection between a grantee's mitigation needs assessment and its

proposed activities in the MID areas funded by the CDBG–DR mitigation set-aside (or outside in connection to the MID areas as described in section II.A.3. of the Consolidated Notice). To maximize the impact of all available funds, grantees are encouraged to coordinate and align these funds with other projects funded with CDBG–DR and CDBG–MIT funds, as well as other disaster recovery activities funded by FEMA, USACE, the U.S. Forest Service, and other agencies as appropriate. Grantees are encouraged to fund planning activities that complement FEMA's Building Resilient Infrastructure and Communities (BRIC) program and to upgrade mapping, data, and other capabilities to better understand evolving disaster risks.

*IV.A.3. Interchangeability of disaster funds.* The Appropriations Act gives the Secretary authority to authorize grantees that receive an award in this Allocation Announcement Notice and under prior appropriations to use those funds interchangeably and without limitation for the same activities related to unmet recovery needs in the MID areas resulting from a major disaster in the Appropriation Act or in a prior or future appropriation acts, when the MID areas overlap and when the use of the funds will address unmet recovery needs of major disasters in the Appropriation Act or in any prior or future appropriation acts.

Based on this authority, the Secretary authorizes grantees receiving a CDBG–DR grant under the Appropriation Act and prior or future appropriations acts for activities authorized under title I of the HCDA for a specific qualifying disaster(s) to use these funds interchangeably and without limitation for the same activities in MID areas resulting from a major disaster in a prior or future appropriation acts, as long as the MID areas overlap, and the activities address unmet needs of both disasters.

Grantees are reminded that expanding the eligible beneficiaries of activities in an action plan funded by any prior or future acts to include those impacted by the specific qualifying disaster(s) in this notice requires the submission of a substantial action plan amendment in accordance with section III.C.6. of the Consolidated Notice. Additionally, all waivers and alternative requirements associated with a CDBG–DR grant apply to the use of the funds provided by that grant, regardless of which disaster the funded activity will address.

For example, if a grantee is receiving funds under this notice for a disaster occurring in 2020 and the MID areas for

the 2020 disaster overlap with the MID areas for a disaster that occurred in 2017, the grantee may choose to use the funds allocated under this notice to address unmet needs of both the 2017 disaster and the 2020 disaster. In doing so, the grantee must follow the rules and requirements outlined in this notice. However, if the grantee chooses to use its CDBG–DR grant awarded due to a disaster that occurred in 2017 to address unmet needs of both that disaster and the 2020 disaster, the grantee must follow the rules and requirements outlined in the **Federal Register** notices applicable to its CDBG–DR grant for 2017 disasters.

#### **V. Duration of Funding**

The Appropriations Act makes the funds available for obligation by HUD until expended. HUD waives the provisions at 24 CFR 570.494 and 24 CFR 570.902 regarding timely distribution and expenditure of funds, and establishes an alternative requirement providing that each grantee must expend 100 percent of its allocation within six years of the date HUD signs the grant agreement. HUD may extend the period of performance administratively, if good cause for such an extension exists at that time, as requested by the grantee, and approved by HUD. When the period of performance has ended, HUD will close out the grant and any remaining funds not expended by the grantee on appropriate programmatic purposes will be recaptured by HUD.

#### **VI. Federal Assistance Listings (Formerly Known as the CFDA Number)**

The Catalog of Federal Domestic Assistance numbers for the disaster recovery grants under this notice are as follows: 14.218; 14.228.

#### **VII. Finding of No Significant Impact**

A Finding of No Significant Impact (FONSI) with respect to the environment has been made in accordance with HUD regulations at 24 CFR part 50, which implement section 102(2)(C) of the National Environmental Policy Act of 1969 (42 U.S.C. 4332(2)(C)). The FONSI is available online on HUD's CDBG–DR website. Due to security measures at the HUD Headquarters building, an advance appointment to review the docket file must be scheduled by calling the

Regulations Division at 202–708–3055 (this is not a toll-free number).

**James Arthur Jemison II,**

*Principal Deputy Assistant Secretary for Community Planning and Development.*

**Appendix A—Detailed Methodology**

**Allocation of CDBG–DR Funds to Most Impacted and Distressed Areas Due to Presidentially Declared Disasters Occurring in 2020**

**Background**

Public Law No: 117–43 on 9/30/2021 (the Disaster Relief Supplemental Appropriations Act, 2022) appropriated \$5 billion for CDBG–Disaster Recovery (CDBG–DR) funds for disasters occurring in 2020 and 2021. The statutory text related to the allocation is as follows:

“For an additional amount for ‘Community Development Fund’, \$5,000,000,000, to remain available until expended, for necessary expenses for activities authorized under title I of the Housing and Community Development Act of 1974 (42 U.S.C. 5301 *et seq.*) related to disaster relief, long-term recovery, restoration of infrastructure and housing, economic revitalization, and mitigation, in the most impacted and distressed areas resulting from a major disaster that occurred in 2020 or 2021 pursuant to the Robert T. Stafford Disaster Relief and Emergency Assistance Act (42 U.S.C. 5121 *et seq.*): *Provided*, That amounts made available under this heading in this Act shall be awarded directly to the state, unit of general local government, or Indian tribe (as such term is defined in section 102 of the Housing and Community Development Act of 1974 (42 U.S.C. 5302)) at the discretion of the Secretary: *Provided further*, That the Secretary shall allocate, using the best available data, an amount equal to the total estimate for unmet needs for qualifying disasters under this heading in this Act: *Provided further*, That any final allocation for the total estimate for unmet need made available under the preceding proviso shall include an additional amount of 15 percent of such estimate for additional mitigation: *Provided further*, That of the amounts made available under this heading in this Act, no less than \$1,610,000,000 shall be allocated for major declared disasters that occurred in 2020 within 30 days of the date of enactment of this Act:”

**Most Impacted and Distressed Areas**

As with prior CDBG–DR appropriations, HUD is not obligated to allocate funds for all major disasters occurring in the statutory timeframes. HUD is directed to use the funds “in the most impacted and distressed areas.” HUD has implemented this directive by limiting CDBG–DR formula allocations to grantees with major disasters that meet three standards:

(1) Individual Assistance/IHP designation. HUD has limited allocations to those disasters where the Federal Emergency Management Agency (FEMA) had determined the damage was sufficient to declare the disaster as eligible to receive Individual and Households Program (IHP) funding.

(2) Concentrated damage. HUD has limited its estimate of serious unmet housing need to counties and ZIP codes with high levels of damage, collectively referred to as “most impacted areas.” For this allocation, HUD is defining most impacted areas as either most impacted counties—counties exceeding \$10 million in serious unmet housing needs—and most impacted Zip Codes—Zip Codes with \$2 million or more of serious unmet housing needs. The calculation of serious unmet housing needs is described below.

For disasters that meet the most impacted threshold described above, the unmet need allocations are based on the following factors summed together:

(1) Repair estimates for seriously damaged owner-occupied units without insurance (with some exceptions) in most impacted areas after FEMA and Small Business Administration (SBA) repair grants or loans; an estimate for homeowners served by FEMA’s Permanent Housing Construction program is also deducted from the homeowner unmet need estimate;

(2) Repair estimates for seriously damaged rental units occupied by very low-income renters in most impacted areas;

(3) Repair and content loss estimates for small businesses with serious damage denied by SBA; and

(4) The estimated local cost share for Public Assistance Category C to G projects.

**Methods for Estimating Serious Unmet Needs for Housing**

The data HUD uses to calculate unmet needs for 2020 qualifying disasters come from the FEMA Individual Assistance program data on housing-unit damage as of September 30, 2021, and reflect disasters occurring in 2020.

The core data on housing damage for both the unmet housing needs calculation and the concentrated damage are based on home inspection data for FEMA’s Individual Assistance program and SBA’s disaster loan program. HUD calculates “unmet housing needs” as the number of housing units with unmet needs times the estimated cost to repair those units less repair funds already provided by FEMA and SBA.

Each of the FEMA inspected owner units are categorized by HUD into one of five categories:

- Minor-Low: Less than \$3,000 of FEMA inspected real property damage.

- Minor-High: \$3,000 to \$7,999 of FEMA inspected real property damage.

- Major-Low: \$8,000 to \$14,999 of FEMA inspected real property damage and/or 1 to 3.9 feet of flooding on the first floor.

- Major-High: \$15,000 to \$28,800 of FEMA inspected real property damage and/or 4 to 5.9 feet of flooding on the first floor.

- Severe: Greater than \$28,800 of FEMA inspected real property damage or determined destroyed and/or 6 or more feet of flooding on the first floor.

When owner-occupied properties also have a personal property inspection or only have a personal property inspection, HUD reviews the personal property damage amounts such that if the personal property damage places the home into a higher need category over the real property assessment, the personal

property amount is used. The personal property-based need categories for owner-occupied units are defined as follows:

- Minor-Low: Less than \$2,500 of FEMA inspected personal property damage.

- Minor-High: \$2,500 to \$3,499 of FEMA inspected personal property damage.

- Major-Low: \$3,500 to \$4,999 of FEMA inspected personal property damage or 1 to 3.9 feet of flooding on the first floor.

- Major-High: \$5,000 to \$9,000 of FEMA inspected personal property damage or 4 to 5.9 feet of flooding on the first floor.

- Severe: Greater than \$9,000 of FEMA inspected personal property damage or determined destroyed and/or 6 or more feet of flooding on the first floor.

To meet the statutory requirement of “most impacted” in this legislative language, homes are determined to have a high level of damage if they have damage of “major-low” or higher. That is, they have a FEMA inspected real property damage of \$8,000 or above, personal property damage \$3,500 or above, or flooding 1 foot or above on the first floor.

Furthermore, a homeowner with flooding outside the 1 percent risk flood hazard area is determined to have unmet needs if they reported damage and no flood insurance to cover that damage. For homeowners inside the 1 percent risk flood hazard area, homeowners without flood insurance with flood damage below the greater of national median or 120 percent of Area Median Income are determined to have unmet needs. For non-flood damage, homeowners without hazard insurance with incomes below the greater of national median or 120 percent of Area Median Income are included as having unmet needs. The unmet need categories for these types of homeowners are defined as above for real and personal property damage.

FEMA does not inspect rental units for real property damage so personal property damage is used as a proxy for unit damage. Each of the FEMA-inspected renter units are categorized by HUD into one of five categories:

- Minor-Low: Less than \$1,000 of FEMA inspected personal property damage.

- Minor-High: \$1,000 to \$1,999 of FEMA inspected personal property damage or determination of “Moderate” damage by the FEMA inspector.

- Major-Low: \$2,000 to \$3,499 of FEMA inspected personal property damage or 1 to 3.9 feet of flooding on the first floor or determination of “Major” damage by the FEMA inspector.

- Major-High: \$3,500 to \$7,500 of FEMA inspected personal property damage or 4 to 5.9 feet of flooding on the first floor.

- Severe: Greater than \$7,500 of FEMA inspected personal property damage or determined destroyed and/or 6 or more feet of flooding on the first floor or determination of “Destroyed” by the FEMA inspector.

To meet the statutory requirement of “most impacted” for rental properties, homes are determined to have a high level of damage if they have damage of “major-low” or higher. That is, they have a FEMA personal property damage assessment of \$2,000 or greater or flooding 1 foot or above on the first floor.

Furthermore, landlords are presumed to have adequate insurance coverage unless the



unit is occupied by a renter with income less than the greater of the Federal poverty level or 50 percent of the area median income. Units occupied by a tenant with income less than the greater of the poverty level or 50 percent of the area median income are used to calculate likely unmet needs for affordable rental housing.

The average cost to fully repair a home for a specific disaster to code within each of the damage categories noted above is calculated using the median real property damage repair costs determined by the SBA for its disaster loan program based on a fuzzy match at the block group level comparing FEMA and SBA inspections.

Minimum multipliers are not less than the 25th percentile for all Individual Assistance (IA) eligible disasters combined in each disaster year at the time of the allocation calculation, and maximum multipliers are not more than the 75th percentile for all IA eligible disasters combined in each disaster year with data available as of the allocation. Because SBA is inspecting for full repair costs, their estimate is presumed to reflect the full cost to repair the home, which is generally more than the FEMA estimates on the cost to make the home habitable. If there is a match of fewer than 10 SBA inspections to FEMA inspections for any damage category in a block group, the minimum multiplier is used.

For each household determined to have serious unmet housing needs (as described above), their estimated average unmet housing need is equal to the average cost to fully repair a home to code less assistance from FEMA and SBA provided for repair to the home, based on the home's damage category (noted above) unless a FEMA inspection exceeds the multiplier, in which case the FEMA inspection is used (capped at the maximum noted above).

#### Methods for Estimating Serious Unmet Economic Revitalization Needs

Based on SBA disaster loans to businesses using data for 2020 disasters from as of date September 28, 2021, HUD calculates the median real estate and content loss by the following damage categories for each state:

- Category 1: Real estate + content loss = below \$12,000
- Category 2: Real estate + content loss = \$12,000–\$29,999
- Category 3: Real estate + content loss = \$30,000–\$64,999
- Category 4: Real estate + content loss = \$65,000–\$149,999
- Category 5: Real estate + content loss = \$150,000 and above

For properties with real estate and content loss of \$30,000 or more, HUD calculates the estimated amount of unmet needs for small businesses by multiplying the median damage estimates for the categories above by the number of small businesses denied an SBA loan, including those denied a loan prior to inspection due to inadequate credit or income (or a decision had not been made), under the assumption that damage among those denied at pre-inspection have the same distribution of damage as those denied after inspection.

#### Methods for Estimating Unmet Infrastructure Needs

To calculate 2020 unmet needs for infrastructure projects, HUD obtained FEMA cost estimates as of September 28, 2021, of the expected local cost share to repair the permanent public infrastructure projects (Categories C to G) to pre-disaster condition.

#### Allocation Calculation for Unmet Needs

Once eligible entities are identified using the above criteria, the allocation to individual grantees represents their proportional share of the estimated unmet needs. For the formula allocation, HUD calculates total unmet recovery needs for eligible 2020 disasters as the aggregate of:

- Serious unmet housing needs in most impacted counties;
- Serious unmet business needs; and
- Unmet infrastructure need.

#### Allocation Calculation for Mitigation

Per the statute, mitigation is calculated at 15 percent of the sum of total unmet needs above.

#### Adjustment for Previous Unmet Need Allocation and Final Allocation

If a disaster has previously received CDBG–DR funding for a portion of the unmet needs calculated for the disaster, which is the case for Puerto Rico that had received 2019 disaster funding for the earthquakes that occurred in both 2019 and 2020, then the amount allocated from 2020 funds reflects the total unmet needs calculated above, the 15 percent mitigation for the total unmet needs, less the CDBG–DR funding previously received.

### Appendix B—The Consolidated Notice CDBG–DR Consolidated Notice Waivers and Alternative Requirements

#### Table of Contents

- I. Waivers and Alternative Requirements
- II. Eligible Activities
  - A. Clarification of Disaster-Related Activities
  - B. Housing and Related Floodplain Issues
  - C. Infrastructure (Public Facilities, Public Improvements)
  - D. Economic Revitalization
- III. Grant Administration
  - A. Pre-Award Evaluation of Management and Oversight of Funds
  - B. Administration, Planning, and Financial Management
  - C. Action Plan for Disaster Recovery Waiver and Alternative Requirement
  - D. Citizen Participation Requirements
  - E. Program Income
  - F. Other General Waivers and Alternative Requirements
  - G. Ineligible Activities in CDBG–DR
- IV. Other Program Requirements
  - A. Duplication of Benefits
  - B. Procurement
  - C. Use of the “Upper Quartile” or “Exception Criteria”
  - D. Environmental Requirements
  - E. Flood Insurance Requirements
  - F. URA, Section 104(d) and Related CDBG Program Requirements
- V. Performance Reviews

- A. Timely Distribution and Expenditure of Funds
- B. HUD's Review of Continuing Capacity
- C. Grantee Reporting Requirements in the DRGR System

#### I. Waivers and Alternative Requirements

CDBG–DR grantees that are subject to this Consolidated Notice, as indicated in each **Federal Register** notice that announces allocations of the appropriated CDBG–DR funds (“Allocation Announcement Notice”), must comply with all waivers and alternative requirements in the Consolidated Notice, unless expressly made inapplicable (e.g., a waiver that applies to states only does not apply to units of general local governments and Indian tribes). Except as described in applicable waivers and alternative requirements, the statutory and regulatory provisions governing the CDBG program (and for Indian tribes, the Indian CDBG program) shall apply to grantees receiving a CDBG–DR allocation. Statutory provisions (title I of the HCDA) that apply to all grantees can be found at 42 U.S.C. 5301 *et seq.* and regulatory requirements, which differ for each type of grantee, are described in each of the three paragraphs below.

Except as modified, the State CDBG program rules shall apply to state grantees receiving a CDBG–DR allocation. Applicable State CDBG program regulations are found at 24 CFR part 570, subpart I. For insular areas, HUD waives the provisions of 24 CFR part 570, subpart F and imposes the following alternative requirement: Insular areas shall administer their CDBG–DR allocations in accordance with the regulatory and statutory provisions governing the State CDBG program, as modified by the Consolidated Notice.

Except as modified, statutory and regulatory provisions governing the Entitlement CDBG Program shall apply to unit of general local government grantees (often referred to as local government grantees in appropriations acts). Applicable Entitlement CDBG Program regulations are found at 24 CFR part 570, as described in 570.1(a).

Except as modified, CDBG–DR grants made by HUD to Indian tribes shall be subject to the statutory provisions in title I of the HCDA that apply to Indian tribes and the regulations in 24 CFR part 1003 governing the Indian CDBG program, except those requirements in part 1003 related to the funding application and selection process.

References to the action plan in the above regulations shall refer to the action plan required by the Consolidated Notice and not to the consolidated plan action plan required by 24 CFR part 91. All references pertaining to timelines and/or deadlines are in terms of calendar days unless otherwise noted.

#### II. Eligible Activities

##### II.A. Clarification of Disaster-Related Activities

CDBG–DR funds are provided for necessary expenses for activities authorized under title I of the HCDA related to disaster relief, long-term recovery, restoration of infrastructure and housing, economic revitalization, and mitigation of risk associated with activities

carried out for these purposes, in the “most impacted and distressed” areas (identified by HUD or the grantee) resulting from a major disaster. All CDBG–DR funded activities must address an impact of the disaster for which funding was allocated. Accordingly, each activity must: (1) Address a direct or indirect impact from the disaster in a most impacted and distressed area; (2) be a CDBG-eligible activity (or be eligible under a waiver or alternative requirement); and (3) meet a national objective. When appropriations acts provide an additional allocation amount for mitigation of hazard risks that does not require a connection to the qualifying major disaster, requirements for the use of those funds will be included in the Allocation Announcement Notice.

**II.A.1. Documenting a Connection to the Disaster.** Grantees must maintain records that document how each funded activity addresses a direct or indirect impact from the disaster. Grantees may do this by linking activities to a disaster recovery need that is described in the impact and unmet needs assessment in the action plan (requirements for the assessment are addressed in section III.C.1.a.). Sufficient documentation of physical loss must include damage or rebuilding estimates, insurance loss reports, images, or similar information that documents damage caused by the disaster. Sufficient documentation for non-physical disaster-related impacts must clearly show how the activity addresses the disaster impact, *e.g.*, for economic development activities, data about job loss or businesses closing after the disaster or data showing how pre-disaster economic stressors were aggravated by the disaster; or for housing activities, a post-disaster housing analysis that describes the activities that are necessary to address the post-disaster housing needs.

**II.A.2. Resilience and hazard mitigation.** The Consolidated Notice will help to improve long-term community resilience by requiring grantees to fully incorporate mitigation measures that will protect the public, including members of protected classes, vulnerable populations, and underserved communities, from the risks identified by the grantee among other vulnerabilities. This approach will better ensure the revitalization of the community long after the recovery projects are complete.

Accordingly, HUD is adopting the following alternative requirement to section 105(a): Grantees may carry out the activities described in section 105(a), as modified by waivers and alternative requirements, to the extent that the activities comply with the following:

**II.A.2.a. Alignment with mitigation plans.** Grantees must ensure that the mitigation measures identified in their action plan will align with existing hazard mitigation plans submitted to the Federal Emergency Management Agency (FEMA) under section 322 of the Robert T. Stafford Disaster Relief and Emergency Assistance Act (42 U.S.C. 5165) or other state, local, or tribal hazard mitigation plans.

**II.A.2.b. Mitigation measures.** Grantees must incorporate mitigation measures when carrying out activities to construct, reconstruct, or rehabilitate residential or non-

residential structures with CDBG–DR funds as part of activities eligible under 42 U.S.C. 5305(a) (including activities authorized by waiver and alternative requirement). To meet this alternative requirement, grantees must demonstrate that they have incorporated mitigation measures into CDBG–DR activities as a construction standard to create communities that are more resilient to the impacts of recurring natural disasters and the impacts of climate change. When determining which mitigation measures to incorporate, grantees should design and construct structures to withstand existing and future climate impacts expected to occur over the service life of the project.

**II.A.2.c. Resilience performance metrics.** Before carrying out CDBG–DR funded activities to construct, reconstruct, or rehabilitate residential or non-residential structures, the grantee must establish resilience performance metrics for the activity, including: (1) An estimate of the projected risk to the completed activity from natural hazards, including those hazards that are influenced by climate change (*e.g.*, high winds destroying newly built homes), (2) identification of the mitigation measures that will address the projected risks (*e.g.*, using building materials that are able to withstand high winds), and (3) an assessment of the benefit of the grantee’s measures through verifiable data (*e.g.*, 10 newly built homes will withstand high winds up to 100 mph).

**II.A.3. Most impacted and distressed (MID) areas.** Funds must be used for costs related to unmet needs in the MID areas resulting from qualifying disasters. HUD allocates funds using the best available data that cover the eligible affected areas and identifies MID areas. Grantees are required to use 80 percent of all CDBG–DR funds to benefit the HUD-identified MID areas and the minimum dollar amount that must be spent to benefit those areas will be identified for each grantee in the applicable Allocation Announcement Notice. If a grantee seeks to add other areas to the HUD-identified MID area, the grantee must contact its CPD Representative or CPD Specialist and submit the request with a data-driven analysis that illustrates the basis for designating the additional area as most impacted and distressed as a result of the qualifying disaster.

Grantees may use up to five percent of the total grant award for grant administration. Therefore, HUD will include 80 percent of a grantee’s expenditures for grant administration in its determination that 80 percent of the total award has benefited the HUD-identified MID area. Expenditures for planning activities may also be counted towards the HUD-identified MID area requirement, if the grantee describes in its action plan how those planning activities benefit those areas.

HUD may identify an entire jurisdiction or a ZIP code as a MID area. If HUD designates a ZIP code as a MID area for the purposes of allocating funds, the grantee may expand program operations to the whole county or counties that overlap with the HUD designated ZIP code. A grantee must indicate the decision to expand eligibility to the whole county or counties in its action plan.

Grantees must determine where to use the remaining amount of the CDBG–DR grant, but that portion of the allocation may only be used to address unmet needs and that benefit those areas that the grantee determines are most impacted and distressed (“grantee-identified MID areas”) within areas that received a presidential major disaster declaration identified by the disaster numbers listed in the applicable Allocation Announcement Notice. The grantee must use quantifiable and verifiable data in its analysis, as referenced in its action plan, to identify the MID areas where it will use the remaining amount of CDBG–DR funds.

Grantee expenditures for eligible unmet needs outside of the HUD-identified or grantee-identified MID areas are allowable, provided that the grantee can demonstrate how the expenditure of CDBG–DR funds outside of the MID areas will address unmet needs identified within the HUD-identified or grantee-identified MID area (*e.g.*, upstream water retention projects to reduce downstream flooding in the HUD-identified MID area).

### *II.B. Housing Activities and Related Floodplain Issues*

Grantees may use CDBG–DR funds for activities that may include, but are not limited to, new construction, reconstruction, and rehabilitation of single-family or multifamily housing, homeownership assistance, buyouts, and rental assistance. The broadening of eligible CDBG–DR activities related to housing under the HCDA is necessary following major disasters in which housing, including large numbers of affordable housing units, have been damaged or destroyed. The following waivers and alternative requirements will assist grantees in addressing the full range of unmet housing needs arising from a disaster.

**II.B.1. New housing construction waiver and alternative requirement.** 42 U.S.C. 5305(a) and 24 CFR 570.207(b)(3) are waived to the extent necessary to permit new housing construction, subject to the following alternative requirement. When a CDBG–DR grantee carries out a new housing construction activity, 24 CFR 570.202 shall apply and shall be read to extend to new construction in addition to rehabilitation assistance. Private individuals and entities must remain compliant with federal accessibility requirements as well as with the applicable site selection requirements of 24 CFR 1.4(b)(3) and 8.4(b)(5).

**II.B.2. Construction standards for new construction, reconstruction, and rehabilitation.** HUD is adopting an alternative requirement to require grantees to adhere to the applicable construction standards in II.B.2.a. through II.B.2.d. when carrying out activities to construct, reconstruct, or rehabilitate residential structures with CDBG–DR funds as part of activities eligible under 42 U.S.C. 5305(a) (including activities authorized by waiver and alternative requirement). For purposes of the Consolidated Notice, the terms “substantial damage” and “substantial improvement” shall be as defined in 44 CFR 59.1 unless otherwise noted.

**II.B.2.a. Green and resilient building standard for new construction and**

*reconstruction of housing.* Grantees must meet the Green and Resilient Building Standard, as defined in this subparagraph, for: (i) All new construction and reconstruction (*i.e.*, demolishing a housing unit and rebuilding it on the same lot in substantially the same manner) of residential buildings and (ii) all rehabilitation activities of substantially damaged residential buildings, including changes to structural elements such as flooring systems, columns, or load-bearing interior or exterior walls.

The Green and Resilient Building Standard requires that all construction covered by the paragraph above and assisted with CDBG–DR funds meet an industry-recognized standard that has achieved certification under (i) Enterprise Green Communities; (ii) LEED (New Construction, Homes, Midrise, Existing Buildings Operations and Maintenance, or Neighborhood Development); (iii) ICC–700 National Green Building Standard Green+Resilience; (iv) Living Building Challenge; or (v) any other equivalent comprehensive green building program acceptable to HUD. Additionally, all such covered construction must achieve a minimum energy efficiency standard, such as (i) ENERGY STAR (Certified Homes or Multifamily High-Rise); (ii) DOE Zero Energy Ready Home; (iii) EarthCraft Home, EarthCraft Multifamily; (iv) Passive House Institute Passive Building or EnerPHit certification from the Passive House Institute US (PHIUS), International Passive House Association; (v) Greenpoint Rated New Home, Greenpoint Rated Existing Home (Whole House or Whole Building label); (vi) Earth Advantage New Homes; or (vii) any other equivalent energy efficiency standard acceptable to HUD. Grantees must identify, in each project file, which of these Green and Resilient Building Standards will be used for any building subject to this paragraph. However, grantees are not required to use the same standards for each project or building.

**II.B.2.b. Standards for rehabilitation of nonsubstantially damaged residential buildings.** For rehabilitation other than the rehabilitation of substantially damaged residential buildings described in section II.B.2.a. above, grantees must follow the guidelines specified in the HUD CPD Green Building Retrofit Checklist.

Grantees must apply these guidelines to the extent applicable for the rehabilitation work undertaken, for example, the use of mold resistant products when replacing surfaces such as drywall. Products and appliances replaced as part of the rehabilitation work, must be ENERGY STAR-labeled, WaterSense-labeled, or Federal Energy Management Program (FEMP)-designated products or appliances.

**II.B.2.c. Elevation standards for new construction, reconstruction, and rehabilitation of substantial damage, or rehabilitation resulting in substantial improvements.** The following elevation standards apply to new construction, rehabilitation of substantial damage, or rehabilitation resulting in substantial improvement of residential structures located in an area delineated as a special flood hazard area or equivalent in FEMA's data sources. 24 CFR 55.2(b)(1) provides

additional information on data sources, which apply to all floodplain designations. All structures, defined at 44 CFR 59.1, designed principally for residential use, and located in the one percent annual chance (or 100-year) floodplain, that receive assistance for new construction, reconstruction, rehabilitation of substantial damage, or rehabilitation that results in substantial improvement, as defined at 24 CFR 55.2(b)(10), must be elevated with the lowest floor, including the basement, at least two feet above the one percent annual chance floodplain elevation (base flood elevation). Mixed-use structures with no dwelling units and no residents below two feet above base flood elevation, must be elevated or floodproofed, in accordance with FEMA floodproofing standards at 44 CFR 60.3(c)(3)(ii) or successor standard, up to at least two feet above base flood elevation.

All Critical Actions, as defined at 24 CFR 55.2(b)(3), within the 500-year (or 0.2 percent annual chance) floodplain must be elevated or floodproofed (in accordance with FEMA floodproofing standards at 44 CFR 60.3(c)(2)–(3) or successor standard) to the higher of the 500-year floodplain elevation or three feet above the 100-year floodplain elevation. If the 500-year floodplain is unavailable, and the Critical Action is in the 100-year floodplain, then the structure must be elevated or floodproofed (in accordance with FEMA floodproofing standards at 44 CFR 60.3(c)(2)–(3) or successor standard) at least three feet above the 100-year floodplain elevation. Critical Actions are defined as “any activity for which even a slight chance of flooding would be too great, because such flooding might result in loss of life, injury to persons or damage to property.” For example, Critical Actions include hospitals, nursing homes, emergency shelters, police stations, fire stations, and principal utility lines.

In addition to other requirements in this section, grantees must comply with applicable state, local, and tribal codes and standards for floodplain management, including elevation, setbacks, and cumulative substantial damage requirements. Grantees using CDBG–DR funds as the non-Federal match in a FEMA-funded project may apply the alternative requirement for the elevation of structures described in section III.F.6. Structures that are elevated must meet federal accessibility standards.

**II.B.2.d. Broadband infrastructure in housing.** Any substantial rehabilitation, as defined by 24 CFR 5.100, reconstruction, or new construction of a building with more than four rental units must include installation of broadband infrastructure, except where the grantee documents that: (i) The location of the new construction or substantial rehabilitation makes installation of broadband infrastructure infeasible; (ii) the cost of installing broadband infrastructure would result in a fundamental alteration in the nature of its program or activity, or in an undue financial burden; or (iii) the structure of the housing to be substantially rehabilitated makes installation of broadband infrastructure infeasible.

**II.B.3. Applicable affordability periods for new construction of affordable rental**

*housing.* To meet the low- and moderate-income housing national objective, rental housing assisted with CDBG–DR funds must be rented to low- and moderate-income (LMI) households at affordable rents, and a grantee must define “affordable rents” in its action plan. Because the waiver and alternative requirement in II.B.1. authorizes the use of grant funds for new housing construction, HUD is imposing the following alternative requirement to modify the low- and moderate-income housing national objective criteria in 24 CFR 570.208(a)(3) and 570.483(b)(3) for activities involving the new construction of affordable rental housing of five or more units. For activities that will construct five or more units, in addition to other applicable criteria in 24 CFR 570.208(a)(3) and 570.483(b)(3), in its action plan, a grantee must define the affordability standards, including “affordable rents,” the enforcement mechanisms, and applicable timeframes, that will apply to the new construction of affordable rental housing, *i.e.*, when the activity will result in construction of five or more units, the affordability requirements described in the action plan apply to the units that will be occupied by LMI households. The minimum timeframes and other related requirements acceptable for compliance with this alternative requirement are the HOME Investment Partnerships Program (HOME) requirements at 24 CFR 92.252(e), including the table listing the affordability periods at the end of 24 CFR 92.252(e). Therefore, the grantee must adopt and implement enforceable affordability standards that comply with or exceed requirements at 24 CFR 92.252(e)(1) for the new construction of affordable rental housing in structures containing five or more units.

**II.B.4. Affordability period for new construction of homes built for LMI households.** In addition to alternative requirements in II.B.1., the following alternative requirement applies to activities to construct new single-family units for homeownership that will meet the LMI housing national objective criteria. Grantees must establish affordability restrictions on all newly constructed single-family housing (for purposes of the Consolidated Notice, single-family housing is defined as four units or less), that, upon completion, will be purchased and occupied by LMI homeowners. The minimum affordability period acceptable for compliance are the HOME requirements at 24 CFR 92.254(a)(4). If a grantee applies other standards, the periods of affordability applied by a grantee must meet or exceed the applicable HOME requirements in 24 CFR 92.254(a)(4) and the table of affordability periods directly following that provision. Grantees shall establish resale or recapture requirements for housing funded pursuant to this paragraph and shall describe those requirements in the action plan or substantial amendment in which the activity is proposed. The resale or recapture requirements must clearly describe the terms of resale or recapture and the specific circumstances under which resale or recapture will be used. Affordability restrictions must be enforceable and imposed by recorded deed restrictions, covenants, or other similar mechanisms. The affordability

restrictions, including the affordability period requirements in this paragraph do not apply to housing units newly constructed or reconstructed for an owner-occupant to replace the owner-occupant's home that was damaged by the disaster.

**II.B.5. Homeownership assistance waiver and alternative requirement.** 42 U.S.C. 5305(a)(24) is waived and replaced with the following alternative requirement:

"Provision of direct assistance to facilitate and expand homeownership among persons at or below 120 percent of area median income (except that such assistance shall not be considered a public service for purposes of 42 U.S.C. 5305(a)(8)) by using such assistance to—

(A) subsidize interest rates and mortgage principal amounts for homebuyers with incomes at or below 120 percent of area median income;

(B) finance the acquisition of housing by homebuyers with incomes at or below 120 percent of area median income that is occupied by the homebuyers;

(C) acquire guarantees for mortgage financing obtained by homebuyers with incomes at or below 120 percent of area median income from private lenders, meaning that if a private lender selected by the homebuyer offers a guarantee of the mortgage financing, the grantee may purchase the guarantee to ensure repayment in case of default by the homebuyer. This subparagraph allows the purchase of mortgage insurance by the household but not the direct issuance of mortgage insurance by the grantee;

(D) provide up to 100 percent of any down payment required from homebuyers with incomes at or below 120 percent of area median income; or

(E) pay reasonable closing costs (normally associated with the purchase of a home) incurred by homebuyers with incomes at or below 120 percent of area median income."

While homeownership assistance, as described above, may be provided to households with incomes at or below 120 percent of the area median income, HUD will only consider those funds used for households with incomes at or below 80 percent of the area median income to qualify as meeting the LMI person benefit national objective.

**II.B.6. Limitation on emergency grant payments—interim mortgage assistance.** 42 U.S.C. 5305(a)(8), 24 CFR 570.201(e), 24 CFR 570.207(b)(4), and 24 CFR 1003.207(b)(4) are modified to extend interim mortgage assistance (IMA) to qualified individuals from three months to up to twenty months. IMA must be used in conjunction with a buyout program, or the rehabilitation or reconstruction of single-family housing, during which mortgage payments may be due but the home is not habitable. A grantee using this alternative requirement must document, in its policies and procedures, how it will determine that the amount of assistance to be provided is necessary and reasonable.

**II.B.7. Buyout activities.** CDBG—DR grantees may carry out property acquisition for a variety of purposes, but buyouts are a type of acquisition for the specific purpose of

reducing the risk of property damage. HUD has determined that creating a new activity and alternative requirement for buyouts is necessary for consistency with the application of other Federal resources commonly used for this type of activity. Therefore, HUD is waiving 42 U.S.C. 5305(a) and establishing an alternative requirement only to the extent necessary to create a new eligible activity for buyouts. The term "buyouts" means the acquisition of properties located in a floodway, floodplain, or other Disaster Risk Reduction Area that is intended to reduce risk from future hazards. Grantees can designate a Disaster Risk Reduction Area, as defined below.

Grantees carrying out buyout activities must establish an open space management plan or equivalent, if one has not already been established, before implementation. The plan must establish full transparency about the planned use of acquired properties post-buyout, or the process by which the planned use will be determined and enforced.

Buyout activities are subject to all requirements that apply to acquisition activities generally including but not limited to, the Uniform Relocation Assistance and Real Property Acquisition Policies Act of 1970 (URA) (42 U.S.C. 4601, *et seq.*) and its implementing regulations at 49 CFR part 24, subpart B, unless waived or modified by alternative requirements. Only acquisitions that meet the definition of a "buyout" are subject to the post-acquisition land use restrictions imposed by the alternative requirement (II.B.7.a. below). The key factor in determining whether the acquisition is a buyout is whether the intent of the purchase is to reduce risk of property damage from future flooding or other hazards in a floodway, floodplain, or a Disaster Risk Reduction Area. A grantee that will buyout properties in a Disaster Risk Reduction Area must establish criteria in its policies and procedures to designate an area as a Disaster Risk Reduction Area for the buyout, pursuant to the following requirements:

(1) The area has been impacted by the hazard that has been caused or exacerbated by the disaster for which the grantee received its CDBG—DR allocation;

(2) The hazard identified must be a predictable environmental threat to the safety and well-being of program beneficiaries, including members of protected classes, vulnerable populations, and underserved communities, as evidenced by the best available data (e.g., FEMA Repetitive Loss Data, EPA's Environmental Justice Screening and Mapping Tool, HHS's climate change related guidance and data, etc.) and science (such as engineering and structural solutions propounded by FEMA, USACE, other federal agencies, etc.); and

(3) The area must be clearly delineated so that HUD and the public may easily determine which properties are located within the designated area.

Grantees may only redevelop an acquired property if the property is not acquired through a buyout program (*i.e.*, the purpose of acquisition was something other than risk reduction). When acquisitions are not acquired through a buyout program, the purchase price must be consistent with 2

CFR part 200, subpart E—Cost Principles ("cost principles") and the pre-disaster fair market value may not be used.

**II.B.7.a. Buyout requirements:**

(i) Property to be acquired or accepted must be located within a floodway, floodplain, or Disaster Risk Reduction Area.

(ii) Any property acquired or accepted must be dedicated and maintained in perpetuity for a use that is compatible with open space, recreational, floodplain and wetlands management practices, or other disaster-risk reduction practices.

(iii) No new structure will be erected on property acquired or accepted under the buyout program other than:

(a) A public facility that is open on all sides and functionally related to a designated open space (e.g., a park, campground, or outdoor recreation area);

(b) a restroom; or

(c) a flood control structure, provided that:

(1) The structure does not reduce valley storage, increase erosive velocities, or increase flood heights on the opposite bank, upstream, or downstream; and

(2) the local floodplain manager approves the structure, in writing, before commencement of construction of the structure.

(iv) After the purchase of a buyout property with CDBG—DR funds, the owner of the buyout property (including subsequent owners) is prohibited from making any applications to any Federal entity in perpetuity for additional disaster assistance for any purpose related to the property acquired through the CDBG—DR funded buyout, unless the assistance is for an allowed use as described in paragraph (ii) above. The entity acquiring the property may lease or sell it to adjacent property owners or other parties for compatible uses that comply with buyout requirements in return for a maintenance agreement.

(v) A deed restriction or covenant running with the property must require that the buyout property be dedicated and maintained for compatible uses that comply with buyout requirements in perpetuity.

(vi) Grantees must choose from one of two valuation methods (pre-disaster value or post-disaster value) for a buyout program (or a single buyout activity). The grantee must apply its valuation method for all buyouts carried out under the program. If the grantee determines the post-disaster value of a property is higher than the pre-disaster value, a grantee may provide exceptions to its established valuation method on a case-by-case basis. The grantee must describe the process for such exceptions and how it will analyze the circumstances to permit an exception in its buyout policies and procedures. Each grantee must adopt policies and procedures on how it will demonstrate that the amount of assistance for a buyout is necessary and reasonable.

(vii) All buyout activities must be classified using the "buyout" activity type in the Disaster Recovery and Grant Reporting (DRGR) system.

(viii) Any state grantee implementing a buyout program or activity must consult with local or tribal governments within the areas in which buyouts will occur.

**II.B.8. Safe housing incentives in disaster-affected communities.** The limitation on eligible activities in section 42 U.S.C. 5305(a) is waived and HUD is establishing the following alternative requirement to establish safe housing incentives as an eligible activity. A safe housing incentive is any incentive provided to encourage households to relocate to suitable housing in a lower risk area or in an area promoted by the community's comprehensive recovery plan. Displaced persons must receive any relocation assistance to which they are entitled under other legal authorities, such as the URA, section 104(d) of the HCDA, or those described in the Consolidated Notice. The grantee may offer safe housing incentives in addition to the relocation assistance that is legally required.

Grantees must maintain documentation, at least at a programmatic level, describing how the grantee determined the amount of assistance for the incentive was necessary and reasonable, how the incentive meets a national objective, and that the incentives are in accordance with the grantee's approved action plan and published program design(s). A grantee may require the safe housing incentive to be used for a particular purpose by the household receiving the assistance. However, this waiver does not permit a compensation program meaning that funds may not be provided to a beneficiary to compensate the beneficiary for an estimated or actual amount of loss from the declared disaster. Grantees are prohibited from offering housing incentives to a homeowner as an incentive to induce the homeowner to sell a second home, consistent with the prohibition and definition of second home in section II.B.12.

**II.B.9. National objectives for buyouts and safe housing incentives.** Activities that assist LMI persons and meet the criteria for the national objectives described below, including in II.B.10., will be considered to benefit LMI persons unless there is substantial evidence to the contrary and will count towards the calculation of a grantee's overall LMI benefit requirement as described in section III.F.2. The grantee shall appropriately ensure that activities that meet the criteria for any of the national objectives below do not benefit moderate-income persons to the exclusion of low-income persons.

When undertaking buyout activities, to demonstrate that a buyout meets the low- and moderate-income housing (LMH) national objective, grantees must meet all requirements of the HCDA, and applicable regulatory criteria described below. 42 U.S.C. 5305(c)(3) provides that any assisted activity that involves the acquisition of property to provide housing shall be considered to benefit LMI persons only to the extent such housing will, upon completion, be occupied by such persons. In addition, 24 CFR 570.483(b)(3), 24 CFR 570.208(a)(3), and 24 CFR 1003.208(c) apply the LMH national objective to an eligible activity carried out for the purpose of providing or improving permanent residential structures that, upon completion, will be occupied by LMI households.

A buyout program that merely pays homeowners to leave their existing homes

does not guarantee that those homeowners will occupy a new residential structure. Therefore, acquisition-only buyout programs cannot satisfy the LMH national objective criteria.

To meet a national objective that benefits a LMI person, buyout programs can be structured in one of the following ways:

(1) The buyout activity combines the acquisition of properties with another direct benefit—LMI housing activity, such as down payment assistance—that results in occupancy and otherwise meets the applicable LMH national objective criteria;

(2) The activity meets the low- and moderate-income area (LMA) benefit criteria and documents that the acquired properties will have a use that benefits all the residents in a particular area that is primarily residential, where at least 51 percent of the residents are LMI persons. Grantees covered by the "exception criteria" as described in section IV.C. of the Consolidated Notice may apply it to these activities. To satisfy LMA criteria, grantees must define the service area based on the end use of the buyout properties; or

(3) The program meets the criteria for the low- and moderate-income limited clientele (LMC) national objective by restricting buyout program eligibility to exclusively LMI persons and benefiting LMI sellers by acquiring their properties for more than current fair market value (in accordance with the valuation requirements in section II.B.7.a.(vi)).

**II.B.10. For LMI Safe Housing Incentive (LMHI).** The following alternative requirement establishes new LMI national objective criteria that apply to safe housing incentive (LMHI) activities that benefit LMI households. HUD has determined that providing CDBG—DR grantees with an additional method to demonstrate how safe housing incentive activities benefit LMI households will ensure that grantees and HUD can account for and assess the benefit that CDBG—DR assistance for these activities has on LMI households.

The LMHI national objective may be used when a grantee uses CDBG—DR funds to carry out a safe housing incentive activity that benefits one or more LMI persons. To meet the LMHI national objective, the incentive must be (a.) tied to the voluntary acquisition of housing (including buyouts) owned by a qualifying LMI household and made to induce a move outside of the affected floodplain or disaster risk reduction area to a lower-risk area or structure; or (b.) for the purpose of providing or improving residential structures that, upon completion, will be occupied by a qualifying LMI household and will be in a lower risk area.

**II.B.11. Redevelopment of acquired properties.** Although properties acquired through a buyout program may not be redeveloped, grantees may redevelop other acquired properties. For non-buyout acquisitions, HUD has not permitted the grantee to base acquisition cost on pre-disaster fair market value. The acquisition cost must comply with applicable cost principles and with the acquisition requirements at 49 CFR 24, Subpart B, as revised by the Consolidated Notice waivers

and alternative requirements. In addition to the purchase price, grantees may opt to provide optional relocation assistance, as allowable under Section 104 and 105 of the HCDA (42 U.S.C. 5304 and 42 U.S.C. 5305) and 24 CFR 570.606(d), and as expanded by section IV.F.5. of the Consolidated Notice, to the owner of a property that will be redeveloped if: (a.) The property is purchased by the grantee or subrecipient through voluntary acquisition; and (b.) the owner's need for additional assistance is documented. Any optional relocation assistance must provide equal relocation assistance within each class of displaced persons, including but not limited to providing reasonable accommodation exceptions to persons with disabilities. See 24 CFR 570.606(d) for more information on optional relocation assistance. In addition, tenants displaced by these voluntary acquisitions may be eligible for URA relocation assistance. In carrying out acquisition activities, grantees must ensure they are in compliance with the long-term redevelopment plans of the community in which the acquisition and redevelopment is to occur.

**II.B.12. Alternative requirement for housing rehabilitation—assistance for second homes.** HUD is instituting an alternative requirement to the rehabilitation provisions at 42 U.S.C. 5305(a)(4) as follows: Properties that served as second homes at the time of the disaster, or following the disaster, are not eligible for rehabilitation assistance or safe housing incentives. This prohibition does not apply to acquisitions that meet the definition of a buyout. A second home is defined for purposes of the Consolidated Notice as a home that is not the primary residence of the owner, a tenant, or any occupant at the time of the disaster or at the time of application for CDBG—DR assistance. Grantees can verify a primary residence using a variety of documentation including, but not limited to, voter registration cards, tax returns, homestead exemptions, driver's licenses, and rental agreements. Acquisition of second homes at post-disaster fair market value is not prohibited.

**II.C. Infrastructure (Public Facilities, Public Improvements), Match, and Elevation of Non-Residential Structures**

HUD is adopting an alternative requirement to require grantees to adhere to the applicable construction standards and requirements in II.C.1., II.C.2. and II.C.4., which apply only to those eligible activities described in those paragraphs.

**II.C.1. Infrastructure planning and design.** All newly constructed infrastructure that is assisted with CDBG—DR funds must be designed and constructed to withstand extreme weather events and the impacts of climate change. To satisfy this requirement, the grantee must identify and implement resilience performance metrics as described in section II.A.2.

For purposes of this requirement, an infrastructure activity includes any activity or group of activities (including acquisition or site or other improvements), whether carried out on public or private land, that assists the development of the physical assets that are designed to provide or support

services to the general public in the following sectors: Surface transportation, including roadways, bridges, railroads, and transit; aviation; ports, including navigational channels; water resources projects; energy production and generation, including from renewable, nuclear, and hydro sources; electricity transmission; broadband; pipelines; stormwater and sewer infrastructure; drinking water infrastructure; schools, hospitals, and housing shelters; and other sectors as may be determined by the Federal Permitting Improvement Steering Council. For purposes of this requirement, an activity that falls within this definition is an infrastructure activity regardless of whether it is carried out under sections 105(a)(2), 105(a)(4), 105(a)(14), another section of the HCDA, or a waiver or alternative requirement established by HUD. Action plan requirements related to infrastructure activities are found in section III.C.1.e. of the Consolidated Notice.

**II.C.2. Elevation of nonresidential structure.** Nonresidential structures, including infrastructure, assisted with CDBG-DR funds must be elevated to the standards described in this paragraph or floodproofed, in accordance with FEMA floodproofing standards at 44 CFR 60.3(c)(3)(ii) or successor standard, up to at least two feet above the 100-year (or one percent annual chance) floodplain. All Critical Actions, as defined at 24 CFR 55.2(b)(3), within the 500-year (or 0.2 percent annual chance) floodplain must be elevated or floodproofed (in accordance with FEMA floodproofing standards at 44 CFR 60.3(c)(2)–(3) or successor standard) to the higher of the 500-year floodplain elevation or three feet above the 100-year floodplain elevation. If the 500-year floodplain or elevation is unavailable, and the Critical Action is in the 100-year floodplain, then the structure must be elevated or floodproofed at least three feet above the 100-year floodplain elevation. Activities subject to elevation requirements must comply with applicable federal accessibility mandates.

In addition to the other requirements in this section, the grantee must comply with applicable state, local, and tribal codes and standards for floodplain management, including elevation, setbacks, and cumulative substantial damage requirements. Grantees using CDBG-DR funds as the non-Federal match in a FEMA-funded project may apply the alternative requirement for the elevation of structures described in section IV.D.5.

**II.C.3. CDBG-DR funds as match.** As provided by the HCDA, grant funds may be used to satisfy a match requirement, share, or contribution for any other Federal program when used to carry out an eligible CDBG-DR activity. This includes programs or activities administered by the FEMA or the U.S. Army Corps of Engineers (USACE). By law, (codified in the HCDA as a note to section 105(a)) only \$250,000 or less of CDBG-DR funds may be used for the non-Federal cost-share of any project funded by USACE. Appropriations acts prohibit the use of CDBG-DR funds for any activity reimbursable by, or for which funds are also made available by FEMA or USACE.

In response to a disaster, FEMA may implement, and grantees may elect to follow, alternative procedures for FEMA's Public Assistance Program, as authorized pursuant to Section 428 of the Robert T. Stafford Disaster Relief and Emergency Assistance Act ("Stafford Act"). Like other projects, grantees may use CDBG-DR funds as a matching requirement, share, or contribution for Section 428 Public Assistance Projects. For all match activities, grantees must document that CDBG-DR funds have been used for the actual costs incurred for the assisted project and for costs that are eligible, meet a national objective, and meet other applicable CDBG requirements.

**II.C.4. Requirements for flood control structures.** Grantees that use CDBG-DR funds to assist flood control structures (*i.e.*, dams and levees) are prohibited from using CDBG-DR funds to enlarge a dam or levee beyond the original footprint of the structure that existed before the disaster event, without obtaining pre-approval from HUD and any Federal agencies that HUD determines are necessary based on their involvement or potential involvement with the levee or dam. Grantees that use CDBG-DR funds for levees and dams are required to: (1) Register and maintain entries regarding such structures with the USACE National Levee Database or National Inventory of Dams; (2) ensure that the structure is admitted in the USACE PL 84–99 Program (Levee Rehabilitation and Inspection Program); (3) ensure the structure is accredited under the FEMA National Flood Insurance Program; (4) enter the exact location of the structure and the area served and protected by the structure into the DRGR system; and (5) maintain file documentation demonstrating that the grantee has conducted a risk assessment before funding the flood control structure and documentation that the investment includes risk reduction measures.

#### **II.D. Economic Revitalization and Section 3 Requirements on Economic Opportunities**

CDBG-DR funds can be used for CDBG-DR eligible activities related to economic revitalization. The attraction, retention, and return of businesses and jobs to a disaster-impacted area is critical to long-term recovery. Accordingly, for CDBG-DR purposes, economic revitalization may include any CDBG-DR eligible activity that demonstrably restores and improves the local economy through job creation and retention or by expanding access to goods and services. The most common CDBG-DR eligible activities to support economic revitalization are outlined in 24 CFR 570.203 and 570.204 and sections 105(a)(14), (15), and (17) of the HCDA.

Based on the U.S. Change Research Program's Fourth National Climate Assessment, climate-related natural hazards, extreme events, and natural disasters disproportionately affect LMI individuals who belong to underserved communities because they are less able to prepare for, respond to, and recover from the impacts of extreme events and natural hazards, or are members of communities that have experienced significant disinvestment and historic discrimination. Therefore, HUD is imposing the following alternative

requirement: When funding activities under section 105(a) of the HCDA that support economic revitalization, grantees must prioritize those underserved communities that have been impacted by the disaster and that were economically distressed before the disaster, as described further below in II.D.1.

The term "underserved communities" refers to populations sharing a particular characteristic, as well as geographic communities, that have been systematically denied a full opportunity to participate in aspects of economic, social, and civic life. Underserved communities that were economically distressed before the disaster include, but are not limited to, those areas that were designated as a Promise Zone, Opportunity Zone, a Neighborhood Revitalization Strategy Area, a tribal area, or those areas that meet at least one of the distress criteria established for the designation of an investment area of Community Development Financial Institution at 12 CFR 1805.201(b)(3)(ii)(D).

Grantees undertaking an economic revitalization activity must maintain supporting documentation to demonstrate how the grantee has prioritized underserved communities for purposes of its activities that support economic revitalization, as described below in II.D.1.

**II.D.1. Prioritizing economic revitalization assistance—alternative requirement.** When funding activities outlined in 24 CFR 570.203 and 570.204 and sections 105(a)(14), (15), and (17) of the HCDA, HUD is instituting an alternative requirement in addition to the other requirements in these provisions to require grantees to prioritize assistance to disaster-impacted businesses that serve underserved communities and spur economic opportunity for underserved communities that were economically distressed before the disaster.

**II.D.2. National objective documentation for activities that support economic revitalization.** 24 CFR 570.208(a)(4)(i)&(ii), 24 CFR 570.483(b)(4)(i)&(ii), 24 CFR 570.506(b)(5)&(6), and 24 CFR 1003.208(d) are waived to allow the grantees under the Consolidated Notice to identify the LMI jobs benefit by documenting, for each person employed, the name of the business, type of job, and the annual wages or salary of the job. HUD will consider the person income-qualified if the annual wages or salary of the job is at or under the HUD-established income limit for a one-person family. This method replaces the standard CDBG requirement—in which grantees must review the annual wages or salary of a job in comparison to the person's total household income and size (*i.e.*, the number of persons). Thus, this method streamlines the documentation process by allowing the collection of wage data for each position created or retained from the assisted businesses, rather than from each individual household.

**II.D.3. Public benefit for activities that support economic revitalization.** When applicable, the public benefit provisions set standards for individual economic development activities (such as a single loan to a business) and for the aggregate of all economic development activities. Economic

development activities support economic revitalization. Currently, public benefit standards limit the amount of CDBG assistance per job retained or created, or the amount of CDBG assistance per LMI person to whom goods or services are provided by the activity. These dollar thresholds can impede recovery by limiting the amount of assistance the grantee may provide to a critical activity.

HUD waives the public benefit standards at 42 U.S.C. 5305(e)(3), 24 CFR 570.482(f)(1), (2), (3), (4)(i), (5), and (6), and 570.209(b)(1), (2), (3)(i), (4), and 24 CFR 1003.302(c) for all economic development activities. Paragraph (g) of 24 CFR 570.482 and paragraph (c) and (d) under 570.209 are also waived to the extent these provisions are related to public benefit. However, grantees that choose to take advantage of this waiver in lieu of complying with public benefit standards under the existing regulatory requirements shall be subject to the following condition: Grantees shall collect and maintain documentation in the project file on the creation and retention of total jobs; the number of jobs within appropriate salary ranges, as determined by the grantee; the average amount of assistance provided per job, by activity or program; and the types of jobs. Additionally, grantees shall report the total number of jobs created and retained and the applicable national objective in the DRGR system.

**II.D.4. Clarifying note on Section 3 worker eligibility and documentation requirements.** Section 3 of the Housing and Urban Development Act of 1968 (12 U.S.C. 1701u) (Section 3) applies to CDBG-DR activities that are Section 3 projects, as defined at 24 CFR 75.3(a)(2). The purpose of Section 3 is to ensure that economic opportunities, most importantly employment, generated by certain HUD financial assistance shall be directed to low- and very low-income persons, particularly those who are recipients of government assistance for housing or residents of the community in which the Federal assistance is spent. CDBG-DR grantees are directed to HUD's guidance published in CPD Notice 2021-09, "Section 3 of the Housing and Urban Development Act of 1968, as amended by the Housing and Community Development Act of 1992, final rule requirements for CDBG, CDBG-CV, CDBG-DR, CDBG-Mitigation (CDBG-MIT), NSP, Section 108, and RHP projects," as amended (<https://www.hud.gov/sites/dfiles/OCHCO/documents/2021-09cpdn.pdf>). All direct recipients of CDBG-DR funding must report Section 3 information through the DRGR system.

**II.D.5. Waiver and modification of the job relocation clause to permit assistance to help a business return.** CDBG requirements prevent program participants from providing assistance to a business to relocate from one labor market area to another if the relocation is likely to result in a significant loss of jobs in the labor market from which the business moved. This prohibition can be a critical barrier to reestablishing and rebuilding a displaced employment base after a major disaster. Therefore, 42 U.S.C. 5305(h), 24 CFR 570.210, 24 CFR 570.482(h), and 24 CFR 1003.209, are waived to allow a grantee to provide assistance to any business that was

operating in the disaster-declared labor market area before the incident date of the applicable disaster and has since moved, in whole or in part, from the affected area to another state or to another labor market area within the same state to continue business.

**II.D.6. Underwriting.** Notwithstanding section 105(e)(1) of the HCDA, no CDBG-DR funds may be provided to a for-profit entity for an economic development project under section 105(a)(17) of the HCDA unless such project has been evaluated and selected in accordance with guidelines developed by HUD pursuant to section 105(e)(2) of the HCDA for evaluating and selecting economic development projects. Grantees and their subrecipients are required to comply with the underwriting guidelines in Appendix A to 24 CFR part 570 if they are using grant funds to provide assistance to a for-profit entity for an economic development project under section 105(a)(17) of the HCDA. The underwriting guidelines are found at Appendix A of 24 CFR part 570.

**II.D.7. Limitation on use of funds for eminent domain.** CDBG-DR funds may not be used to support any Federal, state, or local projects that seek to use the power of eminent domain, unless eminent domain is employed only for a public use. For purposes of this paragraph, public use shall not be construed to include economic development that primarily benefits private entities. The following shall be considered a public use for the purposes of eminent domain: Any use of funds for (1) mass transit, railroad, airport, seaport, or highway projects; (2) utility projects that benefit or serve the general public, including energy related, communication-related, water related, and wastewater-related infrastructure; (3) other structures designated for use by the general public or which have other common-carrier or public-utility functions that serve the general public and are subject to regulation and oversight by the government; and (4) projects for the removal of an immediate threat to public health and safety, including the removal of a brownfield as defined in the Small Business Liability Relief and Brownfields Revitalization Act (Pub. L. 107-118).

### III. Grant Administration

#### III.A. Pre-Award Evaluation of Management and Oversight of Funds

**III.A.1. Certification of financial controls and procurement processes, and adequate procedures for proper grant management.** Appropriations acts require that the Secretary certify that the grantee has in place proficient financial controls and procurement processes and has established adequate procedures to prevent any duplication of benefits as defined by section 312 of the Stafford Act, 42 U.S.C. 5155, to ensure timely expenditure of funds, to maintain a comprehensive website regarding all disaster recovery activities assisted with these funds, and to detect and prevent waste, fraud, and abuse of funds.

**III.A.1.a. Documentation requirements.** To enable the Secretary to make this certification, each grantee must submit to HUD the certification documentation listed below. This information must be submitted within 60 days of the applicability date of the

Allocation Announcement Notice, or with the grantee's submission of its action plan in DRGR as described in section III.C.1, whichever date is earlier. If required by appropriations acts, grant agreements will not be executed until the Secretary has issued a certification for the grantee. For each of the items (1) through (6) below (collectively referred to as the "Financial Management and Grant Compliance Certification Requirements") the grantee must certify to the accuracy of its submission when submitting the Financial Management and Grant Compliance Certification Checklist (the "Certification Checklist"). The Certification Checklist is a document that incorporates all of the Financial Management and Grant Compliance Certification Requirements. Not all of the requirements in (1) through (6) below are appropriate or applicable to Indian tribes. Therefore, Indian tribes that receive an allocation directly from HUD may request an alternative method to document support for the Secretary's certification.

(1) Proficient financial management controls. A grantee has proficient financial management controls if each of the following criteria is satisfied:

(a) The grantee agency administering this grant submits its most recent single audit and consolidated annual financial report (CAFR), which in HUD's determination indicates that the grantee has no material weaknesses, deficiencies, or concerns that HUD considers to be relevant to the financial management of CDBG, CDBG-DR, or CDBG-MIT funds. If the single audit or CAFR identified weaknesses or deficiencies, the grantee must provide documentation satisfactory to HUD showing how those weaknesses have been removed or are being addressed.

(b) The grantee has completed and submitted the certification documentation required in the applicable Certification Checklist. The grantee's documentation must demonstrate that the standards meet the requirements in the Consolidated Notice and the Certification Checklist.

(2) Each grantee must provide HUD its procurement processes for review, so HUD may evaluate the grantee's processes to determine that they are based on principles of full and open competition. A grantee's procurement processes must comply with the procurement requirements at section IV.B.

(a) A state grantee has proficient procurement processes if HUD determines that its processes uphold the principles of full and open competition and include an evaluation of the cost or price of the product or service, and if its procurement processes reflect that it:

(i) Adopted 2 CFR 200.318 through 200.327;

(ii) follows its own state procurement policies and procedures and establishes requirements for procurement processes for local governments and subrecipients based on full and open competition pursuant to 24 CFR 570.489(g), and the requirements for the state, its local governments, and subrecipients include evaluation of the cost or price of the product or service; or

(iii) adopted 2 CFR 200.317, meaning that it will follow its own state procurement

processes and evaluate the cost or price of the product or service, but impose 2 CFR 200.318 through 200.327 on its subrecipients.

(b) A local government grantee has proficient procurement processes if the processes are consistent with the specific applicable procurement standards identified in 2 CFR 200.318 through 200.327. When the grantee provides a copy of its procurement processes, it must indicate the sections that incorporate these provisions.

(c) An Indian tribe grantee has proficient procurement processes if its procurement standards are consistent with procurement requirements in 2 CFR part 200 imposed by 24 CFR 1003.501, and additional procurement requirements in 1003.509(e) and 1003.510.

(3) Duplication of benefits. A grantee has adequate policies and procedures to prevent the duplication of benefits (DOB) if the grantee submits and identifies a uniform process that reflects the requirements in section IV.A of the Consolidated Notice, including:

(a) Determining all disaster assistance received by the grantee or applicant and all reasonably identifiable financial assistance available to the grantee or applicant, as applicable, before committing funds or awarding assistance;

(b) determining a grantee's or an applicant's unmet need(s) for CDBG-DR assistance before committing funds or awarding assistance; and

(c) requiring beneficiaries to enter into a signed agreement to repay any duplicative assistance if they later receive additional assistance for the same purpose for which the CDBG-DR award was provided. The grantee must identify a method to monitor compliance with the agreement for a reasonable period (*i.e.*, a time period commensurate with risk) and must articulate this method in its policies and procedures, including the basis for the period during which the grantee will monitor compliance. This agreement must also include the following language: "Warning: Any person who knowingly makes a false claim or statement to HUD or causes another to do so may be subject to civil or criminal penalties under 18 U.S.C. 2, 287, 1001 and 31 U.S.C. 3729."

Policies and procedures of the grantee submitted to support the certification must provide that before the award of assistance, the grantee will use the best, most recent available data from FEMA, the Small Business Administration (SBA), insurers, and any other sources of local, state, and Federal sources of funding to prevent the duplication of benefits.

(4) Timely expenditures. A grantee has adequate policies and procedures to determine timely expenditures if it submits policies and procedures that indicate the following to HUD: How it will track and document expenditures of the grantee and its subrecipients (both actual and projected reported in performance reports); how it will account for and manage program income; how it will reprogram funds in a timely manner for activities that are stalled; and how it will project expenditures of all CDBG-DR funds within the period provided for in section V.A.

(5) Comprehensive disaster recovery website. A grantee has adequate policies and procedures to maintain a comprehensive accessible website if it submits policies and procedures indicating to HUD that the grantee will have a separate web page dedicated to its disaster recovery activities assisted with CDBG-DR funds that includes the information described at section III.D.1.d.–e. The procedures must also indicate the frequency of website updates. At minimum, grantees must update their website quarterly.

(6) Procedures to detect and prevent fraud, waste, and abuse. A grantee has adequate procedures to detect and prevent fraud, waste, and abuse if it submits procedures that indicate:

(a) How the grantee will verify the accuracy of information provided by applicants;

(b) the criteria to be used to evaluate the capacity of potential subrecipients;

(c) the frequency with which the grantee will monitor other agencies of the grantee that will administer CDBG-DR funds, and how it will monitor subrecipients, contractors, and other program participants, and why monitoring is to be conducted and which items are to be monitored;

(d) it has or will hire an internal auditor that provides both programmatic and financial oversight of grantee activities, and has adopted policies that describes the auditor's role in detecting fraud, waste, and abuse, which policies must be submitted to HUD;

(e) (i) for states or grantees subject to the same requirements as states, a written standard of conduct and conflicts of interest policy that complies with the requirements of 24 CFR 570.489(g) and (h) and subparagraph III.A.1.a(2)(a) of the Consolidated Notice, which policy includes the process for promptly identifying and addressing such conflicts;

(ii) for units of general local government or grantees subject to the same requirements as units of general local government, a written standard of conduct and conflicts of interest policy that complies with 24 CFR 570.611 and 2 CFR 200.318, as applicable, which includes the process for promptly identifying and addressing such conflicts;

(iii) for Indian tribes, a written standard of conduct and conflicts of interest policy that complies with 24 CFR 1003.606, as applicable; and

(f) it assists in investigating and taking action when fraud occurs within the grantee's CDBG-DR activities and/or programs. All grantees receiving CDBG-DR funds for the first time shall attend and require subrecipients to attend fraud related training provided by HUD OIG, when offered, to assist in the proper management of CDBG-DR grant funds. Instances of fraud, waste, and abuse should be referred to the HUD OIG Fraud Hotline (phone: 1-800-347-3735 or email: [hotline@hudoig.gov](mailto:hotline@hudoig.gov)).

Following a disaster, property owners and renters are frequently the targets of persons fraudulently posing as government employees, creditors, mortgage servicers, insurance adjusters, and contractors. The grantee's procedures must address how the

grantee will make CDBG-DR beneficiaries aware of the risks of contractor fraud and other potentially fraudulent activity that can occur in communities recovering from a disaster. Grantees must provide CDBG-DR beneficiaries with information that raises awareness of possible fraudulent activity, how the fraud can be avoided, and what local or state agencies to contact to take action and protect the grantee and beneficiary investment. The grantee's procedures must address the steps it will take to assist a CDBG-DR beneficiary if the beneficiary experiences contractor or other fraud. If the beneficiary is eligible for additional assistance as a result of the fraudulent activity and the creation of remaining unmet need, the procedures must also address what steps the grantee will follow to provide the additional assistance.

III.A.1.b. *Relying on prior submissions—financial management and grant compliance certification requirements.* This section only applies once a grantee has received a CDBG-DR grant through an Allocation Announcement Notice that makes the Consolidated Notice applicable. After that original grant, if a CDBG-DR grantee is awarded a subsequent CDBG-DR grant, HUD will rely on the grantee's prior submissions provided in response to the Financial Management and Grant Compliance Certification Requirements in the Consolidated Notice. HUD will continue to monitor the grantee's submissions and updates made to policies and procedures during the normal course of business. The grantee must notify HUD of any substantial changes made to these submissions.

If a CDBG-DR grantee is awarded a subsequent CDBG-DR grant, and it has been more than three years since the executed grant agreement for the original CDBG-DR grant or a subsequent grant is equal to or greater than ten times the amount of the original CDBG-DR grant, grantees must update and resubmit the documentation required by paragraph III.A.1.a. with the completed Certification Checklist to enable the Secretary to certify that the grantee has in place proficient financial controls and procurement processes, and adequate procedures for proper grant management. However, the Secretary may require any CDBG-DR grantee to update and resubmit the documentation required by paragraph III.A.1.a., if there is good cause to require it.

III.A.2. *Implementation plan.* HUD requires each grantee to demonstrate that it has sufficient capacity to manage the CDBG-DR funds and the associated risks. Grantees must evidence their management capacity through their implementation plan submissions. These submissions must meet the criteria below and must be submitted within 120 days of the applicability date of the governing Allocation Announcement Notice or with the grantee's submission of its action plan, whichever is earlier, unless the grantee has requested, and HUD has approved an extension of the submission deadline.

III.A.2.a. To enable HUD to assess risk as described in 2 CFR 200.206, the grantee will submit an implementation plan to HUD. The implementation plan must describe the grantee's capacity to carry out the recovery



and how it will address any capacity gaps. HUD will determine that the grantee has sufficient management capacity to adequately reduce risk if the grantee submits implementation plan documentation that addresses (1) through (3) below:

(1) Capacity assessment. The grantee identifies the lead agency responsible for implementation of the CDBG-DR award and indicates that the head of that agency will report directly to the chief executive officer of the jurisdiction. The grantee has conducted an assessment of its capacity to carry out CDBG-DR recovery efforts and has developed a timeline with milestones describing when and how the grantee will address all capacity gaps that are identified. The assessment must include a list of any open CDBG-DR findings and an update on the corrective actions undertaken to address each finding.

(2) Staffing. The grantee must submit an organizational chart of its department or division and must also provide a table that clearly indicates which personnel or organizational unit will be responsible for each of the Financial Management and Grant Compliance Certification Requirements identified in section III.A.1.a. along with staff contact information, if available (*i.e.*, personnel responsible for conducting DOB analysis, timely expenditure, website management, monitoring and compliance, and financial management). The grantee must also submit documentation demonstrating that it has assessed staff capacity and identified positions for the purpose of: Case management in proportion to the applicant population; program managers who will be assigned responsibility for each primary recovery area; staff who have demonstrated experience in housing, infrastructure (as applicable), and economic revitalization (as applicable); staff responsible for procurement/contract management, regulations implementing Section 3 of the Housing and Urban Development Act of 1968, as amended (24 CFR part 75) (Section 3), fair housing compliance, and environmental compliance. An adequate plan must also demonstrate that the internal auditor and responsible audit staff report independently to the chief elected or executive officer or board of the governing body of any designated administering entity.

The grantee's implementation plan must describe how it will provide technical assistance for any personnel that are not employed by the grantee at the time of action plan submission, and to fill gaps in knowledge or technical expertise required for successful and timely recovery. State grantees must also include how it plans to provide technical assistance to subgrantees and subrecipients, including units of general local government.

(3) Internal and interagency coordination. The grantee's plan must describe how it will ensure effective communication between different departments and divisions within the grantee's organizational structure that are involved in CDBG-DR-funded recovery efforts, mitigation efforts, and environmental review requirements, as appropriate; between its lead agency and subrecipients responsible for implementing the grantee's action plan;

and with other local and regional planning efforts to ensure consistency. The grantee's submissions must demonstrate how it will consult with other relevant government agencies, including the State Hazard Mitigation Officer (SHMO), State or local Disaster Recovery Coordinator, floodplain administrator, and any other state and local emergency management agencies, such as public health and environmental protection agencies, that have primary responsibility for the administration of FEMA or USACE funds.

III.A.2.b. *Relying on prior submissions—Implementation plan.* This section only applies once a grantee has received a CDBG-DR grant through an Allocation Announcement Notice that makes the Consolidated Notice applicable. After that original grant, if a CDBG-DR grantee is awarded a subsequent CDBG-DR grant, HUD will rely on the grantee's implementation plan submitted for its original CDBG-DR grant unless it has been more than three years since the executed grant agreement for the original CDBG-DR grant or the subsequent grant is equal to or greater than ten times the amount of its original CDBG-DR grant.

If a CDBG-DR grantee is awarded a subsequent CDBG-DR grant, and it has been more than three years since the executed grant agreement for its original CDBG-DR grant or a subsequent grant is equal to or greater than ten times the amount of the original CDBG-DR grant, the grantee is to update and resubmit its implementation plan to reflect any changes to its capacity, staffing, and coordination.

### III.B. Administration, Planning, and Financial Management

#### III.B.1. Grant administration and planning.

III.B.1.a. *Grantee responsibilities.* Each grantee shall administer its award in compliance with all applicable laws and regulations and shall be financially accountable for the use of all awarded funds. CDBG-DR grantees must comply with the recordkeeping requirements of 24 CFR 570.506 and 24 CFR 570.490, as amended by the Consolidated Notice waivers and alternative requirements. All grantees must maintain records of performance in DRGR, as described elsewhere in the Consolidated Notice.

III.B.1.b. *Grant administration cap.* Up to five percent of the grant (plus five percent of program income generated by the grant) can be used for administrative costs by the grantee, units of general local government, or subrecipients. Thus, the total of all costs classified as administrative for a CDBG-DR grant must be less than or equal to the five percent cap (plus five percent of program income generated by the grant). The cap for administrative costs is subject to the combined technical assistance and administrative cap for state grantees as discussed in section III.B.2.a.

III.B.1.c. *Use of funds for administrative costs across multiple grants.* The Additional Supplemental Appropriations for Disaster Relief Act, 2019 (Pub. L. 116–20) authorized special treatment for eligible administrative costs for grantees that received awards under Public Laws 114–113, 114–223, 114–254, 115–31, 115–56, 115–123, 115–254, 116–20,

or any future act. The Consolidated Notice permits grantees to use eligible administrative funds (up to five percent of each grant award plus up to five percent of program income generated by the grant) for the cost of administering any of these grants awarded under the identified Public Laws (including future Acts) without regard to the particular disaster appropriation from which such funds originated. To exercise this authority, the grantee must ensure that it has appropriate financial controls to guarantee that the amount of grant administration expenditures for each of the aforementioned grants will not exceed five percent of the total grant award for each grant (plus five percent of program income generated by the grant). The grantee must review and modify any financial management policies and procedures regarding the tracking and accounting of administration costs as necessary.

III.B.1.d. *Planning expenditures cap.* Both state and local government grantees are limited to spending a maximum of fifteen percent of their total grant amount on planning costs. Planning costs subject to the 15 percent cap are those defined in 42 U.S.C. 5305(a)(12) and more broadly in 24 CFR 570.205.

#### III.B.2. State grantees only.

III.B.2.a. *Combined technical assistance and administrative cap (state grantees only).* The provisions of 42 U.S.C. 5306(d) and 24 CFR 570.489(a)(1)(i) and (iii), and 24 CFR 570.489(a)(2) shall not apply to the extent that they cap administration and technical assistance expenditures, limit a state's ability to charge a nominal application fee for grant applications for activities the state carries out directly, and require a dollar-for-dollar match of state funds for administrative costs exceeding \$100,000. 42 U.S.C. 5306(d)(5) and (6) are waived and replaced with the alternative requirement that the aggregate total for administrative and technical assistance expenditures must not exceed five percent of the grant, plus five percent of program income generated by the grant.

III.B.2.b. *Planning-only activities (state grantees only).* The State CDBG Program requires that, for planning-only grants, local government grant recipients must document that the use of funds meets a national objective. In the CDBG Entitlement Program, these more general planning activities are presumed to meet a national objective under the requirements at 24 CFR 570.208(d)(4). HUD notes that almost all effective recoveries in the past have relied on some form of area-wide or comprehensive planning activity to guide overall redevelopment independent of the ultimate source of implementation funds. To assist state grantees, HUD is waiving the requirements at 24 CFR 570.483(b)(5) and (c)(3), which limit the circumstances under which the planning activity can meet a low- and moderate-income or slum-and-bligh national objective. Instead, as an alternative requirement, 24 CFR 570.208(d)(4) applies to states when funding disaster recovery-assisted, planning-only grants, or when directly administering planning activities that guide disaster recovery. In addition, 42 U.S.C. 5305(a)(12) is waived to the extent necessary so the types of planning activities

that states may fund or undertake are expanded to be consistent with those of CDBG Entitlement grantees identified at 24 CFR 570.205.

III.B.2.c. *Direct grant administration and means of carrying out eligible activities (state grantees only)*. Requirements at 42 U.S.C. 5306(d) are waived to allow a state to use its disaster recovery grant allocation directly to carry out state-administered activities eligible under the Consolidated Notice, rather than distribute all funds to local governments. Pursuant to this waiver and alternative requirement, the standard at 24 CFR 570.480(c) and the provisions at 42 U.S.C. 5304(e)(2) will also include activities that the state carries out directly. Activities eligible under the Consolidated Notice may be carried out by a state, subject to state law and consistent with the requirement of 24 CFR 570.200(f), through its employees, through procurement contracts, or through assistance provided under agreements with subrecipients. State grantees continue to be responsible for civil rights, labor standards, and environmental protection requirements, for compliance with 24 CFR 570.489(g) and (h), and subparagraph III.A.1.a.(2)(a) of the Consolidated Notice relating to conflicts of interest, and for compliance with 24 CFR 570.489(m) relating to monitoring and management of subrecipients.

A state grantee may also carry out activities in tribal areas. A state must coordinate with the Indian tribe with jurisdiction over the tribal area when providing CDBG-DR assistance to beneficiaries in tribal areas. State grantees carrying out projects in tribal areas, either directly or through its employees, through procurement contracts, or through assistance provided under agreements with subrecipients, must obtain the consent of the Indian tribe with jurisdiction over the tribal area to allow the state grantee to carry out or to fund CDBG-DR projects in the area.

III.B.2.d. *Waiver and alternative requirement for distribution to CDBG metropolitan cities and urban counties (state grantees only)*. 42 U.S.C. 5302(a)(7) (definition of “nonentitlement area”) and related provisions of 24 CFR part 570, including 24 CFR 570.480, are waived to permit state grantees to distribute CDBG-DR funds to units of local government and Indian tribes.

III.B.2.e. *Use of subrecipients (state grantees only)*. Paragraph III.B.2.c. provides a waiver and alternative requirement that a state may carry out activities directly, including through assistance provided under agreements with subrecipients. Therefore, when states carry out activities directly through subrecipients, the following alternative requirements apply: The state is subject to the definition of subrecipients at 24 CFR 570.500(c) and must adhere to the requirements for agreements with subrecipients at 24 CFR 570.503. Additionally, 24 CFR 570.503(b)(4) is modified to require the subrecipient to comply with applicable uniform requirements, as described in 24 CFR 570.502, except that the subrecipient shall follow procurement requirements imposed by the state in accordance with subparagraph

III.A.1.a.(2) of the Consolidated Notice. When 24 CFR 570.503 applies, notwithstanding 24 CFR 570.503(b)(5)(i), units of general local government that are subrecipients are defined as recipients under 24 CFR part 58 and are therefore responsible entities that assume environmental review responsibilities, as described in III.F.5. Grantees are reminded that they are responsible for providing on-going oversight and monitoring of subrecipients and are ultimately responsible for subrecipient compliance with all CDBG-DR requirements.

III.B.2.f. *Recordkeeping (state grantees only)*. When a state carries out activities directly, 24 CFR 570.490(b) is waived and the following alternative provision shall apply: A state grantee shall establish and maintain such records as may be necessary to facilitate review and audit by HUD of the state’s administration of CDBG-DR funds, under 24 CFR 570.493 and reviews and audits by the state under III.B.2.h. Consistent with applicable statutes, regulations, waivers and alternative requirements, and other Federal requirements, the content of records maintained by the state shall be sufficient to: (a) Enable HUD to make the applicable determinations described at 24 CFR 570.493; (b) make compliance determinations for activities carried out directly by the state; and (c) show how activities funded are consistent with the descriptions of activities proposed for funding in the action plan and/or DRGR system. For fair housing and equal opportunity purposes, and as applicable, such records shall include data on the racial, ethnic, and gender characteristics of persons who are applicants for, participants in, or beneficiaries of the program.

III.B.2.g. *Change of use of real property (state grantees only)*. This alternative requirement conforms the change of use of real property rule to the waiver allowing a state to carry out activities directly. For purposes of these grants, all references to “unit of general local government” in 24 CFR 570.489(j), shall be read as “state, local governments, or Indian tribes (either as subrecipients or through a method of distribution), or other state subrecipient.”

III.B.2.h. *Responsibility for review and handling of noncompliance (state grantees only)*. This change is in conformance with the waiver allowing a state to carry out activities directly. 24 CFR 570.492 is waived, and the following alternative requirement applies for any state receiving a direct award: The state shall make reviews and audits, including on-site reviews of any local governments or Indian tribes (either as subrecipients or through a method of distribution) designated public agencies, and other subrecipients, as may be necessary or appropriate to meet the requirements of section 104(e)(2) of the HCDA, as amended, and as modified by the Consolidated Notice. In the case of noncompliance with these requirements, the state shall take such actions as may be appropriate to prevent a continuance of the deficiency, mitigate any adverse effects or consequences, and prevent a recurrence. The state shall establish remedies for noncompliance by any subrecipients, designated public agencies, or local governments.

III.B.2.i. *Consultation (state grantees only)*. Currently, the HCDA and regulations require a state grantee to consult with affected local governments in nonentitlement areas of the state in determining the state’s proposed method of distribution. HUD is waiving 42 U.S.C. 5306(d)(2)(C)(iv), 42 U.S.C. 5306(d)(2)(D), 24 CFR 91.325(b)(2), and 24 CFR 91.110, and imposing an alternative requirement that states receiving an allocation of CDBG-DR funds consult with all disaster-affected local governments (including any CDBG-entitlement grantees), Indian tribes, and any public housing authorities in determining the use of funds. This approach ensures that a state grantee sufficiently assesses the recovery needs of all areas affected by the disaster.

### III.C. Action Plan for Disaster Recovery Waiver and Alternative Requirement

Requirements for CDBG actions plans, located at 42 U.S.C. 5304(a)(1), 42 U.S.C. 5304(m), 42 U.S.C. 5306(a)(1), 42 U.S.C. 5306(d)(2)(C)(iii), 42 U.S.C. 12705(a)(2), and 24 CFR 91.220 and 91.320, are waived for CDBG-DR grants. Instead, grantees must submit to HUD an action plan for disaster recovery which will describe programs and activities that conform to applicable requirements as specified in the Consolidated Notice and the applicable Allocation Announcement Notice. HUD will monitor the grantee’s actions and use of funds for consistency with the plan, as well as meeting the performance and timeliness objectives therein. The Secretary will disapprove all action plans that are substantially incomplete if it is determined that the plan does not satisfy all of the required elements identified in the Consolidated Notice and the applicable Allocation Announcement Notice.

III.C.1. *Action plan*. The grantee’s action plan must identify the use of all funds—including criteria for eligibility and how the uses address long-term recovery needs, restoration of infrastructure and housing, economic revitalization, and the incorporation of mitigation measures in the MID areas. HUD created the Public Action Plan in DRGR which is a function that allows grantees to develop and submit their action plans for disaster recovery directly into DRGR. Grantees must use HUD’s Public Action Plan in DRGR to develop all CDBG-DR action plans and substantial amendments submitted to HUD for approval. The Public Action Plan is different from the DRGR Action Plan, which is a comprehensive description of projects and activities in DRGR.

The grantee must describe the steps it will follow to make the action plan, substantial amendments, performance reports, and other relevant program materials available in a form accessible to persons with disabilities and those with limited English proficiency (LEP). All grantees must include sufficient information in its action plan so that all interested parties will be able to understand and comment on the action plan. The action plan (and subsequent amendments) must include a single chart or table that illustrates, at the most practical level, how all funds are budgeted (e.g., by program, subrecipient, grantee-administered activity, or other

category). The grantee must certify, as required by section III.F.7., that activities to be undertaken with CDBG–DR funds are consistent with its action plan.

The action plan must contain:

III.C.1.a. *An impact and unmet needs assessment.* Each grantee must develop an impact and unmet needs assessment to understand the type and location of community needs and to target limited resources to those areas with the greatest need. CDBG–DR grantees must conduct an impact and unmet needs assessment to inform the use of the grant. Grantees must cite data sources in the impact and unmet needs assessment. At a minimum, the impact and unmet needs assessment must:

- Evaluate all aspects of recovery including housing (interim and permanent, owner and rental, single family and multifamily, affordable and market rate, and housing to meet the needs of persons who were experiencing homelessness pre-disaster), infrastructure, and economic revitalization needs, while also incorporating mitigation needs into activities that support recovery as required in section II.A.2.;

- Estimate unmet needs to ensure CDBG–DR funds meet needs that are not likely to be addressed by other sources of funds by accounting for the various forms of assistance available to, or likely to be available to, affected communities (e.g., projected FEMA funds) and individuals (e.g., estimated insurance) and, using the most recent available data, estimating the portion of need unlikely to be addressed by insurance proceeds, other Federal assistance, or any other funding sources;

- Assess whether public services (e.g., housing counseling, legal advice and representation, job training, mental health, and general health services) are necessary to complement activities intended to address housing, infrastructure, and economic revitalization and how those services would need to be made accessible to individuals with disabilities including, but not limited to, mobility, sensory, developmental, emotional, cognitive, and other impairments;
- Describe the extent to which expenditures for planning activities, including the determination of land use goals and policies, will benefit the HUD-identified MID areas, as described in section II.A.3.;
- Describe disaster impacts geographically by type at the lowest level practicable (e.g., county/parish level or lower if available for states, and neighborhood or census tract level for cities); and

- Take into account the costs and benefits of incorporating hazard mitigation measures to protect against the specific identified impacts of future extreme weather events and other natural hazards. This analysis should factor in historical and projected data on risk that incorporates best available science (e.g., the most recent National Climate Assessment).

Disaster recovery needs evolve over time and grantees must amend the impact and unmet needs assessment and action plan as additional needs are identified and additional resources become available. At a minimum, grantees must revisit and update the impact and unmet needs assessment

when moving funds from one program to another through a substantial amendment.

III.C.1.b. *Connection of programs and projects to unmet needs.* The grantee must describe the connection between identified unmet needs and the allocation of CDBG–DR resources. The plan must provide a clear connection between a grantee's impact and unmet needs assessment and its proposed programs and projects in the MID areas (or outside in connection to the MID areas as described in section II.A.3). Such description must demonstrate a reasonably proportionate allocation of resources relative to areas and categories (i.e., housing, economic revitalization, and infrastructure) of greatest need identified in the grantee's impact and unmet needs assessment or provide an acceptable justification for a disproportional allocation, while also incorporating hazard mitigation measures to reduce the impacts of recurring natural disasters and the long-term impacts of climate change. Grantee action plans may provide for the allocation of funds for administration and planning activities and for public service activities, subject to the caps on such activities as described in the Consolidated Notice.

III.C.1.c. *Public housing, affordable rental housing, and housing for vulnerable populations.* Each grantee must include a description of how it has analyzed, identified, and will address (with CDBG–DR or other sources) the disaster-related rehabilitation, reconstruction, and new construction needs in the MID-area of the types of housing described below. Specifically, a grantee must assess and describe how it will address unmet needs in the following types of housing, subject to the applicable HUD program requirements: Public housing, affordable rental housing (including both subsidized and market rate affordable housing), and housing for vulnerable populations (See Section III.C.1.c.iii below), including emergency shelters and permanent housing for persons experiencing homelessness, in the areas affected by the disaster. Grantees must coordinate with local public housing authorities (PHA) in the MID areas to ensure that the grantee's representation in the action plan reflects the input of those entities as well as coordinating with State Housing Finance agencies to make sure that all funding sources that are available and opportunities for leverage are noted in the action plan.

(i) *Public housing:* Describe unmet public housing needs of each disaster-impacted PHA within its jurisdiction, if applicable. The grantee must work directly with impacted PHAs in identifying necessary and reasonable costs and ensuring that adequate funding from all available sources is dedicated to addressing the unmet needs of damaged public housing (e.g., FEMA, insurance, and funds available from programs administered by HUD's Office of Public and Indian Housing).

(ii) *Affordable rental housing:* Describe unmet affordable rental housing needs for LMI households as a result of the disaster or exacerbated by the disaster, including private market units receiving project-based rental assistance or with tenants that participate in

the Section 8 Housing Choice Voucher Program, and any other housing that is assisted under a HUD program in the MID areas. Identify funding to specifically address these unmet needs for affordable rental housing to LMI households. If a grantee is proposing an allocation of CDBG–DR funds for affordable rental housing needs, the action plan must, at a minimum, meet the requirements described in II.B.3.

(iii) *Housing for vulnerable populations:* Describe how CDBG–DR or other funding sources available will promote housing for vulnerable populations, as defined in section III.C.1.d., in the MID area, including how it plans to address: (1) Transitional housing, including emergency shelters and housing for persons experiencing homelessness, permanent supportive housing, and permanent housing needs of individuals and families (including subpopulations) that are experiencing or at risk of experiencing homelessness; (2) the prevention of low-income individuals and families with children (especially those with incomes below thirty percent of the area median) from becoming homeless; (3) the special needs of persons who are not experiencing homelessness but require supportive housing (i.e., elderly, frail elderly, persons with disabilities (mental, physical, developmental, etc.), victims of domestic violence, persons with alcohol or other substance-use disorder, persons with HIV/AIDS and their families, and public housing residents, as identified in 24 CFR 91.315(e)).

III.C.1.d. *Fair housing, civil rights data, and advancing equity.* The grantee must use its CDBG–DR funds in a manner that complies with its fair housing and nondiscrimination obligations, including title VI of the Civil Rights Act of 1964, 42 U.S.C. 2000d *et seq.*, the Fair Housing Act, 42 U.S.C. 3601–19, Section 504 of the Rehabilitation Act of 1973, 29 U.S.C. 794, the Americans with Disabilities Act of 1990, 42 U.S.C. 12131 *et seq.*, and Section 109 of the HCDA, 42 U.S.C. 5309. To ensure that the activities performed in connection with the action plan will comply with these requirements, the grantee must provide an assessment of whether its planned use of CDBG–DR funds will have an unjustified discriminatory effect on or failure to benefit racial and ethnic minorities in proportion to their communities' needs, particularly in racially and ethnically concentrated areas of poverty, and how it will address the recovery needs of impacted individuals with disabilities.

Grantees should also consider the impact of their planned use of CDBG–DR funds on other protected class groups under fair housing and civil rights laws, vulnerable populations, and other historically underserved communities. For purposes of the Consolidated Notice, HUD defines vulnerable populations as a group or community whose circumstances present barriers to obtaining or understanding information or accessing resources. In the action plan, grantees should identify those populations (i.e., which protected class, vulnerable population, and historically underserved groups were considered) and how those groups can be expected to benefit from the activities set forth in the plan

consistent with the civil rights requirements set forth above.

To perform such an assessment, grantees must include data for the HUD-identified and grantee-identified MID areas that identifies the following information, as it is available:

- Racial and ethnic make-up of the population, including relevant sub-populations depending on activities and programs outlined in the plan (this would include renters and homeowners if eligibility is dependent on housing tenure) and the specific sub-geographies in the MID areas in which those programs and activities will be carried out;

- LEP populations, including number and percentage of each identified group;

- Number and percentage of persons with disabilities;

- Number and percentage of persons belonging to Federally protected classes under the Fair Housing Act (race, color, national origin, religion, sex—which includes sexual orientation and gender identity—familial status, and disability) and other vulnerable populations as determined by the grantee;

- Indigenous populations and tribal communities, including number and percentage of each identified group;

- Racially and ethnically concentrated areas and concentrated areas of poverty; and
- Historically distressed and underserved communities;

Grantees must explain how the use of funds will reduce barriers that individuals may face when enrolling in and accessing CDBG-DR assistance, for example, barriers imposed by a lack of outreach to their community or by the lack of information in non-English languages or accessible formats for individuals with different types of disabilities.

Grantees are strongly encouraged to include examples of how their proposed allocations, selection criteria, and other actions can be expected to advance equity for protected class groups. Grantees are strongly encouraged to explain and provide examples of how their actions can be expected to advance the following objectives:

- Equitably benefit protected class groups in the MID areas, including racial and ethnic minorities, and sub geographies in the MID areas in which residents belonging to such groups are concentrated;

- To the extent consistent with purposes and uses of CDBG-DR funds, overcome prior disinvestment in infrastructure and public services for protected class groups, and areas in which residents belonging to such groups are concentrated, when addressing unmet needs;

- Enhance for individuals with disabilities in the MID areas (a) the accessibility of disaster preparedness, resilience, or recovery services, including the accessibility of evacuation services and shelters; (b) the provision of critical disaster-related information in accessible formats; and/or (c) the availability of integrated, accessible housing and supportive services.

Grantees must identify the proximity of natural and environmental hazards (*e.g.*, industrial corridors, sewage treatment facilities, waterways, EPA superfund sites,

brownfields, etc.) to affected populations in the MID area, including members of protected classes, vulnerable populations, and underserved communities and explore how CDBG-DR activities may mitigate environmental concerns and increase resilience among these populations to protect against the effects of extreme weather events and other natural hazards.

Grantees must also describe how their use of CDBG-DR funds is consistent with their obligation to affirmatively further fair housing. HUD regulations at 24 CFR 5.151 provide that affirmatively furthering fair housing means taking meaningful actions, in addition to combating discrimination, that overcome patterns of segregation and foster inclusive communities free from barriers that restrict access to opportunity based on protected characteristics. Specifically, affirmatively furthering fair housing means taking meaningful actions that, taken together, address significant disparities in housing needs and in access to opportunity, replacing segregated living patterns with truly integrated and balanced living patterns, transforming racially or ethnically concentrated areas of poverty into areas of opportunity, and fostering and maintaining compliance with civil rights and fair housing laws.

State and local government grantees must submit a certification to AFFH in accordance with 24 CFR 5.150, *et seq.* CDBG-DR grantees must also comply with the recordkeeping requirements of 24 CFR 570.506 and 24 CFR 570.490(b), as amended by the Consolidated Notice.

III.C.1.e. *Infrastructure.* In its action plan, each grantee must include a description of how it plans to meet the requirements of the Consolidated Notice, including how it will: Promote sound, sustainable long-term recovery planning as described in this section; adhere to the elevation requirements established in section II.C.2.; and coordinate with local and regional planning efforts as described in section III.B.2.i and III.D.1.a. All infrastructure investments must be designed and constructed to withstand chronic stresses and extreme events by identifying and implementing resilience performance metrics as described in section II.A.2.c.

If a grantee is allocating funds for infrastructure, its description must include:

- (1) How it will address the construction or rehabilitation of disaster-related systems (*e.g.*, storm water management systems) or other disaster-related community-based mitigation systems (*e.g.*, using FEMA's community lifelines). State grantees carrying out infrastructure activities must work with units of general local government and Indian tribes in the MID areas to identify the unmet needs and associated costs of needed disaster-related infrastructure improvements;
- (2) How mitigation measures and strategies to reduce natural hazard risks, including climate-related risks, will be integrated into rebuilding activities;

- (3) The extent to which CDBG-DR funded infrastructure activities will achieve objectives outlined in regionally or locally established plans and policies that are designed to reduce future risk to the jurisdiction;

- (4) How the grantee will evaluate the costs and benefits in selecting infrastructure projects to assist with CDBG-DR funds;

- (5) How the grantee will align infrastructure investments with other planned federal, state, or local capital improvements and infrastructure development efforts, and will work to foster the potential for additional infrastructure funding from multiple sources, including state and local capital improvement projects in planning, and the potential for private investment;

- (6) How the grantee will employ adaptable and reliable technologies to prevent premature obsolescence of infrastructure; and

- (7) How the grantee will invest in restoration of infrastructure and related long-term recovery needs within historically underserved communities that lacked adequate investments in housing, transportation, water, and wastewater infrastructure prior to the disaster.

III.C.1.f. *Minimize Displacement.* A description of how the grantee plans to minimize displacement of persons or entities, and assist any persons or entities displaced, and ensure accessibility needs of displaced persons with disabilities. Specifically, grantees must detail how they will meet the Residential Anti-displacement and Relocation Assistance Plan (RARAP) requirements in section IV.F.7. Grantees must indicate to HUD whether they will be amending an existing RARAP or creating a new RARAP specific to CDBG-DR. Grantees must meet the requirements related to the RARAP prior to implementing any activity with CDBG-DR grant funds, such as buyouts and other disaster recovery activities. Grantees must seek to minimize displacement or adverse impacts from displacement, consistent with the requirements of Section IV.F of the Consolidated Notice, Section 104(d) of the HCDA (42 U.S.C. 5304(d)) and implementing regulations at 24 CFR part 42, and 24 CFR 570.488 or 24 CFR 570.606, as applicable. Grantees must describe how they will plan and budget for relocation activities in the action plan.

III.C.1.g. *Allocation and award caps.* The grantee must provide a budget for the full amount of the allocation that is reasonably proportionate to its unmet needs (or provide an acceptable justification for disproportional allocation) and is consistent with the requirements to integrate hazard mitigation measures into all its programs and projects. The grantee shall provide a description of each disaster recovery program or activity to be funded, including the CDBG-DR eligible activities and national objectives associated with each program and the eligibility criteria for assistance. The grantee shall also describe the maximum amount of assistance (*i.e.*, award cap) available to a beneficiary under each of the grantee's disaster recovery programs. A grantee may find it necessary to provide exceptions on a case-by-case basis to the maximum amount of assistance and must describe the process it will use to make such exceptions in its action plan. At a minimum, each grantee must adopt policies and procedures that communicate how it will analyze the circumstances under which an

exception is needed and how it will demonstrate that the amount of assistance is necessary and reasonable. Each grantee must also indicate in its action plan that it will make exceptions to the maximum award amounts when necessary, to comply with federal accessibility standards or to reasonably accommodate a person with disabilities.

III.C.1.h. *Cost controls and warranties.* The grantee must provide a description of the standards to be established for construction contractors performing work in the jurisdiction and the mechanisms to be used by the grantee to assist beneficiaries in responding to contractor fraud, poor quality work, and associated issues. Grantees must require a warranty period post-construction with a formal notification to beneficiaries on a periodic basis (e.g., 6 months and one month before expiration date of the warranty). Each grantee must also describe its controls for assuring that construction costs are reasonable and consistent with market costs at the time and place of construction.

III.C.1.i. *Resilience planning.* Resilience is defined as a community's ability to minimize damage and recover quickly from extreme events and changing conditions, including natural hazard risks. At a minimum, the grantee's action plan must contain a description of how the grantee will: (a) Emphasize high quality design, durability, energy efficiency, sustainability, and mold resistance; (b) support adoption and enforcement of modern and/or resilient building codes that mitigate against natural hazard risks, including climate-related risks (e.g., sea level rise, high winds, storm surge, flooding, volcanic eruption, and wildfire risk, where appropriate and as may be identified in the jurisdiction's rating and identified weaknesses (if any) in building code adoption using FEMA's Nationwide Building Code Adoption Tracking (BCAT) portal), and provide for accessible building codes and standards, as applicable; (c) establish and support recovery efforts by funding feasible, cost-effective measures that will make communities more resilient against a future disaster; (d) make land-use decisions that reflect responsible and safe standards to reduce future natural hazard risks, e.g., by adopting or amending an open space management plan that reflects responsible floodplain and wetland management and takes into account continued sea level rise, if applicable, and (e) increase awareness of the hazards in their communities (including for members of protected classes, vulnerable populations, and underserved communities) through outreach to the MID areas.

While the purpose of CDBG-DR funds is to recover from a Presidentially declared disaster, integrating hazard mitigation and resilience planning with recovery efforts will promote a more resilient and sustainable long-term recovery. The action plan must include a description of how the grantee will promote sound, sustainable long-term recovery planning informed by a post-disaster evaluation of hazard risk, including climate-related natural hazards and the creation of resilience performance metrics as described in paragraph II.A.2.c. of the Consolidated Notice. This information

should be based on the history of FEMA and other federally-funded disaster mitigation efforts and, as appropriate, take into account projected increases in sea level, the frequency and intensity of extreme weather events, and worsening wildfires. Grantees must use the FEMA-approved Hazard Mitigation Plan (HMP), Community Wildfire Protection Plan (CWPP), or other resilience plans to inform the evaluation, and it should be referenced in the action plan.

III.C.2. *Additional action plan requirements for states.* For state grantees, the action plan must describe how the grantee will distribute grant funds, either through specific programs and projects the grantee will carry out directly (through employees, contractors, or through subrecipients), or through a method of distribution of funds to local governments and Indian tribes (as permitted by III.B.2.d.). The grantee shall describe how the method of distribution to local governments or Indian tribes, or programs/projects carried out directly, will result in long-term recovery from specific impacts of the disaster.

All states must include in their action plan the information outlined in (1) through (7) below (in addition to other information required by section III.C.). For states using a method of distribution, if some required information is unknown when the grantee is submitting its action plan to HUD (e.g., the list of programs or activities required by III.C.1.g. or the projected use of CDBG-DR funds by responsible entity as required by subparagraph (5) below), the grantee must update the action plan through a substantial amendment once the information is known. If necessary to comply with a statutory requirement that a grantee shall submit a plan detailing the proposed use of all funds prior to HUD's obligation of grant funds, HUD may obligate only a portion of grant funds until the substantial amendment providing the required information is submitted and approved by HUD.

(1) How the impact and unmet needs assessment informs funding determinations, including the rationale behind the decision(s) to provide funds to most impacted and distressed areas.

(2) When funds are subgranted to local governments or Indian tribes (either as subrecipients or through a method of distribution), all criteria used to allocate and award the funds including the relative importance of each criterion (including any priorities). If the criteria are unknown when the grantee is submitting the initial action plan to HUD, the grantee must update the action plan through a substantial amendment once the information is known. The substantial amendment must be submitted and approved before distributing the funds to a local government or Indian tribe.

(3) How the distribution and selection criteria will address disaster-related unmet needs in a manner that does not have an unjustified discriminatory effect based on race or other protected class and ensure the participation of minority residents and those belonging to other protected class groups in the MID areas. Such description should include an assessment of who may be expected to benefit, the timing of who will

be prioritized, and the amount or proportion of benefits expected to be received by different communities or groups (e.g., the proportion of benefits going to different locations within the MID or to homeowners versus renters).

(4) The threshold factors and recipient or beneficiary grant size limits that are to be applied.

(5) The projected uses for the CDBG-DR funds, by responsible entity, activity, and geographic area.

(6) For each proposed program and/or activity, its respective CDBG activity eligibility category (or categories), national objective(s), and what disaster-related impact is addressed, as described in section II.A.1.

(7) When applications are solicited for programs carried out directly, all criteria used to select applications for funding, including the relative importance of each criterion, and any eligibility requirements. If the criteria are unknown when the grantee is submitting the initial action plan to HUD, the grantee must update the action plan through a substantial amendment once the information is known. The substantial amendment must be submitted and approved before selecting applications.

III.C.3. *Additional action plan requirements for local governments.* For local governments grantees, the action plan shall describe specific programs and/or activities they will carry out. The action plan must also describe:

(1) How the impact and unmet needs assessment informs funding determinations, including the rationale behind the decision(s) to provide funds to most impacted and distressed areas.

(2) All criteria used to select applications (including any priorities), including the relative importance of each criterion, and any eligibility requirements. If the criteria are unknown when the grantee is submitting the initial action plan to HUD, the grantee must update the action plan through a substantial amendment once the information is known. The substantial amendment must be submitted and approved before selecting applications.

(3) How the distribution and selection criteria will address disaster-related unmet needs in a manner that does not have an unjustified discriminatory effect and ensures the participation of minority residents and those belonging to other protected class groups in the MID areas, including with regards to who may benefit, the timing of who will be prioritized, and the amount or proportion of benefits expected to be received by different communities or groups (e.g., the proportion of benefits going to different locations within the MID or to homeowners versus renters).

(4) The threshold factors and grant size limits that are to be applied.

(5) The projected uses for the CDBG-DR funds, by responsible entity, activity, and geographic area.

(6) For each proposed program and/or activity, its respective CDBG activity eligibility category (or categories), national objective(s), and what disaster-related impact is addressed, as described in section II.A.1. of the Consolidated Notice.

III.C.4. *Waiver of 45-day review period for CDBG-DR action plans to 60 days.* HUD may disapprove an action plan or substantial action plan amendment if it is incomplete. HUD works with grantees to resolve or provide additional information during the review period to avoid the need to disapprove an action plan or substantial action plan amendments. There are several issues related to the action plan as submitted that can be fully resolved via further discussion and revision during an extended review period, rather than through HUD disapproval of the plan, which in turn would require grantees to take additional time to revise and resubmit their respective plan. Therefore, the Secretary has determined that good cause exists and waives 24 CFR 91.500(a) to extend HUD's action plan review period from 45 days to 60 days.

The action plan (including SF-424 and certifications) must be submitted to HUD for review and approval using DRGR. By submitting required standard forms (that must be submitted with the action plan), the grantee is providing assurances that it will comply with statutory requirements, including, but not limited to civil rights requirements. Applicants and recipients are required to submit assurances of compliance with federal civil rights requirements. A grantee will use DRGR's upload function to include the SF 424 (including SF 424B and SF 424D, as applicable) and certifications with its action plan. Grantees receiving an allocation are required to submit an action plan within 120 days of the applicability date of the Allocation Announcement Notice, unless the grantee has requested, and HUD has approved an extension of the submission deadline. HUD will then review each action plan within 60 days from the date of receipt.

During its review, HUD typically provides grantees with comments on the submitted plan to avoid the need to disapprove an action plan and offers a grantee the opportunity to make updates to the action plan during the first forty-five days of HUD's initial sixty-day review period. If a grantee wants to make updates to the action plan, HUD will reject the Public Action Plan in DRGR to return the plan to the grantee. Then, once the grantee resubmits the plan, HUD reviews the revised plan within the initial sixty-day period. HUD is establishing an alternative process that offers a grantee the option to voluntarily provide a revised action plan, updated to respond to HUD's comments, no later than day forty-five in HUD's sixty-day review. A grantee is not required to participate in the revisions of the action plan during this time, but with the understanding that an action plan may be determined to be substantially incomplete. The Secretary may disapprove an action plan as substantially incomplete if HUD determines that the action plan does not meet the requirements of the Consolidated Notice and the applicable Allocation Announcement Notice.

III.C.5. *Obligation and expenditure of funds.* Once HUD approves the action plan and approves certifications if required by appropriations acts, it will then sign a grant agreement obligating allocated funds to the grantee. The grantee will continue the action

plan process in DRGR to draw funds (see section V.C.1.).

The grantee must meet the applicable environmental requirements before the use or commitment of funds for each activity. After the Responsible Entity (1) completes environmental review(s) pursuant to 24 CFR part 58 and receives from HUD an approved Request for Release of Funds and certification (as applicable), or (2) adopts another Federal agency's environmental review, approval, or permit and receives from HUD (or the state) an approved Request for Release of Funds and certification (as applicable), the grantee may draw down funds from the line of credit for an activity. The disbursement of grant funds must begin no later than 180 calendar days after HUD executes a grant agreement with the grantee. Failure to draw funds within this timeframe may result in HUD's review of the grantee's certification of its financial controls, procurement processes, and capacity, and may result in the imposition of any corrective actions deemed appropriate by HUD pursuant to 24 CFR 570.495, 24 CFR 570.910, or 24 CFR 1003.701.

III.C.6. *Amending the action plan.* The grantee must amend its action plan to update its needs assessment, modify or create new activities, or reprogram funds, as necessary, in the DRGR system. Each amendment must be published on the grantee's official website and describe the changes within the context of the entire action plan. A grantee's current version of its entire action plan must be accessible for viewing as a single document at any given point in time, rather than require the public or HUD to view and cross-reference changes among multiple amendments. HUD's DRGR system will include the capabilities necessary for a grantee to sufficiently identify the changes for each amendment. When a grantee has finished amending the content in the Public Action Plan, the grantee will click "Submit Plan" in the DRGR system. The DRGR system will prompt the grantee to select the "Public Action Plan" and identify the amendment type (substantial or nonsubstantial). The grantee will complete this cover page to describe each amendment. At a minimum, the grantee must: (1) Identify exactly what content is being added, deleted, or changed; (2) clearly illustrate where funds are coming from and where they are moving to; and (3) include a revised budget allocation table that reflects the entirety of all funds, as amended.

III.C.6.a. *Substantial amendment.* In its action plan, each grantee must specify criteria for determining what changes in the grantee's plan constitute a substantial amendment to the plan. At a minimum, the following modifications will constitute a substantial amendment: A change in program benefit or eligibility criteria; the addition or deletion of an activity; a proposed reduction in the overall benefit requirement, as outlined in III.F.2.; or the allocation or reallocation of a monetary threshold specified by the grantee in their action plan. For all substantial amendments, the grantee must follow the same procedures required for the preparation and submission of an action plan for disaster recovery, with the exception of the public hearing requirements described

in section III.D.1.b. and the consultation requirements described in section III.D.1.a., which are not required for substantial amendments. A substantial action plan amendment shall require a 30-day public comment period.

III.C.6.b. *Nonsubstantial amendment.* The grantee must notify HUD, but is not required to seek public comment, when it makes any plan amendment that is not substantial. Although nonsubstantial amendments do not require HUD's approval to become effective, the DRGR system must approve the amendment to change the status of the Public Action Plan to "reviewed and approved." The DRGR system will automatically approve the amendment by the fifth day, if not completed by HUD sooner.

III.C.7. *Projection of expenditures and outcomes.* Each grantee must submit projected expenditures and outcomes with the action plan. The projections must be based on each quarter's expected performance—beginning with the first quarter funds are available to the grantee and continuing each quarter until all funds are expended. The grantee will use DRGR's upload feature to include projections and accomplishments for each program created.

### III.D. Citizen Participation Requirements

III.D.1. *Citizen participation waiver and alternative requirement.* To permit a more streamlined process and ensure disaster recovery grants are awarded in a timely manner, provisions of 42 U.S.C. 5304(a)(2) and (3), 42 U.S.C. 12707, 24 CFR 570.486, 24 CFR 1003.604, 24 CFR 91.105(b) through (d), and 24 CFR 91.115(b) through (d), with respect to citizen participation requirements, are waived and replaced by the alternative requirements in this section. The streamlined requirements require the grantee to include public hearings on the proposed action plan and provide a reasonable opportunity (at least 30 days) for citizen comment.

The grantee must follow a detailed citizen participation plan that satisfies the requirements of 24 CFR 91.115 or 91.105 (except as provided for in notices providing waivers and alternative requirements). Each local government receiving assistance from a state grantee must follow a detailed citizen participation plan that satisfies the requirements of 24 CFR 570.486 (except as provided for in notices providing waivers and alternative requirements).

In addition to the requirements above, the streamlined citizen participation alternative requirements for CDBG-DR grants are as follows:

III.D.1.a. *Requirement for consultation during plan preparation.* All grantees must consult with states, Indian tribes, local governments, Federal partners, nongovernmental organizations, the private sector, and other stakeholders and affected parties in the surrounding geographic area, including organizations that advocate on behalf of members of protected classes, vulnerable populations, and underserved communities impacted by the disaster, to ensure consistency of the action plan with applicable regional redevelopment plans. A grantee must consult with other relevant government agencies, including state and

local emergency management agencies that have primary responsibility for the administration of FEMA funds, if applicable.

III.D.1.b. *Publication of the action plan and opportunity for public comment.* Following the creation of the action plan or substantial amendment in DRGR and before the grantee submits the action plan or substantial amendment to HUD, the grantee must publish the proposed plan or amendment for public comment. The manner of publication must include prominent posting on the grantee's official disaster recovery website and must afford citizens, affected local governments, and other interested parties a reasonable opportunity to review the plan or substantial amendment. Grantees shall consider if there are potential barriers that may limit or prohibit vulnerable populations or underserved communities and individuals affected by the disaster from providing public comment on the grantee's action plan or substantial amendment. If the grantee identifies barriers that may limit or prohibit equitable participation, the grantee must take reasonable measures to increase coordination, communication, affirmative marketing, targeted outreach, and engagement with underserved communities and individuals, including persons with disabilities and persons with LEP.

At a minimum, the topic of disaster recovery on the grantee's website must be navigable by all interested parties from the grantee homepage and must link to the disaster recovery website required by section III.D.1.e. The grantee's records must demonstrate that it has notified affected citizens through electronic mailings, press releases, statements by public officials, media advertisements, public service announcements, and/or contacts with neighborhood organizations.

Additionally, the CDBG-DR grantee must convene at least one public hearing on the proposed action plan after it has published on its website to solicit public comment and before submittal of the action plan to HUD. If the grantee holds more than one public hearing, it must hold each hearing in a different location within the MID area in locations that the grantee determines will promote geographic balance and maximum accessibility. The minimum number of public hearings a grantee must convene on the action plan to obtain interested parties' views and to respond to comments and questions shall be determined by the amount of the grantee's CDBG-DR allocation: (1) CDBG-DR grantees with allocations under \$500 million are required to hold at least one public hearing in a HUD-identified MID area; and (2) CDBG-DR grantees with allocations over \$500 million or more shall convene at least two public hearings in HUD-identified MID areas.

Grantees may convene public hearings virtually (alone, or in concert with an in-person hearing). All in-person hearings must be held in facilities that are physically accessible to persons with disabilities. HUD's implementing regulations for Section 504 of the Rehabilitation Act (24 CFR part 8, subpart C) provide that where physical accessibility is not achievable, grantees must give priority to alternative methods of product or

information delivery that offer programs and activities to qualified individuals with disabilities in the most integrated setting appropriate. When conducting a virtual hearing, the grantee must allow questions in real time, with answers coming directly from the grantee representatives to all "attendees."

For both virtual and in person hearings, grantees must update their citizen participation plans to provide that hearings be held at times and locations convenient to potential and actual beneficiaries, with accommodation for persons with disabilities and appropriate auxiliary aids and services to ensure effective communication, and specify how they will meet these requirements. See 24 CFR 8.6 for HUD's regulations about effective communication. Grantees must also provide meaningful access for individuals with LEP at both in-person and virtual hearings. In their citizen participation plan, state and local government grantees shall identify how the needs of non-English speaking residents will be met in the case of virtual and in-person public hearings where a significant number of non-English speaking residents can be reasonably expected to participate. In addition, for both virtual or in-person hearings, the grantee shall provide reasonable notification and access for citizens in accordance with the grantee's certifications at III.F.7.g., timely responses to all citizen questions and issues, and public access to all questions and responses.

III.D.1.c. *Consideration of public comments.* The grantee must provide a reasonable time frame (no less than 30 days) and method(s) (including electronic submission) for receiving comments on the action plan or substantial amendment. The grantee must consider all oral and written comments on the action plan or any substantial amendment. Any updates or changes made to the action plan in response to public comments should be clearly identified in the action plan. A summary of comments on the plan or amendment, and the grantee's response to each, must be included (e.g., uploaded) in DRGR with the action plan or substantial amendment. Grantee responses shall address the substance of the comment rather than merely acknowledge that the comment was received.

III.D.1.d. *Availability and accessibility of documents.* The grantee must make the action plan, any substantial amendments, vital documents, and all performance reports available to the public on its website. See the following guidance for more information on vital documents: [https://www.lep.gov/guidance/HUD\\_guidance\\_Jan07.pdf](https://www.lep.gov/guidance/HUD_guidance_Jan07.pdf). In addition, the grantee must make these documents available in a form accessible to persons with disabilities and those with LEP. Grantees must take reasonable steps to ensure meaningful access to their programs and activities by LEP persons, including members of protected classes, vulnerable populations, and individuals from underserved communities. In their citizen participation plan, state and local government grantees shall describe their procedures for assessing their language needs and identify any need for translation of notices and other vital documents. At a minimum, the citizen participation plan shall require that the state

or local government grantee take reasonable steps to provide language assistance to ensure meaningful access to participation by non-English-speaking residents of the grantee's jurisdiction.

III.D.1.e. *Public website.* The grantee must maintain a public website that permits individuals and entities awaiting assistance and the general public to see how all grant funds are used and administered. The website must include copies of all relevant procurement documents and, except as noted in the next paragraph, all grantee administrative contracts, details of ongoing procurement processes, and action plans and amendments. The public website must be accessible to persons with disabilities and individuals with LEP.

To meet this requirement, each grantee must make the following items available on its website: The action plan created using DRGR (including all amendments); each performance report (as created using the DRGR system); citizen participation plan; procurement policies and procedures; all contracts, as defined in 2 CFR 200.22, that will be paid with CDBG-DR funds (including, but not limited to, subrecipients' contracts); and a summary including the description and status of services or goods currently being procured by the grantee or the subrecipient (e.g., phase of the procurement, requirements for proposals, etc.). Contracts and procurement actions that do not exceed the micro-purchase threshold, as defined in 2 CFR 200.1, are not required to be posted to a grantee's website.

III.D.1.f. *Application status.* The grantee must provide multiple methods of communication, such as websites, toll-free numbers, TTY and relay services, email address, fax number, or other means to provide applicants for recovery assistance with timely information to determine the status of their application.

III.D.1.g. *Citizen complaints.* The grantee will provide a timely written response to every citizen complaint. The grantee response must be provided within fifteen working days of the receipt of the complaint, or the grantee must document why additional time for the response was required.

Complaints regarding fraud, waste, or abuse of government funds should be forwarded to the HUD OIG Fraud Hotline (phone: 1-800-347-3735 or email: [hotline@hudoig.gov](mailto:hotline@hudoig.gov)).

III.D.1.h. *General requirements.* For plan publication, the comprehensive disaster recovery website and vital documents must ensure effective communication for individuals with disabilities, as required by 24 CFR 8.6 and the Americans with Disabilities Act, as applicable. In addition to ensuring the accessibility of the comprehensive disaster recovery website and vital documents, this obligation includes the requirement to provide auxiliary aids and services where necessary to ensure effective communication with individuals with disabilities, which may take the form of the furnishing of the above referenced materials in alternative formats (24 CFR 8.6(a)(1)). When required by III.D.1.d., grantees must take reasonable steps to ensure meaningful access for individuals with LEP.

### III.E. Program Income

III.E.1. *Program income waiver and alternative requirement.* For state and unit of general local government grantees, HUD is waiving all applicable program income rules at 42 U.S.C. 5304(j), 24 CFR 570.489(e), 24 CFR 570.500, and 24 CFR 570.504 and providing the alternative requirement described below. Program income earned by Indian tribes that receive an allocation from HUD will be governed by the regulations at 24 CFR 1003.503 until grant closeout and not by the waivers and alternative requirements in this Consolidated Notice. Program income earned by Indian tribes that are subrecipients of state grantees or local government grantees will be subject to the program income requirements for subrecipients of those grantees.

III.E.1.a. *Definition of program income.* “Program income” is defined as gross income generated from the use of CDBG–DR funds, except as provided in III.E.1.b., and received by a state, local government, Indian tribe receiving funds from a grantee, or their subrecipients. When income is generated by an activity that is only partially assisted with CDBG–DR funds, the income shall be prorated to reflect the percentage of CDBG–DR funds used (e.g., a single loan supported by CDBG–DR funds and other funds, or a single parcel of land purchased with CDBG–DR funds and other funds). If CDBG funds are used with CDBG–DR funds on an activity, any income earned on the CDBG portion would not be subject to the waiver and alternative requirement in the Consolidated Notice.

Program income includes, but is not limited to, the following:

(i) Proceeds from the disposition by sale or long-term lease of real property purchased or improved with CDBG–DR funds.

(ii) Proceeds from the disposition of equipment purchased with CDBG–DR funds.

(iii) Gross income from the use or rental of real or personal property acquired by a state, local government, or subrecipient thereof with CDBG–DR funds, less costs incidental to generation of the income.

(iv) Gross income from the use or rental of real property owned by a state, local government, or subrecipient thereof, that was constructed or improved with CDBG–DR funds, less costs incidental to generation of the income.

(v) Payments of principal and interest on loans made using CDBG–DR funds.

(vi) Proceeds from the sale of loans made with CDBG–DR funds.

(vii) Proceeds from the sale of obligations secured by loans made with CDBG–DR funds.

(viii) Interest earned on program income pending disposition of the income, including interest earned on funds held in a revolving fund account.

(ix) Funds collected through special assessments made against nonresidential properties and properties owned and occupied by non-LMI households, where the special assessments are used to recover all or part of the CDBG–DR portion of a public improvement.

(x) Gross income paid to a state, local government, or subrecipient thereof, from the ownership interest in a for-profit entity in

which the income is in return for the provision of CDBG–DR assistance.

III.E.1.b. *Program income—does not include:*

(i) The total amount of funds that is less than \$35,000 received in a single year and retained by a state, local government, or a subrecipient thereof.

(ii) Amounts generated by activities eligible under section 105(a)(15) of the HCDA and carried out by an entity under the authority of section 105(a)(15) of the HCDA.

III.E.1.c. *Retention of program income.* State grantees may permit a local government that receives or will receive program income to retain the program income but are not required to do so.

III.E.1.d. *Program income—use, close out, and transfer.*

(i) Program income received (and retained, if applicable) before or after closeout of the grant that generated the program income, and used to continue disaster recovery activities, is treated as additional CDBG–DR funds subject to the requirements of the Consolidated Notice and must be used in accordance with the grantee’s action plan for disaster recovery. To the maximum extent feasible, program income shall be used or distributed before additional withdrawals from the U.S. Treasury are made, except as provided in III.E.1.e. below.

(ii) In addition to the alternative requirements dealing with program income required above, the following rules apply:

(1) A state or local government grantee may transfer program income to its annual CDBG program before closeout of the grant that generated the program income. In addition, state grantees may transfer program income before closeout to any annual CDBG-funded activities carried out by a local government within the state.

(2) Program income received by a grantee, or received and retained by a subrecipient, after closeout of the grant that generated the program income, may also be transferred to a grantee’s annual CDBG award.

(3) In all cases, any program income received that is not used to continue the disaster recovery activity will not be subject to the waivers and alternative requirements of the Consolidated Notice. Rather, those funds will be subject to the state or local government grantee’s regular CDBG program rules. Any other transfer of program income not specifically addressed in the Consolidated Notice may be carried out if the grantee first seeks and then receives HUD’s approval.

III.E.1.e. *Revolving funds.* State and local government grantees may establish revolving funds to carry out specific, identified activities. State grantees may also establish a revolving fund to distribute funds to local governments or tribes to carry out specific, identified activities. A revolving fund, for this purpose, is a separate fund (with a set of accounts that are independent of other program accounts) established to carry out specific activities. These activities must generate payments used to support similar activities going forward. These payments to the revolving fund are program income and must be substantially disbursed from the revolving fund before additional grant funds

are drawn from the U.S. Treasury for payments that could be funded from the revolving fund. Such program income is not required to be disbursed for nonrevolving fund activities. A revolving fund established by a CDBG–DR grantee shall not be directly funded or capitalized with CDBG–DR grant funds, pursuant to 24 CFR 570.489(f)(3).

### III.F. Other General Waivers and Alternative Requirements

III.F.1. *Consolidated Plan waiver.* HUD is temporarily waiving the requirement for consistency with the consolidated plan (requirements at 42 U.S.C. 12706, 24 CFR 91.225(a)(5), and 24 CFR 91.325(a)(5)), because the effects of a major disaster alter a grantee’s priorities for meeting housing, employment, and infrastructure needs. In conjunction, 42 U.S.C. 5304(e) is also waived, to the extent that it would require HUD to annually review grantee performance under the consistency criteria. These waivers apply only for 24 months after the applicability date of the grantee’s applicable Allocation Announcement Notice. If the grantee is not scheduled to submit a new three-to five-year consolidated plan within the next two years, the grantee must update its existing three-to five-year consolidated plan to reflect disaster-related needs no later than 24 months after the applicability date of the grantee’s applicable Allocation Announcement Notice.

III.F.2. *Overall benefit requirement.* The primary objective of the HCDA is the “development of viable urban communities, by providing decent housing and a suitable living environment and expanding economic opportunities, principally for persons of low and moderate income” (42 U.S.C. 5301(c)). Consistent with the HCDA, this notice requires grantees to comply with the overall benefit requirements in the HCDA and 24 CFR 570.484, 24 CFR 570.200(a)(3), and 24 CFR 1003.208, which require that 70 percent of funds be used for activities that benefit LMI persons. For purposes of a CDBG–DR grant, HUD is establishing an alternative requirement that the overall benefit test shall apply only to the grant of CDBG–DR funds described in the Allocation Announcement Notice and related program income.

A grantee may seek to reduce the overall benefit requirement below 70 percent of the total grant, but must submit a substantial amendment as provided in section III.C.6.a. in the Consolidated Notice, and provide a justification that, at a minimum: (a) Identifies the planned activities that meet the needs of its LMI population; (b) describes proposed activities and programs that will be affected by the alternative requirement, including their proposed location(s) and role(s) in the grantee’s long-term disaster recovery plan; (c) describes how the activities/programs identified in (b) prevent the grantee from meeting the 70 percent requirement; (d) demonstrates that LMI persons’ disaster-related needs have been sufficiently met and that the needs of non-LMI persons or areas are disproportionately greater, and that the jurisdiction lacks other resources to serve non-LMI persons; and (e) demonstrates a compelling need for HUD to lower the percentage of the grant that must benefit low- and moderate-income persons.



III.F.3. *Use of the urgent need national objective.* Because HUD provides CDBG–DR funds only to grantees with documented disaster-related impacts and each grantee is limited to spending funds only for the benefit of areas that received a Presidential disaster declaration, the Secretary finds good cause to waive the urgent need national objective criteria in section 104(b)(3) of the HCDA and to establish the following alternative requirement for any CDBG–DR grantee using the urgent need national objective for a period of 36 months after the applicability date of the grantee’s Allocation Announcement Notice.

Pursuant to this alternative requirement, grantees that use the urgent need national objective must: (1) Describe in the impact and unmet needs assessment why specific needs have a particular urgency, including how the existing conditions pose a serious and immediate threat to the health or welfare of the community; (2) identify each program or activity in the action plan that will use the urgent need national objective—either through its initial action plan submission or through a substantial amendment submitted by the grantee within 36 months of the applicability date of the grantee’s Allocation Announcement Notice; and (3) document how each program and/or activity funded under the urgent need national objective in the action plan responds to the urgency, type, scale, and location of the disaster-related impact as described in the grantee’s impact and unmet needs assessment.

The grantee’s action plan must address all three criteria described above to use the alternative urgent need national objective for the program and/or activity. This alternative urgent need national objective is in effect for a period of 36 months following the applicability date of the grantee’s Allocation Announcement Notice. After 36 months, the grantee will be required to follow the criteria established in section 104(b)(3) of the HCDA and its implementing regulations in 24 CFR part 570 when using the urgent need national objective for any new programs and/or activities added to an action plan.

III.F.4. *Reimbursement of disaster recovery expenses by a grantee or subrecipient.* The provisions of 24 CFR 570.489(b) are applied to permit a state grantee to charge to the grant otherwise allowable costs incurred by the grantee, its recipients or subrecipients (including Indian tribes and PHAs) on or after the incident date of the covered disaster. A local government grantee is subject to the provisions of 24 CFR 570.200(h) but may reimburse itself or its subrecipients for otherwise allowable costs incurred on or after the incident date of the covered disaster. Section 570.200(h)(1)(i) is waived to the extent that it requires pre-agreement activities to be included in the local government’s consolidated plan. As an alternative requirement, grantees must include any pre-agreement activities in their action plans, including any costs of eligible activities that were funded with short-term loans (e.g., bridge loans) and that the grantee intends to reimburse or otherwise charge to the grant, consistent with applicable program requirements.

III.F.5. *Reimbursement of pre-application costs of homeowners, renters, businesses, and*

*other qualifying entities.* Grantees are permitted to charge to grants the pre-award and pre-application costs of homeowners, renters, businesses, and other qualifying entities for eligible costs these applicants have incurred in response to an eligible disaster covered under a grantees’ applicable Allocation Announcement Notice. For purposes of the Consolidated Notice, pre-application costs are costs incurred by an applicant to CDBG–DR funded programs before the time of application to a grantee or subrecipient, which may be before (pre-award) or after the grantee signs its CDBG–DR grant agreement. In addition to the terms described in the remainder of the Consolidated Notice, grantees may only charge costs to the grant that meet the following requirements:

- Grantees may only charge the costs for rehabilitation, demolition, and reconstruction of single family, multifamily, and nonresidential buildings, including commercial properties, owned by private individuals and entities, incurred before the owner applies to a CDBG–DR grantee, recipient, or subrecipient for CDBG–DR assistance;
- For rehabilitation and reconstruction costs, grantees may only charge costs for activities completed within the same footprint of the damaged structure, sidewalk, driveway, parking lot, or other developed area;
- As required by 2 CFR 200.403(g), costs must be adequately documented; and
- Grantees must complete a duplication of benefits check before providing assistance pursuant to section IV.A. in the Consolidated Notice.

Grantees are required to ensure that all costs charged to a CDBG–DR grant are necessary expenses related to authorized recovery purposes. Grantees may charge to CDBG–DR grants the eligible pre-application costs of individuals and private entities related to single family, multifamily, and nonresidential buildings, only if: (1) The person or private entity incurred the expenses within one year after the applicability date of the grantee’s Allocation Announcement Notice (or within one year after the date of the disaster, whichever is later); and (2) the person or entity pays for the cost before the date on which the person or entity applies for CDBG–DR assistance. Exempt activities as defined at 24 CFR 58.34, but not including 24 CFR 58.34(a)(12), and categorical exclusions as defined at 24 CFR 58.35(b) are not subject to the time limit on pre-application costs outlined above. Actions that convert or potentially convert to exempt under 24 CFR 58.34(a)(12) remain subject to the reimbursement requirements provided herein. If a grantee cannot meet all requirements at 24 CFR part 58, the pre-application costs cannot be reimbursed with CDBG–DR or other HUD funds.

Grantees must comply with the necessary and reasonable cost principles for state, local, and Indian tribal governments (described at 2 CFR 200.403). Grantees must incorporate into their policies and procedures the basis for determining that the assistance provided under the terms of this provision is necessary and reasonable.

A grantee may not charge such pre-award or pre-application costs to grants if the grantee cannot meet all requirements at 24 CFR part 58. Under CDBG–DR authorizing legislation and HUD’s environmental regulations in 24 CFR part 58, the CDBG–DR “recipient” (as defined in 24 CFR part 58.2(a)(5), which differs from the definition in 2 CFR part 200) is the responsible entity that assumes the responsibility for completing environmental reviews under Federal laws and authorities. The responsible entity assumes all legal liability for the application, compliance, and enforcement of these requirements. Pre-award costs are also allowable when CDBG–DR assistance is provided for the rehabilitation, demolition, or reconstruction of government buildings, public facilities, and infrastructure. However, in such instances, the environmental review must occur before the underlying activity (e.g., rehabilitation of a government building) begins.

Grantees are also required to consult with the State Historic Preservation Officer, Fish and Wildlife Service, and National Marine Fisheries Service, to obtain formal agreements for compliance with section 106 of the National Historic Preservation Act (54 U.S.C. 306108) and section 7 of the Endangered Species Act of 1973 (16 U.S.C. 1536) when designing a reimbursement program.

All grantees must follow all cross-cutting requirements, as applicable, for all CDBG–DR funded activities including but not limited to the environmental requirements above, the Davis Bacon Act, Civil Rights Requirements, HUD’s Lead Safe Housing Rule, and the URA.

III.F.6. *Alternative requirement for the elevation of structures when using CDBG–DR funds as the non-Federal match in a FEMA-funded project.* Currently, CDBG–DR grantees using FEMA and CDBG–DR funds on the same activity have encountered challenges in certain circumstances in reconciling CDBG–DR elevation requirements and those established by FEMA. FEMA regulations at 44 CFR 9.11(d)(3)(i) and (ii) prohibit new construction or substantial improvements to a structure unless the lowest floor of the structure is at or above the level of the base flood and, for Critical Actions, at or above the level of the 500-year flood. However, 44 CFR 9.11(d)(3)(iii) allows for an alternative to elevation to the 100- or 500-year flood level, subject to FEMA approval, which would provide for improvements that would ensure the substantial impermeability of the structure below flood level. While FEMA may change its standards for elevation in the future, as long as the CDBG–DR grantee is following a FEMA-approved flood standard this waiver and alternative requirement will continue to apply.

FEMA funded projects generally commence well in advance of the availability of CDBG–DR funds and when CDBG–DR funds are used as match for a FEMA project that is underway, the alignment of HUD’s elevation standards with any alternative standard allowed by FEMA may not be feasible and may not be cost reasonable. For these reasons, the Secretary finds good cause to establish an alternative requirement for the use of an alternative, FEMA-approved flood

standard instead of the elevation requirements established in section II.B.2.c. and II.C.2. of the Consolidated Notice.

The alternative requirements apply when: (a) CDBG–DR funds are used as the non-Federal match for FEMA assistance; (b) the FEMA-assisted activity, for which CDBG–DR funds will be used as match, commenced before HUD’s obligation of CDBG–DR funds to the grantee; and (c) the grantee has determined and demonstrated with records in the activity file that implementation costs of the required CDBG–DR elevation or flood proofing requirements are not reasonable costs, as that term is defined in the applicable cost principles at 2 CFR 200.404.

III.F.7. *Certifications waiver and alternative requirement.* Sections 104(b)(4), (c), and (m) of the HCDA (42 U.S.C. 5304(b)(4), (c) & (m)), sections 106(d)(2)(C) & (D) of the HCDA (42 U.S.C. 5306(d)(2)(C) & (D)), and section 106 of the Cranston-Gonzalez National Affordable Housing Act (42 U.S.C. 12706), and regulations at 24 CFR 91.225 and 91.325 are waived and replaced with the following alternative. Each grantee receiving an allocation under an Allocation Announcement Notice must make the following certifications with its action plan:

a. The grantee certifies that it has in effect and is following a residential anti-displacement and relocation assistance plan (RARAP) in connection with any activity assisted with CDBG–DR grant funds that fulfills the requirements of Section 104(d), 24 CFR part 42, and 24 CFR part 570, as amended by waivers and alternative requirements.

b. The grantee certifies its compliance with restrictions on lobbying required by 24 CFR part 87, together with disclosure forms, if required by part 87.

c. The grantee certifies that the action plan for disaster recovery is authorized under state and local law (as applicable) and that the grantee, and any entity or entities designated by the grantee, and any contractor, subrecipient, or designated public agency carrying out an activity with CDBG–DR funds, possess(es) the legal authority to carry out the program for which it is seeking funding, in accordance with applicable HUD regulations as modified by waivers and alternative requirements.

d. The grantee certifies that activities to be undertaken with CDBG–DR funds are consistent with its action plan.

e. The grantee certifies that it will comply with the acquisition and relocation requirements of the URA, as amended, and implementing regulations at 49 CFR part 24, as such requirements may be modified by waivers or alternative requirements.

f. The grantee certifies that it will comply with section 3 of the Housing and Urban Development Act of 1968 (12 U.S.C. 1701u) and implementing regulations at 24 CFR part 75.

g. The grantee certifies that it is following a detailed citizen participation plan that satisfies the requirements of 24 CFR 91.115 or 91.105 (except as provided for in waivers and alternative requirements). Also, each local government receiving assistance from a state grantee must follow a detailed citizen participation plan that satisfies the

requirements of 24 CFR 570.486 (except as provided for in waivers and alternative requirements).

h. State grantee certifies that it has consulted with all disaster-affected local governments (including any CDBG-entitlement grantees), Indian tribes, and any local public housing authorities in determining the use of funds, including the method of distribution of funding, or activities carried out directly by the state.

i. The grantee certifies that it is complying with each of the following criteria:

(1) Funds will be used solely for necessary expenses related to disaster relief, long-term recovery, restoration of infrastructure and housing, economic revitalization, and mitigation in the most impacted and distressed areas for which the President declared a major disaster pursuant to the Robert T. Stafford Disaster Relief and Emergency Assistance Act of 1974 (42 U.S.C. 5121 *et seq.*).

(2) With respect to activities expected to be assisted with CDBG–DR funds, the action plan has been developed so as to give the maximum feasible priority to activities that will benefit low- and moderate-income families.

(3) The aggregate use of CDBG–DR funds shall principally benefit low- and moderate-income families in a manner that ensures that at least 70 percent (or another percentage permitted by HUD in a waiver) of the grant amount is expended for activities that benefit such persons.

(4) The grantee will not attempt to recover any capital costs of public improvements assisted with CDBG–DR grant funds, by assessing any amount against properties owned and occupied by persons of low- and moderate-income, including any fee charged or assessment made as a condition of obtaining access to such public improvements, unless: (a) Disaster recovery grant funds are used to pay the proportion of such fee or assessment that relates to the capital costs of such public improvements that are financed from revenue sources other than under this title; or (b) for purposes of assessing any amount against properties owned and occupied by persons of moderate income, the grantee certifies to the Secretary that it lacks sufficient CDBG funds (in any form) to comply with the requirements of clause (a).

j. State and local government grantees certify that the grant will be conducted and administered in conformity with title VI of the Civil Rights Act of 1964 (42 U.S.C. 2000d), the Fair Housing Act (42 U.S.C. 3601–3619), and implementing regulations, and that it will affirmatively further fair housing. An Indian tribe grantee certifies that the grant will be conducted and administered in conformity with the Indian Civil Rights Act.

k. The grantee certifies that it has adopted and is enforcing the following policies, and, in addition, state grantees must certify that they will require local governments that receive their grant funds to certify that they have adopted and are enforcing:

(1) A policy prohibiting the use of excessive force by law enforcement agencies within its jurisdiction against any

individuals engaged in nonviolent civil rights demonstrations; and

(2) A policy of enforcing applicable state and local laws against physically barring entrance to or exit from a facility or location that is the subject of such nonviolent civil rights demonstrations within its jurisdiction.

l. The grantee certifies that it (and any subrecipient or administering entity) currently has or will develop and maintain the capacity to carry out disaster recovery activities in a timely manner and that the grantee has reviewed the requirements applicable to the use of grant funds.

m. The grantee certifies to the accuracy of its Financial Management and Grant Compliance Certification Requirements, or other recent certification submission, if approved by HUD, and related supporting documentation as provided in section III.A.1. of the Consolidated Notice and the grantee’s implementation plan and related submissions to HUD as provided in section III.A.2. of the Consolidated Notice.

n. The grantee certifies that it will not use CDBG–DR funds for any activity in an area identified as flood prone for land use or hazard mitigation planning purposes by the state, local, or tribal government or delineated as a Special Flood Hazard Area (or 100-year floodplain) in FEMA’s most current flood advisory maps, unless it also ensures that the action is designed or modified to minimize harm to or within the floodplain, in accordance with Executive Order 11988 and 24 CFR part 55. The relevant data source for this provision is the state, local, and tribal government land use regulations and hazard mitigation plans and the latest-issued FEMA data or guidance, which includes advisory data (such as Advisory Base Flood Elevations) or preliminary and final Flood Insurance Rate Maps.

o. The grantee certifies that its activities concerning lead-based paint will comply with the requirements of 24 CFR part 35, subparts A, B, J, K, and R.

p. The grantee certifies that it will comply with environmental requirements at 24 CFR part 58.

q. The grantee certifies that it will comply with the provisions of title I of the HCDA and with other applicable laws.

Warning: Any person who knowingly makes a false claim or statement to HUD may be subject to civil or criminal penalties under 18 U.S.C. 287, 1001, and 31 U.S.C. 3729.

### III.G. Ineligible Activities in CDBG–DR

Any activity that is not authorized under Section 105(a) of the HCDA is ineligible to be assisted with CDBG–DR funds, unless explicitly allowed by waiver and alternative requirement in the Consolidated Notice. Additionally, the uses described below are explicitly prohibited.

III.G.1. *Prohibition on compensation.* Grantees shall not use CDBG–DR funds to provide compensation to beneficiaries for losses stemming from disaster related impacts. Grantees may, however, reimburse disaster-impacted beneficiaries based on the pre-application costs incurred by the beneficiary to complete an eligible activity. Reimbursement of beneficiaries for eligible activity costs are subject to the requirements

established in section III.F.5. of the Consolidated Notice.

III.G.2. *Prohibition on forced mortgage payoff.* A forced mortgage payoff occurs when homeowners with an outstanding mortgage balance are required, under the terms of their loan agreement, to repay the balance of the mortgage loan before using assistance to rehabilitate or reconstruct their homes. CDBG–DR funds, however, shall not be used for a forced mortgage payoff. The ineligibility of a forced mortgage payoff with CDBG–DR funds does not affect HUD’s longstanding guidance that when other non-CDBG disaster assistance is taken by lenders for a forced mortgage payoff, those funds are not considered to be available to the homeowner and do not constitute a duplication of benefits for the purpose of housing rehabilitation or reconstruction.

III.G.3. *Prohibiting assistance to private utilities.* HUD is adopting the following alternative requirement to section 105(a) and prohibiting the use of CDBG–DR funds to assist a privately-owned utility for any purpose.

#### IV. Other Program Requirements

##### IV.A. Duplication of Benefits

The grantee must comply with section 312 of the Stafford Act, as amended, which prohibits any person, business concern, or other entity from receiving financial assistance with respect to any part of a loss resulting from a major disaster for which such person, business concern, or other entity has received financial assistance under any other program or from insurance or any other source. To comply with section 312, a person or entity may receive financial assistance only to the extent that the person or entity has a disaster recovery need that has not been fully met. Grantees must also establish policies and procedures to provide for the repayment of a CDBG–DR award when assistance is subsequently provided for that same purpose from any other source. Grantees may be subject to additional DOB requirements described in a separate notice. The applicable Allocation Announcement Notice will describe any additional requirements, as applicable.

Subsidized loans are financial assistance and therefore can duplicate financial assistance provided from another source unless an exception in IV.A.1. applies.

IV.A.1. *Exceptions when subsidized loans are not a duplication.* When an exception described in paragraphs IV.A.1.a. or IV.A.1.b. applies, documentation required by those paragraphs must be maintained by the grantee. Without this documentation, any approved but undisbursed portion of a subsidized loan must be included in the grantee’s calculation of the total assistance amount unless another exception applies. For cancelled SBA loans, the grantee must notify the SBA that the applicant has agreed to not take any actions to reinstate the cancelled loan or draw any additional undisbursed loan amounts.

IV.A.1.a. *Short-term subsidized loans for costs later reimbursed with CDBG–DR.* CDBG–DR funds may be used to reimburse pre-award costs of the grantee or subrecipient for eligible activities on or after the date of

the disaster. If the grantee or subrecipient obtained a subsidized short-term loan to pay for eligible costs before CDBG–DR funds became available (for example, a low-interest loan from a local tax increment financing fund), the reimbursement of the costs paid by the loan does not create a duplication.

IV.A.1.b. *Declined or cancelled subsidized loans.* The amount of a subsidized loan that is declined or cancelled is not a DOB. To exclude declined or cancelled loan amounts from the DOB calculation, the grantee must document that all or a portion of the subsidized loan is cancelled or declined.

(i) *Declined SBA Loans:* Declined loan amounts are loan amounts that were approved or offered by a lender in response to a loan application, but were turned down by the applicant, meaning the applicant never signed loan documents to receive the loan proceeds.

CDBG–DR grantees shall not treat declined subsidized loans, including declined SBA loans, as a DOB (but are not prohibited from considering declined subsidized loans for other reasons, such as underwriting). A grantee is only required to document declined loans if information available to the grantee (e.g., the data the grantee receives from FEMA, SBA, or other sources) indicates that the applicant received an offer for subsidized loan assistance, and the grantee is unable to determine from that available information that the applicant declined the loan. If the grantee is aware that the applicant received an offer of loan assistance and cannot ascertain from available data that the applicant declined the loan, the grantee must obtain a written certification from the applicant that the applicant did not accept the subsidized loan by signing loan documents and did not receive the loan.

(ii) *Cancelled Loans:* Cancelled loans are loans (or portions of loans) that were initially accepted, but for a variety of reasons, all or a portion of the loan amount was not disbursed and is no longer available to the applicant.

The cancelled loan amount is the amount that is no longer available. The loan cancellation may be due to default of the borrower, agreement by both parties to cancel the undisbursed portion of the loan, or expiration of the term for which the loan was available for disbursement. The following documentation is sufficient to demonstrate that any undisbursed portion of an accepted subsidized loan is cancelled and no longer available: (a) A written communication from the lender confirming that the loan has been cancelled and undisbursed amounts are no longer available to the applicant; or (b) a legally binding agreement between the CDBG–DR grantee (or local government, Indian tribe, or subrecipient administering the CDBG–DR assistance) and the applicant that indicates that the period of availability of the loan has passed and the applicant agrees not to take actions to reinstate the loan or draw any additional undisbursed loan amounts.

##### IV.B. Procurement

For a grantee to have proficient procurement processes, a grantee must: Indicate the procurement standards that

apply to its use of CDBG–DR funds; indicate the procurement standards for subrecipients or local governments as applicable; comply with the standards it certified to HUD that it follows (and update the certification submissions when substantial changes are made); post the required documentation to the official website as described below; and include periods of performance and date of completion in all CDBG–DR contracts.

State grantees must comply with the procurement requirements at 24 CFR 570.489(g) and the following alternative requirements: The grantee must evaluate the cost or price of the product or service being procured. State grantees shall establish requirements for procurement processes for local governments and subrecipients based on full and open competition consistent with the requirements of 24 CFR 570.489(g), and shall require a local government or subrecipient to evaluate the cost or price of the product or service being procured with CDBG–DR funds. Additionally, if the state agency designated as the administering agency chooses to provide funding to another state agency, the administering agency must specify in its procurement processes whether the agency implementing the CDBG–DR activity must follow the procurement processes that the administering agency is subject to, or whether the agency must follow the same processes to which other local governments and subrecipients are subject, or its own procurement processes.

A grantee shall administer CDBG–DR grant funds in accordance with all applicable laws and regulations. As an alternative requirement, grantees may not delegate, by contract, or otherwise, the responsibility for administering such grant funds.

HUD is establishing an additional alternative requirement for all contracts with contractors used to provide goods and services, as follows:

1. The grantee (or procuring entity) is required to clearly state the period of performance or date of completion in all contracts;
2. The grantee (or procuring entity) must incorporate performance requirements and liquidated damages into each procured contract. Contracts that describe work performed by general management consulting services need not adhere to the requirement on liquidated damages but must incorporate performance requirements; and
3. The grantee (or procuring entity) may contract for administrative support, in compliance with 2 CFR 200.459, but may not delegate or contract to any other party any inherently governmental responsibilities related to oversight of the grant, including policy development, fair housing and civil rights compliance, and financial management.

##### IV.C. Use of the “Upper Quartile” or “Exception Criteria”

The LMA benefit requirement is modified when fewer than one quarter of the populated-block groups in its jurisdictions contain 51 percent or more LMI persons. In such a community, activities must serve an area that contains a percentage of LMI residents that is within the upper quartile of

all census-block groups within its jurisdiction in terms of the degree of concentration of LMI residents. HUD determines the lowest proportion a grantee may use to qualify an area for this purpose and advises the grantee, accordingly. The “exception criteria” applies to CDBG–DR funded activities in jurisdictions covered by such criteria, including jurisdictions that receive disaster recovery funds from a state. Disaster recovery grantees are required to use the most recent data available in implementing the exception criteria (<https://www.hudexchange.info/programs/acs-low-mod-summary-data/acs-low-mod-summary-data-exception-grantees/>).

#### IV.D. Environmental Requirements

IV.D.1. *Clarifying note on the process for environmental release of funds when a state carries out activities directly.* For CDBG–DR grants, HUD allows state grantees to carry out activities directly and to distribute funds to subrecipients. Per 24 CFR 58.4(b)(1), when a state carries out activities directly (including through subrecipients that are not units of general local government), the state must submit the Certification and Request for Release of Funds to HUD for approval.

IV.D.2. *Adoption of another agency’s environmental review.* Appropriations acts allow recipients of funds that use such funds to supplement Federal assistance provided under section 402, 403, 404, 406, 407, 408(c)(4), or 502 of the Stafford Act to adopt, without review or public comment, any environmental review, approval, or permit performed by a Federal agency. Such adoption shall satisfy the responsibilities of the recipient with respect to such environmental review, approval, or permit.

This provision allows the recipient of supplemental assistance to adopt another Federal agency’s review where the HUD assistance supplements the Stafford Act, and the other Federal agency performed an environmental review for assistance under section 402, 403, 404, 406, 407, or 502 of the Stafford Act.

The other agency’s environmental review must cover all project activities funded by the HUD recipient for each project. The grantee is only required to supplement the other agency’s environmental review to comply with HUD regulations (e.g., publication or posting requirements for Notice of Finding of No Significant Impact (FONSI), Notice of Intent to Request Release of Funds (NOI–RROF), concurrent or combined notices, or HUD approval period for objections) if the activity is modified so the other agency’s environmental review no longer covers the activity. The recipient’s environmental review obligations are considered complete when adopting another agency’s environmental review. To be adequate:

1. The grantee must obtain a completed electronic or paper copy of the Federal agency’s review and retain a copy in its environmental records.

2. The grantee must notify HUD on the Request for Release of Funds (RROF) Form 7015.15 (or the state, if the state is acting as HUD under 24 CFR 58.18) that another agency review is being used. The grantee

must include the name of the other Federal agency, the name of the project, and the date of the project’s review as prepared by the other Federal agency.

When permitted by the applicable appropriations acts, and notwithstanding 42 U.S.C. 5304(g)(2), the Secretary or a state may, upon receipt of a Request for Release of Funds and Certification, immediately approve the release of funds for an activity or project assisted with CDBG–DR funds if the recipient has adopted an environmental review, approval, or permit under this section, or if the activity or project is categorically excluded from review under the National Environmental Policy Act of 1969 (42 U.S.C. 4321 *et seq.*) (NEPA).

IV.D.3. *Historic preservation reviews.* The responsible entity must comply with section 106 of the National Historic Preservation Act of 1966 (54 U.S.C. Section 306108). Early coordination under section 106 is important to the recovery process and required by 24 CFR 58.5(a).

IV.D.4. *Tiered environmental reviews.* Tiering, as described at 40 CFR 1508.1(ff) and 24 CFR 58.15, is a means of making the environmental review process more efficient by allowing parties to “eliminate repetitive discussions of the same issues, focus on the actual issues ripe for decision, and exclude from consideration issues already decided or not yet ripe at each level of environmental review” (40 CFR 1501.11(a)). Tiering is appropriate when a responsible entity is evaluating a single-family housing program with similar activities within a defined local geographic area and timeframe (e.g., rehabilitating single-family homes within a city district or county over the course of one to five years) but where the specific sites and activities are not yet known. Public notice and the Request for Release of Funds (HUD-Form 7015.15) are processed at a broad-level, eliminating the need for publication at the site-specific level. However, funds cannot be spent or committed on a specific site or activity until the site-specific review has been completed and approved.

#### IV.E. Flood Insurance Requirements

Grantees, recipients, and subrecipients must implement procedures and mechanisms to ensure that assisted property owners comply with all flood insurance requirements, including the purchase and notification requirements described below, before providing assistance.

IV.E.1. *Flood insurance purchase requirements.* When grantees use CDBG–DR funds to rehabilitate or reconstruct existing residential buildings in a Special Flood Hazard Area (or 100-year floodplain), the grantee must comply with applicable Federal, state, local, and tribal laws and regulations related to both flood insurance and floodplain management. The grantee must comply with section 102(a) of the Flood Disaster Protection Act of 1973 (42 U.S.C. 4012a) which mandates the purchase of flood insurance protection for any HUD-assisted property within a Special Flood Hazard Area. Therefore, a HUD-assisted homeowner for a property located in a Special Flood Hazard Area must obtain and maintain flood insurance in the amount and duration

prescribed by FEMA’s National Flood Insurance Program.

IV.E.2. *Federal assistance to owners remaining in a floodplain.*

IV.E.2.a. *Prohibition on flood disaster assistance for failure to obtain and maintain flood insurance.* Grantees must comply with section 582 of the National Flood Insurance Reform Act of 1994, as amended, (42 U.S.C. 5154a), which prohibits flood disaster assistance in certain circumstances. No Federal disaster relief assistance made available in a flood disaster area may be used to make a payment (including any loan assistance payment) to a person for “repair, replacement, or restoration” for damage to any personal, residential, or commercial property if that person at any time has received Federal flood disaster assistance that was conditioned on the person first having obtained flood insurance under applicable Federal law and the person has subsequently failed to obtain and maintain flood insurance as required under applicable Federal law on such property.

A grantee may not provide disaster assistance for the repair, replacement, or restoration of a property to a person who has failed to satisfy the Federal requirement to obtain and maintain flood insurance and must implement a process to verify and monitor for compliance with section 582 and the requirement to obtain and maintain flood insurance. Grantees are reminded that CDBG–DR funds may be used to assist beneficiaries in the purchase of flood insurance to comply with this requirement, subject to the requirements of cost reasonableness and other federal cost principles.

IV.E.2.b. *Prohibition on flood disaster assistance for households above 120 percent of AMI for failure to obtain flood insurance.* When a homeowner located in the floodplain allows their flood insurance policy to lapse, it is assumed that the homeowner is unable to afford insurance and/or is accepting responsibility for future flood damage to the home. Higher income homeowners who reside in a floodplain, but who failed to secure or decided to not maintain their flood insurance, should not be assisted at the expense of lower income households. To ensure that adequate recovery resources are available to assist lower income homeowners who reside in a floodplain but who are unlikely to be able to afford flood insurance, the Secretary finds good cause to establish an alternative requirement.

The alternative requirement to 42 U.S.C. 5305(a)(4) is as follows: Grantees receiving CDBG–DR funds are prohibited from providing CDBG–DR assistance for the rehabilitation/reconstruction of a house, if (i) the combined household income is greater than either 120 percent of AMI or the national median, (ii) the property was located in a floodplain at the time of the disaster, and (iii) the property owner did not obtain flood insurance on the damaged property, even when the property owner was not required to obtain and maintain such insurance.

IV.E.2.c. *Responsibility to inform property owners to obtain and maintain flood insurance.* Section 582 of the National Flood Insurance Reform Act of 1994, as amended,

(42 U.S.C. 5154a) is a statutory requirement that property owners receiving disaster assistance that triggers the flood insurance purchase requirement have a statutory responsibility to notify any transferee of the requirement to obtain and maintain flood insurance and to maintain such written notification in the documents evidencing the transfer of the property, and that the transferring owner may be liable if he or she fails to do so. A grantee or subrecipient receiving CDBG–DR funds must notify property owners of their responsibilities under section 582.

#### *IV.F. URA, Section 104(d), and Related CDBG Program Requirements*

Activities and projects undertaken with CDBG–DR funds may be subject to the URA, section 104(d) of the HCDA (42 U.S.C. 5304(d)), and CDBG program requirements related to displacement, relocation, acquisition, and replacement of housing, except as modified by waivers and alternative requirements provided in this notice. The implementing regulations for the URA are at 49 CFR part 24. The regulations implementing section 104(d) are at 24 CFR part 42. The regulations for applicable CDBG program requirements are at 24 CFR 570.488 and 24 CFR 570.606. HUD is waiving or providing alternative requirements in this section for the purpose of promoting the availability of decent, safe, and sanitary housing with respect to the use of CDBG–DR funds allocated under the Consolidated Notice.

*IV.F.1. Section 104(d) one-for-one replacement of lower-income dwelling units.* One-for-one replacement requirements at section 104(d)(2)(A)(i) and (ii) and 104(d)(3) of the HCDA and 24 CFR 42.375 are waived for owner-occupied lower-income dwelling units that are damaged by the disaster and not suitable for rehabilitation. The section 104(d) one-for-one replacement housing requirements apply to occupied and vacant occupiable lower-income dwelling units demolished or converted in connection with a CDBG assisted activity. This waiver exempts all disaster-damaged owner-occupied lower-income dwelling units that meet the grantee's definition of "not suitable for rehabilitation," from the one-for-one replacement housing requirements of 24 CFR 42.375. Before carrying out activities that may be subject to the one-for-one replacement housing requirements, the grantee must define "not suitable for rehabilitation" in its action plan or in policies/procedures governing these activities. Grantees are reminded that tenant-occupied and vacant occupiable lower-income dwelling units demolished or converted to another use other than lower-income housing in connection with a CDBG–DR assisted activity are generally subject to one-for-one replacement requirements at 24 CFR 42.375 and that these provisions are not waived.

HUD is waiving the section 104(d) one-for-one replacement requirement for owner-occupied lower-income dwelling units that are damaged by the disaster and not suitable for rehabilitation because the one-for-one replacement requirements do not account for

the large, sudden changes that a major disaster may cause to the local housing stock, population, or economy. Disaster-damaged housing structures that are not suitable for rehabilitation can pose a threat to public health and safety and to economic revitalization. Prior to the implementation of this waiver and alternative requirement, grantees must reassess post-disaster population and housing needs to determine the appropriate type and amount of lower-income dwelling units (both rental and owner-occupied units) to rehabilitate and/or reconstruct. Grantees should note that the demolition and/or disposition of public housing units continue to be subject to section 18 of the United States Housing Act of 1937, as amended, and 24 CFR part 970.

*IV.F.2. Section 104(d) relocation assistance.* The relocation assistance requirements at section 104(d)(2)(A)(iii) and (B) of the HCDA and 24 CFR 42.350, are waived to the extent that an eligible displaced person, as defined under 24 CFR 42.305 of the section 104(d) implementing regulations, may choose to receive either assistance under the URA and implementing regulations at 49 CFR part 24, or assistance under section 104(d) and implementing regulations at 24 CFR 42.350. This waiver does not impact a person's eligibility as a displaced person under section 104(d), it merely limits the amounts and types of relocation assistance that a section 104(d) eligible displaced person is eligible to receive. A section 104(d) eligible displaced person is eligible to receive the amounts and types of assistance for displaced persons under the URA, as may be modified by the waivers and alternative requirements in this notice for activities related to disaster recovery. Without this waiver, disparities exist in relocation assistance associated with activities typically funded by HUD and FEMA (e.g., buyouts and relocation). Both FEMA and CDBG funds are subject to the requirements of the URA; however, CDBG funds are subject to section 104(d), while FEMA funds are not. This limited waiver of the section 104(d) relocation assistance requirements assures uniform and equitable treatment for individuals eligible to receive benefits under Section 104(d) by establishing that all forms of relocation assistance to those individuals must be in the amounts and for the types of assistance provided to displaced persons under URA requirements.

*IV.F.3. URA replacement housing payments for tenants.* The requirements of sections 204 and 205 of the URA (42 U.S.C. 4624 and 42 U.S.C. 4625), and 49 CFR 24.2(a)(6)(vii), 24.2(a)(6)(ix), and 24.402(b) are waived to the extent necessary to permit a grantee to meet all or a portion of a grantee's replacement housing payment obligation to a displaced tenant by offering rental housing through a rental housing program subsidy (to include, but not limited to, a housing choice voucher), provided that comparable replacement dwellings are made available to the tenant in accordance with 49 CFR 24.204(a) where the owner is willing to participate in the program and the period of authorized assistance is at least 42 months. This waiver and alternative requirement is subject to the following: If assistance is

provided through a HUD program, it is subject to the applicable HUD program requirements, including the requirement that the tenant must be eligible for the rental housing program. Failure to grant this waiver would impede disaster recovery whenever rental program subsidies are available but funds for cash replacement housing payments are limited and such payments are required by the URA to be based on a 42-month term.

*IV.F.4. URA voluntary acquisition—homebuyer primary residence purchase.* Grantees may implement disaster recovery program activities that provide financial assistance to eligible homebuyers to purchase and occupy residential properties as their primary residence. Such purchases are generally considered voluntary acquisitions under the URA and subject to the URA regulatory requirements at 49 CFR 24.101(b)(2). For CDBG–DR, 49 CFR 24.101(b)(2) is waived to the extent that it applies to a homebuyer, who does not have the power of eminent domain, and uses CDBG–DR funds in connection with the voluntary purchase and occupancy of a home the homebuyer intends to make their primary residence. This waiver is necessary to reduce burdensome administrative requirements for homebuyers following a disaster. Tenants displaced by these voluntary acquisitions may be eligible for relocation assistance.

*IV.F.5. CDBG displacement, relocation, acquisition, and replacement housing program regulations—Optional relocation assistance.* The regulations at 24 CFR 570.606(d) are waived to the extent that they require optional relocation policies to be established at the grantee level. Unlike with the regular CDBG program, states may carry out disaster recovery activities directly or through subrecipients, but 24 CFR 570.606(d) does not account for this distinction. This waiver makes clear that grantees receiving CDBG–DR funds may establish optional relocation policies or permit their subrecipients to establish separate optional relocation policies. The written policy must: be available to the public, describe the relocation assistance that the grantee, state recipient (*i.e.*, a local government receiving a subgrant from the state through a method of distribution), or subrecipient (as applicable) has elected to provide, and provide for equal relocation assistance within each class of displaced persons according to 24 CFR 570.606(d). This waiver is intended to provide states with maximum flexibility in developing optional relocation policies with CDBG–DR funds.

*IV.F.6. Waiver of Section 414 of the Stafford Act.* Section 414 of the Stafford Act (42 U.S.C. 5181) provides that "Notwithstanding any other provision of law, no person otherwise eligible for any kind of replacement housing payment under the Uniform Relocation Assistance and Real Property Acquisition Policies Act of 1970 (Pub. L. 91–646) [42 U.S.C. 4601 *et seq.*] ["URA"] shall be denied such eligibility as a result of his being unable, because of a major disaster as determined by the President, to meet the occupancy requirements set by [the URA]." Accordingly, homeowner occupants and tenants displaced from their homes as a

result of the identified disasters and who would have otherwise been displaced as a direct result of any acquisition, rehabilitation, or demolition of real property for a federally funded program or project may become eligible for a replacement housing payment notwithstanding their inability to meet occupancy requirements prescribed in the URA. Section 414 of the Stafford Act and its implementing regulation at 49 CFR 24.403(d)(1) are waived to the extent that they would apply to real property acquisition, rehabilitation, or demolition of real property for a CDBG-DR funded project commencing more than one year after the date of the latest applicable Presidentially declared disaster undertaken by the grantees, or subrecipients, provided that the project was not planned, approved, or otherwise underway before the disaster.

For purposes of this waiver, a CDBG-DR funded project shall be determined to have commenced on the earliest of: (1) The date of an approved Request for Release of Funds and certification; (2) the date of completion of the site-specific review when a program utilizes Tiering; or (3) the date of sign-off by the approving official when a project converts to exempt under 24 CFR 58.34(a)(12).

The waiver will simplify the administration of the disaster recovery process and reduce the administrative burden associated with the implementation of Stafford Act Section 414 requirements for projects commencing more than one year after the date of the Presidentially declared disaster considering most of such persons displaced by the disaster will have returned to their dwellings or found another place of permanent residence.

This waiver does not apply with respect to persons that meet the occupancy requirements to receive a replacement housing payment under the URA nor does it apply to persons displaced or relocated temporarily by other HUD-funded programs or projects. Such persons' eligibility for relocation assistance and payments under the URA is not impacted by this waiver.

**IV.F.7. RARAP Section 104(d).** CDBG-DR grantees must certify that they have in effect and are following a RARAP as required by section 104(d)(1) and (2) of the HCDA and 24 CFR 42.325. In addition to the requirements in 24 CFR 42.325 and 24 CFR 570.488 or 24 CFR 570.606(c), as applicable, HUD is specifying the following alternative requirements:

Grantees who are following an existing RARAP for CDBG purposes must either: (1) Amend their existing RARAP; or (2) create a separate RARAP for CDBG-DR purposes, to reflect the following requirements and applicable waivers and alternative requirements as modified by the Consolidated Notice.

Grantees who do not have an existing RARAP in place because they do not manage CDBG programs must create a separate RARAP for CDBG-DR purposes, to reflect the following CDBG-DR requirements and applicable waivers and alternative requirements as modified by the Consolidated Notice.

(1) RARAP requirements for CDBG-DR. As each grantee establishes and supports

feasible and cost-effective recovery efforts to make communities more resilient against future disasters, the CDBG-DR RARAP must describe how the grantee plans to minimize displacement of members of families and individuals from their homes and neighborhoods as a result of any CDBG-DR assisted activities, including disaster recovery activities where displacement can be prevented (e.g., housing rehabilitation programs). Across disaster recovery activities—such as buyouts and other eligible acquisition activities, where minimizing displacement is not reasonable, feasible, or cost-efficient and would not help prevent future or repetitive loss—the grantee must describe how it plans to minimize the adverse impacts of displacement.

The description shall focus on proposed disaster recovery activities that may directly or indirectly result in displacement and the assistance that shall be required for those displaced. This description must focus on relocation assistance under the URA and its implementing regulations at 49 CFR part 24, Section 104(d) and implementing regulations at 24 CFR part 42 (to the extent applicable), 24 CFR 570.488 and/or 24 CFR 570.606, and relocation assistance pursuant to this section of the Consolidated Notice, as well as any other assistance being made available to displaced persons. The CDBG-DR RARAP must include a description of how the grantee will plan programs or projects in such a manner that recognizes the substantial challenges experienced by displaced individuals, families, businesses, farms, and nonprofit organizations and develop solutions to minimize displacement or the adverse impacts of displacement especially among vulnerable populations. The description must be scoped to the complexity and nature of the anticipated displacing activities, including the evaluation of the grantee's available resources to carry out timely and orderly relocations in compliance with all applicable relocation requirements.

#### V. Performance Reviews

Under 42 U.S.C. 5304(e) and 24 CFR 1003.506(a), the Secretary shall, at least on an annual basis, make such reviews and audits as may be necessary or appropriate to determine whether the grantee has carried out its activities in a timely manner (consistent process to meet its expenditure requirement), whether the grantee's activities and certifications are carried out in accordance with the requirements and the primary objectives of the HCDA and other applicable laws, and whether the grantee has the continuing capacity to carry out those activities in a timely manner.

##### V.A. Timely Distribution and Expenditure of Funds

HUD waives the provisions at 24 CFR 570.494 and 24 CFR 570.902 regarding timely distribution and expenditure of funds, and establishes an alternative requirement providing that each grantee must expend 100 percent of its allocation within six years of the date HUD signs the grant agreement. HUD may extend the period of performance administratively, if good cause for such an extension exists at that time, as requested by

the grantee, and approved by HUD. When the period of performance has ended, HUD will close out the grant and any remaining funds not expended by the grantee on appropriate programmatic purposes will be recaptured by HUD.

##### V.B. Review of Continuing Capacity

Upon a determination by HUD that the grantee has not carried out its CDBG-DR activities and certifications in accordance with the requirements in the Consolidated Notice, HUD will undertake a further review to determine if the grantee has the continuing capacity to carry out its activities in a timely manner. In making this determination, HUD will consider the nature and extent of the recipient's performance deficiencies, the actions taken by the recipient to address the deficiencies, and the success or likely success of such actions. HUD may then apply the following corrective and remedial actions as appropriate:

**V.B.1. Corrective and remedial actions.** To effectively administer the CDBG-DR program in a manner that facilitates recovery, particularly the alternative requirements permitting states to act directly to carry out eligible activities, HUD is waiving 42 U.S.C. 5304(e) to the extent necessary to establish the following alternative requirement: HUD may undertake corrective and remedial actions for states in accordance with the authorities for CDBG Entitlement grantees in subpart O (including corrective and remedial actions in 24 CFR 570.910, 570.911, and 570.913) or under subpart I of the CDBG regulations at 24 CFR part 570. In response to a deficiency, HUD may issue a warning letter followed by a corrective action plan that may include a management plan which assigns responsibility for further administration of the grant to specific entities or persons. Failure to comply with a corrective action may result in the termination, reduction, or limitation of payments to grantees receiving CDBG-DR funds.

**V.B.2. Reduction, withdrawal, or adjustment of a grant, or other appropriate action.** Before a reduction, withdrawal, or adjustment of a CDBG-DR grant, or other actions taken pursuant to this section, the recipient shall be notified of the proposed action and be given an opportunity for an informal consultation. Consistent with the procedures described in the Consolidated Notice, HUD may adjust, reduce, or withdraw the CDBG-DR grant (except funds that have been expended for eligible, approved activities) or take other actions as appropriate.

**V.B.3. Additional criteria and specific conditions to mitigate risk.** To ensure effective grantee implementation of the financial controls, procurement processes, and other procedures that are the subject of the certification by the Secretary, HUD has and may continue to establish specific criteria and conditions for each grant award as provided for at 2 CFR 200.206 and 200.208, respectively, to mitigate the risk of the grant. The Secretary shall specify any such criteria and the resulting conditions in the grant conditions governing the award. These criteria may include, but need not be

limited to, a consideration of the internal control framework established by the grantee to ensure compliant implementation of its financial controls, procurement processes and payment of funds to eligible entities, as well as the grantee's risk management strategy for information technology systems established to implement CDBG-DR funded programs. Additionally, the Secretary may amend the grant conditions to mitigate risk of a grant award at any point at which the Secretary determines a condition to be required to protect the Federal financial interest or to advance recovery.

*V.C. Grantee Reporting Requirements in the DRGR System*

*V.C.1. DRGR-related waivers and alternative requirements.* The Consolidated Notice waives the requirements for submission of a performance report pursuant to 42 U.S.C. 12708(a), 24 CFR 91.520, and annual status and evaluation reports that are due each fiscal year under 24 CFR 1003.506(a). Alternatively, HUD is requiring that grantees enter information in the DRGR system on a quarterly basis through the performance reports. The information in DRGR and the performance reports must contain sufficient detail to permit HUD's

review of grantee performance and to enable remote review of grantee data to allow HUD to assess compliance and risk.

At a minimum, each grantee must:

a. Enter its action plan and amendments as described in III.C.1, including performance measures, into the Public Action Plan in DRGR;

b. Enter activities into the DRGR Action Plan at a level of detail sufficient to allow HUD to determine grantee compliance (when the activity type, national objective, and the organization that will be responsible for the activity is known);

c. Categorize activities in DRGR under a "project";

d. Enter into the DRGR system summary information on grantees' monitoring visits and reports, audits, and technical assistance it conducts as part of its oversight of its disaster recovery programs;

e. Use the DRGR system to draw grant funds for each activity;

f. Use the DRGR system to track program income receipts, disbursements, revolving loan funds, and leveraged funds (if applicable);

g. Submit a performance report through the DRGR system no later than 30 days following the end of each calendar quarter. For all

activities, the address of each CDBG-DR assisted property must be recorded in the performance report; and

h. Publish a version of the performance report that omits personally identifiable information reported in the performance reports submitted to HUD on the grantee's official website within three days of submission to HUD, or in the event a performance report is rejected by HUD, publish the revised version, as approved by HUD, within three days of HUD approval.

The grantee's first performance report is due after the first full quarter after HUD signs the grant agreement. Performance reports must be submitted on a quarterly basis until all funds have been expended and all expenditures and accomplishments have been reported. If a satisfactory report is not submitted in a timely manner, HUD may suspend access to CDBG-DR funds until a satisfactory report is submitted, or may withdraw and reallocate funding if HUD determines, after notice and opportunity for a hearing, that the jurisdiction did not submit a satisfactory report.

[FR Doc. 2022-02209 Filed 2-2-22; 8:45 am]

**BILLING CODE 4210-67-P**



# FEDERAL REGISTER

---

Vol. 87

Thursday,

No. 23

February 3, 2022

---

Part V

## The President

---

Proclamation 10336—American Heart Month, 2022

Proclamation 10337—National Black History Month, 2022

Proclamation 10338—National Teen Dating Violence Awareness and Prevention Month, 2022





## Title 3—

## Proclamation 10336 of January 31, 2022

## The President

## American Heart Month, 2022

## By the President of the United States of America

## A Proclamation

Heart disease is a leading cause of death in the United States, claiming the lives of more than 650,000 people each year. During American Heart Month, we raise awareness of the risks of heart disease, remember those we have lost, and highlight steps we can all take to save the lives of countless loved ones and address the unequal burden of heart disease in high-risk communities.

Through research and innovation, we have made considerable progress in recent years to advance our knowledge and treatment of heart disease. New technologies allow us to diagnose, prevent, and treat heart disease more rapidly and effectively than ever before. We also have a better understanding of heart disease risk factors, such as high blood pressure, bad cholesterol, smoking, being overweight or obese, and type 2 diabetes.

Despite the significant progress we have made, heart disease continues to exact a heartbreaking toll—a burden disproportionately carried by Black and brown Americans, American Indians and Alaska Natives, and people who live in rural communities. Cardiovascular diseases—including heart conditions and strokes—are also a leading cause of pregnancy-related deaths, which are highest among women of color. Addressing these tragic disparities and improving heart health has never been more important, as people suffering from heart disease and related conditions are also at increased risk of severe illness and long-term effects from COVID-19.

My Administration is committed to supporting Americans in their efforts to achieve better heart health, as well as closing the racial gaps in cardiovascular disease. That is why I have asked the Congress to launch a major new initiative—the Advanced Research Projects Agency for Health, or ARPA-H—which would invest billions of dollars in preventing, detecting, and treating cancer, cardiovascular conditions, and other deadly diseases. My Administration is also working across Federal agencies to develop new programs to alleviate heart health disparities, including those that threaten maternal health.

Engaging in regular physical activity, maintaining a healthy diet and weight, managing stress, avoiding smoking and vaping, and getting quality sleep each night can all reduce the risk of heart disease and help people live longer, healthier lives. While it is essential to see a health care professional if you have symptoms or risk factors related to heart disease, research shows that taking a little time each day to promote a healthy lifestyle can help improve your long-term heart health.

On Friday, February 4th—National Wear Red Day—we honor those we have lost to heart disease and raise awareness of the actions we can all take to prevent it. The First Lady and I encourage all Americans to observe this important day. Continuing the fight against cardiovascular disease is crucial to improving our Nation's public health. During American Heart Month, we must recommit ourselves to ensuring a healthier future for all Americans.

In acknowledgement of the importance of the ongoing fight against cardiovascular disease, the Congress, by Joint Resolution approved December 30, 1963, as amended (36 U.S.C. 101), has requested that the President issue an annual proclamation designating February as "American Heart Month."

NOW, THEREFORE, I, JOSEPH R. BIDEN JR., President of the United States of America, do hereby proclaim February 2022 as American Heart Month, and I invite all Americans to participate in National Wear Red Day on February 4, 2022. I also invite the Governors of the States, the Commonwealth of Puerto Rico, officials of other areas subject to the jurisdiction of the United States, and the American people to join me in recognizing and reaffirming our commitment to fighting cardiovascular disease.

IN WITNESS WHEREOF, I have hereunto set my hand this thirty-first day of January, in the year of our Lord two thousand twenty-two, and of the Independence of the United States of America the two hundred and forty-sixth.

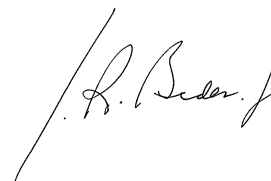

## Presidential Documents

**Proclamation 10337 of January 31, 2022**

**National Black History Month, 2022**

**By the President of the United States of America**

### **A Proclamation**

Each February, National Black History Month serves as both a celebration and a powerful reminder that Black history is American history, Black culture is American culture, and Black stories are essential to the ongoing story of America—our faults, our struggles, our progress, and our aspirations. Shining a light on Black history today is as important to understanding ourselves and growing stronger as a Nation as it has ever been. That is why it is essential that we take time to celebrate the immeasurable contributions of Black Americans, honor the legacies and achievements of generations past, reckon with centuries of injustice, and confront those injustices that still fester today.

Our Nation was founded on an idea: that all of us are created equal and deserve to be treated with equal dignity throughout our lives. It is a promise we have never fully lived up to but one that we have never, ever walked away from. The long shadows of slavery, Jim Crow, and redlining—and the blight of systemic racism that still diminishes our Nation today—hold America back from reaching our full promise and potential. But by facing those tragedies openly and honestly and working together as one people to deliver on America's promise of equity and dignity for all, we become a stronger Nation—a more perfect version of ourselves.

Across the generations, countless Black Americans have demonstrated profound moral courage and resilience to help shape our Nation for the better. Today, Black Americans lead industries and movements for change, serve our communities and our Nation at every level, and advance every field across the board, including arts and sciences, business and law, health and education, and many more. In the face of wounds and obstacles older than our Nation itself, Black Americans can be seen in every part of our society today, strengthening and uplifting all of America.

Vice President Harris and I are deeply committed to advancing equity, racial justice, and opportunity for Black Americans as we continue striving to realize America's founding promise. That began by building a Federal Government that looks like America: including the first Black Secretary of Defense, the first Black woman to head the Office of Management and Budget, the first Black man to lead the Environmental Protection Agency, the first Black woman to lead the Department of Housing and Urban Development in more than 40 years, the first Black chair of the White House Council of Economic Advisors, a Black Ambassador representing America at the United Nations, and the first Black and South Asian Vice President in our history. We have been proud to appoint accomplished Black Americans to serve in a vast array of roles across our Administration. I am prouder still to have already nominated eight Black women to serve as Federal appellate judges—matching in just 1 year the total number of Black women who have ever served on Federal appeals courts.

My Administration has worked hard to reverse decades of underinvestment in Black communities, schools, and businesses. Both the American Rescue Plan and the Bipartisan Infrastructure Law are making historic investments in Black America—from vaccine shots in arms to checks in families' pockets

and tax cuts for working families with children to a landmark \$5.8 billion investment in and support for Historically Black Colleges and Universities. And in my first year in office, the American Rescue Plan provided the full Child Tax Credit to the lower income families of more than 26 million children—who are disproportionately Black—and put us on a path to cut Black child poverty in half.

As the Infrastructure Law continues to be implemented, we will expand on that progress. Lead service lines that have contaminated the water of too many homes and schools in Black communities will be removed and replaced. We will deliver high-speed internet to every community so that no Black family is left behind in the 21st century economy. Historic investments in public transportation will help more people in more neighborhoods get to where good jobs actually are quickly and safely. We will reconnect Black neighborhoods cut off from opportunity by highways that were built to brush them aside. Long-standing environmental injustices that have hit Black communities the hardest will be remediated. We will deliver major investments in Black entrepreneurs and small businesses—including making the Minority Business Development Agency permanent and seeding it with a record \$110 million in new resources to help level the playing field for Black businesses.

But this is only the start. To fulfill America's promise for all, we will work tirelessly in the year ahead to deliver on my Build Back Better agenda, bringing down the costs that families face on child care, housing, education, health care, prescription drugs, and so much more. We will continue to battle the COVID-19 pandemic with equity at the center of our response. We will not rest until we have protected the foundation of our democracy: the sacred right to vote. And we will fight to keep dismantling all of those structural inequities that have served as barriers for Black families for generations.

As we celebrate National Black History Month, let us all recommit ourselves to reach for that founding promise. Let us continue to fight for the equity, opportunity, and dignity to which every Black American is due in equal measure. Let us carry forward the work to build an America that is, in the beautiful words of the poet Amanda Gorman, "*Bruised, but whole—benevolent, but bold, fierce, and free.*"

NOW, THEREFORE, I, JOSEPH R. BIDEN JR., President of the United States of America, by virtue of the authority vested in me by the Constitution and the laws of the United States, do hereby proclaim February 2022 as National Black History Month. I call upon public officials, educators, librarians, and all the people of the United States to observe this month with appropriate programs, ceremonies, and activities.

IN WITNESS WHEREOF, I have hereunto set my hand this thirty-first day of January, in the year of our Lord two thousand twenty-two, and of the Independence of the United States of America the two hundred and forty-sixth.

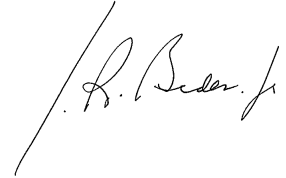
A handwritten signature in black ink, appearing to read "Joe Biden", written in a cursive style.

---

## Presidential Documents

**Proclamation 10338 of January 31, 2022**

### **National Teen Dating Violence Awareness and Prevention Month, 2022**

**By the President of the United States of America**

#### **A Proclamation**

During National Teen Dating Violence Awareness and Prevention Month, we recommit ourselves to ensuring our society is one in which all young people can live fulfilling and productive lives free of violence and fear.

Teen dating violence takes many forms, including physical or sexual assault, stalking, coercive and controlling behavior, emotional abuse, harassment, and exploitation. It can occur in person, online, or through various forms of technology. Centers for Disease Control and Prevention research shows that more than 8 percent of high school students in the United States reported experiencing physical or sexual dating violence over the course of a 1-year period, with young women and LGBTQI+ youth facing the highest rates. Young people who are survivors of teen dating violence can suffer from depression, substance abuse, risk of suicide, eating disorders, poor academic outcomes, unintended pregnancy, and other struggles. Sadly, survivors of teenage dating violence are more likely to be revictimized as adults. These effects are compounded for girls and young women of color, who are less often recognized as survivors of dating and sexual violence and face additional barriers to seeking help.

My Administration is committed to supporting programs that are proven to help preteens and teens develop safe and healthy relationships. We have released a range of new resources to equip communities with effective tools to prevent and address teen dating violence. These tools will help teens stay safe online and when they use electronic devices; help colleges and universities respond effectively to dating violence, sexual assault, stalking and other forms of abuse; and provide resources and training programs that prevent abuse and promote healthy relationships. Information on these programs, as well as other resources, are available at [VetoViolence.CDC.gov](https://VetoViolence.CDC.gov). We are also enforcing Title IX's protections for students on the basis of gender identity and sexual orientation to support transgender students who experience higher rates of violence.

During National Teen Dating Violence Awareness and Prevention Month, we recommit ourselves to ending this scourge of our society and providing our young people every chance to live the fulfilling and productive lives they deserve.

NOW, THEREFORE, I, JOSEPH R. BIDEN JR., President of the United States of America, by virtue of the authority vested in me by the Constitution and the laws of the United States, do hereby proclaim February 2022 as National Teen Dating Violence Awareness and Prevention Month. I call upon everyone to educate themselves and others about teen dating violence so that together we can stop it.

IN WITNESS WHEREOF, I have hereunto set my hand this thirty-first day of January, in the year of our Lord two thousand twenty-two, and of the Independence of the United States of America the two hundred and forty-sixth.

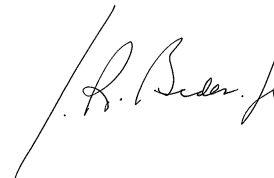
A handwritten signature in black ink, appearing to read "Joe Biden", written in a cursive style.



# Reader Aids

Federal Register

Vol. 87, No. 23

Thursday, February 3, 2022

## CUSTOMER SERVICE AND INFORMATION

### Federal Register/Code of Federal Regulations

General Information, indexes and other finding aids **202-741-6000**

**Laws** **741-6000**

### Presidential Documents

Executive orders and proclamations **741-6000**

**The United States Government Manual** **741-6000**

### Other Services

Electronic and on-line services (voice) **741-6020**

Privacy Act Compilation **741-6050**

## ELECTRONIC RESEARCH

### World Wide Web

Full text of the daily Federal Register, CFR and other publications is located at: [www.govinfo.gov](http://www.govinfo.gov).

Federal Register information and research tools, including Public Inspection List and electronic text are located at: [www.federalregister.gov](http://www.federalregister.gov).

### E-mail

**FEDREGTOC** (Daily Federal Register Table of Contents Electronic Mailing List) is an open e-mail service that provides subscribers with a digital form of the Federal Register Table of Contents. The digital form of the Federal Register Table of Contents includes HTML and PDF links to the full text of each document.

To join or leave, go to <https://public.govdelivery.com/accounts/USGPOOFR/subscriber/new>, enter your email address, then follow the instructions to join, leave, or manage your subscription.

**PENS** (Public Law Electronic Notification Service) is an e-mail service that notifies subscribers of recently enacted laws.

To subscribe, go to <http://listserv.gsa.gov/archives/publaws-l.html> and select *Join or leave the list (or change settings)*; then follow the instructions.

**FEDREGTOC** and **PENS** are mailing lists only. We cannot respond to specific inquiries.

**Reference questions.** Send questions and comments about the Federal Register system to: [fedreg.info@nara.gov](mailto:fedreg.info@nara.gov)

The Federal Register staff cannot interpret specific documents or regulations.

## FEDERAL REGISTER PAGES AND DATE, FEBRUARY

5389-5654..... 1  
5655-6016..... 2  
6017-6402..... 3

## CFR PARTS AFFECTED DURING FEBRUARY

At the end of each month the Office of the Federal Register publishes separately a List of CFR Sections Affected (LSA), which lists parts and sections affected by documents published since the revision date of each title.

### 3 CFR

**Proclamations:**  
10336.....6395  
10337.....6397  
10338.....6401

### 5 CFR

**Proposed Rules:**  
Ch. III.....5409

### 7 CFR

**Proposed Rules:**  
205.....5424

### 8 CFR

214.....6017  
274a.....6017

### 10 CFR

**Proposed Rules:**  
429.....5560  
430.....5742  
431.....5560

### 12 CFR

**Proposed Rules:**  
701.....6078

### 14 CFR

25.....6017  
39.....5389, 5391  
97.....6019, 6021  
399.....5655  
**Proposed Rules:**  
39.....5428, 6082, 6087, 6089,  
6091  
71.....5747

### 15 CFR

734.....6022  
736.....6022  
744.....6022  
774.....6022

### 16 CFR

**Proposed Rules:**  
1112.....6246  
1261.....6246

### 17 CFR

**Proposed Rules:**  
229.....5751  
240.....5751  
249.....5751

### 18 CFR

381.....5659

### 20 CFR

655.....6017  
**Proposed Rules:**  
220.....6094

### 21 CFR

1.....5660

### 22 CFR

**Proposed Rules:**  
120.....5759  
126.....5759  
127.....5759

### 29 CFR

2702.....5393

### 33 CFR

100.....6026  
117.....5401  
127.....5660  
165.....6031

### Proposed Rules:

100.....5430

### 34 CFR

**Proposed Rules:**  
Ch. III.....5432

### 36 CFR

7.....5402  
1155.....5692  
1195.....6037

### 38 CFR

1.....5693  
3.....6038

### 40 CFR

80.....5696  
180.....5703, 5709, 6039

### Proposed Rules:

52.....5435, 5438, 5761, 6095  
81.....5438  
87.....6324  
271.....5450  
1030.....6324  
1031.....6324

### 41 CFR

102-35.....6042  
102-37.....6042  
102-77.....5711

### 47 CFR

73.....6043

### Proposed Rules:

73.....6100

### 48 CFR

332.....5717  
352.....5717  
538.....6044  
552.....6044

### 49 CFR

219.....5719

383.....6045	635.....5737	<b>Proposed Rules:</b>	20.....5946
<b>50 CFR</b>	648.....5405, 5739	17.....5767, 6101, 6118	
17.....5737, 6046, 6063			

---

**LIST OF PUBLIC LAWS**

---

This is a continuing list of public bills from the current session of Congress which have become Federal laws. This list is also available online at <https://www.archives.gov/federal-register/laws>.

The text of laws is not published in the **Federal Register** but may be ordered in "slip law" (individual pamphlet) form from the Superintendent of Documents, U.S. Government Publishing Office, Washington, DC 20402 (phone, 202-512-1808). The text will also be made available at <https://www.govinfo.gov>. Some laws may not yet be available.

**S. 452/P.L. 117-84**  
Willie O'Ree Congressional Gold Medal Act (Jan. 31, 2022; 136 Stat. 8)  
Last List January 24, 2022

---

**Public Laws Electronic Notification Service (PENS)**

---

**PENS** is a free email notification service of newly

enacted public laws. To subscribe, go to <https://listserv.gsa.gov/cgi-bin/wa.exe?SUBED1=PUBLAWS-L&A=1>

**Note:** This service is strictly for email notification of new laws. The text of laws is not available through this service. **PENS** cannot respond to specific inquiries sent to this address.