

PROGRAM TITLE	2554-S TERM: Date of Award through 05/31/2024 + 1 option year IRS E-178 Envelopes	BASIS OF AWARD	Cenveo Cleve., OH & Cty. of Ind., CA		Envelope 1, Inc. Columbiana, OH	
ITEM NO.	DESCRIPTION		UNIT RATE	COST	UNIT RATE	COST
I.	Proofs and Prior-to-Production Samples:					
(a)	PDF Proofs, per PDF proof	2	\$0.00	\$0.00	NC	\$0.00
(b)	Prior-to-Production Samples (2,500 samples per set), per set	2	\$0.00	\$0.00	NC	\$0.00
II.	Printing/Construction:					
(a)	Quantities of 10,000 to 100,000 envelopes, per order:					
(1)	Makeready and/or Setup	10	\$0.00	\$0.00	NC	\$0.00
(2)	Running per 1,000 Envelopes	550	\$14.05	\$7,727.50	\$10.62	\$5,841.00
(b)	Quantities of 100,001 to 1,000,000 envelopes, per order:					
(1)	Makeready and/or Setup	5	\$0.00	\$0.00	NC	\$0.00
(2)	Running per 1,000 Envelopes	1,333	\$14.05	\$18,728.65	\$10.62	\$14,156.46
(c)	Quantities of 1,000,000 to 20,00,000 envelopes, per order:					
(1)	Makeready and/or Setup	24	\$0.00	\$0.00	NC	\$0.00
(2)	Running per 1,000 Envelopes	253,500	\$14.05	\$3,561,675.00	\$10.62	\$2,692,170.00
III.	Stock/Paper:					
(a)	E-178 and E-178-2 Envelopes, per 1,000 envelopes	255,383	\$9.45	\$2,413,369.35	\$9.92	\$2,533,399.36
IV.	Packing and Shipping Charges:					
(a)	Deliver to Ogden, Utah, per 1,000 envelopes	123,681	\$2.58	\$319,096.98	\$3.15	\$389,595.15
(b)	Deliver to Austin, Texas, per 1,000 envelopes	10	\$7.02	\$70.20	\$2.43	\$24.30
(c)	Deliver to Kansas City, Missouri, per 1,000 envelopes	22	\$8.80	\$193.60	\$2.05	\$45.10
(d)	Deliver to Bloomington, Illinois, per 1,000 envelopes	4,552	\$4.92	\$22,395.84	\$1.51	\$6,873.52
(e)	Deliver to Detroit, Michigan, per 1,000 envelopes	123,117	\$0.77	\$94,800.09	\$1.32	\$162,514.44
(f)	Deliver to Cincinnati, Ohio, per 1,000 envelopes	101	\$9.96	\$1,005.96	\$1.37	\$138.37
(g)	Deliver to Kearneysville, West Virginia, per 1,000 envelopes	3,900	\$7.69	\$29,991.00	\$1.39	\$5,421.00
SUBTOTAL				\$6,469,054.17		\$5,810,178.70
PROMPT PAYMENT DISCOUNT			NET	\$0.00	2.00%	\$0.00
DISCOUNTED TOTALS				\$6,469,054.17	10 Days	\$5,810,178.70

Abstracted by: Linda Price 05/10/2023

Verified by: Russ Woodmancy 05/11/2023

PROGRAM TITLE	2554-S TERM: Date of Award through 05/31/2024 + 1 option year IRS E-178 Envelopes	BASIS OF AWARD	Envelope Printery Van Buren Township, MI		Husky Envelope Walled Lake, MI	
ITEM NO.	DESCRIPTION		UNIT RATE	COST	UNIT RATE	COST
I.	Proofs and Prior-to-Production Samples:					
(a)	PDF Proofs, per PDF proof	2	\$0.00	\$0.00	NC	\$0.00
(b)	Prior-to-Production Samples (2,500 samples per set), per set	2	\$0.02	\$0.04	NC	\$0.00
II.	Printing/Construction:					
(a)	Quantities of 10,000 to 100,000 envelopes, per order:					
(1)	Makeready and/or Setup	10	\$2.79	\$27.90	NC	\$0.00
(2)	Running per 1,000 Envelopes	550	\$12.17	\$6,693.50	\$26.94	\$14,817.00
(b)	Quantities of 100,001 to 1,000,000 envelopes, per order:					
(1)	Makeready and/or Setup	5	\$0.60	\$3.00	NC	\$0.00
(2)	Running per 1,000 Envelopes	1,333	\$11.97	\$15,956.01	\$14.22	\$18,955.26
(c)	Quantities of 1,000,000 to 20,00,000 envelopes, per order:					
(1)	Makeready and/or Setup	24	\$0.28	\$6.72	NC	\$0.00
(2)	Running per 1,000 Envelopes	253,500	\$11.77	\$2,983,695.00	\$13.04	\$3,305,640.00
III.	Stock/Paper:					
(a)	E-178 and E-178-2 Envelopes, per 1,000 envelopes	255,383	\$11.53	\$2,944,565.99	\$11.71	\$2,990,534.93
IV.	Packing and Shipping Charges:					
(a)	Deliver to Ogden, Utah, per 1,000 envelopes	123,681	\$3.08	\$380,937.48	\$1.95	\$241,177.95
(b)	Deliver to Austin, Texas, per 1,000 envelopes	10	\$7.29	\$72.90	\$4.00	\$40.00
(c)	Deliver to Kansas City, Missouri, per 1,000 envelopes	22	\$3.75	\$82.50	\$2.50	\$55.00
(d)	Deliver to Bloomington, Illinois, per 1,000 envelopes	4,552	\$2.87	\$13,064.24	\$2.00	\$9,104.00
(e)	Deliver to Detroit, Michigan, per 1,000 envelopes	123,117	\$0.29	\$35,703.93	\$0.40	\$49,246.80
(f)	Deliver to Cincinnati, Ohio, per 1,000 envelopes	101	\$2.40	\$242.40	\$1.85	\$186.85
(g)	Deliver to Kearneysville, West Virginia, per 1,000 envelopes	3,900	\$3.60	\$14,040.00	\$2.20	\$8,580.00
SUBTOTAL				\$6,395,091.61		\$6,638,337.79
PROMPT PAYMENT DISCOUNT			1.00%	\$0.00	NET	\$0.00
DISCOUNTED TOTALS			10 Days	\$6,395,091.61		\$6,638,337.79

Abstracted by: Linda Price 05/10/2023
Verified by: Russ Woodmancy 05/11/2023

PROGRAM TITLE	2554-S TERM: Date of Award through 05/31/2024 + 1 option year IRS E-178 Envelopes	BASIS OF AWARD	J.J. Collins Printers Charleston, IL		Mac Paper Converters Jacksonville, FL	
ITEM NO.	DESCRIPTION		UNIT RATE	COST	UNIT RATE	COST
I.	Proofs and Prior-to-Production Samples:					
(a)	PDF Proofs, per PDF proof	2	NC	\$0.00	\$0.00	\$0.00
(b)	Prior-to-Production Samples (2,500 samples per set), per set	2	NC	\$0.00	\$0.00	\$0.00
II.	Printing/Construction:					
(a)	Quantities of 10,000 to 100,000 envelopes, per order:					
(1)	Makeready and/or Setup	10	NC	\$0.00	\$0.00	\$0.00
(2)	Running per 1,000 Envelopes	550	\$18.71	\$10,290.50	\$9.67	\$5,318.50
(b)	Quantities of 100,001 to 1,000,000 envelopes, per order:					
(1)	Makeready and/or Setup	5	NC	\$0.00	\$0.00	\$0.00
(2)	Running per 1,000 Envelopes	1,333	\$10.81	\$14,409.73	\$9.67	\$12,890.11
(c)	Quantities of 1,000,000 to 20,00,000 envelopes, per order:					
(1)	Makeready and/or Setup	24	NC	\$0.00	\$0.00	\$0.00
(2)	Running per 1,000 Envelopes	253,500	\$9.49	\$2,405,715.00	\$9.67	\$2,451,345.00
III.	Stock/Paper:					
(a)	E-178 and E-178-2 Envelopes, per 1,000 envelopes	255,383	\$9.49	\$2,423,584.67	\$11.45	\$2,924,135.35
IV.	Packing and Shipping Charges:					
(a)	Deliver to Ogden, Utah, per 1,000 envelopes	123,681	\$1.83	\$226,336.23	\$1.66	\$205,310.46
(b)	Deliver to Austin, Texas, per 1,000 envelopes	10	\$4.22	\$42.20	\$0.73	\$7.30
(c)	Deliver to Kansas City, Missouri, per 1,000 envelopes	22	\$2.66	\$58.52	\$0.69	\$15.18
(d)	Deliver to Bloomington, Illinois, per 1,000 envelopes	4,552	\$1.65	\$7,510.80	\$0.73	\$3,322.96
(e)	Deliver to Detroit, Michigan, per 1,000 envelopes	123,117	\$0.66	\$81,257.22	\$0.73	\$89,875.41
(f)	Deliver to Cincinnati, Ohio, per 1,000 envelopes	101	\$2.04	\$206.04	\$0.65	\$65.65
(g)	Deliver to Kearneysville, West Virginia, per 1,000 envelopes	3,900	\$3.51	\$13,689.00	\$0.59	\$2,301.00
SUBTOTAL				\$5,183,099.91		\$5,694,586.92
PROMPT PAYMENT DISCOUNT			NET	\$0.00	NET	\$0.00
DISCOUNTED TOTALS				\$5,183,099.91		\$5,694,586.92
Awarded Contractor						

Abstracted by: Linda Price 05/10/2023
Verified by: Russ Woodmancy 05/11/2023

PROGRAM TITLE	2554-S TERM: Date of Award through 05/31/2024 + 1 option year IRS E-178 Envelopes	BASIS OF AWARD	Printing Resources Cleveland, OH		Real Est. Img. dba Adv. Img. Dir. Fullerton, CA	
			UNIT RATE	COST	UNIT RATE	COST
I.	Proofs and Prior-to-Production Samples:					
(a)	PDF Proofs, per PDF proof	2	NC	\$0.00	\$0.00	\$0.00
(b)	Prior-to-Production Samples (2,500 samples per set), per set	2		\$2,500.00	\$5,000.00	\$0.00
II.	Printing/Construction:					
(a)	Quantities of 10,000 to 100,000 envelopes, per order:					
(1)	Makeready and/or Setup	10	NC	\$0.00	\$0.00	\$0.00
(2)	Running per 1,000 Envelopes	550		\$45.00	\$24,750.00	\$10.50
(b)	Quantities of 100,001 to 1,000,000 envelopes, per order:					
(1)	Makeready and/or Setup	5	NC	\$0.00	\$0.00	\$0.00
(2)	Running per 1,000 Envelopes	1,333		\$27.90	\$37,190.70	\$10.50
(c)	Quantities of 1,000,000 to 20,00,000 envelopes, per order:					
(1)	Makeready and/or Setup	24	NC	\$0.00	\$0.00	\$0.00
(2)	Running per 1,000 Envelopes	253,500		\$26.90	\$6,819,150.00	\$10.50
III.	Stock/Paper:					
(a)	E-178 and E-178-2 Envelopes, per 1,000 envelopes	255,383		\$16.80	\$4,290,434.40	\$11.00
IV.	Packing and Shipping Charges:					
(a)	Deliver to Ogden, Utah, per 1,000 envelopes	123,681		\$6.97	\$862,056.57	\$1.30
(b)	Deliver to Austin, Texas, per 1,000 envelopes	10		\$6.47	\$64.70	\$1.30
(c)	Deliver to Kansas City, Missouri, per 1,000 envelopes	22		\$4.89	\$107.58	\$1.80
(d)	Deliver to Bloomington, Illinois, per 1,000 envelopes	4,552		\$3.85	\$17,525.20	\$2.10
(e)	Deliver to Detroit, Michigan, per 1,000 envelopes	123,117		\$3.07	\$377,969.19	\$2.25
(f)	Deliver to Cincinnati, Ohio, per 1,000 envelopes	101		\$2.75	\$277.75	\$2.25
(g)	Deliver to Kearneysville, West Virginia, per 1,000 envelopes	3,900		\$4.62	\$18,018.00	\$3.00
SUBTOTAL					\$12,452,544.09	
PROMPT PAYMENT DISCOUNT				NET	\$0.00	NET
DISCOUNTED TOTALS					\$12,452,544.09	\$5,950,072.10

Abstracted by: Linda Price 05/10/2023
Verified by: Russ Woodmancy 05/11/2023

PROGRAM TITLE	2554-S TERM: Date of Award through 05/31/2024 + 1 option year IRS E-178 Envelopes	BASIS OF AWARD	Southland Envelope Lakeside, CA	
			UNIT RATE	COST
ITEM NO.	DESCRIPTION			
I.	Proofs and Prior-to-Production Samples:			
(a)	PDF Proofs, per PDF proof	2	\$0.00	\$0.00
(b)	Prior-to-Production Samples (2,500 samples per set), per set	2	\$250.00	\$500.00
II.	Printing/Construction:			
(a)	Quantities of 10,000 to 100,000 envelopes, per order:			
(1)	Makeready and/or Setup	10	\$200.00	\$2,000.00
(2)	Running per 1,000 Envelopes	550	\$11.00	\$6,050.00
(b)	Quantities of 100,001 to 1,000,000 envelopes, per order:			
(1)	Makeready and/or Setup	5	\$200.00	\$1,000.00
(2)	Running per 1,000 Envelopes	1,333	\$11.00	\$14,663.00
(c)	Quantities of 1,000,000 to 20,00,000 envelopes, per order:			
(1)	Makeready and/or Setup	24	\$200.00	\$4,800.00
(2)	Running per 1,000 Envelopes	253,500	\$11.00	\$2,788,500.00
III.	Stock/Paper:			
(a)	E-178 and E-178-2 Envelopes, per 1,000 envelopes	255,383	\$17.00	\$4,341,511.00
IV.	Packing and Shipping Charges:			
(a)	Deliver to Ogden, Utah, per 1,000 envelopes	123,681	\$1.37	\$169,442.97
(b)	Deliver to Austin, Texas, per 1,000 envelopes	10	\$1.58	\$15.80
(c)	Deliver to Kansas City, Missouri, per 1,000 envelopes	22	\$1.75	\$38.50
(d)	Deliver to Bloomington, Illinois, per 1,000 envelopes	4,552	\$1.91	\$8,694.32
(e)	Deliver to Detroit, Michigan, per 1,000 envelopes	123,117	\$2.08	\$256,083.36
(f)	Deliver to Cincinnati, Ohio, per 1,000 envelopes	101	\$1.91	\$192.91
(g)	Deliver to Kearneysville, West Virginia, per 1,000 envelopes	3,900	\$2.45	\$9,555.00
SUBTOTAL				\$7,603,046.86
PROMPT PAYMENT DISCOUNT			1.00%	\$76,030.47
DISCOUNTED TOTALS			20 Days	\$7,527,016.39

Abstracted by: Linda Price 05/10/2023

Verified by: Russ Woodmancy 05/11/2023

U.S. GOVERNMENT PUBLISHING OFFICE

Northeast Region

GENERAL TERMS, CONDITIONS, AND SPECIFICATIONS

For the Procurement of

IRS E-178 Envelopes

as requisitioned from the U.S. Government Publishing Office (GPO) by the

Internal Revenue Service

Single Award

TERM OF CONTRACT

The term of this contract is for 1 year (base year period of Date of Award through May 31, 2024) and 1 option year periods (June 1, 2024 through May 31, 2025). Special attention is directed to the following provision and clauses in Section 1 of this contract: “Option to Extend Term of Contract”, and “Economic Price Adjustment.”

BID OPENING

Bids shall be opened at 11:00 a.m., prevailing Columbus, Ohio time, on **May 10, 2023**.

BID SUBMISSION

Bidders MUST submit email bids to bidsnortheast@gpo.gov for this solicitation. No other method of bid submission will be accepted at this time.

The company name, program number, and bid opening date must be specified in the subject line of the emailed bid submission. Bids received after 11:00 a.m. prevailing Columbus, OH time on the bid opening date specified above will not be considered for award.

NOTICE TO BIDDERS

Significant revisions have been made throughout these specifications. Bidders are cautioned to familiarize themselves with all provisions of this contract before bidding.

Special attention is directed to the bid submission provisions under “Additional Emailed Bid Submission Provisions” on page 6.

Abstract of bids for Program 2554-S available at: <https://www.gpo.gov/how-to-work-with-us/vendors/contract-pricing>.

For information of a technical nature contact Linda Price at lprice@gpo.gov or (614) 488-4616, ext. 7 (no collect calls).

SECTION 1. – GENERAL TERMS AND CONDITIONS

GPO CONTRACT TERMS

Any contract which results from this Invitation for Bid will be subject to the applicable provisions, clauses, and supplemental specifications of GPO Contract Terms (GPO Pub. 310.2, effective December 1, 1987 (Rev. 1-18)) and GPO Contract Terms, Quality Assurance Through Attributes Program for Printing and Binding (GPO Pub. 310.1, effective May 1979 (Rev. 09-19)).

GPO Contract Terms (GPO Publication 310.2): <https://www.gpo.gov/docs/default-source/forms-and-standards-files-for-vendors/contractterms2018.pdf>

GPO QATAP (GPO Publication 310.1): <https://www.gpo.gov/docs/default-source/forms-and-standards-files-for-vendors/qatap-rev-09-19.pdf>.

More GPO Publications can be found at: <https://www.gpo.gov/how-to-work-with-us/vendors/forms-and-standards>

SUBCONTRACTING

The predominant production function is the manufacture of the envelopes and the printing of the envelopes. Bidders who must subcontract these operations may be declared non-responsible.

QUALITY ASSURANCE LEVELS AND STANDARDS

The following levels and standards shall apply to these specifications:

Product Quality Levels:

- (a) Printing (page related) Attributes -- Level IV.
- (b) Finishing (item related) Attributes -- Level IV.

Inspection Levels (from ANSI/ASQC Z 1.4):

- (a) Non-destructive Tests - General Inspection Level I.
- (b) Destructive Tests - Special Inspection Level S-2.

Specified Standards: The specified standards for the attributes requiring them shall be:

<u>Attribute</u>	<u>Specified Standard</u>
P-7. Type Quality and Uniformity	Average Type Dimension/PDF Proofs/Pre-Production Samples
P-9. Solid and Screen Tint Color Match	Pantone Matching System

CONTRACTOR'S QUALITY CONTROL PROCEDURES

The contractor shall, prior to start-up, put into effect within his own organization, and maintain throughout the life of this contract, an independent quality assurance organization.

This unit shall be of sufficient size and expertise to monitor, perform, or have performed the process controls, inspections, and tests necessary to assure that production and delivery of envelopes meets these specifications and Government requirements.

The contractor shall be required to correct each defect or error found during the inspection of work either in process or completed.

The contractor shall submit in writing to the Contracting Office, within 2 workdays after request by GPO, the details of their Quality Control Program. The proposed program is subject to Government approval.

This program shall, at a minimum, address the following:

1. Where and by whom daily process controls and inspections will be performed. Contractor shall state the number of people and the assignments that shall be permanently assigned to this program.
2. Appointment of an official or officials who shall be responsible for both the operation of the quality control system/department and for investigating and ascertaining the causes of defects/deficiencies found during production and in envelopes shipped, as reported by IRS.
3. How and when daily inspection and tests or reviews will be held to check for:
 - a. correct addressing;
 - b. acceptable printing, and
 - c. size, squareness, and parallel measurements.
4. Actions that will be taken when defects/deficiencies are detected.

Failure to maintain the Quality Control Program in accordance with the plan submitted and approved by the Government may result in the Government's termination of the contract for default.

OPTION TO EXTEND TERM OF CONTRACT

The Government has the option to extend the term of this contract for a period of 12 months by written notice to the contractor not later than 30 days before the contract expires. If the Government exercises this option, the extended contract shall be considered to include this clause, except, the total duration of the contract may not exceed 2 years (**May 31, 2025**) as a result of, and including, any extension(s) added under this clause. Further extension may be negotiated under the "Extension of Term of Contract" clause. See also "Economic Price Adjustment" clause for authorized pricing adjustment(s).

EXTENSION OF TERM OF CONTRACT

At the request of the Government, the term of any contract resulting from this solicitation may be extended for such period of time as may be mutually agreeable to the GPO and the contractor.

ECONOMIC PRICE ADJUSTMENT

The pricing under this contract shall be adjusted in accordance with this clause, provided that in no event will any pricing adjustment be made that would exceed the maximum permissible under any law in effect at the time of the adjustment.

There will be no adjustment for orders placed during the first period specified below. Pricing will thereafter be eligible for adjustment during the second and any succeeding performance period(s). For each performance period after the first, a percentage figure will be calculated as described below and that figure will be the economic price adjustment for that entire next period.

Pricing adjustments under this clause are not applicable to reimbursable postage or transportation costs, or to paper, if paper prices are subject to adjustment by separate clause elsewhere in this contract. *Note: Paper prices for this contract will be adjusted under the "Paper Price Adjustment" clause.*

For the purpose of this clause, performance under this contract will be divided into successive periods. The first period will extend from **Date of Award through May 31, 2024**, and the second and any succeeding period(s) will extend for 12 months from the end of the last preceding period, except that the length of the final period may vary. The first day of the second and any succeeding period(s) will be the effective date of the economic price adjustment for that period.

Pricing adjustments in accordance with this clause will be based on changes in the seasonally adjusted "Consumer Price Index For All Urban Consumers – Commodities Less Food" (Index) published monthly in the CPI Detailed Report by the U.S. Department of Labor, Bureau of Labor Statistics.

The economic price adjustment will be the percentage difference between Index averages as specified in this paragraph. An index called the variable index will be calculated by averaging the monthly Indexes from the 12-month interval ending three (3) months prior to the beginning of the period being considered for adjustment. This average is then compared to the average of the monthly Indexes for the 12-month interval ending **February 28, 2023**, called the base index. The percentage change (plus or minus) of the variable index from the base index will be the economic price adjustment for the period being considered for adjustment.

The Government will notify the contractor by contract modification specifying the percentage increase or decrease to be applied to invoices for orders placed during the period indicated. The contractor shall apply the percentage increase or decrease against the total price of the invoice less reimbursable postage or transportation costs and separately adjusted paper prices. Payment discounts shall be applied after the invoice price is adjusted.

If the Government exercises an option, the extended contract shall be considered to include this economic price adjustment clause.

PAPER PRICE ADJUSTMENT

Paper prices charged under this contract will be adjusted in accordance with “Table 9 – Producer Price Indexes and Percent Changes for Commodity Groupings and Individual Items” in Producer Price Indexes report, published by the Bureau of Labor Statistics (BLS), as follows:

1. BLS code 0913 for “All Paper” will apply to all paper required under this contract.
2. The applicable index figures for the month of **June 2023** will establish the base index.
3. There shall be no price adjustment for the first three months of the contract.
4. Price adjustments may be monthly thereafter, but only if the index varies by an amount (plus or minus) exceeding 5% by comparing the base index to the index for that month which is two months prior to the month being considered for adjustment.
5. Beginning with order placement in the fourth month, index variances will be calculated in accordance with the following formula:

$$\frac{X - \text{base index}}{\text{base index}} \times 100 = \text{___ \%}$$

where X = the index for that month which is two months prior to the month being considered for adjustment.

6. The contract adjustment amount, if any, will be the percentage calculated in 5 above less 5%.
7. Adjustments under this clause will be applied to the contractor’s bid price(s) for all line items under **Item III. Stock/Paper (a)** in the Schedule of Prices and will be effective on the first day of any month for which prices are to be adjusted.

The Contracting Officer will give written notice to the contractor of any adjustments to be applied to invoices for orders placed during months affected by this clause.

In no event, however, will any price adjustment be made which would exceed the maximum permissible under any law in effect at the time of the adjustment. The adjustment, if any, shall not be based upon the actual change in cost to the contractor, but shall be computed as provided above.

The contractor warrants that the paper prices set forth in this contract do not include any allowance for any contingency to cover anticipated increased costs of paper to the extent such increases are covered by this price adjustment clause.

PRE-AWARD SURVEY

In order to determine the responsibility of the prime contractor or any subcontractor, the Government reserves the right to conduct an on-site pre-award survey at the contractor's/subcontractor's facility or to require other evidence of technical, production, managerial, financial, and similar abilities to perform, prior to the award of a contract.

As part of the financial determination, the contractor in line for award may be required to provide one or more of the following financial documents:

1. Most recent profit and loss statement
2. Most recent balance sheet
3. Statement of cash flows
4. Current official bank statement
5. Current lines of credit (with amounts available)
6. Letter of commitment from paper supplier(s)
7. Letter of commitment from any subcontractor

The documents will be reviewed to validate that adequate financial resources are available to perform the contract requirements. Documents submitted will be kept confidential and used only for the determination of responsibility by the Government. Failure to provide the requested information in the time specified by the Government may result in the Contracting Officer not having adequate information to reach an affirmative determination of responsibility.

POST-AWARD CONFERENCE

Unless waived by the Government, the total requirements of the job as indicated in these specifications will be reviewed by Government representative(s) with the contractor's representative(s) at the contractor's plant or via telephone conference immediately after award.

ASSIGNMENT of JACKETS, PURCHASE and PRINT ORDERS

A GPO jacket number will be assigned and a purchase order issued to the contractor to cover work performed. The purchase order may be supplemented by an individual "Print Order" for each job placed with the contractor. The print order, when issued, will indicate the quantity to be produced and any other information pertinent to the particular order.

ORDERING

Items to be furnished under the contract shall be ordered by the issuance of print orders by the Government. Orders may be issued under the contract from **Date of Award through May 31, 2024** plus for such additional period(s) as the contract is extended. All print orders issued hereunder are subject to the terms and conditions of the contract. The contract shall control in the event of conflict with any print order. A print order shall be "issued" upon notification by the Government for purposes of the contract when it is electronically transmitted or otherwise physically furnished to the contractor in conformance with the schedule.

REQUIREMENTS

This is a requirements contract for the items and for the period specified herein. Shipment/delivery of items or performance of work shall be made only as authorized by orders issued in accordance with the clause entitled "Ordering." The quantities of items specified herein are estimates only, and are not purchased hereby. Except as may be otherwise provided in this contract, if the Government's requirements for the items set forth herein do not result in orders in the amounts or quantities described as "estimated", it shall not constitute the basis for an equitable price adjustment under this contract.

Except as otherwise provided in this contract, the Government shall order from the contractor(s) all the items set forth which are required to be purchased by the Government activity identified on page 1.

The Government shall not be required to purchase from the contractor(s), requirements in excess of the limit on total orders under this contract, if any.

Orders issued during the effective period of this contract and not completed within that time shall be completed by the contractor(s) within the time specified in the order, and the rights and obligations of the contractor(s) and the Government respecting those orders shall be governed by the terms of this contract to the same extent as if completed during the effective period of this contract.

If shipment/delivery of any quantity of an item covered by the contract is required by reason of urgency prior to the earliest date that shipment/delivery may be specified under this contract, and if the contractor(s) will not accept an order providing for the accelerated shipment/delivery, the Government may procure this requirement from another source.

The Government may issue orders which provide for shipment/delivery to or performance at multiple destinations.

Subject to any limitations elsewhere in this contract, the contractor shall furnish to the Government all items set forth herein which are called for by print orders issued in accordance with the "Ordering" clause of this contract.

ADDITIONAL EMAILED BID SUBMISSION PROVISIONS

The Government will not be responsible for any failure attributable to the transmission or receipt of the emailed bid including, but not limited to, the following:

1. Illegibility of bid.
2. Emails over 75 MB may not be received by GPO due to size limitations for receiving emails.
3. The bidder's email provider may have different size limitations for sending email; however, bidders are advised not to exceed GPO's stated limit.
4. When the email bid is received by GPO, it will remain unopened until the specified bid opening time. Government personnel will not validate receipt of the emailed bid prior to bid opening. GPO will use the prevailing Columbus, OH time and the exact time that the email is received by GPO's email server as the official time stamp for bid receipt at the specified location.

PAYMENT

Contractor's billing invoice must be itemized in accordance with the line items in the "Section 4. - Schedule of Prices." Failure to itemize invoice may result in delay of payment.

Submitting all invoices for payment via the GPO fax gateway (if no samples are required) utilizing the GPO barcode coversheet program application is the fastest method of getting paid. The information for using this method can be found at: <https://winapps.access.gpo.gov/fms/vouchers/barcode/instructions.html>.

Invoices may also be mailed to: U.S. Government Publishing Office; Office of Financial Management; Attn: Comptroller; Stop: FMCE; Washington, DC 20401.

For more information about the billing process refer to the General Information of the Office of Finance web page located at: <https://www.gpo.gov>.

At time of invoicing, the contractor shall submit a copy of the print order, contractor's invoice, and all mailing and/or delivery receipts via email to: infonortheast@gpo.gov.

SECTION 2. – SPECIFICATIONS

SCOPE

These specifications cover the production of envelopes requiring such operations as reproducible, printing, construction, packing, and distribution.

These envelopes are used in the processing of time sensitive taxpayer correspondence. Complete production and timely delivery, are critical to the mission of the IRS. Failure to receive envelopes on schedule can cause stock outages and excess cost and/or work stoppages or costly work-arounds at IRS processing centers.

TITLE

IRS E-178 Envelopes

NUMBER OF ORDERS/FREQUENCY OF ORDERS/QUANTITY

Based on anticipated usage, approximately 39 orders per year for various IRS offices. Approximately 10,000 to 20,000,000 envelopes per order. Minimum quantity is 10,000 envelopes.

No variation in quantities ordered on the individual print orders will be allowed.

The following estimated annual orders are anticipated:

Anticipated Annual Volume

Envelope Style	Orders between 10,000 and 100,000 Envelopes	Orders between 100,001 and 1,000,000 Envelopes	Orders between 1,000,001 and 20,000,000 Envelopes
E-178 (no indicia required) or E-178-2 (indicia required)	Anticipate 10 orders per year, usually E-178. Usually between 10,000 to 90,000 envelopes per order.	Anticipate 5 orders per year, usually E-178. Usually between 100,001 and 425,000 envelopes per order.	Anticipate 24 orders per year, usually E-178-2. Usually between 9,500,000 and 12,000,000 envelopes per order. Anticipate 1 order per month for each CPS site. Each order will have 4 to 6 deliveries, usually weekly. Most weeks will have 1 full truck load delivered. Usually 1 week per month will have 2 full truck loads delivered. Most orders will deliver to the Primary Delivery Location but an occasional order may have 1 or more deliveries to a Secondary Delivery Location. See "Distribution".

TRIM SIZE

4-3/8 x 9-3/4"

GOVERNMENT TO FURNISH

Print Orders and furnished material will be submitted via e-mail, files will be in PDF.

Print Orders (GPO Form 2511).

IRS Specification Sheets. See Exhibits 1 and 2. When furnished, the contractor is cautioned that mailing indicia may be used only for the purpose of producing printed envelopes under this contract.

IRS Form 6153 (Rev. 3-2006) Cat. No. 62724N Carton Shipping Label with marking specifications. See Exhibit 3.

Identification markings such as register marks, ring folios, rubber stamped jacket numbers, commercial identification marks of any kind, etc., form number, and revision date, carried on copy or film, must not print on finished product.

ENVELOPE SPECIFICATION SHEETS

The IRS Specification Sheets are representative of the requirements which will be ordered under this contract. Contractor will be expected to create necessary artwork from the IRS Envelope Specification Sheet furnished with the individual print order. Artwork shall be in accordance with USPS DMM regulations.

Each IRS Specification Sheet contains copy change areas for the inclusion of Permit Mail Indicum (Indicia required) which are allowable for that envelope. An N/A in the copy change or indicia required boxes means that no copy change is allowed in that area. When furnished, the contractor is cautioned that mailing indicia may be used only for the purpose of producing printed envelopes under this contract.

CONTRACTOR TO FURNISH

All materials and operations, other than those listed under "Government to Furnish", necessary to produce the products in accordance with these specifications.

REPRODUCIBLES

The contractor must make all reproducibles required. The contractor is responsible for determining what type reproducibles will be used but must maintain the quality level specified in the contract. No separate charges will be allowed for the various types of reproducibles that may be used.

PROOFS

PDF Proofs will be required only when indicated on the individual print order. It is anticipated that proofs will be required the first time an envelope style/version is ordered or when changes are made to an envelope style/version; however, proofs may be ordered at any time.

When proofs are ordered, the contractor to submit one "Press Quality" PDF soft proof (for content only) using the same Raster Image Processor (RIP) that will be used to produce the final printed product. PDF proof will be evaluated for text flow, image position, and color breaks. Proof will not be used for color match. Contractor must call the point of contact listed on the individual print order to confirm receipt.

When the individual print order does not require proofs, the contractor will be responsible for performing all necessary proofreading to ensure that the final product is in conformity with the Envelope Specification Sheet submitted and USPS postal regulations. Should there be a discrepancy between the Print Order and the Envelope Specification Sheet provided, and/or USPS postal regulations, the contractor must contact IRS to ensure the correct information is printed.

PRIOR-TO-PRODUCTION SAMPLES

Prior-to-Production Samples will be required only when indicated on the individual print order. Prior-to-Production Samples can be ordered at any time. It is anticipated that samples will be required the first time an envelope style is ordered or when changes are made to an envelope style.

The sample requirement for this contract is one set of 2,500 printed construction samples. Each sample shall be printed and constructed as specified and must be of the size, kind, and quality that the contractor will furnish.

Samples must be packed in accordance with "Packing" clause in Section 2, including the inner-packing.

Samples will be inspected and tested and must comply with the specifications as to construction, kind, and quality of materials.

APPROVAL FOR PRIOR TO PRODUCTION SAMPLES

Prior to the commencement of production of the contract production quantity, the contractor shall submit samples to the address indicated on the individual print order. Samples will be tested for conformance of material(s) and/or for usage on the specified equipment and/or for construction. The container and accompanying documentation shall be marked PREPRODUCTION SAMPLES and shall include the GPO jacket, purchase order, and program/print order numbers. The samples must be submitted in sufficient time to allow Government testing of the samples and production and shipment in accordance with the shipping schedule.

The Government will approve, conditionally approve, or disapprove the samples within 3 workdays of the receipt thereof. Approval or conditional approval shall not relieve the contractor from complying with the specifications and all other terms and conditions of the contract. A conditional approval shall state any further action required by the contractor. A notice of disapproval shall state the reasons therefor.

If the samples are disapproved by the Government, the Government, at its option, may require the contractor to submit additional samples for inspection and test, in the time and under the terms and conditions specified in the notice of rejection. Such additional samples shall be furnished, and necessary changes made, at no additional cost to the Government and with no extension in the shipping schedule. The Government will require the time specified above to inspect and test any additional samples required.

In the event the additional samples are disapproved by the Government, the contractor shall be deemed to have failed to make delivery within the meaning of the default clause in which event this contract shall be subject to termination for default, provided however, that the failure of the Government to terminate the contract for default in such event shall not relieve the contractor of the responsibility to deliver the contract quantities in accordance with the shipping schedule.

In the event the Government fails to approve, conditionally approve, or disapprove the samples within the time specified, the Contracting Officer shall automatically extend the shipping schedule in accordance with Contract Clause 12, "Notice of Compliance with Schedules," of GPO Contract Terms (GPO Publication 310.2, effective December 1, 1987 (Rev. 01-18)).

Manufacture of the final product prior to approval of the sample submitted is at the contractor's risk. Samples will not be returned to the contractor. All costs, including the costs of all samples shall be included in the contract price for the production quantity.

All samples shall be manufactured at the facilities in which the contract production quantities are to be manufactured.

STOCK/PAPER

The specifications of all paper furnished must be in accordance with those listed herein or listed for the corresponding JCP Code numbers in the "Government Paper Specification Standards No. 13" dated September 2019.

White Writing or Wove Envelopes, basis size 17 x 22", 24 lbs. per 500 sheets, equal to JCP Code V20.

PRINTING

Envelopes print face and back in black ink after construction as indicated on the IRS Envelope Specification Sheet furnished with each individual Print Order.

The constructed exterior face of the E-178 and E-178-2 envelopes print in black ink. The E-178-2 version requires a mailing permit (indicia). It is anticipated that orders for the E-178-2 will be for the IRS Processing Centers. The contractor is cautioned that mailing indicia may be used only for the purpose of producing printed envelopes under this contract.

The constructed exterior back of the E-178 and E-178-2 envelopes print in black ink with the envelope style and version, revision date, and the IRS catalog number.

All envelopes require a security tint printed on the constructed interior of the envelope in black ink.

Contractor may use stock design for security tint but must guarantee that the product will ensure complete opacity, and prevent show through of any material contained therein. No proprietary design or company logos allowed for design of security tint.

Printing shall be in accordance with the requirements for the type of envelope ordered. All printing shall comply with all applicable U.S. Postal Service regulations. Envelope printing must meet U.S. Postal Service Automation guidelines and requirements (refer to latest version of USPS Publication 25, Designing Business Letter Mail and the Domestic Mail Manual).

The envelopes must be manufactured and printed in a manner that shall permit the envelopes to accept printing, ink writing, and bar coding without feathering, blurring, smearing, or penetrating to the reverse side.

MARGINS

Follow margins on the Government furnished specification sheets.

CONSTRUCTION OF ENVELOPES

These specifications must be adhered to at all times to ensure accuracy of the system and to provide smooth flowing operations through the following equipment:

- Inserters:
 - Bell & Howell Enduro
 - Bell & Howell Forerunner
 - Neopost DS140
- Postage Meters:
 - Neopost IS-5000

The Envelope Specification Sheet furnished with each individual Print Order will provide specific construction requirements for seams, flaps, and windows and must be adhered to at all times. Envelopes shall be free from cuts, folds, tears, machine marks, foreign matter, dirt, ink smears, and adhesive stains.

SEAMS

Unless otherwise indicated on the IRS Envelope Specification Sheet, contractor's option for high cut diagonal or side seam construction. Envelopes with diagonal seams shall be sufficiently high cut so as to prevent the flap adhesive from contacting the envelope contents. The sealed seams shall not adhere to the inside of the envelope.

FLAPS

Flaps are open side and to be constructed as indicated on individual specification sheets. The flap must be a tapered "V" flap, minimum 2-3/16" and maximum 2-1/4" length. The sealing flap must exceed the throat by at least 3/4".

All sealing flap adhesive shall be a water-activated type of such a consistency to prevent premature sealing of the flap and curling of the envelope after drying.

The flap adhesive shall be uniformly applied and have a minimum thickness of 0.015mm (0.0006 inch). The flap shall be capable of being quickly and securely sealed using finger tips after moistening the adhesive. When opened 15 to 20 seconds after sealing, the flap shall pull fibers from the body of the envelope from not less than 75% of the adhesive area of the flap beyond the throat, up to a maximum width of one-inch gum strip from the edge of the flap.

Fully gummed flaps required, split gumming **IS NOT** permitted on any envelope. See individual IRS Envelope Specification Sheets for additional flap requirements.

WINDOWS

Windows for the E-178 and E-178-2 envelopes are multi-dimensional in shape, “bus” style, with rounded corners.

The window shall be covered on the inside with a clear polystyrene window material glued securely on all interior edges so as not to interfere with insertion of contents. The clear polystyrene window material shall be free of conditions which would prevent being machine read by USPS in accordance with the Domestic Mail Manual.

All window covering material **MUST BE TRANSPARENT**. Window covering must be a minimum of 1.5 mil thickness.

PACKING

Except for the 10 sample envelopes to be produced, the production quantity of envelopes shall be un-banded and sealing flap on open side shall be folded down. The shipping container shall be closed/sealed in accordance with GPO Contract Terms.

Envelopes must not be packed in oversized containers. All envelopes shall be securely packed in containers so as to prevent curling or warping due to excessive space. Spacers or fillers should only be added to the last shipping container to complete an odd order quantity (i.e. Blue Label and Yellow Label copies).

Inner-pack in units of 500 envelopes in close-fitting boxes with lids and then pack 5 boxes into shipping containers.

Shipping containers shall have a minimum bursting strength of 200 pounds per square inch or a minimum edge crush test (ECT) of 44 pounds per inch width.

LABELING AND MARKING

Reproduce IRS Form 6153 Carton Shipping Label from furnished PDF file, filling in appropriate information for Carton Numbers, Number of Cartons, and From (Contractor name and address) fields and attach to shipping containers. Contractor to ensure correct Jacket number, Print Order number and Program number are indicated on carton label. If the Requisition number does not match Print Order Requisition number notify wi.mp.envelope.program@irs.gov, infonortheast@gpo.gov, and lprice@gpo.gov.

The NDC Warehouse located in Bloomington, IL uses an automated warehousing system. All deliveries to the NDC Warehouse must be labeled with the IRS Form 6153 Carton Shipping Label provided with the individual Print Order. The barcode and its placement on the label are used to locate the carton in the warehouse. The receiving department at the NDC Warehouse will not accept shipments with cartons that are not labeled with the IRS Form 6153.

When Blue Label and Yellow Label sample cartons are included on a pallet, the pallet is to be labeled with a Sample Boxes Pallet Label. See Exhibit 4.

PALLETIZING

Palletizing is required if an order has at least 18 shipping containers going to one destination.

Double stacking of pallets is **NOT** permitted. Mixing of orders on pallets is **NOT** permitted.

Except for Size, pallets must conform with Federal Specifications NN-P 71C, and any amendments thereto, as follows: Type III, Group 2 or 3, four way (partial) flush pallet, size L 48” x W 40”. Full entry **MUST** be on the 40” width. See IRS Pallet Specifications, Exhibit 5.

Strict adherence to these dimensions is necessary to meet requirements of IRS storage facilities. Receipt of incorrect pallet construction may result in a charge assessed against the contractor for each incorrect pallet as described below. Shipping containers must be fastened securely to the pallet in a manner that will prevent lateral movement but will permit ready removal without damage to the containers.

Pallets shall be stacked with reverse layer pattern to insure acceptance and safe delivery by common carriers. Maximum height (including pallet) is 55". If this is not possible due to custom carton sizes for envelopes, other stacking patterns may be accepted with the application of corner protectors.

Palletized material shall be secured on pallet(s) by stretch-wrap plastic or plastic shrink-wrap. Single piece cardboard separator sheet between layers. Corner beads to be applied before wrapping. Pallets shall be suitably packed so as to ensure acceptance and safe delivery by common carrier.

Non-compliance with any of the palletizing requirements may be cause for the Government to reject the shipment at destination and return it to the contractor at the contractor's expense. After giving notice of deficiency and affording the contractor an opportunity and a reasonable time to correct, the Government, at its option, may re-palletize in accordance with the specifications and charge all costs to the contractor.

DEPARTMENTAL RANDOM COPIES (BLUE LABEL/YELLOW LABEL)

Each order will require two sets of departmental random copies with each partial delivery and with the complete and final delivery. One set must be labeled with the government furnished Blue Label (GPO Form 2678 – Certificate of Selection of Random Copies) and one set must be labeled with a contractor furnished Yellow Label (Blue Label information copied onto yellow paper).

All orders must be divided into equal sublots as indicated on the individual print order, usually 200 sublots. A random "Blue Label" copy and a random "Yellow Label" copy must be selected from each subplot (usually 200 Blue Label copies and 200 Yellow Label copies). Do not choose copies from the same general area in each subplot.

The contractor will be required to certify that all copies were selected as directed using GPO Form 917 – Certificate of Selection of Random Copies (located on www.gpo.gov). The GPO Form 917 shall be packaged with the "Blue Label" copies. The random copies constitute a part of the total quantity ordered, and no additional charge will be allowed.

These randomly selected copies must be packed separately and identified by a special label (GPO Form 2678 – Departmental Random Copies (Blue Label)) that must be printed on blue paper for "Blue Label Copies" and yellow paper for "Yellow Label Copies" and affixed to each affected container. The containers and their contents shall be recorded separately on all shipping documents and sent in accordance with the "Distribution" clause below.

A copy of the print order/specification and a signed Certificate of Selection of Random Copies must be included with the "Blue Label" copies. These forms can be downloaded from www.gpo.gov. A copy of the print order/specification must be included with the "Yellow Label" copies.

DISTRIBUTION

Deliver f.o.b. destination to the address indicated on the individual print order.

Due to inventory constraints, the CPS Processing Centers may have one or more deliveries diverted to a location with available space, see "Secondary Delivery Location" below.

CPS Processing Centers

IRS Facility	Primary Delivery Location	Secondary Delivery Locations
CPS-West Processing Center	Ogden, Utah	Detroit, Michigan Bloomington, Illinois Kearneysville, West Virginia
CPS-East Processing Center	Detroit, Michigan	Ogden, Utah Bloomington, Illinois Kearneysville, West Virginia

NDC Processing Center and Warehouse, IRS Campuses, and NOP Office Delivery Locations

IRS Facility	Delivery Location
NDC Processing Center, also serves as warehouse for the following campuses: <ul style="list-style-type: none"> • Fresno Campus • Cincinnati/Covington Campus • Memphis Campus • Atlanta Campus • Philadelphia Campus • Brookhaven Campus • Andover Campus 	Bloomington, Illinois
Ogden Campus	Ogden, Utah
Austin Campus	Austin, Texas
Kansas City Campus	Kansas City, Missouri
N.O.P. Publishing Office	Cincinnati, Ohio

Due to high security at all IRS Facilities, detailed information may be required from delivery carriers to confirm the identity of the driver and equipment used for delivery. Additionally, 24 to 48-hour advance **e-mail notification** of intended deliveries shall be required to schedule availability of loading docks.

Deliveries to Bloomington, Illinois and Kearneysville, West Virginia will require the trucking company to **phone ahead and schedule delivery**.

In addition to a phone call to schedule delivery, the deliveries to Kearneysville, West Virginia location will require the contractor to submit the following information to the Government no less than 72 hours in advance: Driver(s) Name(s), Trucking Company Name, Date of Delivery, Purchase Order Number, and Number of Pallets/Skids.

At same time as bulk delivery is made, 10 printed samples of each order must be banded together and a copy of the print order wrapped around or attached to the front of the envelopes. When packaging multiple sample packages, the individually banded sample packages are to be consolidated into a large carton and delivered to:

IRS
ATTN: Carl Slater
M/S 8100
1160 West 1200 South
Ogden UT 84404

On the same day that the product ships/delivers, the contractor must notify wi.mp.envelope.program@irs.gov, infortheast@gpo.gov, and the individual identified on the individual print order of the distribution. The subject line of the message shall be “Distribution Notice for Program 2554-S, Print Order (enter print order number)”. The e-mail must provide all applicable tracking numbers, shipping method, and program title. Contractor must be able to provide copies of all delivery, mailing, and shipping receipts (as applicable) upon agency request.

Notifications to delivery points and scheduling of deliveries is an integral part of the distribution requirements and will be discussed at the post-award conference.

SCHEDULE

Adherence to this schedule must be maintained. Contractor must not start production of any job prior to receipt of the individual print order (GPO Form 2511) and specification sheet via e-mail. The first workday of the schedule begins upon receipt of print order and specification sheet.

Orders will be placed/confirmed as follows:

1. The agency will notify the contractor, by e-mail or telephone, when an order(s) is/are ready to be placed.
2. The agency will then e-mail the print order(s) and specification sheet(s) and will indicate the agency individual(s) to be contacted upon receipt of the e-mail.
3. The contractor must notify the individual(s) as indicated within 60 minutes after notification to confirm receipt of print order(s) and specification sheet(s).

The ship/deliver date indicated on the print order is the date products must be received at each destination.

Although orders may be placed at any time during the contract term, it is anticipated that most orders will be placed in the first week of each month.

The individual Print Order will indicate if proofs and/or prior-to-production samples are required.

It is anticipated that proofs will be ordered with the first order of an envelope style and version. Proofs are due 2 workdays after receipt of Print Order and are to be emailed to wi.mp.envelope.program@irs.gov and lprice@gpo.gov. Proofs will be held for 3 workdays.

It is anticipated that prior-to-production samples will be required with the first order of an envelope style but not with each version. Samples are due 2 workdays after proof approval is received and samples will be held for 3 workdays. Samples are to be sent to the Ogden, UT address indicated on the individual Print Order.

The ship/deliver date indicated on the print order is the date products must be received at each destination.

Upon completion of each order, the contractor is to notify IRS and GPO Northeast Region of the date of delivery. See, "Delivery/Shipping Status Information".

Unscheduled material such as shipping documents, receipts or instructions, delivery lists, labels, etc., will be furnished with each order or shortly thereafter. In the event such information is not received in due time, the contractor will not be relieved of any responsibility in meeting the shipping schedule because of failure to request such information.

PRODUCTION SCHEDULE

Complete production and delivery (or initial partial delivery) will be required within 25 and 45 workdays after receipt of print order. Subsequent partial deliveries, when required, will occur between 2 and 30 workdays after the delivery of the previous partial delivery. Most CPS-West and CPS-East deliveries will require partial deliveries on a weekly basis.

Any envelope delivering to any location may require partial deliveries consisting of 75,000 to 4,500,000 envelopes.

It is anticipated that partial deliveries to CPS-West and CPS-East will be in quantities constituting one or two full truckloads. Orders delivering to NDC may require partial deliveries in quantities constituting less than one full truckload or constituting one full truckload.

Individual print order will indicate the quantity of and the due dates of the complete delivery and, if applicable, the due dates of each partial delivery.

DELIVERY/SHIPPING STATUS INFORMATION

Contractor to create an Order Tracking Report in Excel or similar spreadsheet software. See Exhibit 6, for a sample report layout with required column headers. The contractor is to maintain the report for the full term of the contract, including any optional terms exercised under the "Option to Extend Term of Contract" clause.

The report will be used for tracking purposes and for compliance reporting purposes. The report shall include the date of delivery (or shipment if applicable) for proofs and prior-to-production samples, and delivery schedules in accordance with the contract requirements.

The report shall be updated with each ordering period. All reports are to be e-mailed to wi.mp.envelope.proram@irs.gov and infonortheast@gpo.gov. Frequency of the reports and naming conventions will be discussed at the Post-Award Conference.

RECEIPT FOR DELIVERY

Contractor must furnish own receipts for delivery. These receipts must include the GPO jacket, program, and print order numbers; total quantity delivered, number of cartons, and quantity per carton; date delivery made; and signature of the Government agent accepting delivery. The original copy of this receipt must accompany the contractor's voucher for payment.

SECTION 3. – DETERMINATION OF AWARD

The Government will determine the lowest bid by applying the prices offered in the “Schedule of Prices” to the following units of production which are the estimated requirements to produce one year’s orders under this contract. These units do not constitute, nor are they to be construed as, a guarantee of the volume of work which may be ordered for a like period of time.

The following item designations correspond to those listed in the “Schedule of Prices”.

I.	(a)	2	
	(b)	2	
II.		(1)	(2)
	(a)	10	550
	(b)	5	1,333
	(c)	24	253,500
III.	(a)	255,383	
IV.	(a)	123,681	
	(b)	10	
	(c)	22	
	(d)	4,552	
	(e)	123,117	
	(f)	101	
	(g)	3,900	

SECTION 4. – SCHEDULE OF PRICES

Bids offered are f.o.b. destination to locations in Utah, Texas, Missouri, Illinois, Michigan, Ohio, and West Virginia.

Prices must be submitted for the entire term of the contract and bids qualified for a lesser period will not be considered.

Prices must include the cost of all required materials and operations for each item listed in accordance with these specifications.

Bidder must make an entry in each of the spaces provided. Bids submitted with any obliteration, revision, or alteration of the order and manner of submitting bids, may be declared nonresponsive.

An entry of NC (No Charge) shall be entered if bidder intends to furnish individual items at no charge to the Government.

Bids submitted with NB (No Bid), NA (Not Applicable), or blank spaces for an item may be declared nonresponsive.

The Contracting Officer reserves the right to reject any offer that contains prices for individual items of production (whether or not such items are included in the Determination of Award) that are inconsistent or unrealistic in regard to other prices in the same offer or to GPO prices for the same operation if such action would be in the best interest of the Government.

All vouchers submitted to the GPO shall be based on the most economical method of production.

Fractional parts of 1,000 will be prorated at the 1,000 rate.

I. PROOFS AND PRIOR-TO-PRODUCTION SAMPLES: Prices must be all-inclusive and must include the cost of all required materials and operations necessary for the complete production of Proofs and Prior-To-Production Samples of the product listed in accordance with these specifications.

- (a) PDF Proofs..... per PDF proof..... \$ _____
- (b) Prior-To-Production Samples (2,500 samples per set) per set..... \$ _____

II. PRINTING/CONSTRUCTION: Prices must be all-inclusive and must include the cost of all required materials and operations necessary for the complete production of the product listed in accordance with these specifications except for Items I. Proofs and Prior-to-Production Samples, III. Stock/Paper, and IV. Packing and Shipping Charges.

	Makeready and/or Setup (1)	Running per 1,000 Envelopes (2)
(a) Quantities of 10,000 to 100,000 envelopes..... per order.....	\$ _____	\$ _____
(b) Quantities of 100,001 to 1,000,000 envelopes..... per order.....	\$ _____	\$ _____
(c) Quantities of 1,000,001 to 20,000,000 envelopes..... per order.....	\$ _____	\$ _____

(Initials)

EMAIL THIS PAGE TO BIDSNORTHEAST@GPO.GOV

SCHEDULE OF PRICES

III. STOCK/PAPER: Payment for all stock/paper supplied by the contractor under the terms of these specifications, as ordered on the individual print orders, will be based on the finished size of the envelopes. The cost of any paper required for makeready or running spoilage must be included in the prices offered.

(a) E-178 and E-178-2 Envelopes per 1,000 envelopes \$ _____

IV. PACKING AND SHIPPING CHARGES: The following charges cover the cost of packing, sealing, and shipping to destinations within each of the locations listed below. Reimbursement for transportation costs for all shipments will be made in accordance with the contractor’s offered shipping charges. Bidder must offer a cost per 1,000 envelopes for location as listed below. Failure to offer shipping charges to any of the locations will eliminate bidder from consideration for award.

(a) Deliver to Ogden, Utah per 1,000 envelopes \$ _____

(b) Deliver to Austin, Texas per 1,000 envelopes \$ _____

(c) Deliver to Kansas City, Missouri per 1,000 envelopes \$ _____

(d) Deliver to Bloomington, Illinois per 1,000 envelopes \$ _____

(e) Deliver to Detroit, Michigan per 1,000 envelopes \$ _____

(f) Deliver to Cincinnati, Ohio per 1,000 envelopes \$ _____

(g) Deliver to Kearneysville, West Virginia per 1,000 envelopes \$ _____

(Initials)

EMAIL THIS PAGE TO BIDS_NORTHEAST@GPO.GOV

SCHEDULE OF PRICES

SHIPMENT(S): Shipments will be made from: City _____, State _____

The city(ies) indicated above will be used for evaluation of transportation charges when transportation charges are specified to be a factor in determination of award. If no shipping point is indicated above, it will be deemed that the bidder has selected the city and state shown below in the address block, and the bid will be evaluated and the contract awarded on that basis. If shipment is not made from evaluation point, the contractor will be responsible for any additional shipping costs incurred.

DISCOUNTS: Discounts are offered for payment as follows: _____ Percent, _____ calendar days. See Article 12 "Discounts" of Solicitations Provisions in GPO Contract Terms (Publication 310.2).

AMENDMENT(S): Bidder hereby acknowledges amendment(s) number(ed) _____

BID ACCEPTANCE PERIOD: In compliance with the above, the undersigned agree, if this bid is accepted within _____ calendar days (60 calendar days unless a different period is inserted by the bidder) from the date for receipt of bids, to furnish the specified items at the price set opposite each item, delivered at the designated point(s), in exact accordance with specifications.

NOTE: Failure to provide a 60-day bid acceptance period may result in expiration of the bid prior to award.

BIDDER'S NAME AND SIGNATURE: Unless specific written exception is taken, the bidder, by signing and submitting a bid, agrees with and accepts responsibility for all certifications and representations as required by the solicitation and GPO Contract Terms – Publication 310.2. When responding by email, fill out and return one copy of all pages in "SECTION 4. – SCHEDULE OF PRICES," including initialing/signing where indicated. Valid electronic signatures will be accepted in accordance with the Uniform Electronic Transactions Act, §2. Electronic signatures must be verifiable of the person authorized by the company to sign bids.

Failure to sign the signature block below may result in the bid being declared non-responsive.

Bidder _____
(Contractor Name) (GPO Contractor's Code)

(Street Address)

(City – State – Zip Code)

By _____
(Printed Name, Signature, and Title of Person Authorized to Sign this Bid) (Date)

(Person to be Contacted) (Telephone Number) (Email)

THIS SECTION FOR GPO USE ONLY

Contracting Officer Review _____ Date _____ Certifier _____ Date _____

EMAIL THIS PAGE TO BIDSNORTHEAST@GPO.GOV

EXHIBITS

EXHIBIT 1: E-178 ENVELOPE SPECIFICATION SHEET

Envelope 178 (Rev. 9-2003) Envelope Specification Sheet			
This sheet is for envelope specifications and composition. Do not use as camera copy. Envelope must conform to the USPS requirements.			
Product ID Envelope 178 (Rev. 9-2003)	Copy change area A (return address) N/A	Copy change area B (mailing address) N/A	Indicia required N/A
Print order number	Office ID	Version	N/A
Envelope Specifications			
Construction Printed open side, high cut, diagonal or side seam, with tapered 2-3/16" V flap (not to exceed 2-1/4"), flap gummed and folded down. This envelope requires black opaquing design printed inside. Material covering window is 1.5 mil clear polystyrene.			
Text Specifications Font is Helvetica (or equal). Official Business (two line statement) is 9 point. Back printing is 6 point.			
Size 4-3/8" x 9-3/4" 111 mm x (248 mm)	Stock White Writing or White	Window Multi-dimensional (see diagram) 1.5 mil thickness	Ink Black
Additional comments			
Back Printing Position bottom & right margins appropriately in lower right corner.			
Envelope 178 (Rev. 9-2003) Catalog Number 6248D			
Form 12847-R (Rev. 2-2020)		Catalog Number 30851N	
Department of the Treasury - Internal Revenue Service publish no. irs.gov			

EXHIBIT 2: E-178-2 ENVELOPE SPECIFICATION SHEET

Envelope 178-2 (Rev. 9-2003) (CPS East & West G48PR1C Version) Envelope Specification Sheet

This sheet is for envelope specifications and composition. Do not use as camera copy. Envelope must conform to the USPS requirements.

Product ID Envelope 178	Copy change area A (return address) N/A	Copy change area B (mailing address) N/A	Indicia required G-48 Presorted 1st class	Print order number	Office ID N/A
Revision date (Rev. 9-2003)				Version G48PR1C	

Envelope Specifications

Construction

Printed open side, high cut, diagonal or side seam, with tapered 2-3/16" V flap (not to exceed 2-1/4"), flap gummed and folded down.

This envelope requires black opaquing design printed inside.

Material covering window is 1.5 mil clear polystyrene.

Text Specifications

Font is Helvetica (or equal).

Official Business (two line statement) is 9 point.

Back printing is 6 point.

Size 4-3/8" x 9-3/4" 111 mm x (248 mm)	Stock White Writing or 111 mm x 248 mm
Ink Black	Window Multi-dimensional (see diagram) 1.5 mil thickness

Additional comments

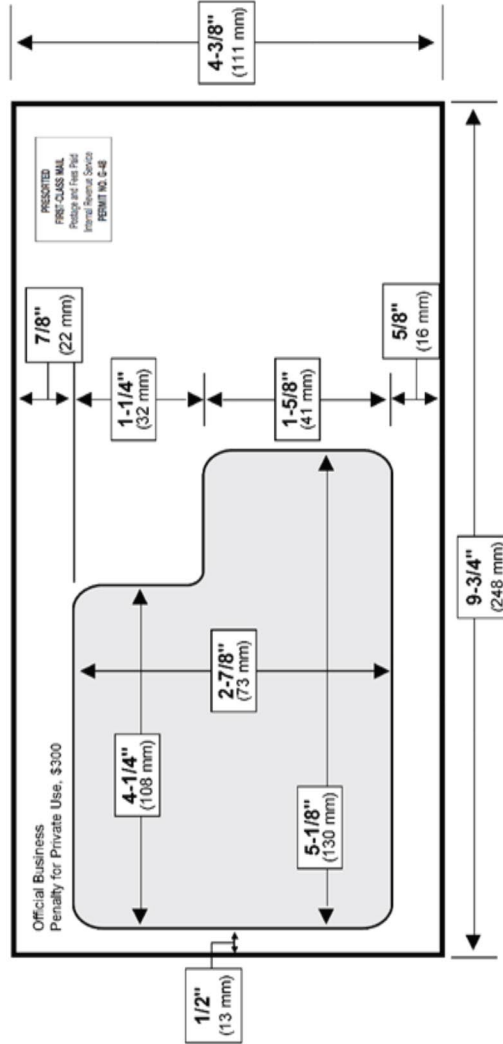

Back Printing

Position bottom & right margins appropriately in lower right corner.

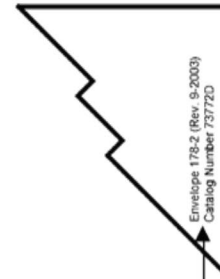

EXHIBIT 3: CARTON SHIPPING LABEL, FORM 6153 (REV. 3-2006)

Read Prior to Producing or Labeling Cartons

Labels **MUST** be generated from the PDF file provided. Handwritten updates are not allowed on any label. If these instructions are not followed, the Contractor will be held responsible for all re-labeling charges.

Section I – Prior to Producing Label

- 1) **Contact the IRS for a new carton label** if any of the following fields are blank when the label is received:
(a) Catalog number, (b) Revision, (c) Requisition number, (d) Product number, or (e) Product title.
- 2) **Fields for Contractor to Update Electronically:** (a) Carton # of # (see number Section I, 3 below); (b) From address; (c) To address (see exception under Section II, 2, Cartons via Small Package Carrier (SPC) below); and (d) Carton quantity (if carton quantity is blank, it must be updated with the correct packing quantity).
- 3) **Automated Carton # of # fields:** To print the correct number of labels for each address with sequential carton numbers, input the total number of cartons in second # field and press "Print Labels" button. **Warning: Once the print button is pressed, printing cannot be canceled. Be sure all information is correct prior to printing.**
- 4) **Printing:** Labels must be produced same-size in black ink on white paper.
- 5) **Proof:** An electronic proof of the label may be required if indicated on the contract or print order.

Section II – Labeling for Shipment

- 1) **Cartons:** All cartons must have IRS shipping label affixed to one end of the carton only (never on top, long-side, or bottom).
- 2) **Cartons via Small Package Carrier (SPC):** Affix SPC label to top of carton on edge nearest to IRS label. If shipping via SPC to the IRS National Distribution Center, leave the "To (Consignee)" address field blank.
- 3) **Small SPC packages/boxes/envelopes via SPC:** Affix IRS label to front of package and SPC label to the back. This includes advance distributions and IRS samples.

cut here cut here

Phaser 7300DX - Room 6231 **Print Labels** **SAVE AS** **RESET**

Carton Shipping Label

Department of the Treasury Internal Revenue Service		Publishing analyst Brian Anderson	Phone number 859-488-3701	Carton #	of #
GPO Jacket number 640-468		Print order number	Program number		
From (Contractor name and address)			To (Consignee) Internal Revenue Service National Distribution Center 1201 N. Mitsubishi Motorway Bloomington, IL 61705		
Catalog number 64288W	Revision (YYYY-MM-DD) 2000-03-00	 *64288W2000-03-00*			
Product number (Form, Document, Publication, etc) E-182 W		Product title CIDS Mailer Envelope			
Carton quantity 500	Requisition number (YY-nnnn) 19-01687	 *50019-01687*			

Form **6153** (Rev. 3-2006) Catalog Number 62724N Department of Treasury - Internal Revenue Service
Phaser 7300DX - Room 6231 **Print Labels** **SAVE AS** **RESET**

EXHIBIT 4: SAMPLE BOXES PALLET LABEL

BLUE LABEL

YELLOW LABEL

SAMPLES BOXES ARE ON THIS
PALLET

Print Order #'s:

EXHIBIT 5: IRS PALLET SPECIFICATIONS

IRS Pallet Specifications

All shipments delivered to the National Distribution Center (NDC), must conform to the specifications outlined in this document. To ensure shipments are 100% compliant and received by the NDC, please reference Publication 4803 and any relating information outlined in the work contract specifications. Non-conformance to the specifications of this document, the standards described in Publication 4803 and or specific instructions outlined in the work contract specifications, may result in corrections at the vendor's expense.

Pallet Measurements

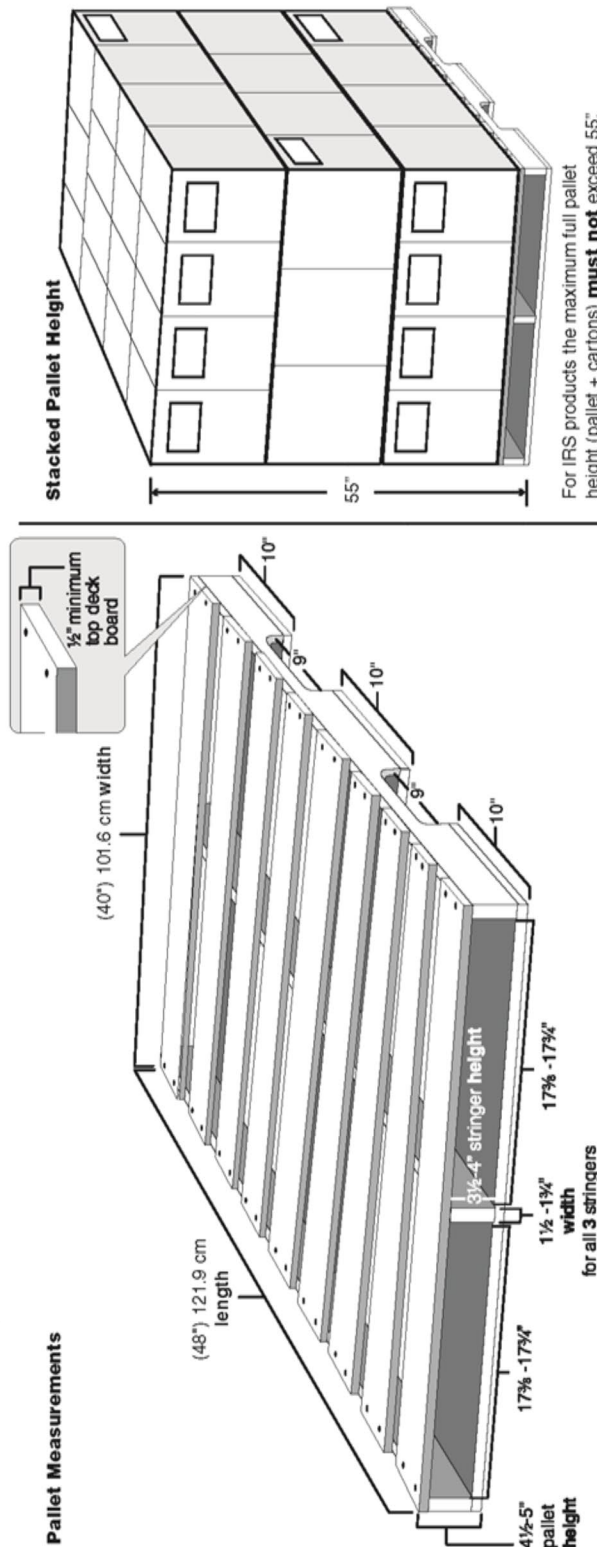

For IRS products the maximum full pallet height (pallet + cartons) **must not** exceed 55".

15 tier stacking method

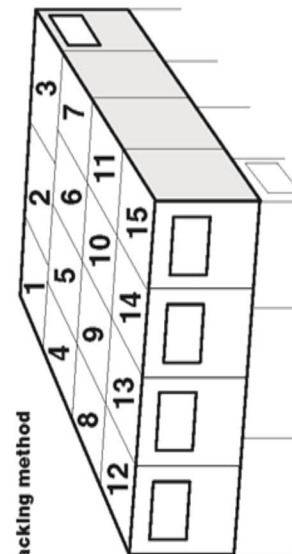

Shipments requiring palletization of cartons for non-Standard (i.e. products that are not and can not be folded down to an 8.5' x 11' size without destroying the functionality or integrity of the product) IRS products should be stacked using this 15 tier method.

9 tier stacking method

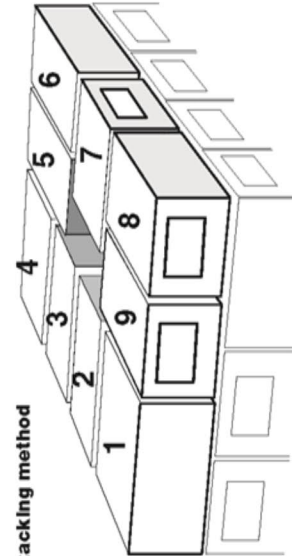

Products that are 8.5' x 11' or can be folded to those dimensions are considered standard IRS products and should be stacked using this 9 tier method.

EXHIBIT 6: ORDER TRACKING REPORT

FY 17	QTR: 3	Program 2554-S -- Quarterly Order Tracking Report										As of: 7/1/2017		
Print Order No.	IRS Req. No.	Vendor Job No.	Date Rec'd	Envelope No.	Indicia	Quantity Ordered	Due Date	Quantity Shipped	Actual Ship	Expected Delivery	Actual Delivery	Ship to Location	Trucking Company	PRO Number
83817	2017-01484	91748	5/10	E-142	G481C	1,950,400	6/22	1,950,400	6/15	6/22	6/22	Ogden, UT	YRC	1234567 P
83818	2017-01485	91754	5/10	E-178	G481C	1,950,400	6/23	1,950,400	6/16	6/23	6/23	Ogden, UT	YRC	1234568 P
83818	2017-01485	91755	5/10	E-178	G481C	1,950,400	6/30	1,950,400	6/23	6/30	6/29	Ogden, UT	ODFL	PRO 12345
83818	2017-01485	91756	5/10	E-178	G481C	1,950,400	7/7	1,950,400	6/30	7/7		Ogden, UT	YRC	1234572 P
83818	2017-01485	91757	5/10	E-178	G481C	3,900,800	7/14					Ogden, UT		
83819	2017-01486	91762	5/11	E-205	None	1,950,400	6/22	1,950,400	6/12	6/19	6/16	Ogden, UT	ODFL	PRO 12346
83819	2017-01486	91763	5/11	E-205	None	1,950,400	7/13					Ogden, UT		
85506	2017-1592	91765	5/9	E-130	None	100,400	6/21	100,400	6/12	6/19	6/20	Austin, TX	SAIA	PR 456789