

A_c = casualty area (from table C-3)
 A_k = populated area

N_k = population in A_k

TABLE C-3—EFFECTIVE CASUALTY AREA (MILES²) AS A FUNCTION OF IIP RANGE (NM)

Instantaneous impact point range (nautical miles)	Orbital launch vehicles				Suborbital launch vehicles
	Small	Medium	Medium large	Large	Guided
0–49	3.14 x 10 ⁻²	1.28 x 10 ⁻¹	4.71 x 10 ⁻²	8.59 x 10 ⁻²	4.3 x 10 ⁻¹
50–1749	2.47 x 10 ⁻²	2.98 x 10 ⁻²	9.82 x 10 ⁻³	2.45 x 10 ⁻²	1.3 x 10 ⁻¹
1750–5000	3.01 x 10 ⁻⁴	5.52 x 10 ⁻³	7.82 x 10 ⁻³	1.14 x 10 ⁻²	3.59 x 10 ⁻⁶

(8) An applicant shall estimate the total corridor risk using the following summation of risk:

$$E_c(\text{Corridor}) = \left(\sum_{k=1}^n E_{c_k} \right) \quad (\text{Equation C10})$$

(9) Alternative casualty expectancy (E_c) analyses. An applicant may employ specified variations to the analysis defined by subparagraphs (c)(1)–(8). Those variations are identified in subparagraphs (9)(i) through (vi) of this paragraph. Subparagraphs (i) through (iv) permit an applicant to make conservative assumptions that would lead to an overestimation of the corridor E_c compared with the analysis defined by subparagraphs (c)(1)–(8). In subparagraphs (v) and (vi), an applicant that would otherwise fail the analysis prescribed by subparagraphs (c)(1)–(8) may avoid (c)(1)–(8)'s overestimation of the probability of impact in each populated area. An applicant employing a variation shall identify the variation used, show and discuss the specific assumptions made to modify the analysis defined by subparagraphs (c)(1)–(8), and demonstrate how each assumption leads to overestimation of the corridor E_c compared with the analysis defined by subparagraphs (c)(1)–(8).

(i) Assume that P_x and P_y have a value of 1.0 for all populated areas.

(ii) Combine populated areas into one or more larger populated areas, and use a population density for the combined area or areas equal to the most densely populated area.

(iii) For any given populated area, assume P_y has a value of one.

(iv) For any given P_x sector (an area spanning the width of a flight corridor and bounded by two time points on the trajectory IIP ground trace) assume P_y has a value of one and use a population density for the sector equal to the most densely populated area.

(v) For a given populated area, divide the populated area into smaller rectangles, de-

termine P_i for each individual rectangle, and sum the individual impact probabilities to determine P_i for the entire populated area.

(vi) For a given populated area, use the ratio of the populated area to the area of the P_i rectangle from the subparagraph (c)(1)–(8) analysis.

(d) Evaluation of Results

(1) If the estimated expected casualty does not exceed 30x10⁻⁶, the FAA will approve the launch site location.

(2) If the estimated expected casualty exceeds 30x10⁻⁶, then an applicant may either modify its proposal, or, if the flight corridor used was generated by the appendix A method, use the appendix B method to narrow the flight corridor and then perform another appendix C risk analysis.

[Docket No. FAA-1999-5833, 65 FR 62861, Oct. 19, 2000, as amended by Amdt. 420-2, 71 FR 51972, Aug. 31, 2006]

APPENDIX D TO PART 420—IMPACT DISPERSION AREAS AND CASUALTY EXPECTANCY ESTIMATE FOR AN UNGUIDED SUBORBITAL LAUNCH VEHICLE

(a) Introduction

(1) This appendix provides a method for determining the acceptability of the location of a launch point from which an unguided suborbital launch vehicle would be launched. The appendix describes how to define an overflight exclusion zone and impact dispersion areas, and how to evaluate whether the public risk presented by the launch of an

unguided suborbital launch vehicle remains at acceptable levels.

(2) An applicant shall base its analysis on an unguided suborbital launch vehicle whose final launch vehicle stage apogee represents the intended use of the launch point.

(3) An applicant shall use the apogee of each stage of an existing unguided suborbital launch vehicle with a final launch vehicle stage apogee equal to the one proposed, and calculate each impact range and dispersion area using the equations provided.

(4) This appendix also provides a method for performing an impact risk analysis that estimates the expected casualty (E_c) within each impact dispersion area. This appendix provides an applicant options to simplify the method where population at risk is minimal.

(5) If the estimated E_c is less than or equal to 30×10^{-6} , the FAA will approve the launch point for unguided suborbital launch vehicles. If the estimated E_c exceeds 30×10^{-6} , the proposed launch point will fail the launch site location review.

(b) Data Requirements

(1) An applicant shall employ the apogee of each stage of an existing unguided suborbital launch vehicle whose final stage apogee represents the maximum altitude to be reached by unguided suborbital launch vehicles launched from the launch point. The apogee shall be obtained from one or more actual flights of an unguided suborbital launch vehicle launched at an 84 degree elevation.

(2) An applicant shall satisfy the map and plotting data requirements of appendix A, paragraph (b).

(3) Population data. An applicant shall use total population (N) and the total landmass area within a populated area (A) for all populated areas within an impact dispersion area. Population data up to and including 100 nm from the launch point are required at the U.S. census block group level. Population data downrange from 100 nm are required at no greater than $1^\circ \times 1^\circ$ latitude/longitude grid coordinates.

(c) Overflight Exclusion Zone and Impact Dispersion Areas

(1) An applicant shall choose a flight azimuth from a launch point.

(2) An applicant shall define an overflight exclusion zone as a circle with a radius of 1600 feet centered on the launch point.

(3) An applicant shall define an impact dispersion area for each stage of the suborbital

launch vehicle chosen in accordance with subparagraph (b)(1) in accordance with the following:

(i) An applicant shall calculate the impact range for the final launch vehicle stage (D_n). An applicant shall set D_n equal to the last stage apogee altitude (H_n) multiplied by an impact range factor [IP(H_n)] in accordance with the following:

$$D_n = H_n \cdot \text{IP}(H_n) \quad (\text{Equation D1})$$

where:

IP(H_n) = 0.4 for an apogee less than 100 km, and

IP(H_n) = 0.7 for an apogee of 100 km or greater.

(ii) An applicant shall calculate the impact range for each intermediate stage (D_i), where $i \in \{1, 2, 3, \dots, (n-1)\}$, and where n is the total number of launch vehicle stages. Using the apogee altitude (H_i) of each intermediate stage, an applicant shall use equation D1 to compute the impact range of each stage by substituting H_i for H_n . An applicant shall use the impact range factors provided by equation D1.

(iii) An applicant shall calculate the impact dispersion radius for the final launch vehicle stage (R_n). An applicant shall set R_n equal to the last stage apogee altitude (H_n) multiplied by an impact dispersion factor [DISP(H_n)] in accordance with the following:

$$R_n = H_n \cdot \text{DISP}(H_n) \quad (\text{Equation D2})$$

where:

DISP(H_n) = 0.4 for an apogee less than 100 km, and

DISP(H_n) = 0.7 for an apogee of 100 km or greater.

(iv) An applicant shall calculate the impact dispersion radius for each intermediate stage (R_i), where $i \in \{1, 2, 3, \dots, (n-1)\}$ and where n is the total number of launch vehicle stages. Using the apogee altitude (H_i) of each intermediate stage, an applicant shall use equation D2 to compute an impact dispersion radius of each stage by substituting H_i for H_n . An applicant shall use the dispersion factors provided by equation D2.

(4) An applicant shall display an overflight exclusion zone, each intermediate and final stage impact point (D_i through D_n), and each impact dispersion area for the intermediate and final launch vehicle stages on maps in accordance with paragraph (b)(2).

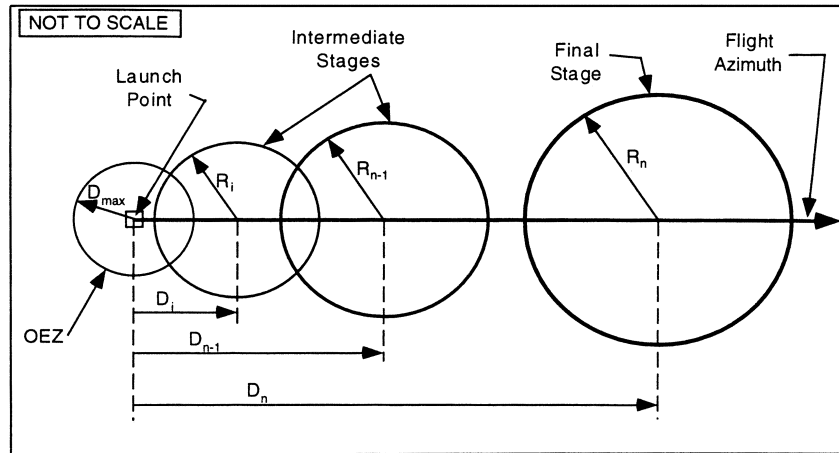

Figure D-1
Unguided Suborbital Launch Vehicle Overflight Exclusion Zone and Impact Dispersion Areas

(d) Evaluate the Overflight Exclusion Zone and Impact Dispersion Areas

(1) An applicant shall evaluate the overflight exclusion zone and each impact dispersion area for the presence of any populated areas. If an applicant determines that no populated area is located within the overflight exclusion zone or any impact dispersion area, then no additional steps are necessary.

(2) If a populated area is located in an overflight exclusion zone, an applicant may modify its proposal or demonstrate that there are times when no people are present or that the applicant has an agreement in place to evacuate the public from the overflight exclusion zone during a launch.

(3) If a populated area is located within any impact dispersion area, an applicant may modify its proposal and define a new overflight exclusion zone and new impact

dispersion areas, or perform an impact risk analysis in accordance with paragraph (e).

(e) Impact Risk Analysis

(1) An applicant shall estimate the expected average number of casualties, E_c , within the impact dispersion areas according to the following method:

(i) An applicant shall calculate the E_c by summing the impact risk for the impact dispersion areas of the final launch vehicle stage and all intermediate stages. An applicant shall estimate E_c for the impact dispersion area of each stage by using equations D3 through D7 for each of the populated areas located within the impact dispersion areas.

(ii) An applicant shall estimate the probability of impacting inside the X and Y sectors of each populated area within each impact dispersion area using equations D3 and D4:

$$P_x = \frac{\left(\frac{x_2}{\sigma_x} - \frac{x_1}{\sigma_x} \right)}{6\sqrt{2\pi}} \cdot \left(\exp \left(\frac{-\left(\frac{x_1}{\sigma_x} \right)^2}{2} \right) + 4 \cdot \exp \left[\frac{-\left(\frac{x_1 + x_2}{2\sigma_x} \right)^2}{2} \right] + \exp \left(\frac{-\left(\frac{x_2}{\sigma_x} \right)^2}{2} \right) \right) \quad \text{(Equation D3)}$$

where:

x_1, x_2 = closest and farthest downrange distance to populated area (see figure D-2)

σ_x = one-third of the impact dispersion radius (see figure D-2) exp = exponential function (e^x)

$$P_y = \frac{\left(\frac{|y_2|}{\sigma_y} - \frac{|y_1|}{\sigma_y}\right)}{6\sqrt{2\pi}} \cdot \left(\exp\left(\frac{-(y_1/\sigma_y)^2}{2}\right) + 4 \cdot \exp\left(\frac{-(y_1+y_2)^2}{2\sigma_y^2}\right) + \exp\left(\frac{-(y_2/\sigma_y)^2}{2}\right) \right) \quad \text{(Equation D4)}$$

where:

y_1, y_2 = closest and farthest cross range distance to the populated area (see figure D-2)

σ_y = one-third of the impact dispersion radius (see figure D-2)

exp = exponential function (e^x)

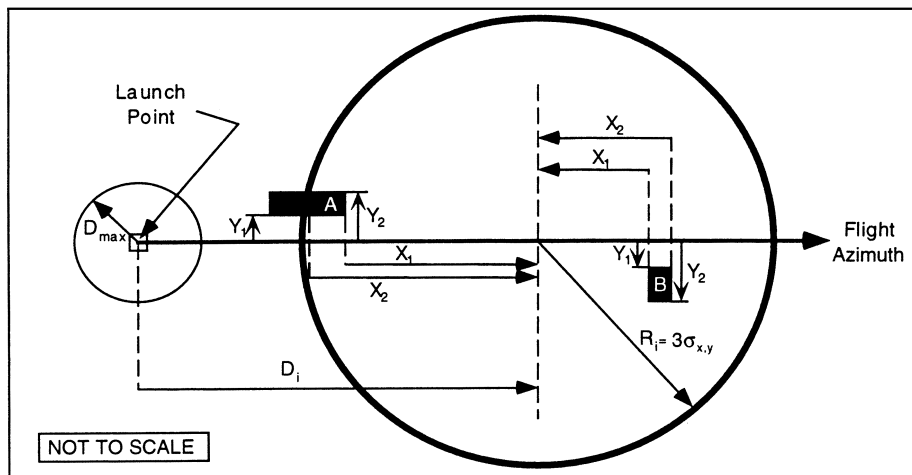

Figure D-2
Intermediate and Final Stage Impact Risk Analysis

(iii) If a populated area intersects the impact dispersion area boundary so that the x_2 or y_2 distance would otherwise extend outside the impact dispersion area, the x_2 or y_2 distance should be set equal to the impact dispersion area radius. The x_2 distance for populated area A in figure D-2 is an example.

(iv) If a populated area intersects the flight azimuth, an applicant shall solve equation D4 by obtaining the solution in two parts. An applicant shall determine, first, the prob-

ability between $y_1 = 0$ and $y_2 = a$ and, second, the probability between $y_1 = 0$ and $y_2 = b$, as depicted in figure D-3. The probability P_y is then equal to the sum of the probabilities of the two parts. If a populated area intersects the line that is normal to the flight azimuth on the impact point, an applicant shall solve equation D3 by obtaining the solution in two parts in the same manner as with the values of x .

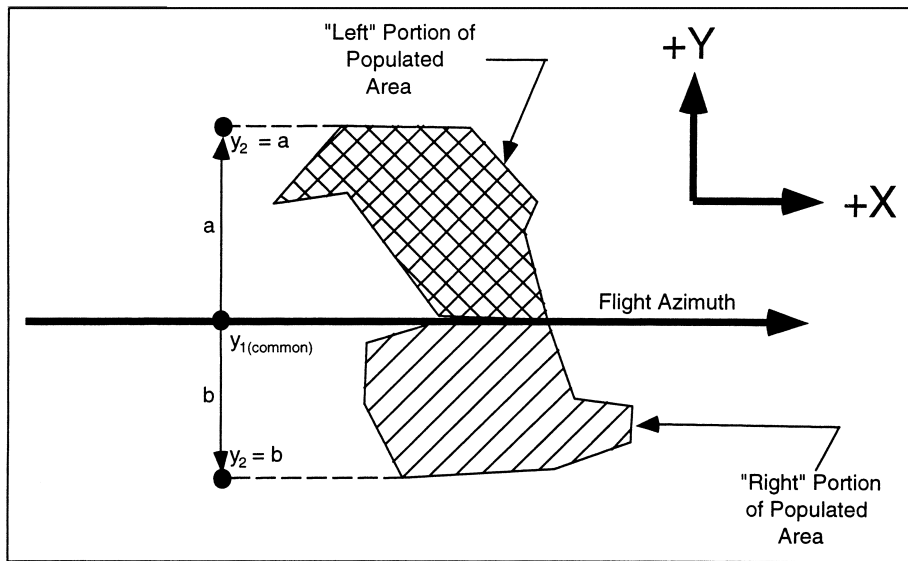

Figure D-3
Flight Azimuth Intersecting a Populated Area

(v) An applicant shall calculate the probability of impact (P_i) for each populated area using the following equation:

$$P_i = P_s \cdot P_x \cdot P_y \quad \text{(Equation D5)}$$

where:

P_s = probability of success = 0.98

(vi) An applicant shall calculate the casualty expectancy for each populated area. E_{ck} is the casualty expectancy for a given populated area as shown in equation D6, where in-

dividual populated areas are designated with the subscript "k".

$$E_{ck} = P_i \cdot \left(\frac{A_c}{A_k} \right) \cdot N_k \quad \text{(Equation D6)}$$

where:

$k \{ \{1, 2, 3, \dots, n\} \}$

A_c = casualty area (from table D-1)

A_k = populated area

N_k = population in A_k

TABLE D-1—EFFECTIVE CASUALTY AREA (A_c) VS. IMPACT RANGE

Impact range (nm)	Effective casualty area (miles ²)
0-4	9×10^{-3}
5-49	9×10^{-3}
50-1,749	1.1×10^{-5}
1,750-4,999	3.6×10^{-6}
5,000-more	3.6×10^{-6}

(vii) An applicant shall estimate the total risk using the following summation of risk:

$$E_c(\text{Corridor}) = \left(\sum_{k=1}^n E_{c_k} \right) \quad (\text{Equation D7})$$

(viii) Alternative casualty expectancy (E_c) analysis. An applicant may employ specified variations to the analysis defined by subparagraphs (d)(1)(i)–(vii). Those variations are identified in subparagraphs (viii)(A) through (F) of this paragraph. Subparagraphs (A) through (D) permit an applicant to make conservative assumptions that would lead to an overestimation of E_c compared with the analysis defined by subparagraphs (d)(1)(i)–(vii). In subparagraphs (E) and (F), an applicant that would otherwise fail the analysis prescribed by subparagraphs (d)(1)(i)–(vii) may avoid (d)(1)(i)–(vii)'s overestimation of the probability of impact in each populated area. An applicant employing a variation shall identify the variation used, show and discuss the specific assumptions made to modify the analysis defined by subparagraphs (d)(1)(i)–(vii), and demonstrate how each assumption leads to overestimation of the corridor E_c compared with the analysis defined by subparagraphs (d)(1)(i)–(vii).

(A) Assume that P_x and P_y have a value of 1.0 for all populated areas.

(B) Combine populated areas into one or more larger populated areas, and use a popu-

lation density for the combined area or areas equal to the most densely populated area.

(C) For any given populated area, assume P_x has a value of one.

(D) For any given populated area, assume P_y has a value of one.

(E) For a given populated area, divide the populated area into smaller rectangles, determine P_i for each individual rectangle, and sum the individual impact probabilities to determine P_i for the entire populated area.

(F) For a given populated area, use the ratio of the populated area to the area of the P_i rectangle used in the subparagraph (d)(1)(i)–(vii) analysis.

(2) If the estimated expected casualty does not exceed 30×10^{-6} , the FAA will approve the launch point.

(3) If the estimated expected casualty exceeds 30×10^{-6} , then an applicant may modify its proposal and then repeat the impact risk analysis in accordance with this appendix D. If no set of impact dispersion areas exist which satisfy the FAA's risk threshold, the applicant's proposed launch site will fail the launch site location review.

APPENDIX E TO PART 420—TABLES FOR EXPLOSIVE SITE PLAN

TABLE E-1—QUANTITY DISTANCE REQUIREMENTS FOR SOLID EXPLOSIVES

Quantity (lbs.) (over)	Quantity (lbs.) (not over)	Public area distance (ft.) for division 1.1	Public area distance (ft.) for division 1.3	Intraline distance (ft.) for division 1.1	Intraline distance (ft.) for division 1.3
0	1,000	1,250	75	$D = 18 W^{1/3}$	50
1,000	5,000		115		75
5,000	10,000		150		100
10,000	20,000		190		125
20,000	30,000		215		145
30,000	40,000	$D = 40 W^{1/3}$	235		155
40,000	50,000		250		165
50,000	60,000		260		175
60,000	70,000		270		185
70,000	80,000		280		190
80,000	90,000		195		195
90,000	100,000		300		200
100,000	200,000	$D=2.42 W^{0.577}$	375		250
200,000	250,000		413		275
250,000	300,000	$D = 50 W^{1/3}$	450		300
300,000	400,000		525		350
400,000	500,000		600		400
500,000	1,000,000		800		500
Greater than 1,000,000		$D = 50 W^{1/3}$	$D = 8 W^{1/3}$	$D = 5 W^{1/3}$	

"D" equals the minimum separation distance in feet.
 "W" equals the NEW of propellant.